

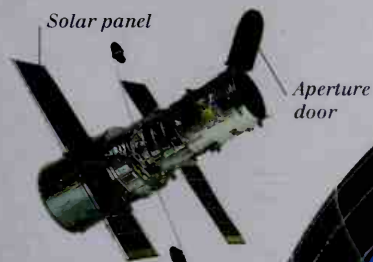

ULTIMATE VISUAL DICTIONARY OF SCIENCE

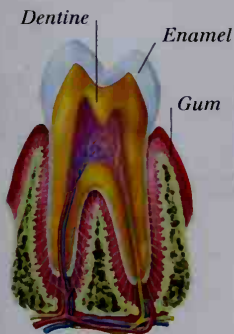

HUBBLE SPACE TELESCOPE



MOLAR TOOTH

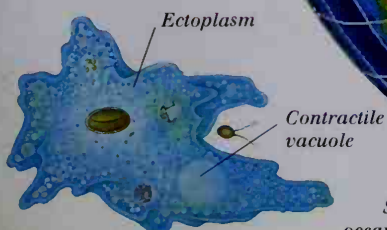

AMOEBA

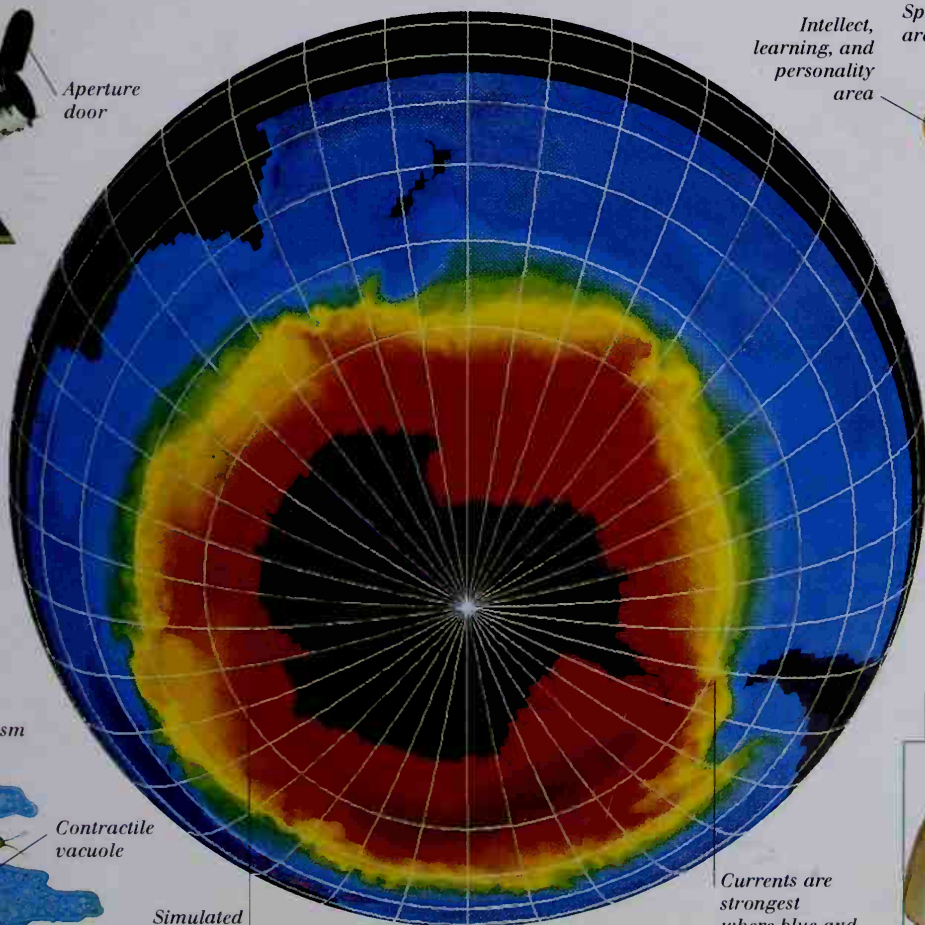

Simulated ocean currents

OCEAN CURRENTS

Currents are strongest where blue and red are close together

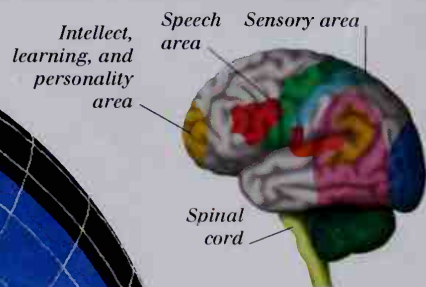

THE BRAIN

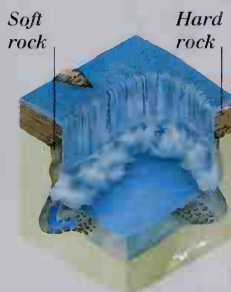

WATERFALL

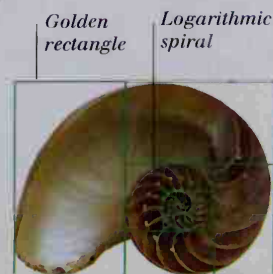

IRRATIONAL NUMBERS

DK ULTIMATE VISUAL DICTIONARY OF SCIENCE

Visually dazzling and completely accessible, the *Ultimate Visual Dictionary of Science* reveals the exciting world of science in a language far more memorable than that of traditional dictionaries. Using more than 1,600 color photographs and illustrations – each one annotated in detail – it analyzes the main scientific disciplines, including physics, chemistry, human anatomy, and astronomy, in pictures and words. Cross sections and incredible diagrams provide a unique perspective on everything from the structure of a flower to the Big Bang.

The *Ultimate Visual Dictionary of Science* covers more than 15,000 terms, with over 170 major entries and 10 different sections on everything from mathematics and computer science to life sciences and ecology. A unique source of reference for the entire family, the *Ultimate Visual Dictionary of Science* will help you discover the answers to these and thousands of other questions:

- How do bionic body parts work?
- When was the Jurassic period?
- Why is Schrödinger's cat both alive and dead?
- What is the face on Mars?

BRENTANOS PRICE

\$29.95

ULTIMATE VISUAL DICT OF SCIENC



909

\$2

DORLING K13112 Science History
5442079 CL 1 04/20/99
703-23E 000036350

DORC

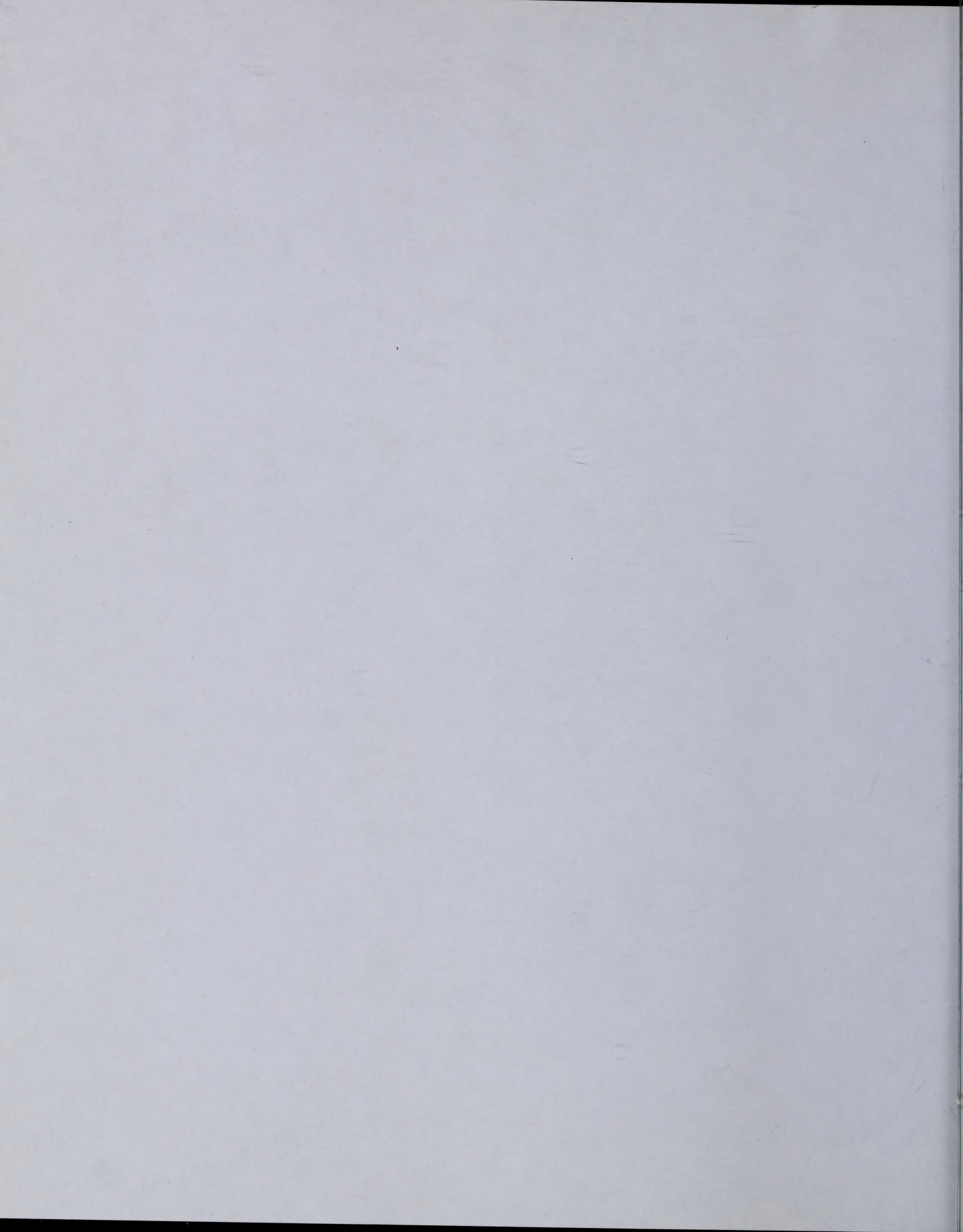

DORLING KINDERSLEY
ULTIMATE VISUAL
DICTIONARY OF
SCIENCE

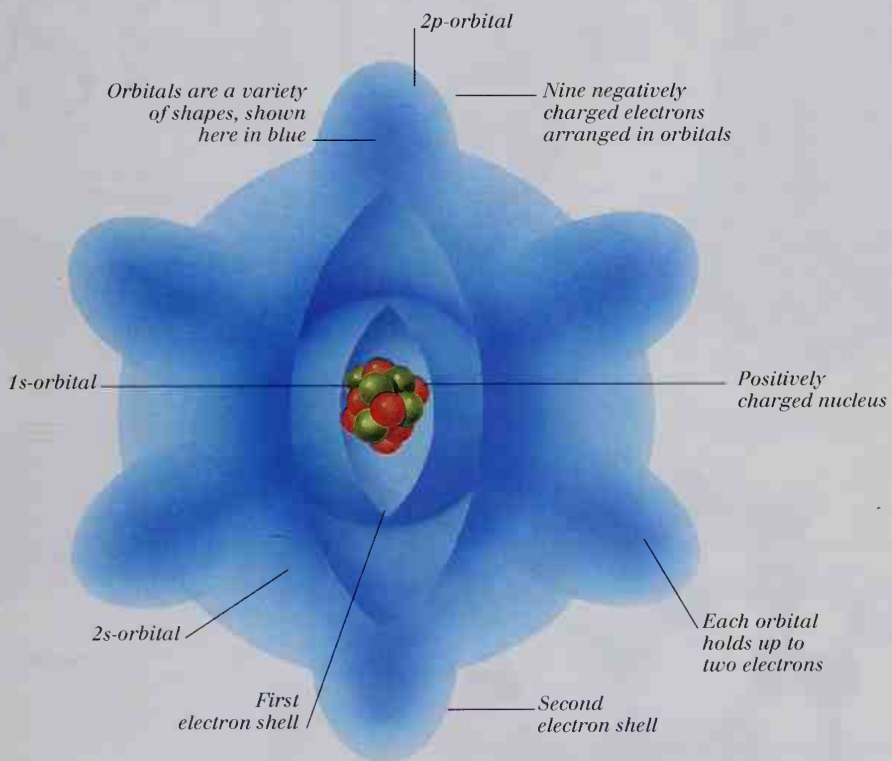

ANATOMY OF A FLUORINE ATOM

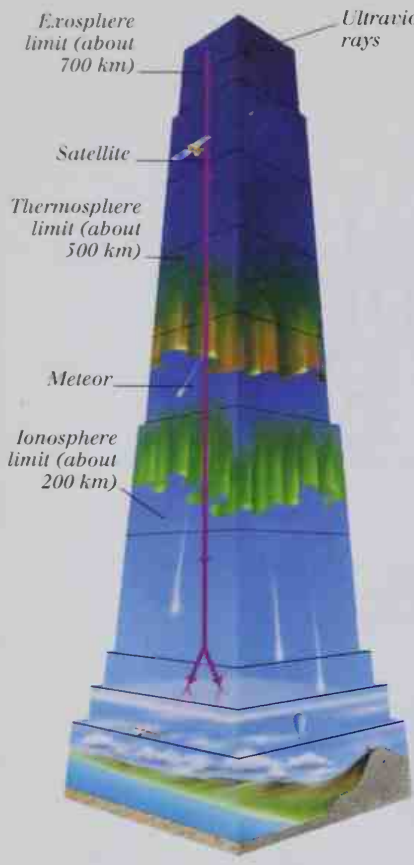

LAYERS OF THE ATMOSPHERE

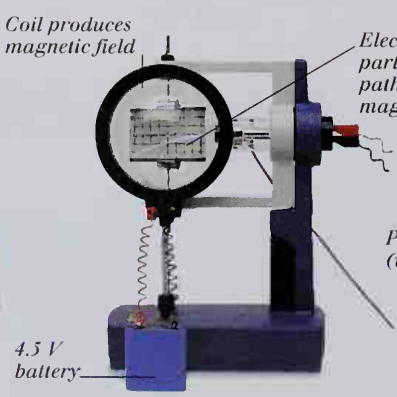

DOWNWARD DEFLECTION BY MAGNETIC FIELD

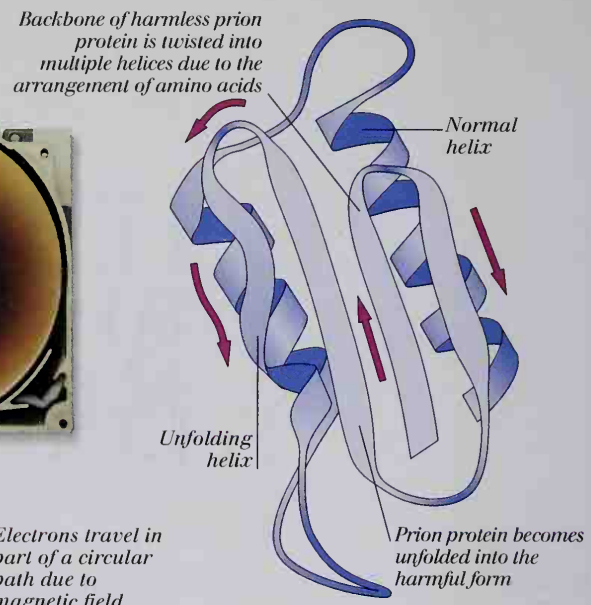

PRION PROTEIN

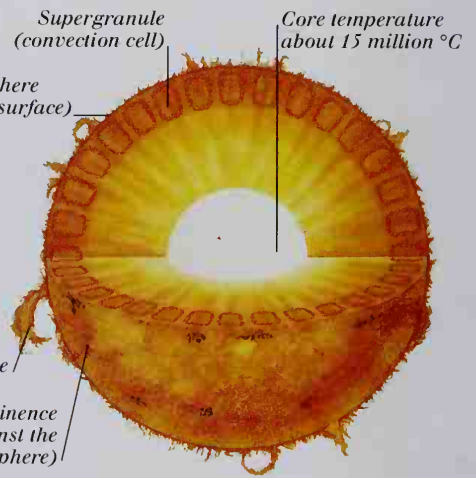

THE STRUCTURE OF THE SUN

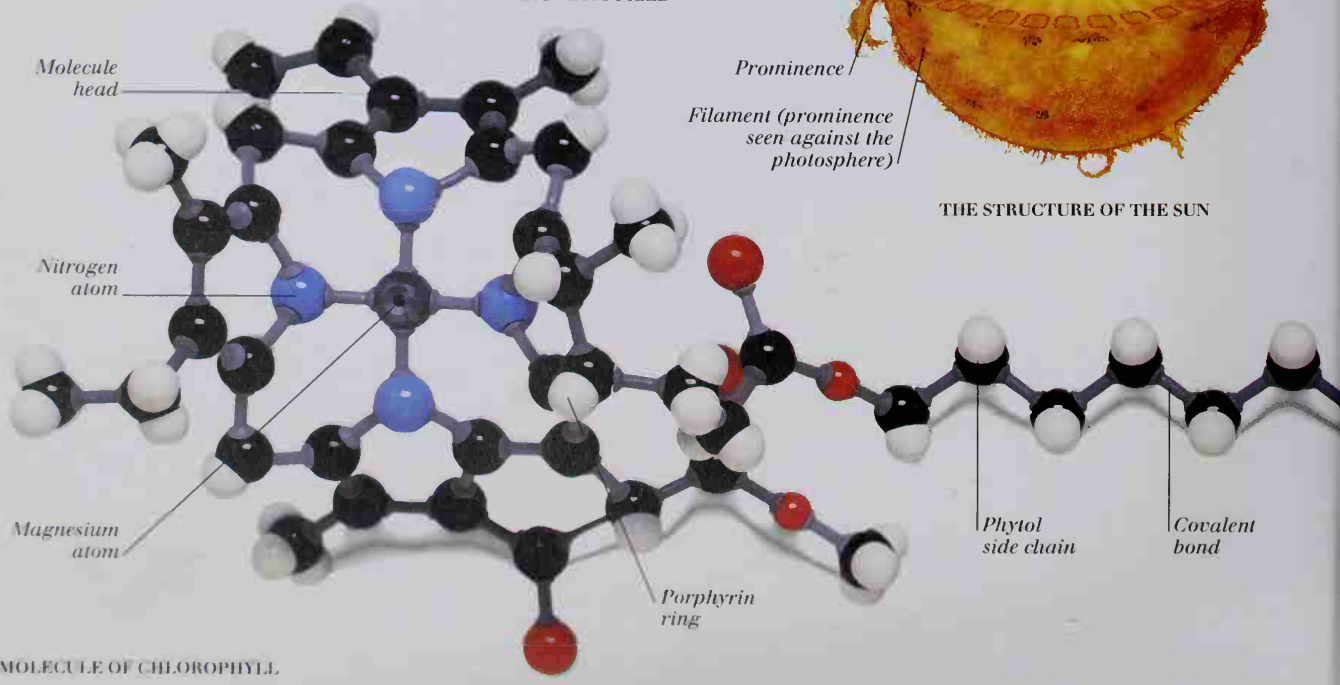

MOLECULE OF CHLOROPHYLL

DORLING KINDERSLEY
ULTIMATE VISUAL
DICTIONARY OF
SCIENCE

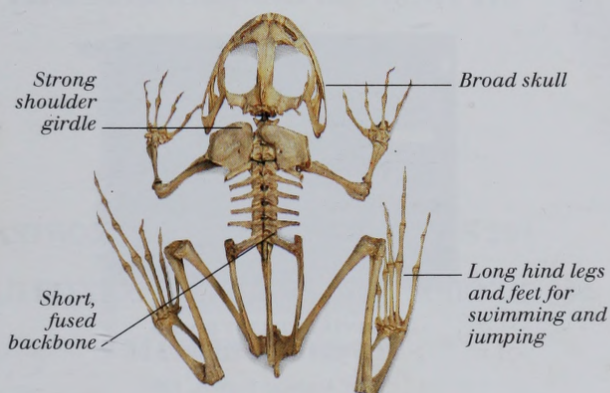

MODERN FROG

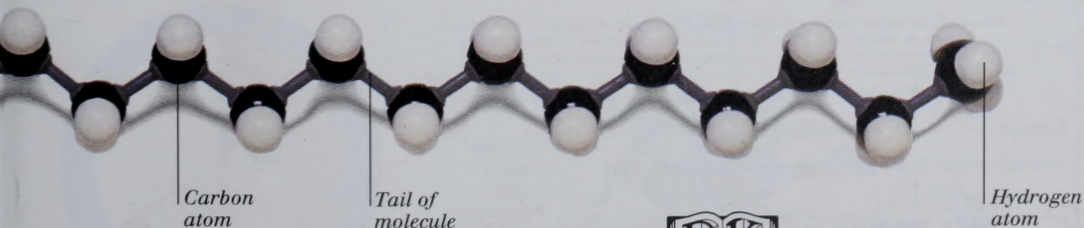

DK PUBLISHING, INC.



A DK PUBLISHING BOOK

DESIGNERS JOANNE LONG, CLAIRE NAYLOR
SENIOR ART EDITOR HEATHER MCCARRY
DEPUTY ART DIRECTOR TINA VAUGHAN

EDITOR LARA MAIKLEM
US EDITOR WILLIAM LACH
PROJECT EDITOR MIKE FYLNN
SENIOR EDITORS GEOFFREY STALKER, CHRISTINE WINTERS
SENIOR MANAGING EDITOR SEAN MOORE

SENIOR CONSULTANT EDITOR JACK CHALLONER
HUMAN ANATOMY AND LIFE SCIENCES CONSULTANT RICHARD WALKER
EARTH SCIENCES CONSULTANTS PETER DOYLE, JOHN FARNDON
MEDICAL SCIENCE CONSULTANTS STEVE PARKER, DR ROBERT M YOUNGSON

PICTURE RESEARCHERS SARAH MACKAY, MAUREEN SHEERIN

PRODUCTION MANAGER SARAH COLTMAN

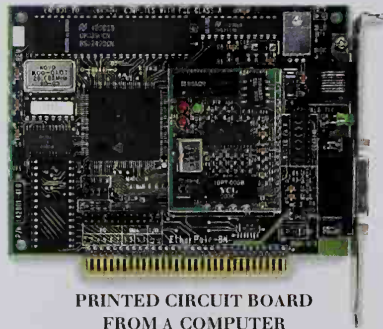

PRINTED CIRCUIT BOARD
FROM A COMPUTER

FIRST AMERICAN EDITION, 1998
2 4 6 8 10 9 7 5 3

PUBLISHED IN THE UNITED STATES BY DK PUBLISHING, INC.
95 MADISON AVENUE, NEW YORK, NEW YORK 10016

VISIT US ON THE WORLD WIDE WEB AT <http://www.dk.com>

COPYRIGHT © 1998 DORLING KINDERSLEY LIMITED, LONDON

ALL RIGHTS RESERVED UNDER INTERNATIONAL AND PAN-AMERICAN COPYRIGHT CONVENTIONS.
NO PART OF THIS PUBLICATION MAY BE REPRODUCED, STORED IN A RETRIEVAL SYSTEM,
OR TRANSMITTED IN ANY FORM OR BY ANY MEANS, ELECTRONIC, MECHANICAL, PHOTOCOPYING,
RECORDING, OR OTHERWISE, WITHOUT THE PRIOR WRITTEN PERMISSION OF THE COPYRIGHT OWNER.
PUBLISHED IN GREAT BRITAIN BY DORLING KINDERSLEY LIMITED.

LIBRARY OF CONGRESS CATALOGING-IN-PUBLICATION DATA

Ultimate visual dictionary of science. -- 1st Amer. ed.

p. cm.

Includes index
ISBN 0-7894-3512-8

1. Science--Dictionaries. 2. Picture Dictionaries, English
Q125.U43 1998
505--dc21

98-11900
CIP

REPRODUCED BY COLOURSCAN, SINGAPORE
PRINTED IN ITALY

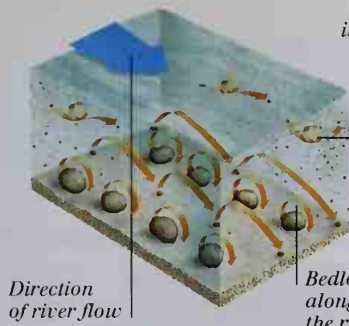

TRANSPORTATION OF LOAD

Label shows information, including blood group



BLOOD TRANSFUSION

Sterile plastic bag contains blood

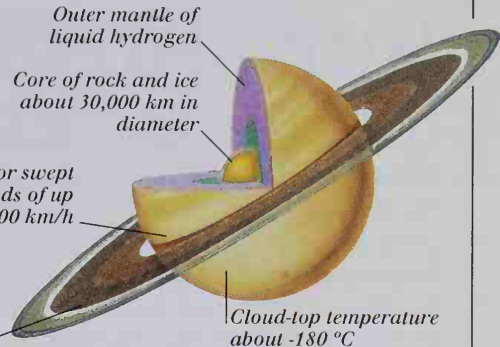

THE STRUCTURE OF SATURN

Cloud-top temperature about -180°C

CONTENTS

INTRODUCTION 6

PHYSICS 12

CHEMISTRY 64

LIFE SCIENCES AND ECOLOGY 118

HUMAN ANATOMY 176

MEDICAL SCIENCE 234

EARTH SCIENCES 264

ASTRONOMY AND ASTROPHYSICS 294

ELECTRONICS AND COMPUTER SCIENCE 334

MATHEMATICS 356

USEFUL DATA 374

BIOGRAPHIES 394

GLOSSARY 398

INDEX 414

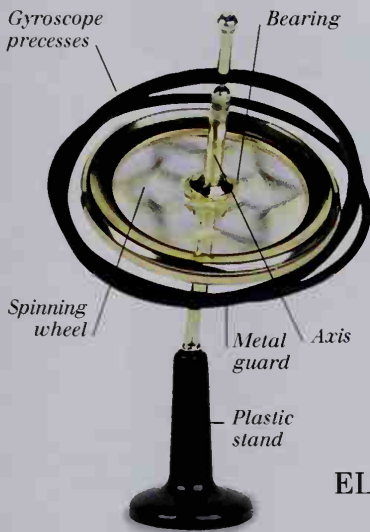

GYROSCOPE

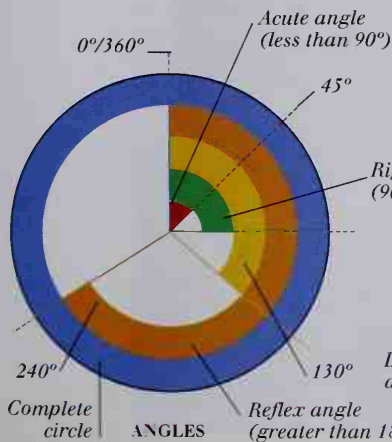

ANGLES

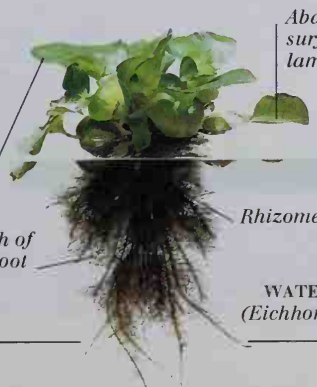

WATER HYACINTH (*Eichhornia crassipes*)

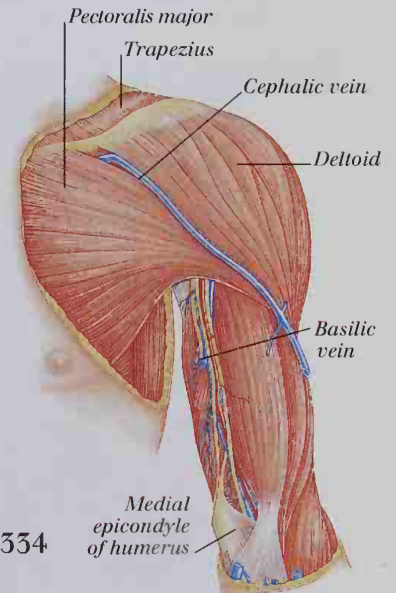

ANTERIOR VIEW OF SUPERFICIAL MUSCLES

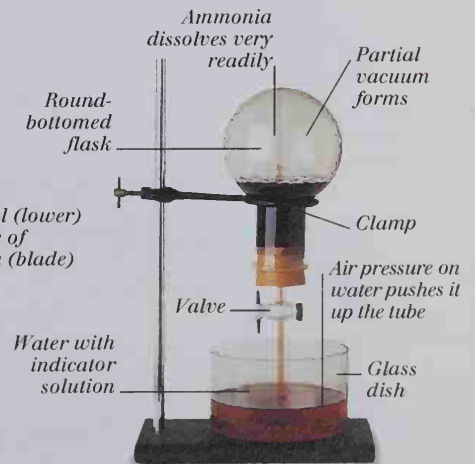

AMMONIA FOUNTAIN

Introduction

THE ULTIMATE VISUAL DICTIONARY OF SCIENCE is the definitive reference book for the major sciences. Its unique style allows you to browse the thematic sections at your leisure or to use it as a quick-reference visual dictionary. Two spreads at the beginning of the book introduce science and discuss its nature, history, and practice. The main part of the book is divided into nine themed sections, each one covering a major scientific discipline. These sections begin with a table of contents listing the key entries,

followed by a historical spread that puts the subject into its developmental context. Throughout the book you will find some words in **bold** typeface: these are words that you will find defined in the glossary. Bold words on the historical spreads are the names of important scientific figures featured in the "Biographies" (pp. 394-397). A 20-page "Useful Data" section at the back of the book contains essential scientific formulas, symbols, and charts. The book ends with a glossary and an extensive index.

Subjects featured:

Physics

Physics is perhaps the most fundamental scientific discipline. It concerns matter and energy, and its theories can be applied in every other scientific discipline, often creating a new subdiscipline such as astrophysics or medical physics.

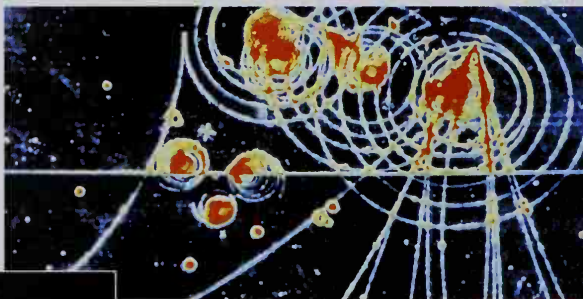

Chemistry

The science of chemistry is concerned with chemical elements, the compounds they form, and the way elements and compounds react together to make new substances. It is important in several other scientific disciplines, in particular life sciences. Biochemistry, for example, examines the compounds and reactions involved in the processes of life.

Life sciences and ecology

This section concentrates on biology, looking at the forms and functions of living organisms. It begins with consideration of the microscopic scale of cells, the building blocks of all living things, and ends with ecology, the study of how plants and animals interact with each other and their environment.



Human anatomy

Anatomy is the study of the structure of living organisms. The investigation of human anatomy and internal parts is particularly essential to medical science. This section also includes human physiology, which deals with the functions of the various systems of the human body.

Medical science

Modern science gives us a sophisticated understanding of the human body. This enables medical professionals to provide accurate and effective diagnoses and treatments, which often involves drawing on other scientific disciplines such as physics and chemistry. The medical science section of this book includes modern diagnostic techniques and emergency care.

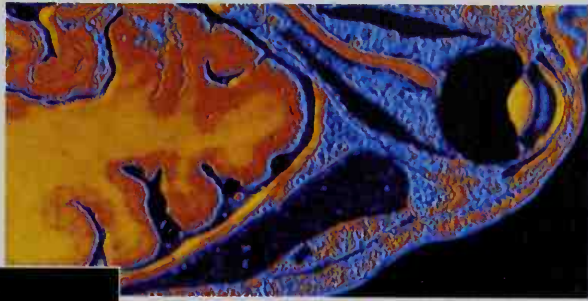

Earth sciences

The main branches of Earth sciences are geology (the study of the origin, structure, and composition of the Earth), oceanography (the study of the oceans), and meteorology (the study of the atmosphere and how it affects weather and climate).

Astronomy and astrophysics

Astronomy – the study of the universe beyond Earth's atmosphere – is the oldest science. Astrophysics is a branch of astronomy that attempts to understand the physical processes underlying the existence and behavior of planets, stars, and galaxies. Cosmology – the study of the origins and destiny of the universe – is an important part of astronomy.

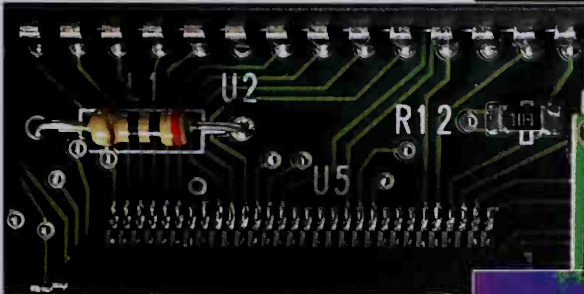

Electronics and computer science

All electronic devices are made up of simple electronic components, such as transistors, connected together to form electronic circuits. This section examines the main types of components and electronic circuits and outlines the function of the modern computer.

Mathematics

Numbers and shapes are fundamental to all sciences and to society at large. Mathematics is the science of numbers and shapes. This section of the book explains some of the key features of mathematics, including areas of modern mathematics, such as chaos theory and fractals.

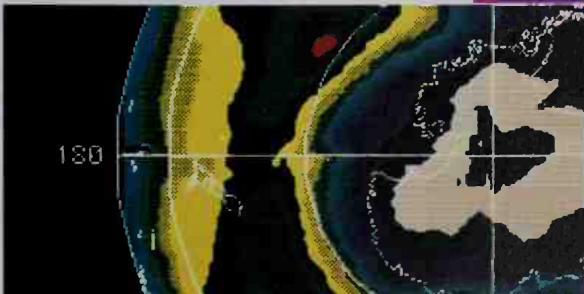
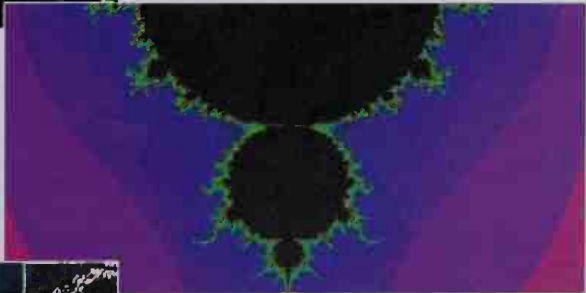

Useful data

It is essential for a science reference book to include scientific formulas, symbols, and charts. The information contained in this section reinforces and extends the information found in the main body of the book.

What is science?

THE WORD "SCIENCE" comes from the Latin *scientia*, meaning knowledge. Science is both the systematic method by which human beings attempt to discover truth about the world, and the theories that result from this method. The main "natural sciences" are physics, chemistry, life sciences (biology), earth sciences, and astronomy. All of these – except life sciences – are called physical sciences. Subjects such as anatomy and medicine – and usually ecology – are considered parts of life science. Mathematics is not strictly a natural science, because it does not deal with matter and energy directly; it examines more abstract concepts, such as numbers. However, mathematics is important because it is used to describe the behavior of matter and energy in all the sciences.

SCIENCE AND TECHNOLOGY

Scientists rely on technology to carry out their experiments.

It may be as simple as a quadrat – a rigid square thrown at random in a field in order to take a representative sample and estimate populations of plants or animals. Or it may be very complex, such as a supercomputer that applies statistics to millions of collisions taking place in particle accelerators. The relationship between science and technology works the other way, too. The design of a car's transmission, for example, requires a good understanding of the physics of simple machines. Despite this close relationship, science and technology are not the same thing. Unlike science, technology is not a quest for understanding – it is the application of understanding to a particular problem or situation. To discover the true nature of science, we need to briefly outline the history of scientific thought.

MYTHICAL WORLD VIEW

People in ancient civilizations developed stories – myths – to explain the world around them. Creation myths which attempted to explain the origin of the universe were common, for example. Most myths were probably never intended to be believed. However, in the absence of other explanations, they often were. These myths were handed down from

generation to generation as folktales, and some persist today in many cultures and religions. The roots of the scientific approach to understanding the world are generally thought to be in ancient Greece, where natural philosophers began to reject the mythical worldview and replace it with logical reasoning.

ARISTOTLE AND DEDUCTION

The ancient Greek approach to understanding natural phenomena is typified by the writings of Aristotle (384 – 322 BC). Like others of his time, Aristotle used a process known as deduction, which seeks explanations for natural phenomena by applying logical arguments. An example of this comes from Aristotle's *Physics*. It was assumed that some types of matter, such as smoke, have the quality of "lightness," while others, such as stone, have the quality of "heaviness." (The truth of why things float or sink is not as simple as this.) Applying logic to this assumption, it seemed to Aristotle that all matter naturally moves either upward or downward. He therefore claimed that any matter that neither falls nor rises upward, such as the stars and the planets, must be made of something fundamentally different from matter on Earth. The problem with this deductive process was that flawed assumptions led to incorrect conclusions. Aristotle and his contemporaries saw no need to test their assumptions, or explanations, and this is what sets the process of deduction apart from true science.

THE SCIENTIFIC REVOLUTION

The explanations given by the ancient Greek natural philosophers were adhered to across Europe and the Arab world during the Middle Ages –

PRECIPITATION
REACTION
BETWEEN LEAD
NITRATE AND
LEAD IODIDE

PRECIPITATION REACTION

The precipitation reaction between lead nitrate and lead iodide, shown here, is caused by a rearrangement of atoms and molecules. Science has proved the existence of atoms.

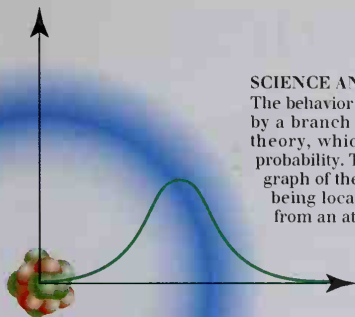

SCIENCE AND REALITY

The behavior of electrons can be predicted by a branch of physics known as quantum theory, which uses the mathematics of probability. The curve shown here is a graph of the probability of an electron being located at different distances from an atomic nucleus.

are the theory of gravitation and the theory of evolution. The more evidence in favor of a particular theory, the more strongly it is held onto. Theories can be refined or completely replaced in the light of observations that do not support them.

THE LAWS OF NATURE

A scientific law is different from a scientific theory. A law is a mathematical relationship that

describes how something behaves. (The law of conservation of mass states that no mass is lost or gained during a chemical reaction.) It is derived from painstaking measurements and other observations, and a theory may be formulated to explain the observed law. In the case of the conversion of mass, one plausible theory is that matter consists of particles that join in particular ways, and a chemical reaction is simply a change in the arrangement of the particles. Discovering the laws of nature and formulating theories to account for them can explain, in ever greater detail, only how – but not why – things happen. However, the methodical efforts of the scientific community – together with the inspirational work of many individuals – have led to a deep understanding of the natural world.

LOCATION OF AN ELECTRON AT DIFFERENT DISTANCES FROM AN ATOMIC NUCLEUS

there was little original scientific thought during this period. In Renaissance Europe in the 15th and 16th centuries, there was a reawakening of the spirit of curiosity shown by the ancient Greeks. People began to question many of the untested ideas of the ancients, because new observations of the world were at odds with them. For example, Aristotle and his contemporaries had reasoned that the Earth lies at the center of the universe. During the Renaissance, several astronomers showed that this idea was not consistent with the observed motions of the planets and the Moon and the Sun. A new idea – that the Earth is in orbit around the Sun – was put forward in 1543 by Nicolaus Copernicus (1473 - 1543). There were also several other major challenges to the accepted ideas of the time. It was a period of rapid discovery, a scientific revolution.

SCIENTIFIC METHOD

Recognizing the importance of observation – empiricism – is one of the major features of the scientific method. Another is the testing of suggested explanations by performing experiments. An experiment is an observation under carefully controlled conditions. So, for example, the hypothesis (idea) that all objects on the Earth fall at the same rate in the absence of air, can be tested by setting up suitable apparatus and observing the results. The proof of this hypothesis would support the current theory about how objects fall. A theory is a general explanation of a group of related phenomena. Examples

NATURAL LAWS

The forces acting on a weight on a slope can be measured – here they are measured using a newton meter. If this process is repeated for steeper or shallower slopes, a relationship between the force and the angle of the slope arises. A law can be formulated from this, and a theory to explain the law may follow.

MEASURING THE FORCES ACTING ON A WEIGHT ON A SLOPE WITH A NEWTON METER

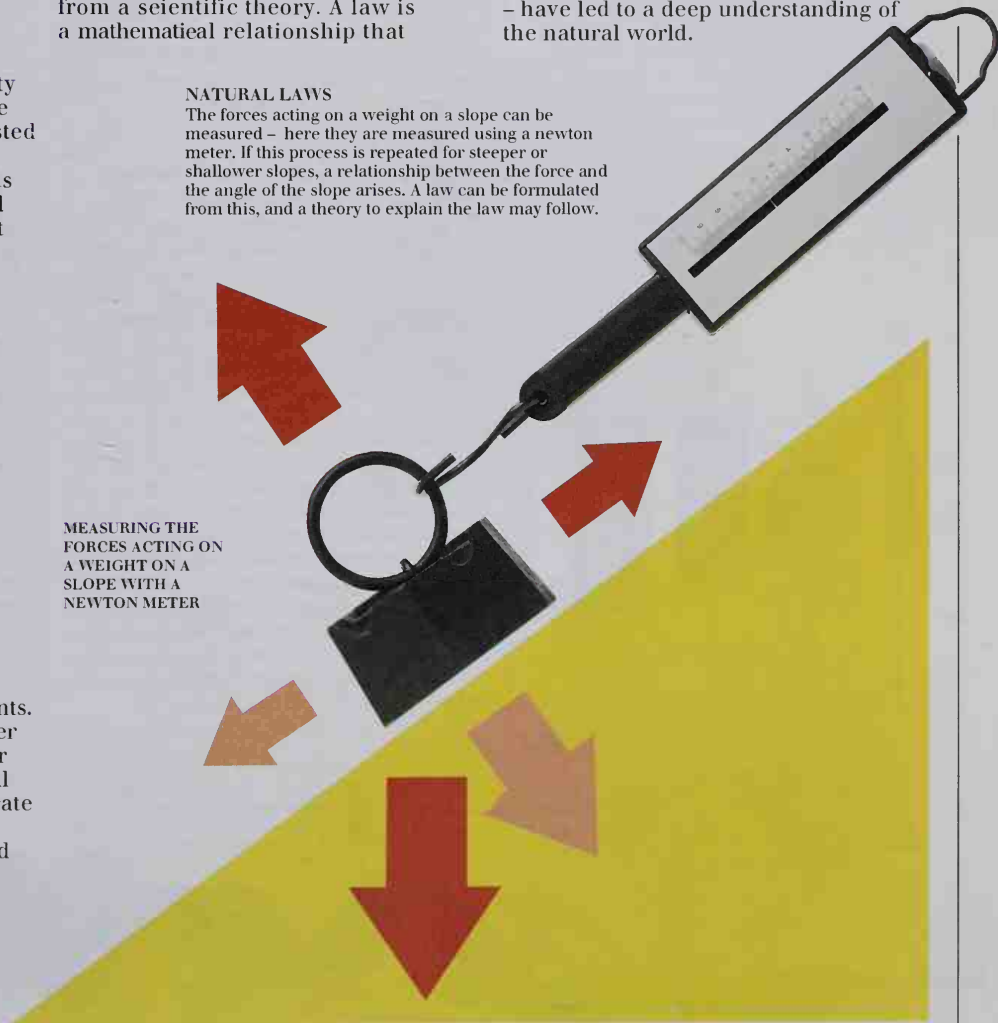

The practice of science

SINCE THE SCIENTIFIC REVOLUTION of 17th- and 18th-century Europe (see pp. 8-9), science has had an ever increasing impact on our everyday lives. The proportion of the population engaged in scientific or technological activity has increased dramatically since that time, too. The number of regularly published scientific journals in the world stood at about 10 in 1750. By 1900, there were about 10,000, and there are now over 40,000. Science is carried out by professionals as well as amateurs, and by groups as well as individuals. They all communicate their ideas between themselves, to their funding agencies, and to the world in general.

BECOMING A SCIENTIST

Scientists need to be up-to-date with the latest developments in their field of interest. For this reason, most professional scientists have a university degree and are members of professional societies. The first such societies were formed in Europe during the 17th century. Since that time, the number of people worldwide engaged in scientific activity has increased enormously. The amount and detail of scientific understanding have also increased, with the result that most scientists can be experts in only a very tiny part of their subject. Scientific

societies encourage professionalism in science and communication between scientists. There are, however, many amateur scientists whose contribution in certain fields of science is highly valuable. In astronomy, in particular, amateurs have been responsible for many important discoveries, such as finding new comets.

LABORATORIES

The word "laboratory" may conjure up images of wooden benches and countless bottles of chemicals. Some laboratories – particularly those devoted to chemistry – are indeed something like this, but are today also equipped with high-tech devices, such as infrared spectrometers, which can accurately identify a substance by analysis of the infrared radiation it emits. They are safe, clean, and efficient places. However, many laboratories are not like the popular image at all. A laboratory is defined as the place where a scientist carries out his or her experiments. So, a geologist sometimes considers his or her laboratory to be, say, a rock face. A biologist or medical researcher may have a field laboratory, with equipment installed in a tent or temporary building. Fixed laboratories are well-equipped rooms, usually in universities or industrial research buildings. For

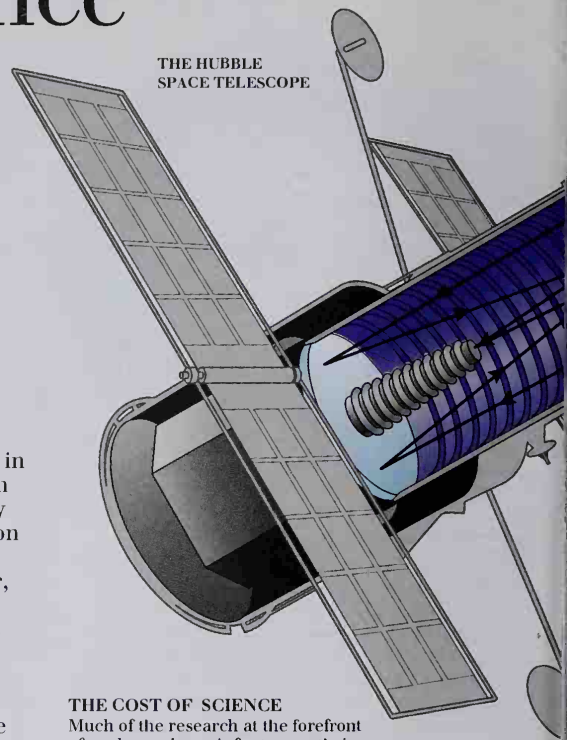

THE COST OF SCIENCE

Much of the research at the forefront of modern science is far too costly in time and money for any individual to undertake. The development of the *Hubble Space Telescope*, for example, has cost billions of dollars, and has involved thousands of scientists from many countries.

those engaged in theoretical science, their computers or even their own minds can be thought of as their laboratory.

FUNDING

Science is often expensive. A space-probe mission to Mars, for example, costs many millions of dollars, which may have to be paid by just one organization. The effort to produce a map of all human genes – known as the human genome project – is a lengthy and costly procedure that involves thousands of scientists in several different countries. There are two reasons commonly put forward to justify the huge amounts of

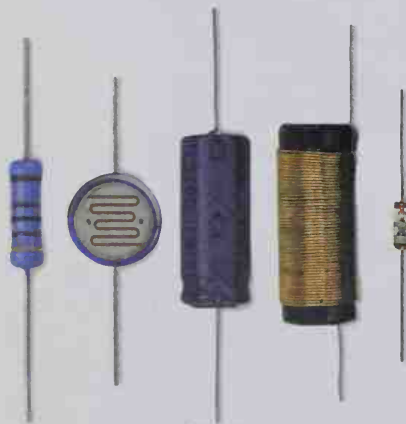

ELECTRONIC COMPONENTS

SCIENCE AND SOCIETY

Electronics is an area of scientific research that has had a huge effect on society. The subject began with the discovery of the electron in 1897. Less than a century later, the technology of electronics enabled the development of computers, television sets, and digital wristwatches, and has made possible international digital communication and trade.

WELWITSCHIA
(*Welwitschia mirabilis*)





money spent on scientific research. First, scientific progress brings technological advances. For example, without advances in medical science, diseases such as cholera would still claim millions of victims every year. The other reason often put forward to justify spending public money on science is a more philosophical one. Human beings are inquisitive creatures, and science provides answers to some fundamental questions – about our own origins, our place in space, the history of our planet, and so on. The money needed to carry out science comes from a variety of different sources. Much of the pure scientific research that goes on is government-funded and is based in universities. Some universities are partly funded by industries or wealthy individuals. Research laboratories in large companies tend to carry out applied science (technology), because most large companies are in the business of applying scientific knowledge to the development of new commercial devices or processes.

COMMUNICATING SCIENCE

There are many ways in which scientific ideas are communicated and as many methods for doing so. Scientists in the same field of research clearly need to communicate with one another to ensure that they do not duplicate on another's work and to ensure that others are aware of potentially useful findings. Scientific journals and electronic mail (e-mail) are conduits for

INTERNATIONAL SYSTEMS

The plant below is identified by all botanists as *Welwitschia mirabilis*. This binomial (two-part) classification is an internationally recognized system. Another well-known system is the SI (Système Internationale), which enables all scientists to use clearly defined standard measurements, such as the meter, in their work.



much of this communication. Researchers also need to communicate with the agencies who give grants – if those in charge of funding do not recognize the importance or quality of a piece of scientific research, they may cancel funding for it. New discoveries in one field must often be communicated clearly to scientists in different but related fields. New discoveries in organic chemistry may benefit scientists working on research in other areas, for example. The progress of science must also be communicated effectively to governments and to the public at large. Finally, accumulated scientific knowledge must be passed on from generation to generation, and so school and college education have a role to play in communicating scientific ideas.

RECOGNITION

Many scientists pursue their work for the sake of their own curiosity and passion for their subject, or because of a desire to make a useful contribution to science. They are further encouraged by the possibility of recognition in the event of a great discovery or good scientific practice. Many different prizes are awarded each year by organizations across the world. The most famous are the Nobel Prizes, first awarded in 1901. They are given out yearly in six areas of human achievement, three of which are sciences (physics, chemistry, and physiology or medicine). In some cases, scientists who have made truly great contributions become household names, such as Albert Einstein (1879 – 1955) and Isaac Newton (1642–1727).

PUBLIC UNDERSTANDING OF SCIENCE

Most people have heard of viruses, even if they do not understand how they work. A virus is shown here entering a living cell (top), reproducing (middle), and leaving the cell with its replicas (bottom). Scientific knowledge such as this can filter through to the public in school science lessons or via the media.

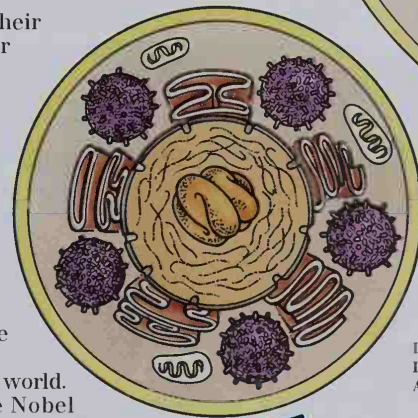
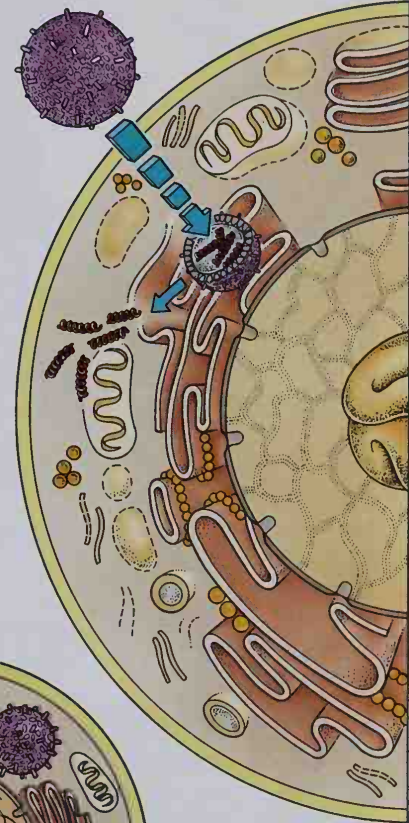

INVASION OF A LIVING CELL BY A VIRUS

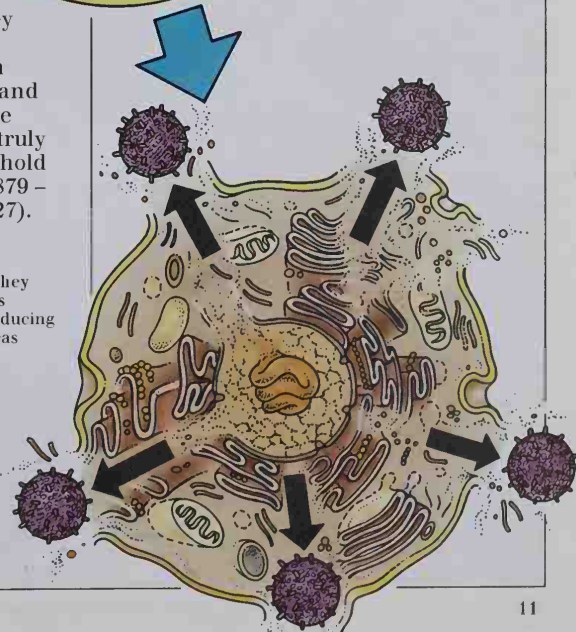



Particle tracks following the collision between two protons

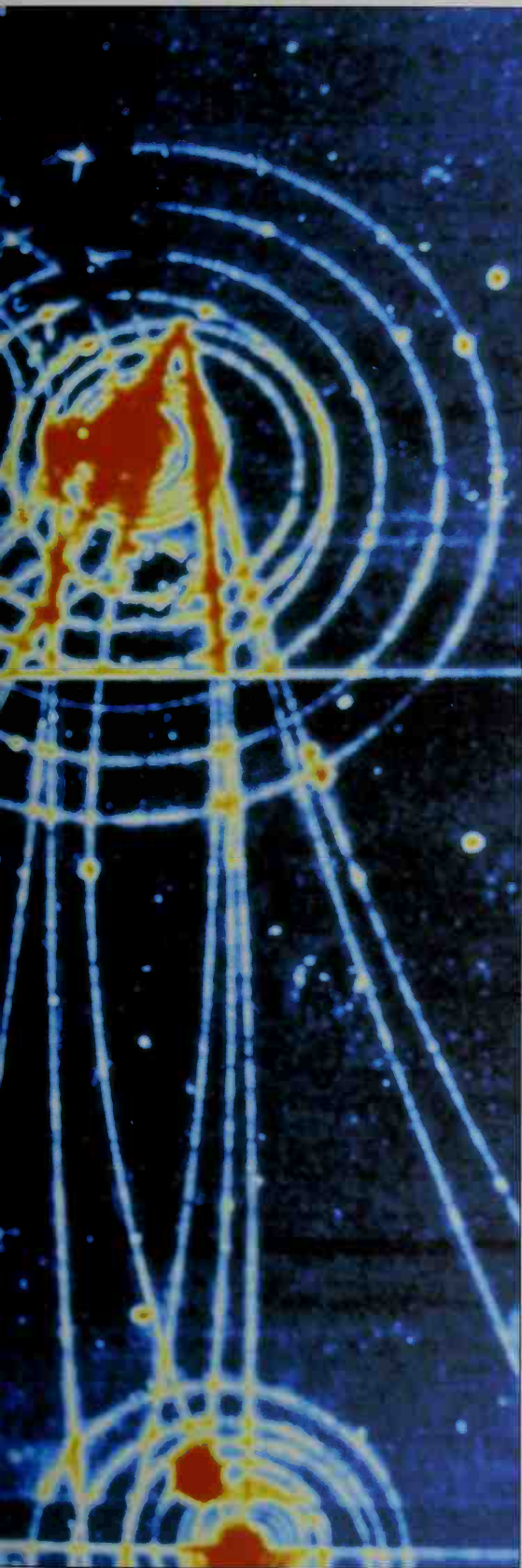

PHYSICS

DISCOVERING PHYSICS	14
MATTER AND ENERGY	16
MEASUREMENT AND EXPERIMENT	18
FORCES 1	20
FORCES 2	22
FRICTION	24
SIMPLE MACHINES	26
CIRCULAR MOTION	28
WAVES AND OSCILLATIONS	30
HEAT AND TEMPERATURE	32
SOLIDS	34
LIQUIDS.....	36
GASES	38
ELECTRICITY AND MAGNETISM	40
ELECTRIC CIRCUITS	42
ELECTROMAGNETISM	44
GENERATING ELECTRICITY	46
ELECTROMAGNETIC RADIATION	48
COLOR	50
REFLECTION AND REFRACTION	52
WAVE BEHAVIOR.....	54
ELECTRONS.....	56
NUCLEAR PHYSICS	58
PARTICLE PHYSICS	60
MODERN PHYSICS	62

Discovering physics

THE WORD “PHYSICS” derives from the Greek word for natural philosophy, *physikos*, and the early physicists were, in fact, often called natural philosophers. To a physicist, the world consists of matter and energy. Physicists spend much of their time formulating and testing theories, a process that calls for a great deal of experimentation. The study of physics encompasses the areas of force and motion, light, sound, electricity, magnetism, and the structure of matter.

ANCIENT GREECE

The study of physics is generally considered to have begun in ancient Greece, where philosophers rejected purely mythological explanations of physical phenomena and began to look for physical causes. However, Greek physics was based on reasoning, with little emphasis on experimentation. For example, early Greek philosophers reasoned that matter must be made of tiny, indivisible parts (atoms), but saw no need to establish experimental proof for the theory. Nevertheless, several areas of physics thrived in ancient Greece: mechanics (force and motion) and optics (the behavior of light) in particular. The most notable contributions to ancient Greek physics were made by Aristotle, whose ideas would influence physics for 2,000 years, despite the fact that many of them were fundamentally flawed.

MIDDLE AGES

When the first universities were founded in Europe in the 12th and 13th centuries, Greek physics was the basis of the study of the natural world. The ideas of the ancient Greeks had been preserved by Muslim academics, who had learned of them from Greek philosophers who journeyed to the East. In the universities, the ideas of Aristotle were accepted but gradually altered. For example, Aristotle's views on force and motion were developed into the “impetus” theory – an idea similar to the modern concept of momentum – in the 14th century.

RENAISSANCE

In the 15th, 16th, and 17th centuries, experimentation became the norm. Inevitably, there was conflict between those who believed the views of Aristotle, and those who accepted the new ideas arising from experimentation. The most famous example of this conflict is the story of Italian physicist Galileo Galilei. Persecuted for his ideas by the Roman Catholic Church, Galileo established new laws of motion, including proof that objects accelerate as they fall. The French

philosopher René Descartes helped to place physics on a new track by concentrating on the idea that all natural phenomena could be explained by considering particles of matter in motion. This was called the “mechanical” or “mechanistic” philosophy, and it enabled physicists to develop new theories.

NEWTONIAN PHYSICS

Isaac Newton made huge contributions to mechanics, optics, and gravitation, as well as to mathematics. In particular, his ideas about motion developed the mechanistic philosophy into a precise framework, called Newtonian physics. This view held that all of the phenomena of the Universe could be explained by particles and forces and was summarized by Newton's own Laws of Motion. Newton's theory of gravitation made an undeniable link between the motion of falling objects on the Earth and the motions of planets around the Sun. In optics, Newton identified white light as consisting of a spectrum of colors, and he investigated the effects of interference. He also explained many optical effects in terms of light behaving as particles, a view challenged by many physicists, who believed that light was the result of a wave motion. Experiments during the 18th century put the wave theory of light onto a firm footing.

NATURAL FORCES

Whether particles or waves, light was seen as one of a set of separate “natural forces.” Others included heat, electricity, and magnetism. During the 18th and 19th centuries, progress was made toward realizing the links between these forces, which were seen as “imponderable fluids” that flowed between substances. Temperature, for example, was seen as the concentration of particles of “heat fluid,” called “caloric.” The modern interpretation of heat, as the random motion of particles, was not widely believed until later, when it was realized that friction could generate endless amounts of heat. This could not be explained by the idea that heat is a fluid contained within an object. As the connection between

GALILEO'S CLOCK

The Italian scientist Galileo Galilei noticed that, although the distance a pendulum swings may vary, the time taken for each swing remains constant. He exploited this idea in his design for a pendulum clock. The clock shown here was built in 1855, based on Galileo's drawings.

motion and heat was established, so other natural phenomena were linked, in particular electricity and magnetism. In 1820, **Hans Christian Oersted** showed that an electric current produces magnetism. Electromagnetism was studied by many experimenters, in particular Michael Faraday.

ENERGY AND ELECTRO-MAGNETIC RADIATION

In the 1840s, **James Joule** established the “mechanical equivalent of heat”: the amount of heat generated by a particular amount of mechanical work. The conversion was always consistent, and a similar result when producing heat from electric current led to the definition of energy. It was soon realized that light, heat, sound, electricity, magnetism, and motion all possessed energy, and that energy could be transferred from object to object, but neither created nor destroyed. This “unified” view of the world was further established in the 1860s, when **James Clerk Maxwell** proved that light was related to electricity and magnetism. The idea led to the discovery of other forms of electromagnetic radiation: radio waves (1888), X rays (1896), and gamma rays (named in 1903). Also around this time came the first evidence of an inner structure to the atom. The electron was discovered in 1897, and in 1899 its mass was found to be less than that of an atom. New models of the atom arose, in line with quantum physics, which, along with relativity, would reshape forever the physicist’s view of the world.

MODERN PHYSICS

Albert Einstein developed his theories of relativity to make sense of space and time. Newtonian physics relied on the assumptions that space and time were absolute, assumptions that



FARADAY'S RING
Michael Faraday explored the relationship between electricity and magnetism, producing the world's first transformer.

work very well in most situations. But Newtonian physics was only an approximation to any real explanation. Einstein's relativity showed that time and space could not be absolute. This demanded a completely new outlook on the laws of physics. Einstein was also involved in the development of quantum physics, which studies the world of very small particles and very small amounts of energy. Quantum physics challenged the wave theory of light and led to the conclusion that light and other forms of electromagnetic radiation act as both particles and waves. It enabled the structure and behavior of atoms, light, and electrons to be understood and also predicted their behavior with incredible accuracy.

GRAND UNIFIED THEORY

In the 1920s, showers of subatomic particles – produced by cosmic rays that enter the atmosphere – were detected using airborne photographic plates. This led to the study of particle physics, using huge particle accelerators. In the middle of the 20th century, forces began to be understood in terms of the exchange of subatomic particles and were unified into just four fundamental interactions: gravitation, electromagnetism, the strong nuclear force, and the weak interaction.

The “holy grail” of physics is a grand unified theory (GUT) that would unify all the four forces as one “superforce” and describe and explain all the laws of nature.

NEUTRON DETECTOR

Inside this apparatus, particles from a radioactive source struck a beryllium target. Neutrons were given off but could be detected only when they “knocked” protons from a piece of paraffin wax. The protons were then detected with a Geiger counter.

TIMELINE OF DISCOVERIES

	400 BC	Democritus concludes that matter consists of indivisible particles
Flotation principle discovered by Archimedes, who also studies principles of levers	260 BC	
Galileo Galilei finds the science of mechanics	1600	William Gilbert claims that the core of the Earth is a giant magnet
Isaac Newton publishes <i>Mathematical Principles</i> , in which he formulates the laws of motion and gravitation	1658	
Battery invented by Alessandro Volta	1645	Air pressure discovered and measured by Evangelista Torricelli
Atomic theory of matter proposed by John Dalton	1665	
Electromagnetic rotation, discovered by Michael Faraday	1701	Joseph Sauveur suggests term “acoustics” for science of sound
Relationship between heat, power, and work formulated by James Joule	1799	
Dmitri Mendeleev devises the periodic table, which classifies elements into groups by atomic weight	1800	Infrared waves discovered by William Herschel
X rays discovered by Wilhelm Röntgen	1803	
Quantum theory proposed by Max Planck	1819	Hans Christian Oersted discovers electromagnetism
Atomic nucleus discovered by physicist Ernest Rutherford	1821	
Albert Einstein publishes his general theory of relativity	1851	Electromagnetic induction discovered by Michael Faraday
First particle accelerator built by John Cockcroft and Ernest Walton	1843	
First nuclear reactor built by Enrico Fermi	1846	Laws of thermodynamics developed by William Kelvin
Chaos theory developed by American mathematicians	1869	
	1888	Existence of radio waves demonstrated by Heinrich Hertz
	1896	
	1897	Electron discovered by Joseph Thomson
	1900	
	1905	Albert Einstein publishes his special theory of relativity
	1911	
	1915	Electron shells around nucleus of atom proposed by Niels Bohr
	1915	Albert Einstein publishes his general theory of relativity
	1919	Ernest Rutherford converts nitrogen nuclei into oxygen nuclei
	1932	
	1938	Nuclear fission discovered by Otto Hahn and Fritz Strassmann
	1942	
	1964	Existence of quarks proposed by Murray Gell-Mann
	1980s	
	1986	Superconductors, substances with extremely low resistances to electricity, are developed



Matter and energy

PHYSICS IS THE STUDY OF MATTER AND ENERGY. Matter is anything that occupies space. All matter consists of countless tiny particles, called **atoms** (see pp. 72-73) and **molecules**. These particles are in constant motion, a fact that explains a phenomenon known as **Brownian motion**. The existence of these particles also explains **evaporation** and the formation of **crystals** (see pp. 34-35). Energy is not matter, but it affects the behavior of matter. Everything that happens requires energy, and energy comes in many forms, such as heat, light, electrical, and potential energy. The standard unit for measuring energy is the joule (J). Each form of energy can change into other forms. For example, electrical energy used to make an electric motor turn becomes **kinetic energy** and heat energy (see pp. 32-33). The total amount of energy never changes; it can only be transferred from one form to another, not created or destroyed. This is known as the **Principle of the Conservation of Energy**, and can be illustrated using a **Sankey Diagram** (see opposite).

PARTICLES IN MOTION

BROWNIAN MOTION

When observed through a microscope, smoke particles are seen to move about randomly. This motion is caused by the air molecules around the smoke particles.

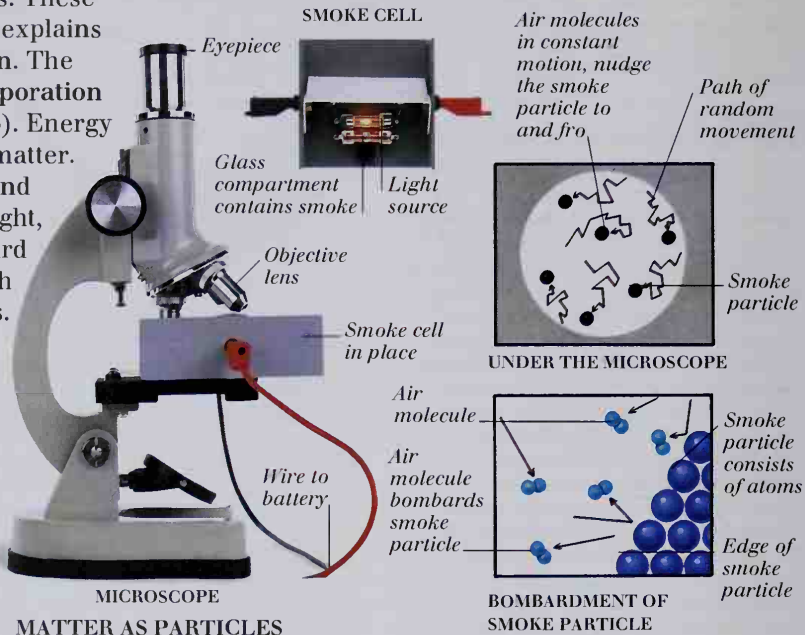

DISSOLVING



Glass beaker
Solid dissolves to form a solution
Water
Solid potassium permanganate

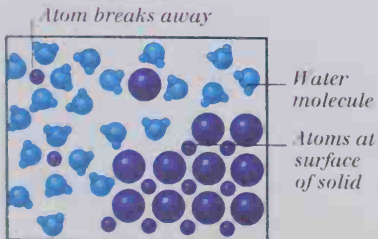

DISSOLVING
The particles of a solid are held together in a rigid structure. When a solid dissolves into a liquid, its particles break away from this structure and mix evenly in the liquid, forming a **solution**.

EVAPORATION

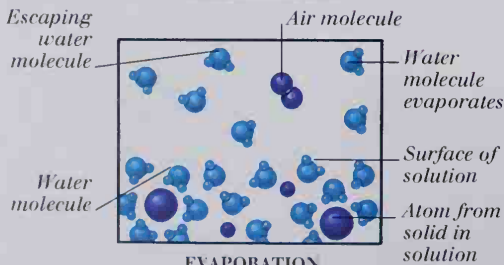

EVAPORATION
When they are heated, most liquids evaporate. This means that the atoms or molecules of which they are made break free from the body of the liquid to become gas particles.

CRYSTALLIZATION

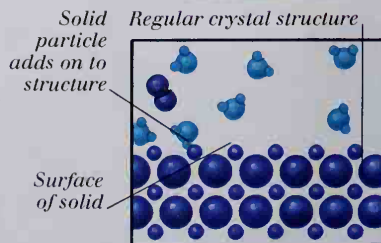
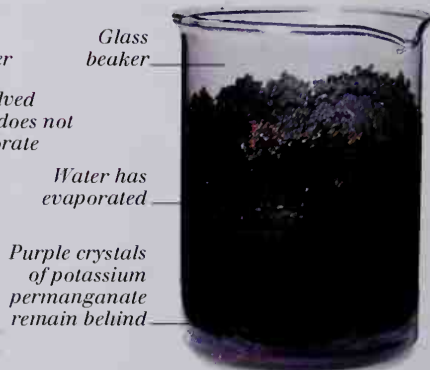

CRYSTALLIZATION
When all of the liquid in a solution has evaporated, the solid is left behind. The particles of the solid normally arrange in a regular structure, called a **crystal**.



THE CONSERVATION OF ENERGY

Sun
Energy radiates into space

Radiation is made in the Sun's core during nuclear reactions and is the source of most of the Earth's energy

PHOTOVOLTAIC CELL

A transfer of energy, from electromagnetic radiation to electrical energy, takes place in a photovoltaic cell, or solar cell. When no sunlight falls on it, it can supply no electricity.

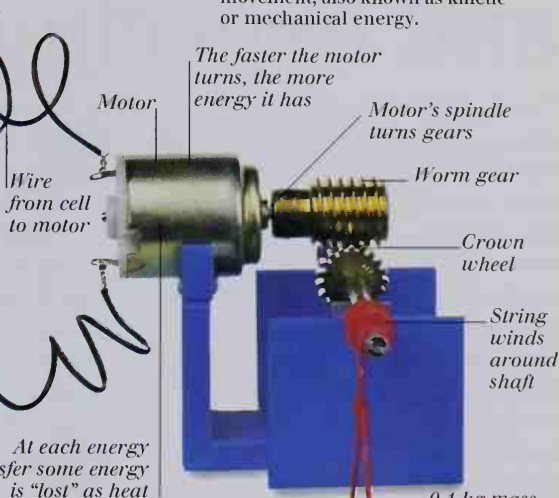
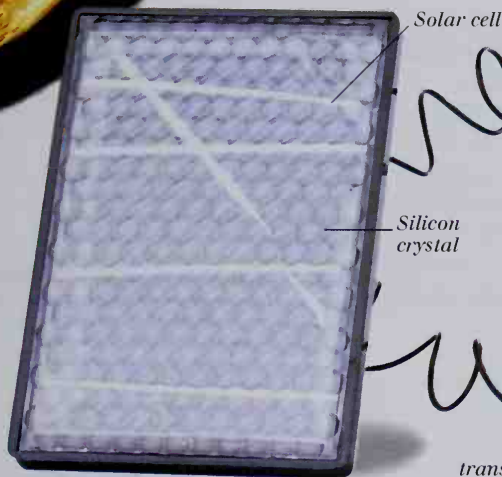

ELECTRIC MOTOR
Inside an electric motor, electrical energy becomes the energy of movement, also known as kinetic or mechanical energy.

The faster the motor turns, the more energy it has

ENERGY TRANSFER

SANKEY DIAGRAM

This Sankey diagram shows the energy transfers in an electric motor.

Width of the arrow here shows how much energy is available

0.31 J of electrical energy supplied each second

0.21 J wasted as heat in the motor

0.1 J of kinetic energy

Arrowhead shows where energy is transferred

POTENTIAL ENERGY

As the motor turns, it winds a string around a shaft via a set of gears.

The string lifts a 0.1 kilogram mass against gravity. The kinetic energy transfers to potential, or stored energy. If the string is broken, the energy will be released, and the mass will fall, gaining kinetic energy.

0.1 kg mass lifted to 1 m

Mass has potential energy of 1 J
String lifts 0.1 kg mass

ENERGY TRANSFERS IN A CAR

A car's energy comes from burning gasoline in the engine. This includes the electrical energy in its battery, the potential energy stored as it climbs a hill, and any heat generated in the brakes or the engine. The arrows show energy transfer.

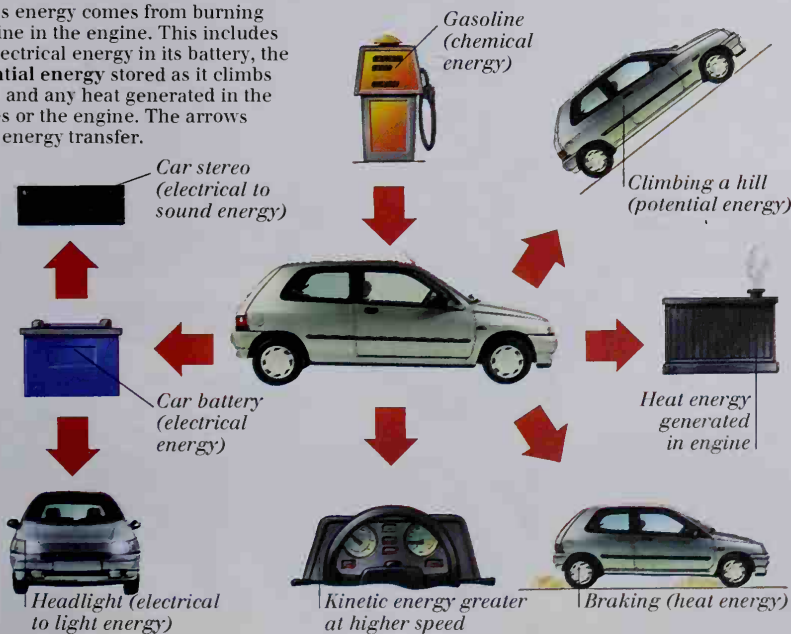

1 kg mass lifted to 0.9 m

Mass has potential energy of 0.9 J

0.1 kg mass lifted to 0.8 m

Mass has potential energy of 0.8 J

0.1 kg mass

Measurement and experiment

THE SCIENCE OF PHYSICS IS BASED on the formulation and testing of theories. Experiments are designed to test theories and involve making measurements – of mass, length, time, or other quantities. In order to compare the results of various experiments, it is important that there are agreed standard units. The kilogram (kg), the meter (m), and the second (s) are the fundamental units of a system called **SI units** (Système International). Physicists use a variety of instruments for making measurements. Some, like the Vernier callipers, traveling microscopes, and thermometers, are common to many laboratories, while others will be made for a particular experiment. The results of measurements are interpreted in many ways, but most often as graphs. Graphs provide a way of illustrating the relationship between two measurements involved in an experiment. For example, in an experiment to investigate falling objects, a graph can show the relationship between the duration and the height of the fall.

MASS AND WEIGHT

Mass is the amount of matter in an object, and is measured in kilograms. Gravitational force gives the mass its weight. Weight is a force, and is measured in newtons (see pp.10-11), using a newton meter like the one shown on the right. It is common to speak of weight being measured in kilograms, but in physics this is not correct.

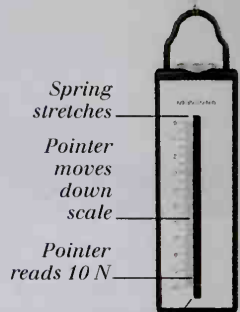

Spring in meter produces force to balance weight

1 kg mass

Powder to be weighed

NEWTON METER AND KILOGRAM MASS

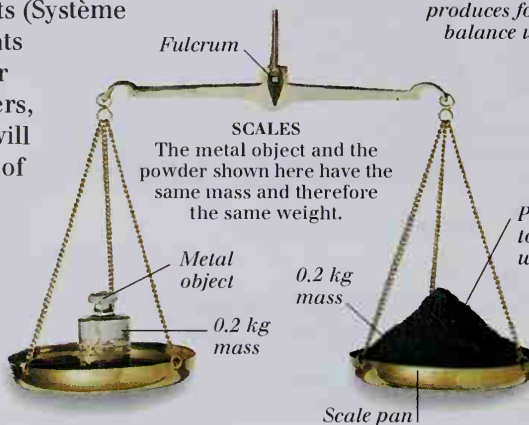

Fulcrum

SCALES

The metal object and the powder shown here have the same mass and therefore the same weight.

Metal object

0.2 kg mass

0.2 kg mass

Scale pan

MEASURING DISTANCE

Adjustable eyepiece

Eyepiece contains fine crossed wires

TRAVELING MICROSCOPE

A Vernier scale makes the traveling microscope an accurate instrument for measuring small distances across objects. Two readings are taken and the difference between the positions of the microscope on its sliding scale provides the measurement.

Focusing knob

Vernier scale

Ordinary scale

Diecast body

Turning knob moves microscope along rails

Microscope body

Microscope slides on rails

Objective lens

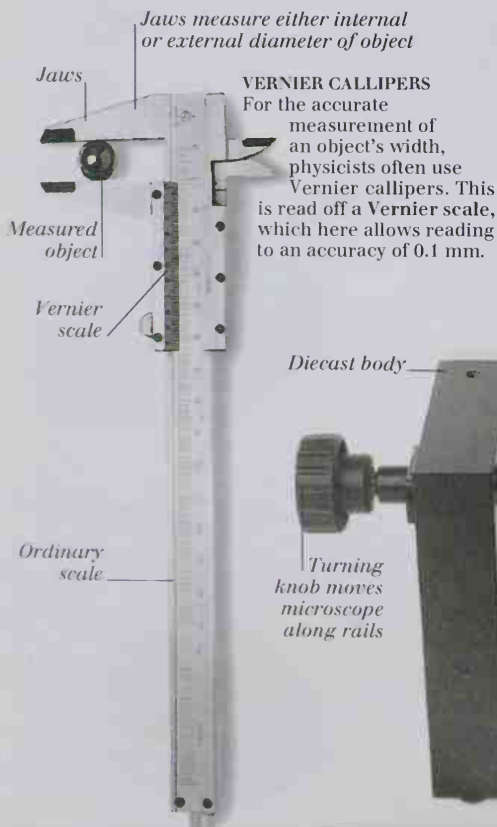

VERNIER CALLIPERS

For the accurate measurement of an object's width, physicists often use Vernier callipers. This is read off a Vernier scale, which here allows reading to an accuracy of 0.1 mm.

THERMOMETERS

There are two types of thermometers commonly used in modern physics. The mercury thermometer has a glass bulb containing mercury that expands as the temperature rises, while the digital thermometer contains an electronic probe and has a digital readout.

DIGITAL THERMOMETER

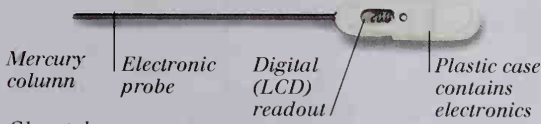

MERCURY THERMOMETER

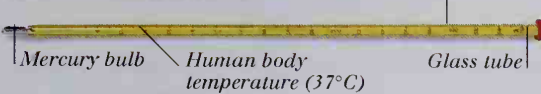

MAGNIFIED VIEW OF MERCURY THERMOMETER

Glass bulb

INTERPRETING DATA

TABLE OF RESULTS FOR A FREEFALL EXPERIMENT

A steel ball is dropped from a variety of heights and the duration of each fall is timed. The results of these measurements are entered into a table.

HEIGHT (m)	0	0.05	0.10	0.15	0.20	0.25	0.30	0.35	0.40	0.45	0.50
TIME (s)	0	0.10	0.14	0.17	0.21	0.22	0.24	0.26	0.27	0.30	0.31

RESULTS OF A FREEFALL EXPERIMENT IN GRAPH FORM

A graph allows us to visually identify the relationship between the time and the height of the fall. There is an element of uncertainty or error in every result obtained, so each is plotted on the graph as a short range of values forming an error bar instead of a point. The curve is drawn so that it passes through all the bars.

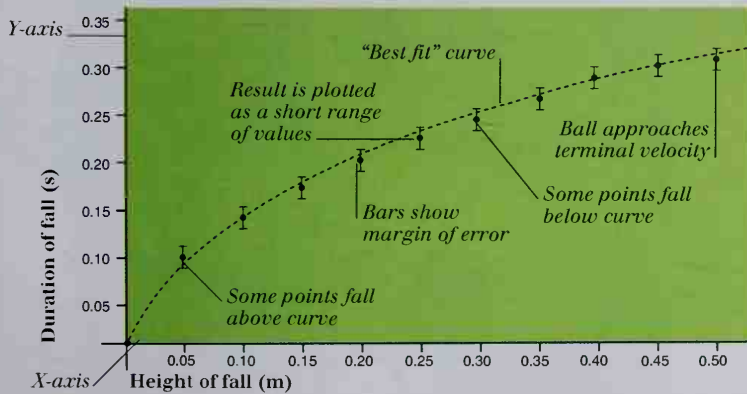

FREEFALL EXPERIMENT

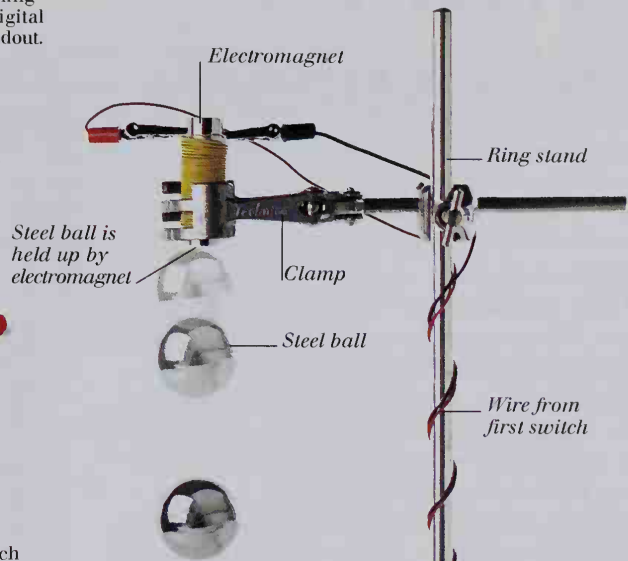

Wire from first switch

Ball accelerates due to the pull of gravity

APPARATUS FOR TIMING THE FALL OF AN OBJECT
A switch turns off the electromagnet, releasing the ball while simultaneously starting the timer. As the ball hits the ring stand base, a second switch is activated, and the timer stops. Times of falls from various heights are measured and plotted on a graph (see left).

As ball hits base, second switch is activated

Switch (two contacts normally held apart)

Ring stand base

Wire to battery

Electronic timer

Electronic timer stand

Digital display

Wire from second switch

Wire from first switch

Switch

Clip

Forces 1

A FORCE IS A PUSH OR PULL, and can be large or small. The usual unit of force is the newton (N), and can be measured using a **newton meter** (see pp. 18-19). Force can be applied to objects at a distance or by making contact. **Gravity** (see pp. 22-23) and **electromagnetism** (see pp. 44-45) are examples of forces that can act at a distance. When more than one force acts on an object, the combined force is called the **resultant**. The resultant of several forces depends on their size and direction. The object is in **equilibrium** if the forces on an object are balanced with no overall resultant. An object on a solid flat surface will be in equilibrium, because the surface produces a reaction force to balance the object's weight. If the surface slopes, the object's weight is no longer completely canceled by the reaction force and part of the weight, called a **component**, remains, pulling the object toward the bottom of the slope. Forces can cause rotation as well as straight line motion. If an object is free to rotate about a certain point, then a force can have a turning effect, known as a **moment**.

RESULTANT FORCE

A 1 kg mass has a weight of 10 N. Here, this weight is supported by two lengths of wire. Each wire carries a force that pulls against the other at an angle. The combination or resultant of these forces is 10 N vertically upward and exactly balances the weight. The force carried by each wire is measured by newton meters.



THE METER READINGS
Between them, the two wires support a weight of 10 N, so why is the reading on each newton meter more than 5 N? As well as pulling upward, the wires are pulling sideways against each other, so the overall force showing on each meter is 5.8 N.

REACTION FORCES

FORCES ON A LEVEL SURFACE

A table provides a force called a reaction, which exactly balances the weight of an object placed upon it. The resultant force is zero, so the object does not fall through the table.

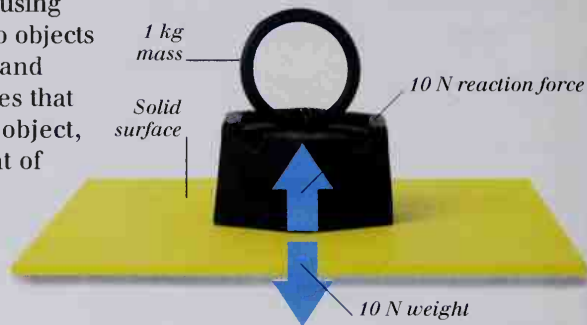

FORCES ON A SHALLOW SLOPE

Gravity acts downward on the 1 kg mass shown. The slope provides a reaction force that acts upward, perpendicular to the slope and counteracts some of the weight. All that remains of the weight is a force acting down the slope.

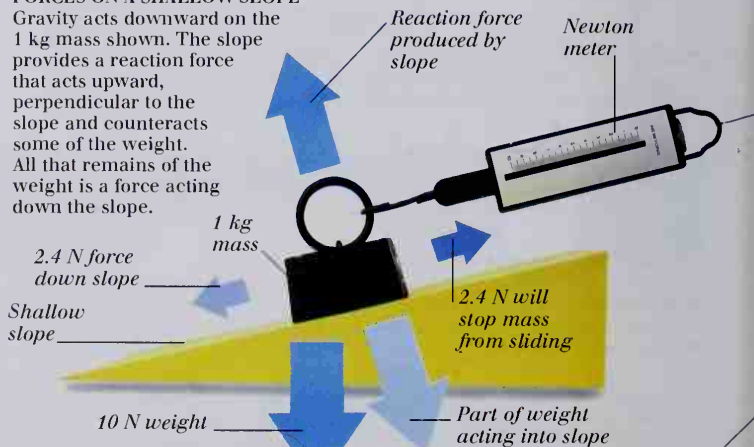

FORCES ON A STEEP SLOPE

As the slope is made steeper, the reaction force of the slope decreases, and the force pulling the mass down the slope - which is measured by the newton meter - increases. This force can pull objects downhill.

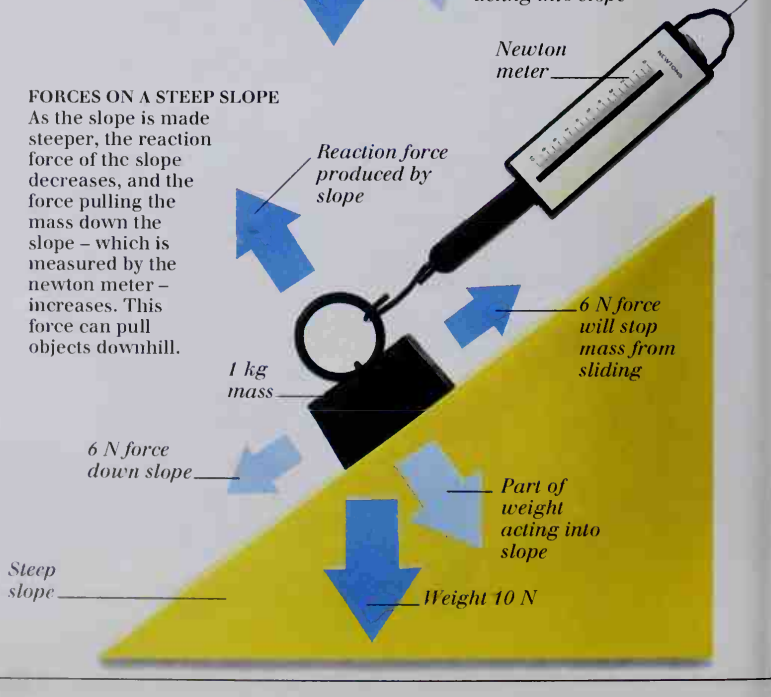

TURNING FORCES

TURNING FORCES AROUND A PIVOT

A force acting on an object that is free to rotate will have a turning effect, or turning force, also known as a moment. The moment of a force is equal to the size of the force multiplied by the distance of the force from the turning point around which it acts (see p. 378). It is measured in newton meters (Nm) or joules (J). The mass below exerts a weight of 10 N downward on a pivoted beam. The newton meter – twice as far from the pivot – measures 5 N, the upward force needed to stop the beam turning. The clockwise moment created by the weight and counterclockwise moment created by the upward pull on the newton meter are equal, and the object is therefore in equilibrium.

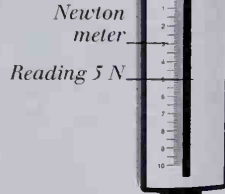

The weight of the beam above is spread along its length. The moments are balanced if the object is suspended at its center of gravity.

OBJECT SUSPENDED AWAY FROM CENTER OF GRAVITY

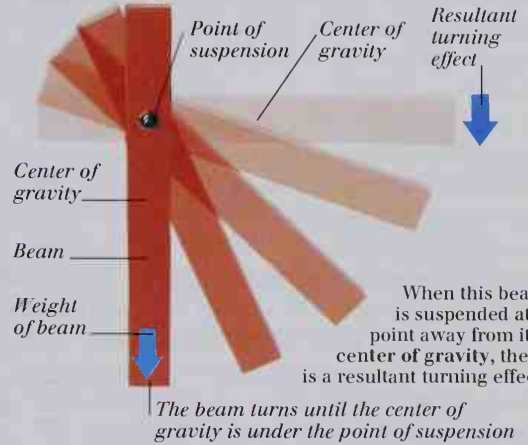

When this beam is suspended at a point away from its center of gravity, there is a resultant turning effect.

PRESSURE

Why can a thumbtack be pushed into a wall, and yet a building will not sink into the ground? Forces can act over large or small areas. A force acting over a large area will exert less pressure than the same force acting over a small area. The pressure exerted on an area can be figured out simply by dividing the applied force by the area over which it acts (see p. 378). Pressure is normally measured in newtons per square meter (Nm²) or pascals (Pa). A thumbtack concentrates force to produce high pressure, whereas the foundations of a building spread the load to reduce pressure. Gases also exert pressure (see pp. 38-39).

Mass of block: 2 kg
Weight of block: 20 N



Mass of block: 1 kg
Weight of block: 10 N

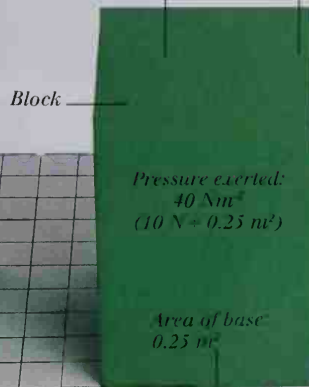

Small force exerted by thumb

Tiny area at pin point concentrates force to produce high pressure

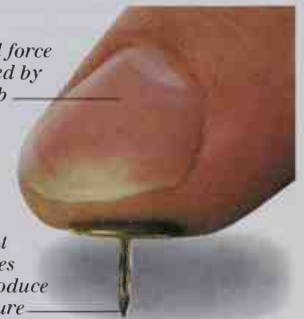

THUMB TACK

Block

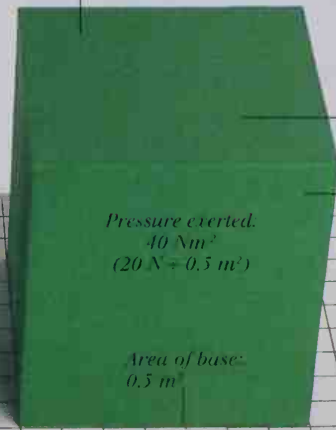

Forces 2

WHEN THE FORCES ON AN OBJECT do not cancel each other out, they will change the motion of the object. The object's speed, direction of motion, or both will change. The rules governing the way forces change the motion of objects were first figured out by Sir Isaac Newton. They have become known as Newton's Laws. The greater the mass of an object, the greater the force needed to change its motion. This resistance to change in motion is called inertia. The speed of an object is usually measured in meters per second (ms^{-1}). Velocity is the speed of an object in a particular direction. Acceleration, which only occurs when a force is applied, is the rate of change in speed. It is measured in meters per second per second, or meters per second squared (ms^{-2}). One particular force keeps the Moon in orbit around the Earth and the Earth in orbit around the Sun. This is the force of **gravity** or **gravitation**; its effects can be felt over great distances.

NEWTON'S LAWS

NEWTON'S FIRST LAW

When no force acts on an object, it will remain in a state of rest or continue its uniform motion in a straight line.



No force, no acceleration: state of rest

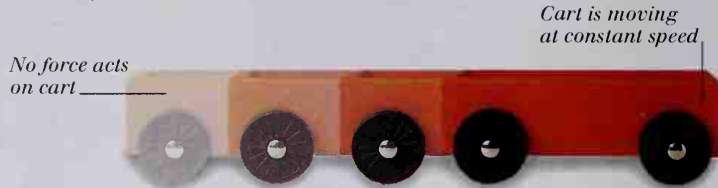

No force, no acceleration: uniform motion

NEWTON'S SECOND LAW

When a force acts on an object, the motion of the object will change. This change in motion is called acceleration and is equal to the size of the force divided by the mass of the object on which it acts (see p. 378).

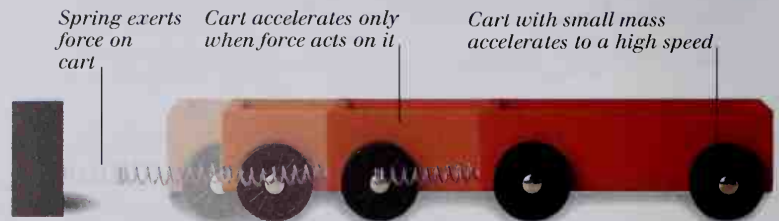

Force acts on small mass: large acceleration



Same force acts on large mass: small acceleration

NEWTON'S THIRD LAW

If one object exerts a force on another, an equal and opposite force, called the reaction force, is applied by the second to the first.

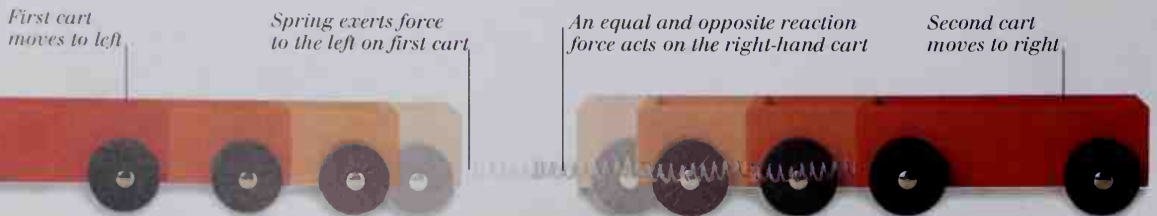

Action and reaction

NEWTON'S SECOND LAW IN ACTION

Trucks have a greater mass than cars. According to Newton's second law (see right) a large mass requires a larger force to produce a given acceleration. This is why a truck needs to have a larger engine than a car.

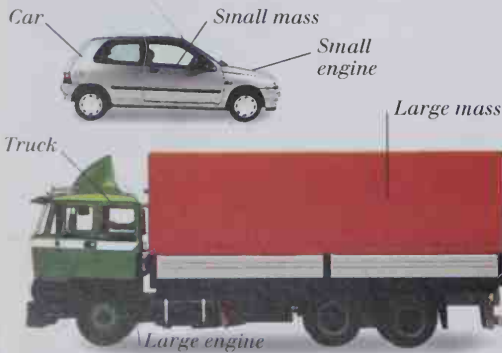

FORCE AND MOTION

In the images below, each row of balls is a record of the motion of one ball, photographed once each second beside a ruler. This shows how far the ball moved during that second and each subsequent second, giving a visual representation of speed and acceleration.

SPEED

Speed is the distance an object travels in a set amount of time. It is calculated by dividing distance covered by time taken (see p. 578). In physics, speed is measured in meters per second (ms^{-1}).

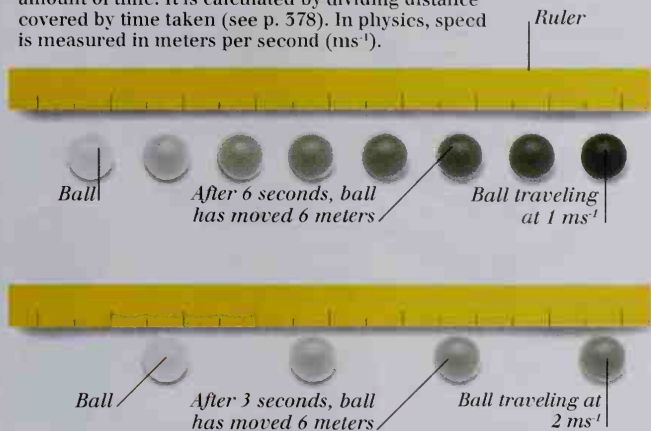

MOMENTUM

The momentum of an object is equal to its mass multiplied by its velocity (see p. 578). Momentum is measured in kilogram meters per second (kgms^{-1}). The two balls below have the same momentum.

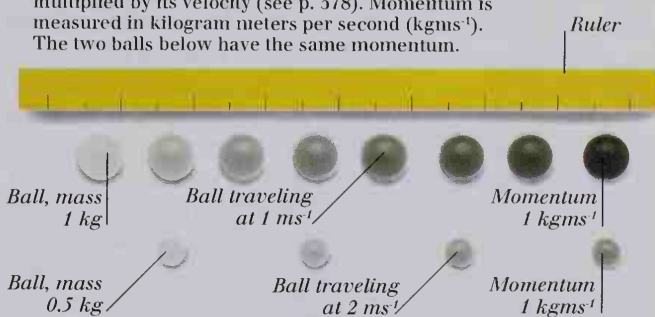

ACCELERATION

Acceleration is the rate that the speed of an object changes. It is calculated by dividing the change in speed by the time it took for that change (see p. 578). It is measured in meters per second per second (ms^{-2}).

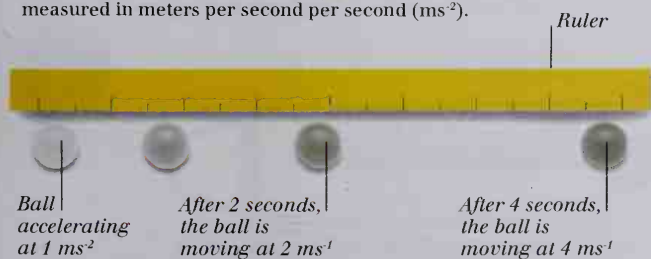

NEWTON'S SECOND LAW APPLIED TO ACCELERATION

BALL ACCELERATES AT 1 ms^{-2}



BALL ACCELERATES AT 2 ms^{-2}

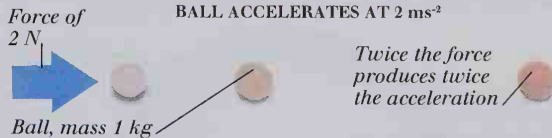

BALL ACCELERATES AT 1 ms^{-2}



GRAVITATIONAL FORCE

Gravitation, or gravity, is a force that acts on all matter. The force between any two objects depends upon their masses and the distance between them (see p. 378).

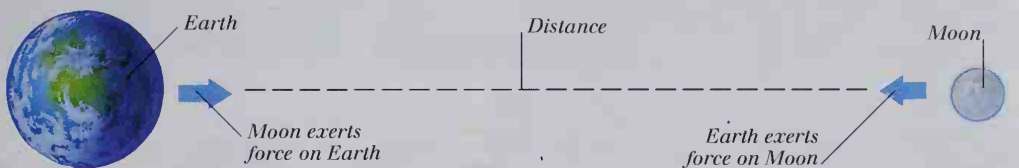

If the Moon had twice the mass that it does, the force between the Earth and Moon would be twice as large.

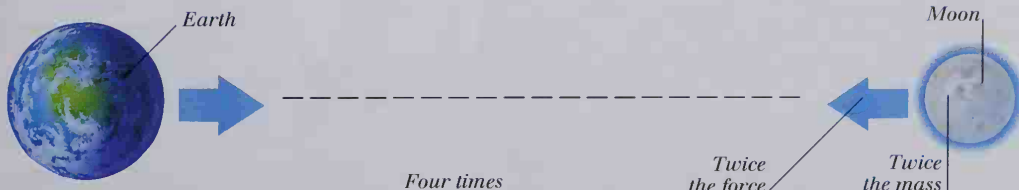

If the Moon were half the distance from the Earth, the gravitational force would be four times as large. This is because the force depends upon the distance squared.

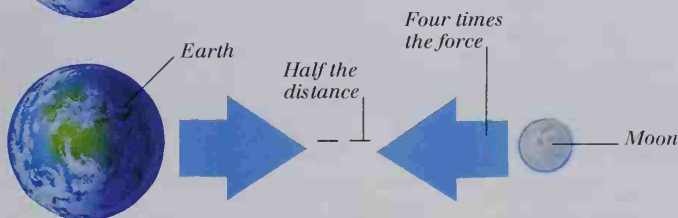

Friction

FRICITION IS A FORCE THAT SLOWS DOWN or prevents motion. A familiar form of friction is air resistance, which limits the speed at which objects can move through the air. Between touching surfaces, the amount of friction depends on the nature of the surfaces and the force or forces pushing them together. It is the joining or bonding of the atoms at each of the surfaces that causes the friction. When you try to pull an object along a table, the object will not move until the limiting friction supplied by these bonds has been overcome. Friction can be reduced in two main ways: by lubrication or by the use of rollers. Lubrication involves the presence of a fluid between two surfaces; fluid keeps the surfaces apart, allowing them to move smoothly past one another. Rollers actually use friction to grip the surfaces and produce rotation. Instead of sliding against one another, the surfaces produce turning forces, which cause each roller to roll. This leaves very little friction to oppose motion.

AIR RESISTANCE

Air resistance is a type of friction that occurs when an object moves through the air. The faster an object moves, the greater the air resistance. Falling objects accelerate to a speed called **terminal velocity**, at which the air resistance exactly balances the object's weight. At this speed, there is no resultant force and so no further acceleration can occur.

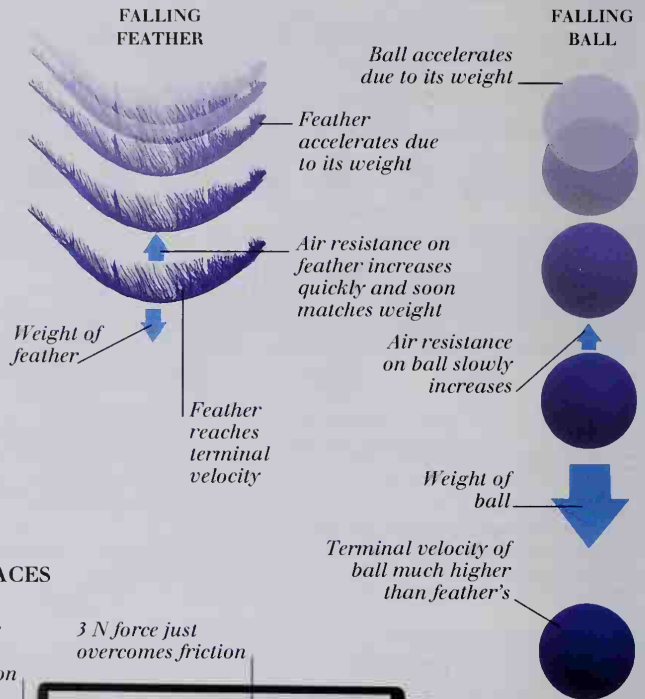

FRICITION BETWEEN SURFACES

LOW LIMITING FRICTION

Limiting friction must be overcome before surfaces can move over each other. Smooth surfaces produce little friction. Only a small amount of force is needed to break the bonds between atoms.

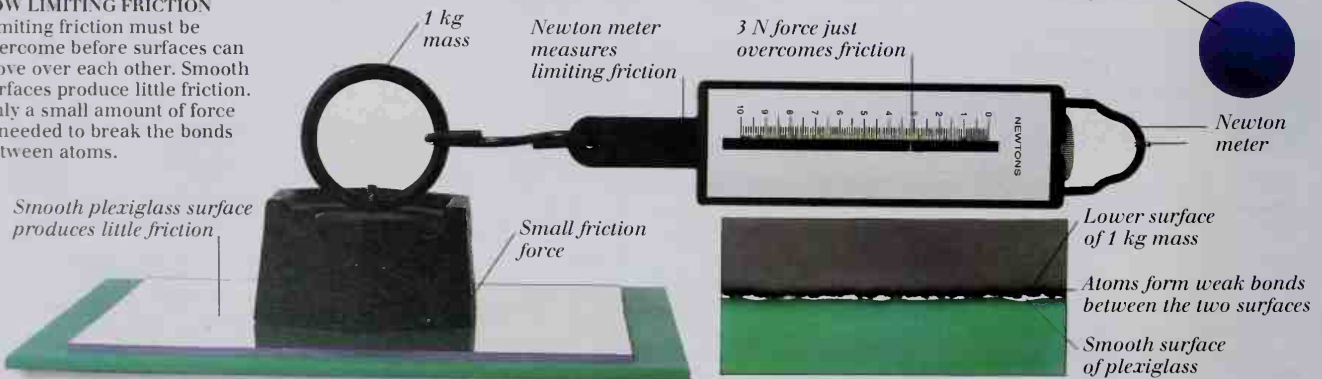

MICROSCOPIC VIEW

HIGH LIMITING FRICTION

Rougher surfaces produce a larger friction force. Stronger bonds are made between the two surfaces and more energy is needed to break them. The mass requires a large force to slide over sandpaper.

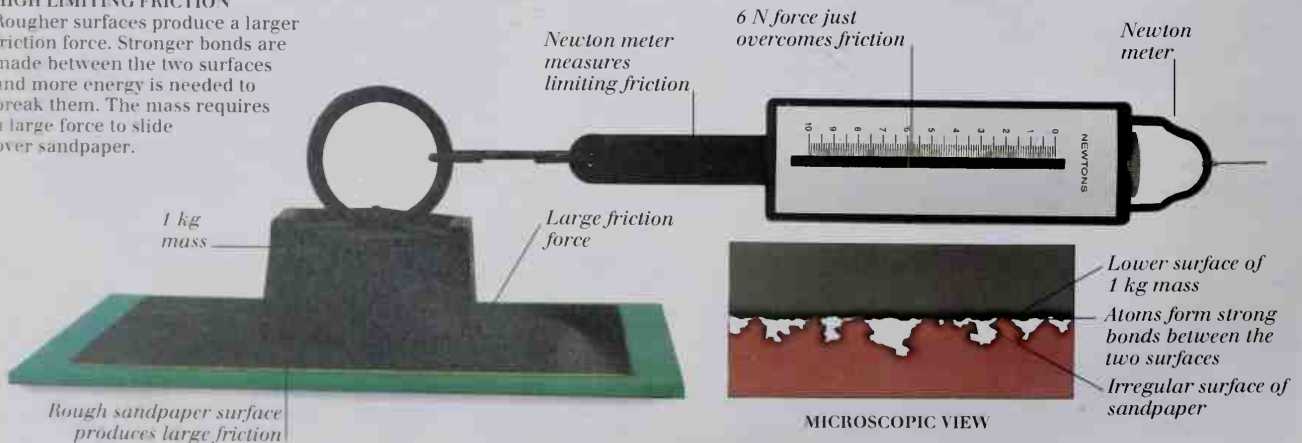

MICROSCOPIC VIEW

MOTORCYCLE BRAKE



Friction is put to good use in the disk brakes of a motorcycle. The friction force between disk and brake pad slows down the rotation of the wheel, reducing the vehicle's speed. In doing so, it converts the kinetic energy of the vehicle into heat (see p. 17).

Brake pad (inside caliper unit)
Metal brake disk

BALL BEARINGS

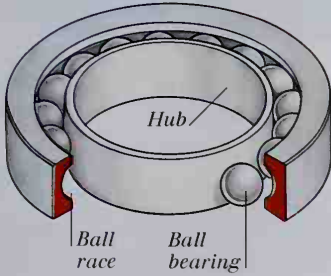

Bearings are a type of roller used to reduce friction between moving machine parts such as a wheel and its axle. As a wheel turns on its axle, the balls roll around inside the bearing, drastically reducing the friction between wheel and axle.

LUBRICATION

The presence of oil or another fluid between two surfaces keeps the surfaces apart. Because fluids (liquids or gases) flow, they allow movement between surfaces. Here, a lubricated kilogram mass slides down a slope, while an unlubricated one is prevented from moving by friction.

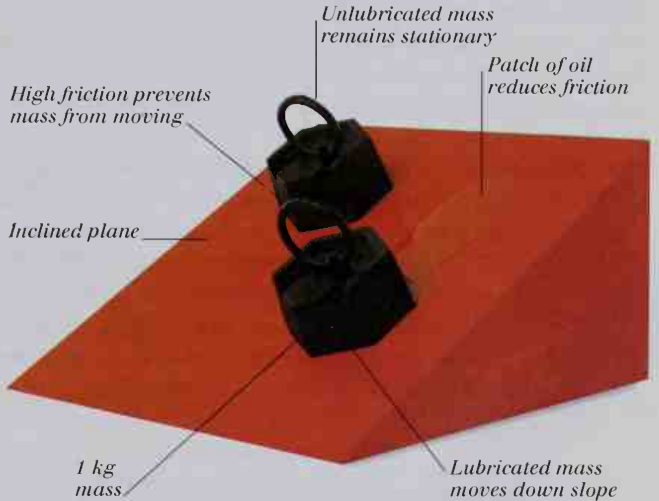

Unlubricated mass remains stationary
Patch of oil reduces friction
High friction prevents mass from moving
Inclined plane
1 kg mass
Lubricated mass moves down slope

ROLLERS

THE ACTION OF A ROLLER ON A SLOPE

Friction causes the roller to grip the slope so that it turns. If there were no friction, the roller would simply slide down the slope.

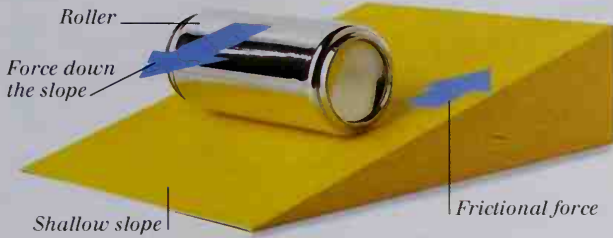

Roller
Force down the slope
Shallow slope
Frictional force



1 kg mass



Steel roller
Flat surface
Friction forces between surfaces create a turning force that turns the rollers
Mass moves smoothly over surface
Underside of 1 kg mass

USING ROLLERS TO AVOID FRICTION

Rollers placed between two surfaces keep the surfaces apart. The rollers allow the underside of the kilogram mass to move freely over the ground. An object placed on rollers will move smoothly if pushed or pulled.

Simple machines

IN PHYSICS, A MACHINE IS ANY DEVICE that can be used to transmit a force (see pp. 20-21) and, in doing so, change its size or direction. When using a simple pulley, a type of machine, a person can lift a load by pulling downward on the rope. By using several pulleys connected together as a block and tackle, the size of the force can be changed too, so that a heavy load can be lifted using a small force. Other simple machines include the inclined plane, the lever, the screw, and the wheel and axle. All of these machines illustrate the concept of work. Work is the amount of energy expended when a force is moved through a distance. The force applied to a machine is called the effort, while the force it overcomes is called the load. The effort is often smaller than the load, for a small effort can overcome a heavy load if the effort is moved through a larger distance.

The machine is then said to give a mechanical advantage. Although the effort will be smaller when using a machine, the amount of work done, or energy used, will be equal to or greater than that without the machine.

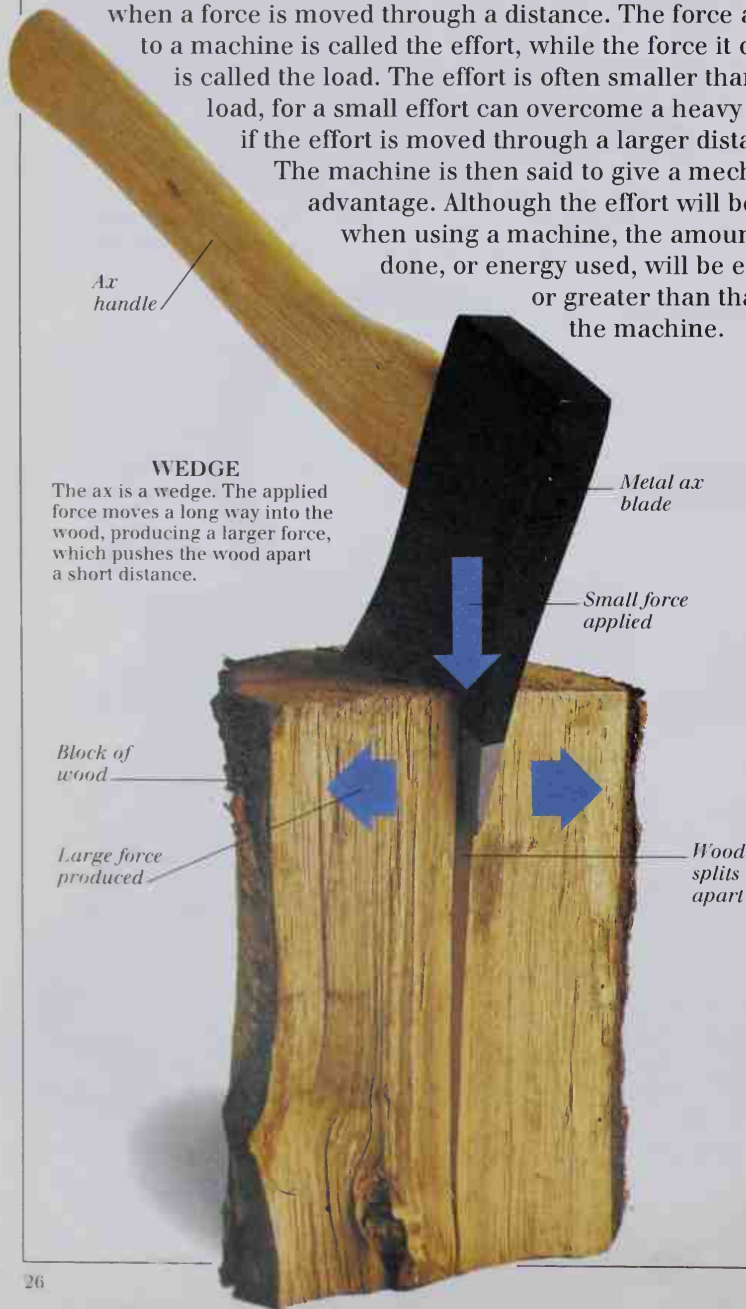

AN INCLINED PLANE
The force needed to drag an object up a slope is less than that needed to lift it vertically. However, the distance moved by the object is greater when pulled up the slope than if it were lifted vertically.

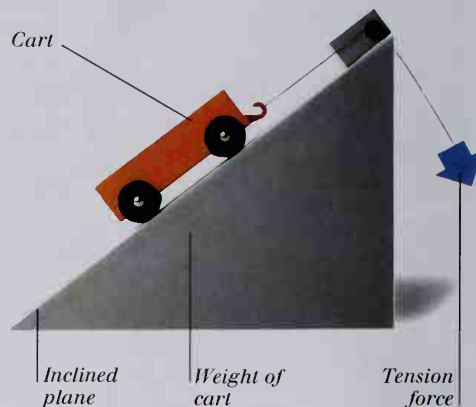

Turning force (effort)

SCREW
A screw is like an inclined plane wrapped around a shaft. The force that turns the screw is converted to a larger one, which moves a shorter distance and drives the screw in.

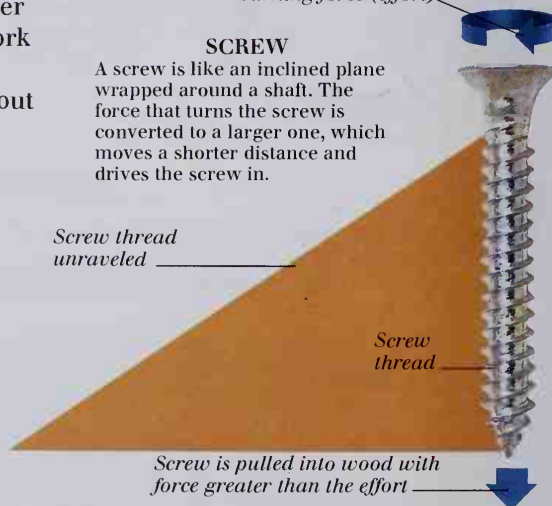

CORKSCREW
The corkscrew is a clever combination of several different machines. The screw pulls its way into the cork, turned by a wheel and axle. The cork is lifted by a pair of class one levers (see opposite).

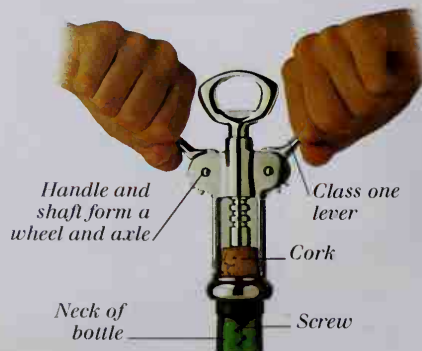

PULLEYS

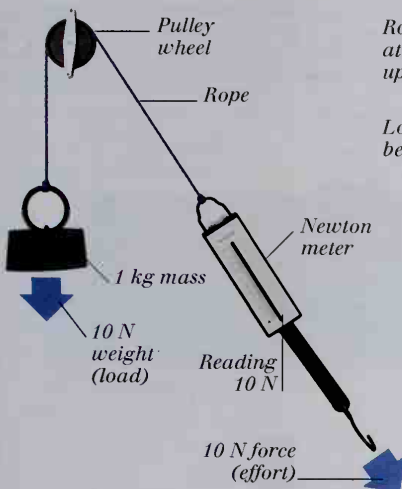
**SIMPLE PULLEY**

A simple pulley changes the direction of a force but not its size. Here a one kg mass, weighing ten newtons, is lifted by a ten newton force. The mass and the other end of the rope move through the same distance.

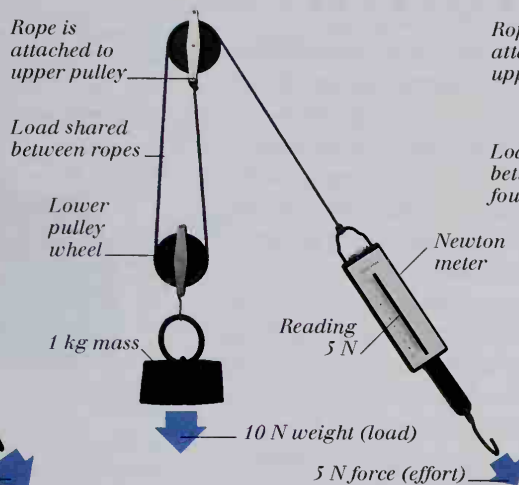
**DOUBLE PULLEY**

A double pulley will lift a one kg mass with only a five newton effort, because the force in the rope doubles up as the rope does. However, pulling the rope by one meter raises the mass by only half a meter.

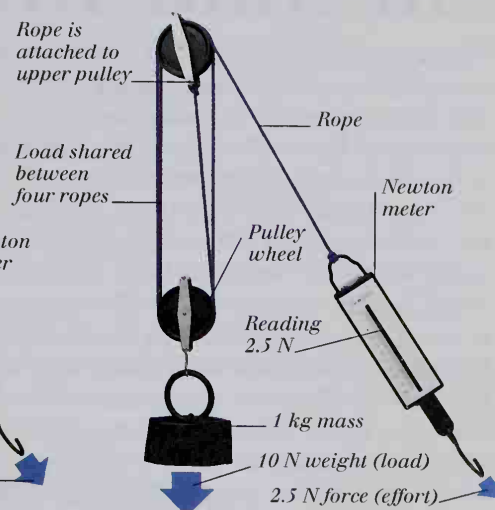
**QUADRUPLE PULLEY**

Lifting a one kg mass with a quadruple pulley, in which the rope goes over four pulley wheels, feels almost effortless. However, pulling the rope by one meter lifts the mass by only one quarter of a meter.

THREE CLASSES OF LEVERS

CLASS ONE LEVER

In a class one lever, the fulcrum (pivot point) is between the effort and the load. The load is larger than the effort, but it moves through a smaller distance.

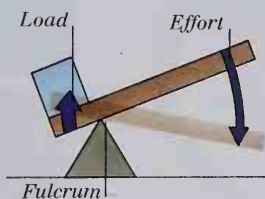
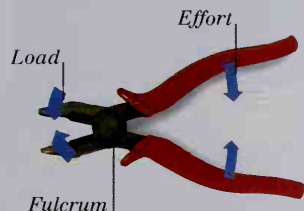
**CLASS TWO LEVER**

In a class two lever, the load is between the fulcrum and effort. Here again, the load is greater than the effort, and it moves through a smaller distance.

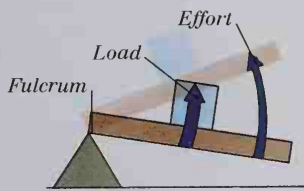
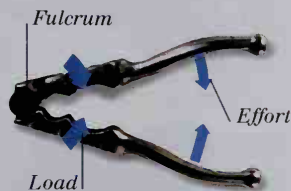
**CLASS THREE LEVER**

In a class three lever, the effort is between the fulcrum and the load. In this case, the load is less than the effort, but it moves through a greater distance.

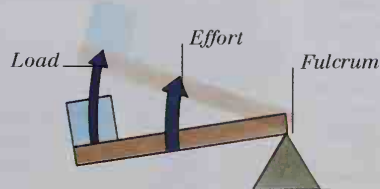
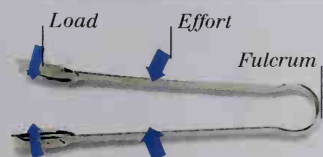

WHEEL AND AXLE

As the pedal and chainwheel of a bicycle turn through one revolution, the pedal moves farther than the links of the chain. For this reason, the force applied to the chain is greater than the force applied to the pedal. The steering wheel of a car is another example of a wheel and axle.



Circular motion

WHEN AN OBJECT MOVES IN A CIRCLE, its direction is continuously changing. Any change in direction requires a force (see pp. 22-25). The force required to maintain circular motion is called **centripetal force**. The size of this force depends on the size of the circle, and the mass and speed of the object (see p. 378). The centripetal force that keeps an object whirling around on the end of a string is caused by **tension** (see pp. 34-35) in the string. When the centripetal force ceases – for example, if the string breaks – the object flies off in a straight line, since no force is acting upon it. **Gravity** (see pp. 20-21) is the centripetal force that keeps planets such as the Earth in orbit. Without this centripetal force, the Earth would move in a straight line through space. On a smaller scale, without friction to provide centripetal force, a motorcyclist could not steer around a bend. Spinning, a form of circular motion, gives **gyroscopes** stability.

MOTION IN A CIRCLE

ASPECTS OF CIRCULAR MOTION

The force that continuously changes the direction of an object moving in a circle is called centripetal force. It is directed toward the center of the circle. The smaller the radius of the circle, the larger the force needed.

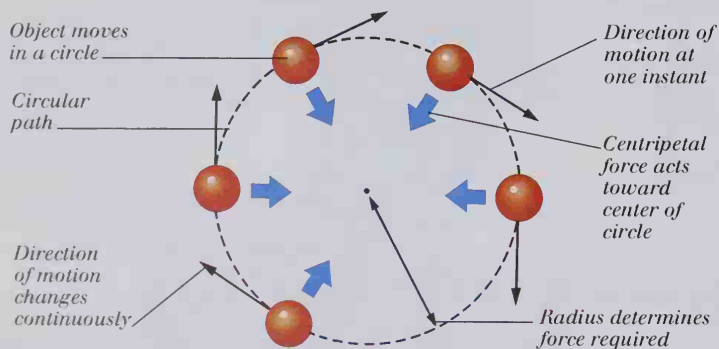

HAMMER THROWER

Tension in muscles provides the centripetal force needed to whirl a hammer round in a circle. When the thrower releases the chain, no force acts upon the hammer, and it moves off in a straight line.

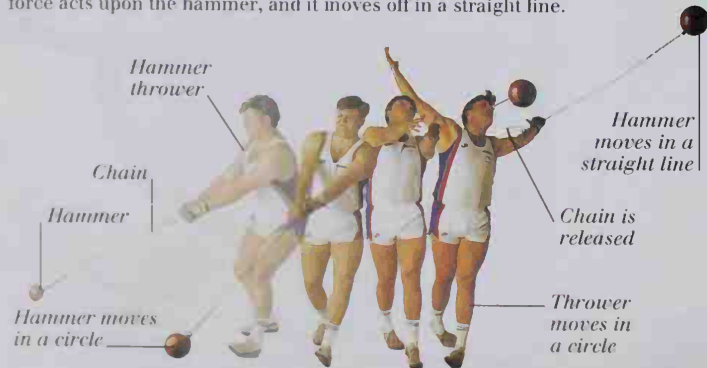

CENTRIPETAL FORCE

In the experiment below, centripetal force is provided by tension in a length of string, which keeps a 1 kg mass moving in a circle. The mass can move freely as it floats like a hovercraft on the jets of air supplied from beneath it. When the circle is twice as large, half the force is needed. However, moving twice as fast requires four times the force (see p. 378).

CONTROL EXPERIMENT

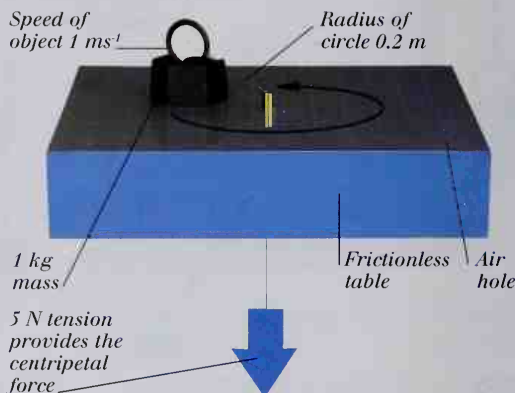

TWICE THE SPEED, FOUR TIMES THE FORCE

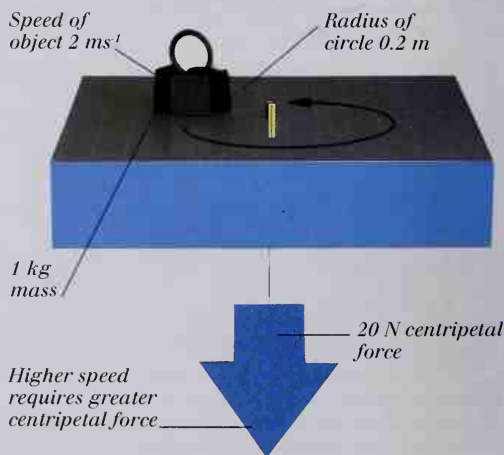

TWICE THE RADIUS, HALF THE FORCE

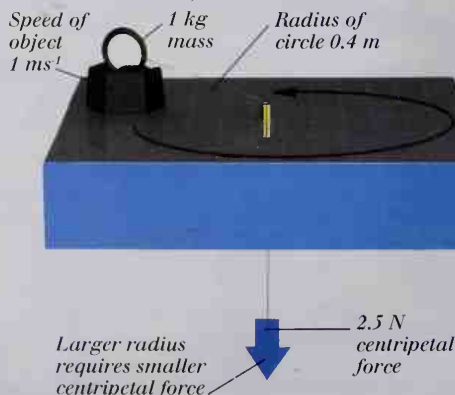

PLANETARY ORBITS

GRAVITATIONAL FORCES

The orbit of a planet around the Sun is an ellipse (like a flattened circle). Centripetal force is needed to keep the planets from moving off in a straight line into outer space. Gravity provides this centripetal force. It acts toward the center of the Solar System, the Sun. Venus is roughly the same mass as the Earth, but travels much faster. This is possible because Venus is closer to the Sun, so the force of gravity, and therefore the centripetal force, is much larger (see p. 378).

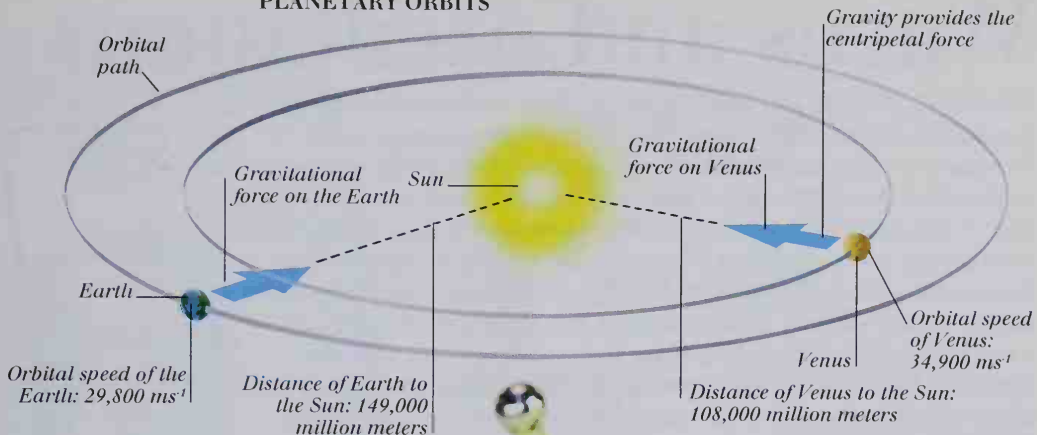

TURNING A CORNER

FRICITION

One of the forces acting on a motorcycle as it turns a bend is the centripetal force caused by the friction between the tires and the road. Without this friction, for example on an icy surface, a motorcycle would simply continue in a straight line.

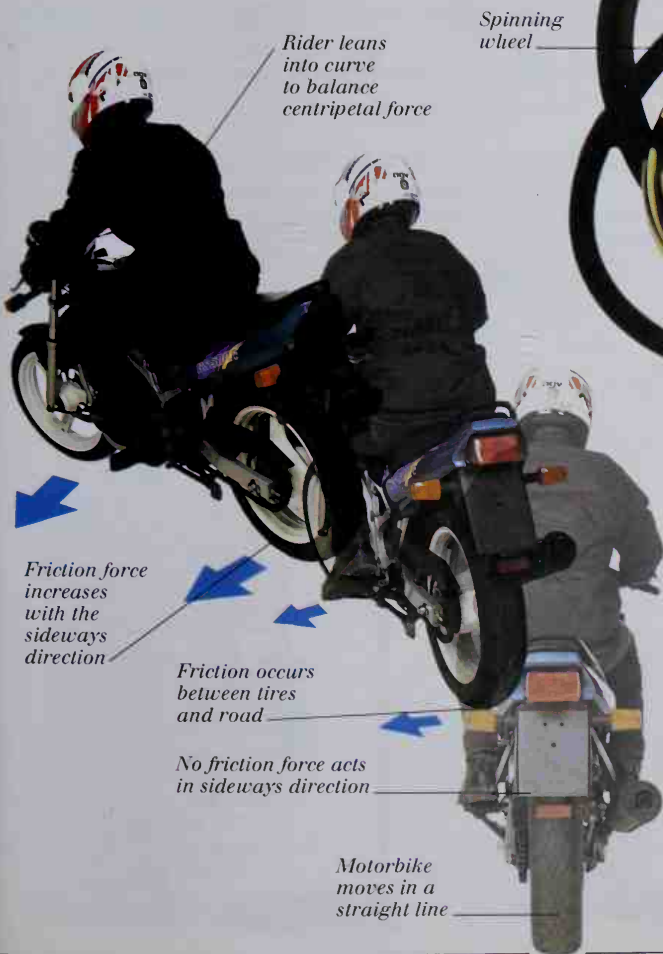

GYROSCOPE



ANGULAR MOMENTUM

Any spinning object, like a wheel or a top, will behave like a gyroscope. Once spinning, a gyroscope possesses angular momentum. This gives the gyroscope stability. The force of gravity acting on the gyroscope will not topple it. As gravity tries to tilt the axis, its axis moves at right angles to gravity's force. This causes a motion called precession, in which the axis traces a small circle.

Waves and oscillations

AN OSCILLATION IS ANY MOTION BACK AND FORTH, such as that of a pendulum. When that motion travels through matter or space, it becomes a wave. An oscillation, or vibration, occurs when a force acts that pulls a displaced object back to its **equilibrium** position, and the size of this force increases with the size of the **displacement**. A mass on a spring, for example, is acted upon by two forces: **gravity** and the **tension** (see pp. 38-39) in the spring. At the point of equilibrium, the **resultant** (see pp. 20-21) of these forces is zero: they cancel each other out. At all other points, the resultant force acts in a direction that restores the object to its equilibrium position. This results in the object moving back and forth, or oscillating, about that position. Vibration is very common and results in the phenomenon of sound. In air, the vibrations that cause sound are transmitted as a wave between air molecules; many other substances transmit sound in a similar way.

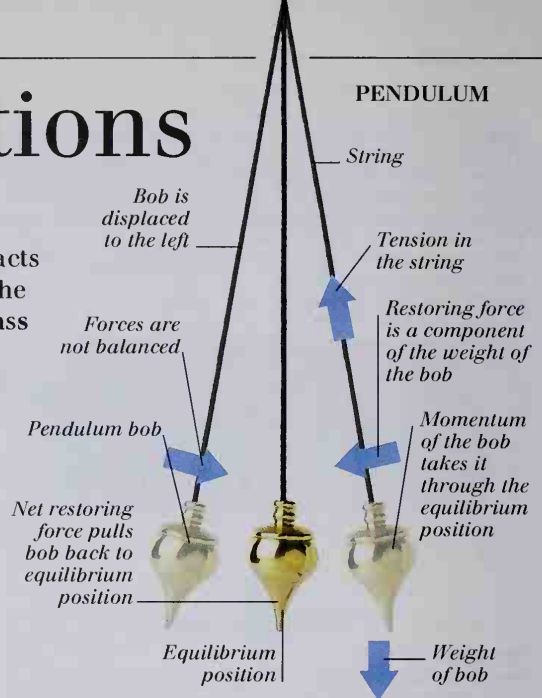

WAVES IN SPRINGS

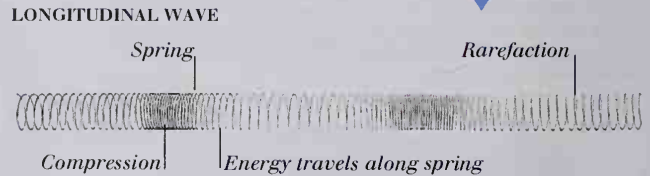
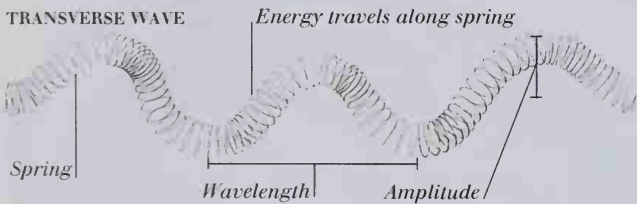

OSCILLATION

MOTION OF MASS ON SPRING

The first mass shown (below left) is in equilibrium. The two forces acting on it – its **weight** and the **tension** in the spring – exactly cancel each other out. The mass is given an initial downward push. Once the mass is displaced downward (below center), the tension in the spring exceeds the weight. The resultant upward force accelerates the mass back up toward its original position, by which time it has momentum, carrying it farther upward. When the weight exceeds the tension in the spring (below right), the mass is pulled down again. This cycle repeats.

MOTION OF MASS ON SPRING, MASS SEEN IN ISOLATION

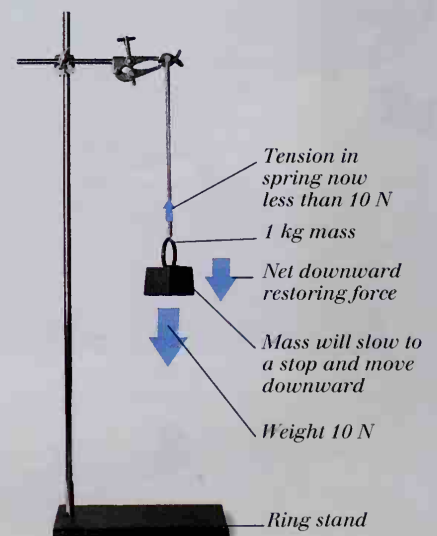
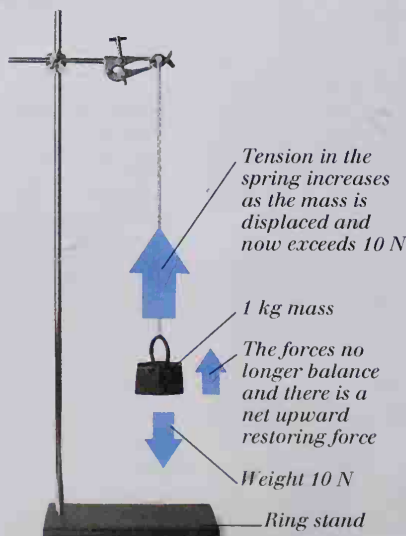
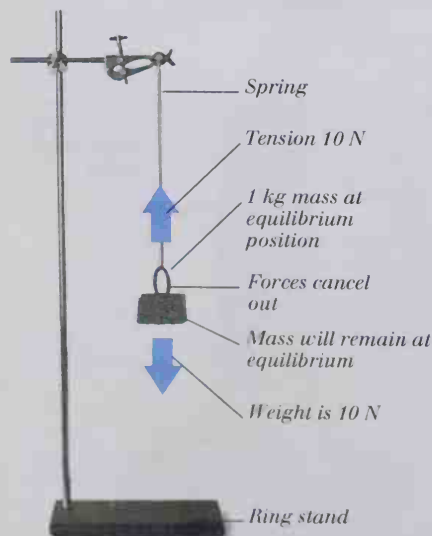

SOUND AS VIBRATION OF THE AIR

PROPAGATION OF SOUND

A vibrating object, such as the tuning fork shown here, causes variations in pressure in the surrounding air. Areas of high and low pressure, known as **compressions** and **rarefactions**, propagate (move) through the air as sound waves. The sound waves meet a microphone and create electrical oscillations displayed on an oscilloscope.

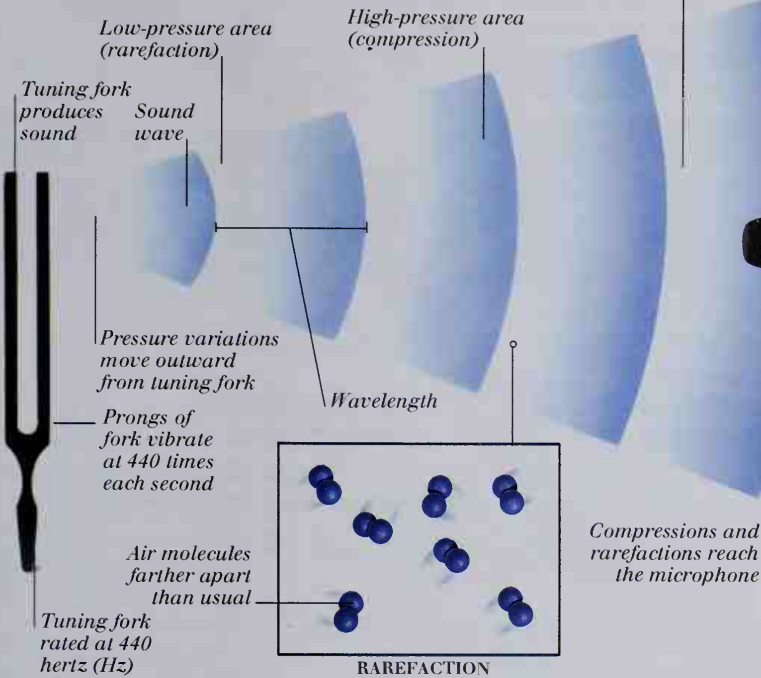

The compression travels as a wave at about 330 meters per second

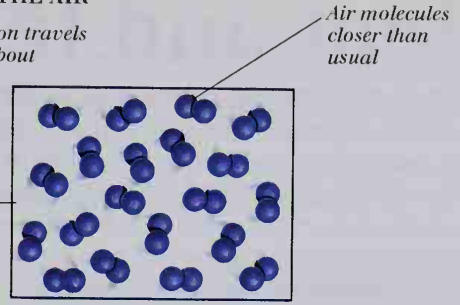

COMPRESSION

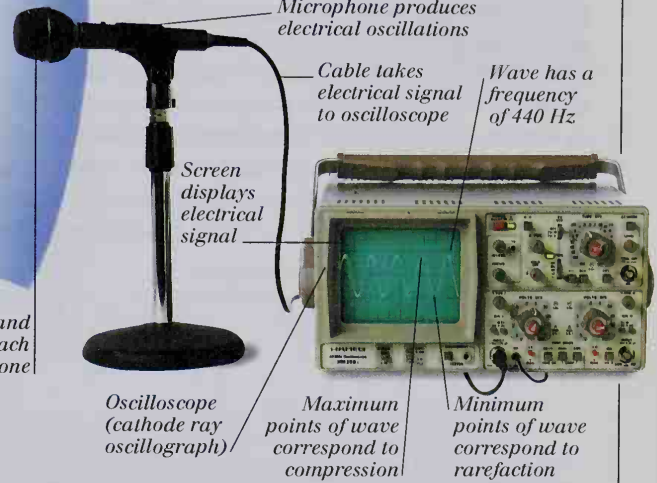

NOTES PRODUCED BY COLUMNS OF AIR

FREQUENCY AND WAVELENGTH

The distance between each compression of a sound wave is called its **wavelength**. Sound waves with a short wavelength have a high frequency and sound high-pitched. The frequency of a note is the number of vibrations each second and is measured in hertz (Hz). The columns of air in these jars produce different notes when air is blown over them.



LOUDSPEAKER

A changing electrical signal is fed to the voice coil of a loudspeaker, which lies within the magnetic field of a permanent magnet. The signal in the coil causes it to behave like an electromagnet (see pp. 44-45), making it push against the field of the permanent magnet. The speaker cone is then pushed in and out by the coil in time with the signal.

If the signal is from a sound recording, the original sound will be reproduced

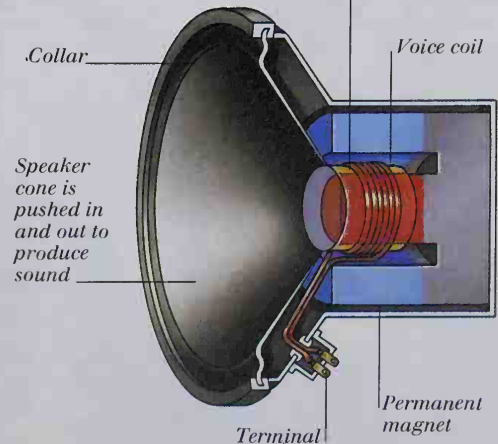

Heat and temperature

HEAT IS A FORM OF ENERGY (see pp. 16-17). This energy is the **kinetic energy** of the atoms and molecules that make up all matter. The temperature of a substance is related to the average kinetic energy of its particles. Units of temperature include the degree **Celsius** (°C), the degree **Fahrenheit** (°F), and the **Kelvin** (K). Some examples of equivalent values are shown below. The lowest possible temperature is called **absolute zero** (zero K). At this temperature, atoms and molecules have their lowest energy. The **state of a substance** is determined by its temperature and most substances can exist as a solid (see pp. 54-55), a liquid (see pp. 56-57), or a gas (see pp. 58-59). If two substances at different temperatures make contact, their particles will share their energy. This results in a heat transfer by **conduction**, until the temperatures are equal. This process can melt a solid, in which case the heat transferred is called **latent heat**. Heat can also be transferred by **radiation**, in which heat energy becomes electromagnetic radiation (see pp. 48-49), and does not need a material medium to transfer heat.

RANGE OF TEMPERATURES

About 14 million K
(14 million °C,
25 million °F):
Center of the Sun

30,000K
(30,000°C,
54,000°F):
Average bolt
of lightning

5,800K (5,530°C, 10,000°F):
Surface of the Sun

3,300K (3,027°C; 5,480°F):
Metals can be welded

1,808K (1,535°C, 2,795°F):
Melting point of iron

933K (660°C, 1,220°F):
Natural gas flame

600K (327°C, 620°F):
Melting point of lead

523K (250°C, 482°F):
Wood burns

457K (184°C, 363°F):
Paper ignites

373.15K (100°C, 212°F):
Boiling point of water

331K (58°C, 136°F):
Earth's highest
temperature

184K (-89°C, -128°F):
Earth's lowest
temperature

73K (-200°C,
-328°F): Air
liquefies

0K (-273.15°C,
-459.67°F):
Absolute zero

234K (-39°C,
-38.2°F):
Freezing point
of mercury

273.15K (0°C, 32°F):
Freezing point of
water

TEMPERATURE SCALES
All temperature scales except the Kelvin scale (K) need two or more reference temperatures, such as boiling water and melting ice. Under controlled conditions, these two temperatures are fixed.

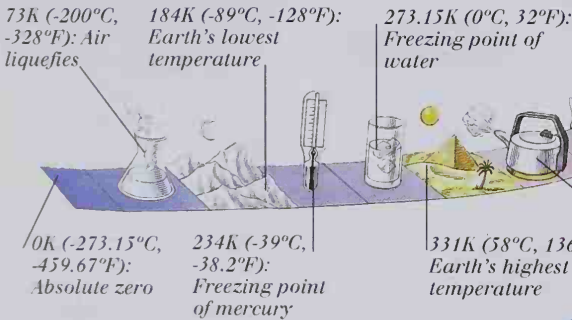

STATES OF MATTER

SUPERCOOLED LIQUID
The particles of a **supercooled liquid** are in fixed positions, like those of a solid, but they are disordered and cannot be called a true solid. Supercooled liquids flow very slowly and have no definite melting point.

SOLID
The particles of a solid normally have no motion relative to each other, as they are only free to vibrate about a fixed position. An input of energy breaks the bonds between particles, and the solid melts.

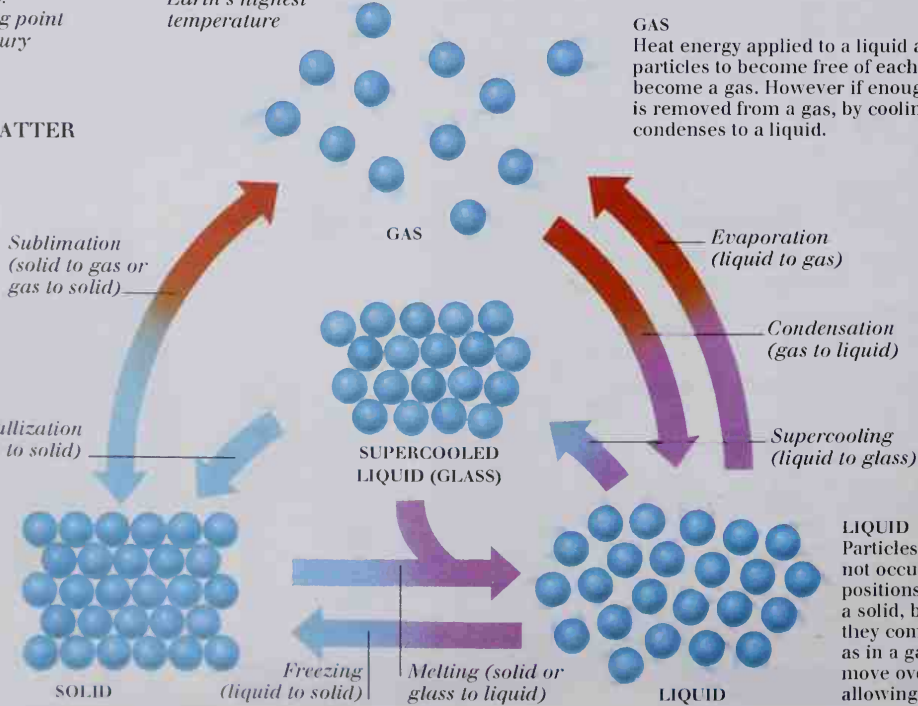

GAS
Heat energy applied to a liquid allows particles to become free of each other and become a gas. However if enough energy is removed from a gas, by cooling, it condenses to a liquid.

LIQUID
Particles in a liquid do not occupy fixed positions like those in a solid, but neither are they completely free, as in a gas. The particles move over one another, allowing a liquid to flow.

OBJECTS AT DIFFERENT TEMPERATURES

The particles of objects at different temperatures have different kinetic energies. The colors of the blocks below are an indication of their temperature.

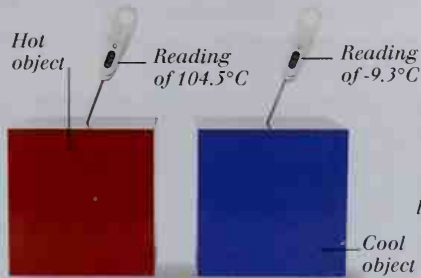

BLOCKS SEPARATED

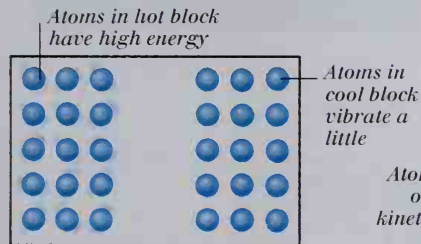

MOLECULAR VIEW

EQUALIZATION OF TEMPERATURES

TRANSFER OF HEAT

When two objects at different temperatures are brought into contact, a transfer of kinetic energy takes place in the form of heat. Here, the hot and cold blocks are touching.

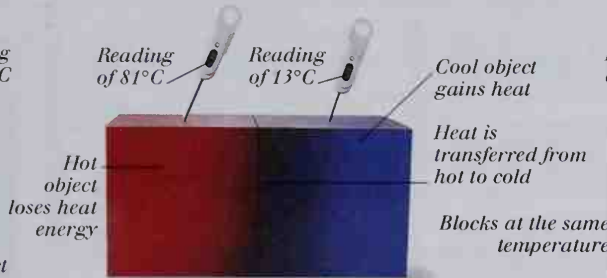

BLOCKS IN CONTACT

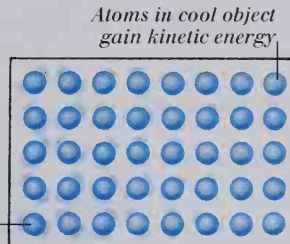

MOLECULAR VIEW

EQUAL TEMPERATURES

Eventually, the average kinetic energies of particles in two touching objects become equal. The temperatures of the two objects are then said to be equal, as shown by the blocks below.

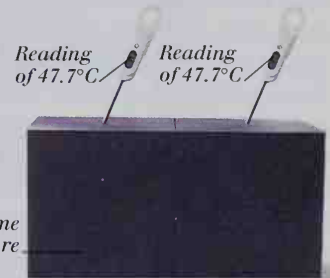

NO FURTHER HEAT TRANSFER

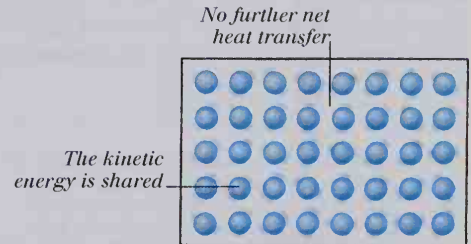

MOLECULAR VIEW

LATENT HEAT

HEATING A SUBSTANCE

Heat transferred from a hot flame to a cooler substance can cause the substance to melt. The temperature of the substance (here, naphthalene) rises with the transfer of more energy, until it reaches the melting point.

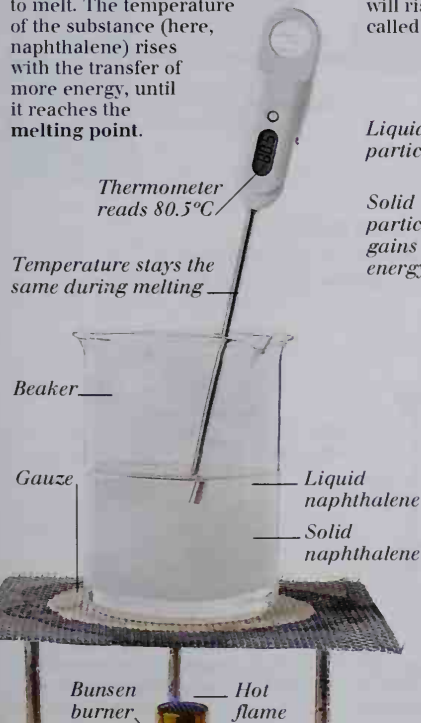

MELTING A SUBSTANCE

At the melting point, the supplied energy must break the attraction between all the particles, melting all the solid, before the temperature will rise again. This extra supplied energy is called latent heat.

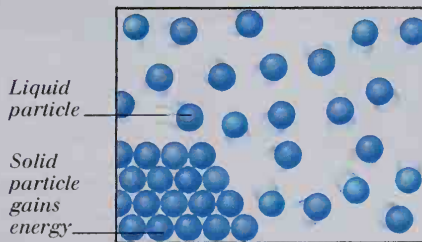

MELTING

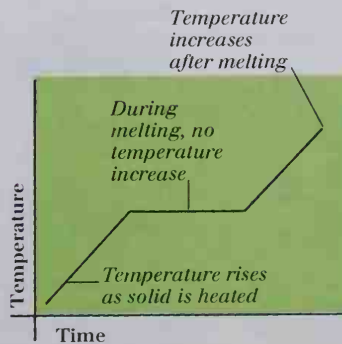

GRAPH TO SHOW MELTING

TRANSFER OF HEAT BY RADIATION

An object at room temperature produces radiation – called infrared radiation. A hot object, such as the lamp below, produces a lot of infrared. This radiation can heat up other objects. The hot object cools as it loses energy as radiation.

Metal block at room temperature

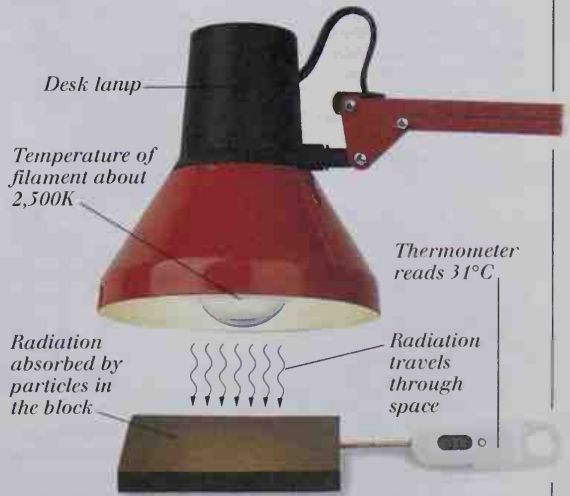

RADIATION

Solids

THE ATOMS OF A SOLID ARE CLOSELY PACKED, giving it a greater **density** than most liquids and all gases. A solid's rigidity derives from the strong attraction between its atoms. A force pulling on a solid moves these atoms farther apart, creating an opposing force called **tension**. If a force pushes on a solid, the atoms move closer together, creating **compression**. Temperature (see pp. 32-33) can also affect the nature of a solid. When the temperature of a solid increases, its particles gain **kinetic energy** and vibrate more vigorously, resulting in **thermal expansion**. Most solids are **crystals**, in which atoms are arranged in one of seven regular, repeating patterns (see below). **Amorphous** solids, such as glass, are not composed of crystals and can be molded into any shape. When the atoms of a solid move apart, the length of the solid increases. The extent of this increase depends on the applied force, and on the thickness of the material, and is known as **elasticity**.

STEEL RAILS

The expansion of a solid with an increase in temperature (see below) would cause rails to buckle badly in hot weather. To prevent this, rails are made in sections. The gap between the two sections allows each section to expand without buckling.

Train can pass smoothly over diagonal joint Expansion joint



THERMAL EXPANSION

EXPERIMENT TO SHOW THERMAL EXPANSION

When a substance is heated, its atoms gain kinetic energy. In a solid, this results in the atoms vibrating more vigorously about their fixed positions. As a result, solids expand when heated. Below, a thin steel rod is heated by a gas flame, and the resulting expansion is measured using a micrometer.

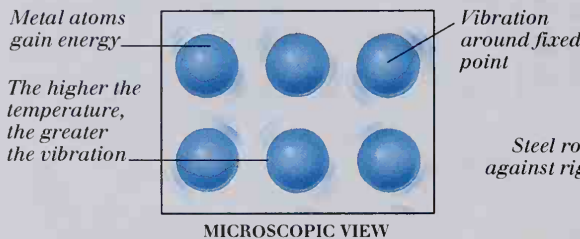

Steel rod pushes against rigid block

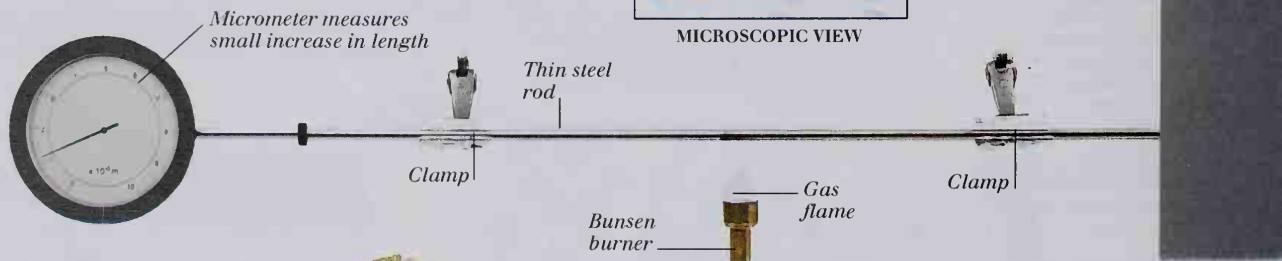

EXTERNAL FEATURES
The seven crystal systems are based on the external shapes of crystals, but they also correspond to the arrangement of atoms within. The basic arrangement that is repeated in the crystal is called the **unit cell**.



THE SEVEN CRYSTAL SYSTEMS

The unit cell of each crystal system has an identifiable form, based on hypothetical axes composed by joining up the particles of the cell. A group of unit cells form a **crystal lattice**.

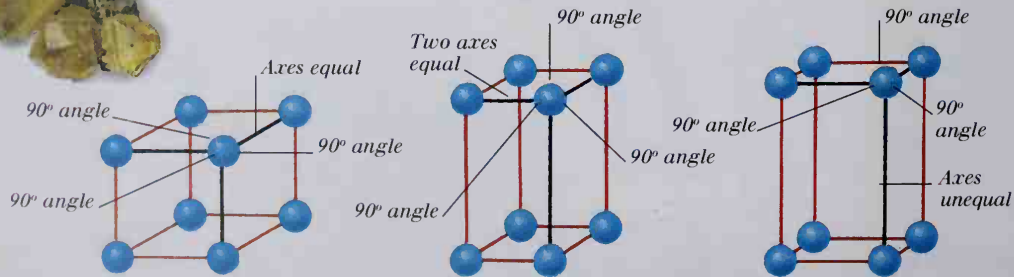

CUBIC SYSTEM
Atoms in a cubic system are equally spaced, and the angle between each axis of the repeating cell is always 90°.

TETRAGONAL SYSTEM
All of the angles within the cell are 90°, and of the three axes (shown in black), two are the same length.

ORTHORHOMBIC SYSTEM
All of the angles within the cell are 90°, but none of the three axes (shown in black) is equal in length.

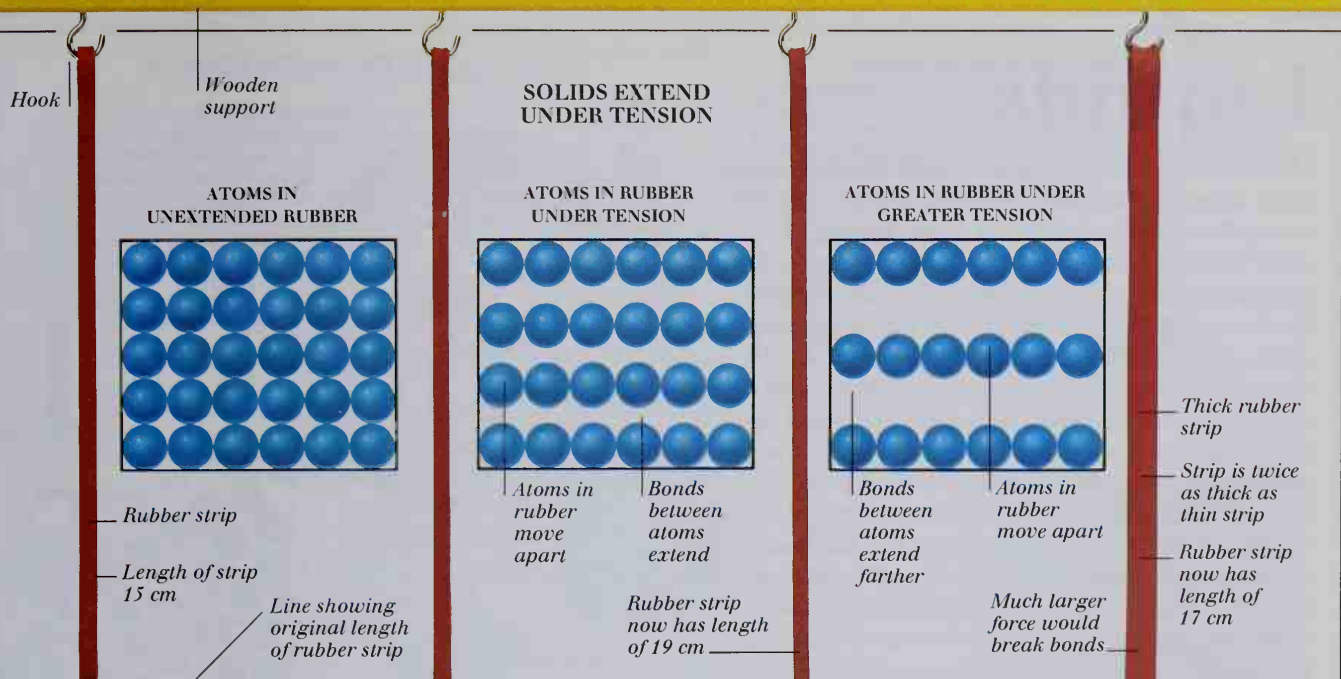

EXPERIMENT TO TEST ELASTICITY
 An elastic substance is a solid that gets larger (extends) under tension, gets smaller under compression, and returns to its original size when no force acts on it. All nonamorphous solids are to a certain extent elastic. This experiment, which tests rubber under different degrees of tension, shows that twice the tension force results in twice the extension.

CROSS-SECTIONAL AREA
 Another factor involved in elasticity is the cross-sectional area of the material involved. The thick rubber strip (above) extends less under the same tension than the thinner one (above left).

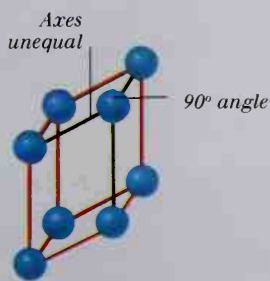

MONOCLINIC SYSTEM
 Two of the axes of the cell meet at 90° . No two axes (shown in black) are equal in length.

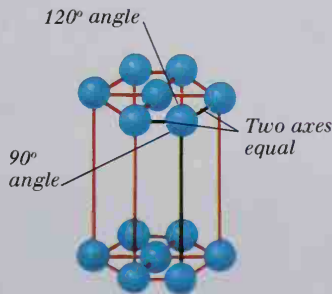

HEXAGONAL SYSTEM
 The edges form angles of 120° and 90° . Two of the three axes (shown in black) are equal in length.

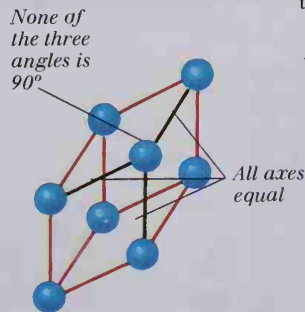

TRIGONAL SYSTEM
 No two edges meet at 90° . All of the edges are equal in length.

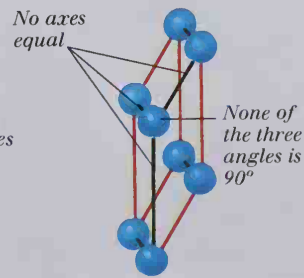

TRICLINIC SYSTEM
 No two edges meet at 90° . No two axes (shown in black) are equal in length.

Liquids

UNLIKE SOLIDS, LIQUIDS CAN FLOW. Their particles move almost independently of each other but are not as free as the particles of a gas. Forces of attraction called **cohesive forces** act between the particles of a liquid. These forces create **surface tension**, which pulls liquid drops into a spherical shape. If the surface tension of water is reduced, by dissolving soap in it, then pockets of air can stretch the surface into a thin film, forming a bubble. Forces of attraction between liquid particles and adjoining matter are called **adhesive forces**. The balance between cohesive and adhesive forces causes **capillary action**, and the formation of a **meniscus** curve at the boundary between a liquid and its container. Liquids exert pressure on any object immersed in them; the pressure acts in all directions and increases with depth, creating **upthrust** on an immersed object. If the upthrust is large enough, the object will float.

LIQUID DROPS AND BUBBLES

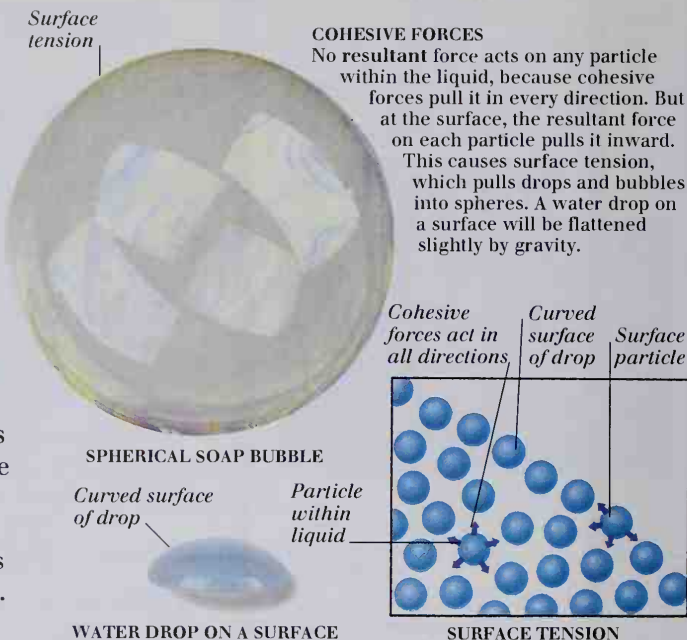

LIQUIDS IN TUBES

CAPILLARY ACTION

Water adheres to glass. This adhesion can lift water up into a glass tube; an effect known as capillary action.

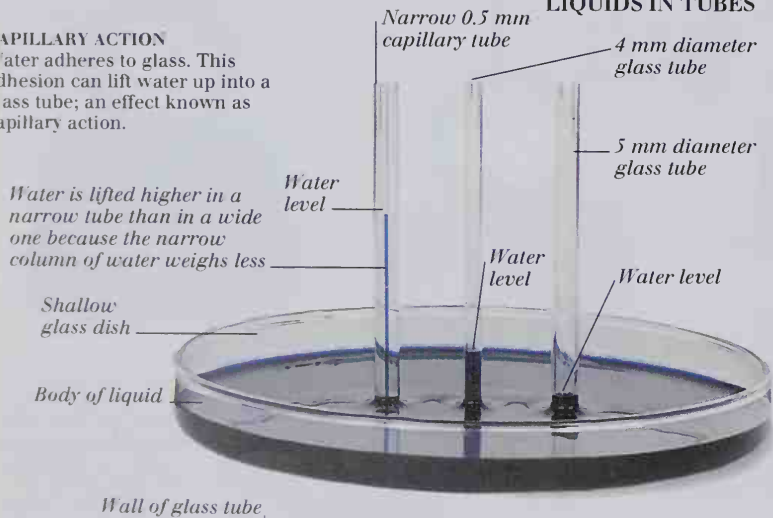

MENISCUS

Where a liquid meets a solid surface, a curve called a meniscus forms. The shape of the meniscus depends on the balance between cohesive and adhesive forces.

DOWNWARD MENISCUS

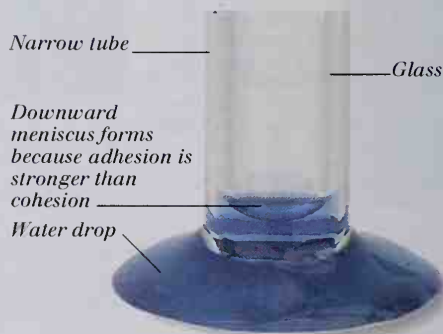

UPWARD MENISCUS

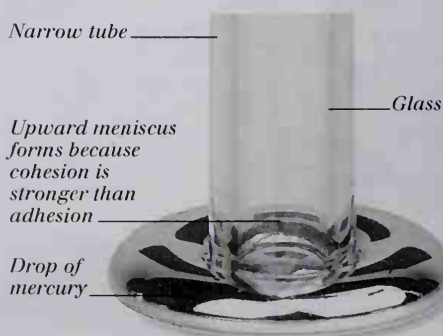

MOLECULAR VIEW

Capillary action is caused by adhesive and cohesive forces between particles of glass and water. Here, water molecules adhere to glass and the adhesive force lifts the edge of the water up the glass. The cohesive forces between water molecules means that this lifted edge also raises water molecules lying farther out from the edge of the glass.

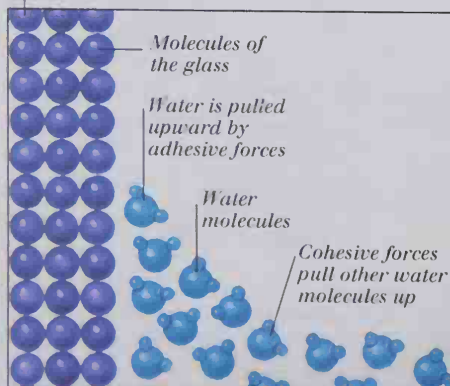

UPTHRUST ON IMMERSED OBJECTS

Liquids exert pressure on immersed objects, resulting in an upward resultant force called upthrust. The upthrust is equal to the weight of liquid displaced by the immersed object. Here, a 1 kg mass, weighing 10 N in air, displaces water weighing 1.2 N. Consequently the apparent weight of the submerged mass is 8.8 N ($10\text{ N} - 1.2\text{ N}$).

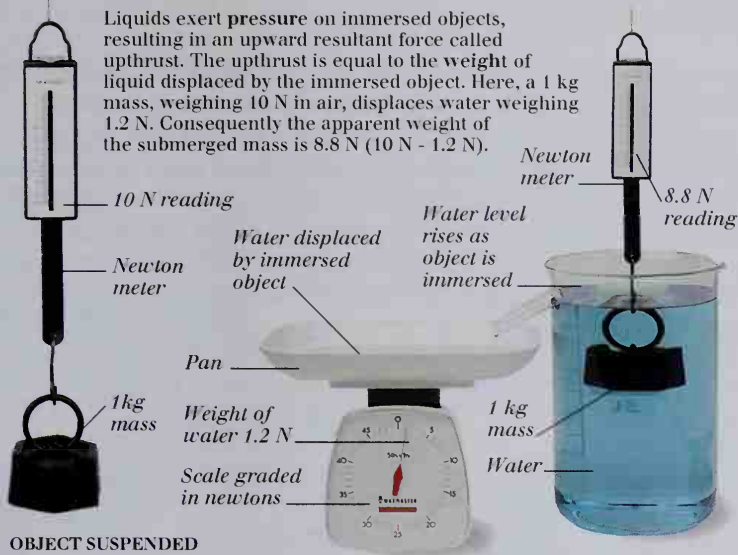

OBJECT SUSPENDED IN AIR

OBJECT IMMERSED IN WATER

UPTHRUST AT WORK

If the upthrust on an object is greater than the weight of the object, then the object will float. Large metal ships float, because their shape means that they displace huge amounts of water, producing a large upthrust.



Metal hull

Upthrust force from the water equals the downward force of the ship's weight

THE WATER JETS

The water in the jets coming from the tank breaks into drops as it falls. Surface tension pulls the water into drops as the jet weakens and cohesive forces keep the drops in a near spherical shape. When the drops fall into the tray, they form a pool. Unlike solids, liquids can flow, so under the influence of gravity the surface of this pool becomes flat and horizontal.

Shallow tray Flat and horizontal surface Colored water



PRESSURE INCREASES WITH DEPTH

The pressure at any point in a liquid depends on the weight of liquid above that point. So pressure increases with depth. In the experiment shown below, water from a large tank escapes through holes at various depths. The greater the pressure, the faster the water escapes.

The pressure of a liquid is measured in newtons per square meter (Nm^{-2})

Atmospheric pressure above the water's surface is $100,000\text{ Nm}^{-2}$

Pressure gauge

Clear plastic tank

Pressure at 0.1 m depth is $101,000\text{ Nm}^{-2}$

Only a dribble of water escapes

Water escapes quickly

Pressure at 0.2 m depth is $102,000\text{ Nm}^{-2}$

Pressure at 0.3 m depth is $103,000\text{ Nm}^{-2}$

Stream is almost horizontal

Water escapes very quickly

Colored water

Water pressure greatest at the base of the tank

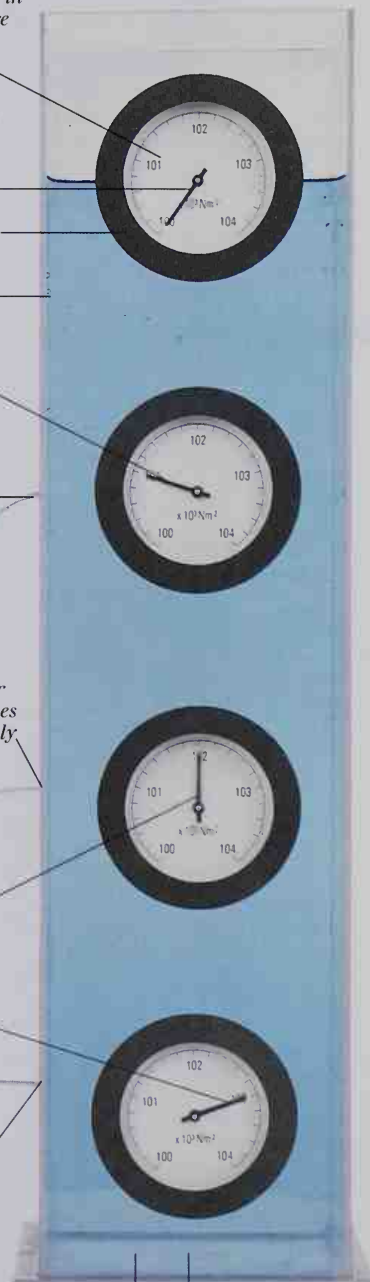

Gases

A GAS COMPRISES INDEPENDENT PARTICLES – atoms or molecules – in random motion. This means that a gas will fill any container into which it is placed. If two different gases are allowed to meet, the particles of the gases will mix together. This process is known as **diffusion**. Imagine a fixed mass of gas – that is, a fixed number of gas particles. It will occupy a particular amount of space, or **volume**, often confined by a container. The particles of the gas will be in constant, random motion. The higher the **temperature** of the gas (see pp. 32-33), the faster the particles move. The bombardment of particles against the sides of the container produces **pressure** (see pp. 20-21). Three simple laws describe the predictable behavior of gases. They are Boyle's Law, the Pressure Law, and Charles' Law. Each of the gas laws describes a relationship between the pressure, volume, and temperature of a gas.

DIFFUSION

The random movement of gas particles ensures that any two gases sharing the same container will totally mix. This is diffusion. In the experiment below, the lower gas jar contains bromine, the top one air.

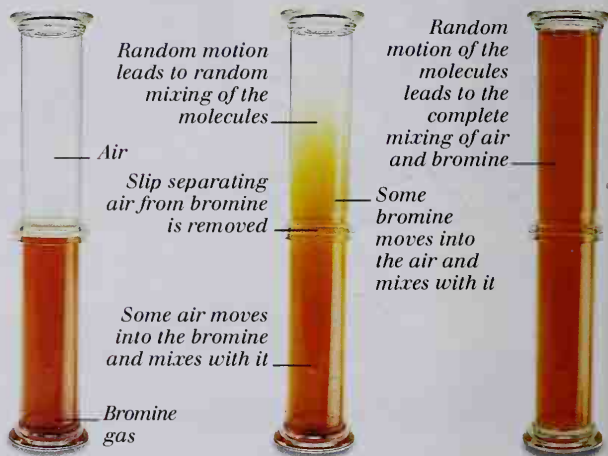

BOYLE'S LAW

The volume of a mass of gas at a fixed temperature will change in relation to the pressure. If the pressure on a gas increases, its volume will decrease. The apparatus on the left is used to illustrate Boyle's Law. A foot pump is used to push a column of oil up a sealed tube, reducing the volume occupied by the gas in the top part of the tube.

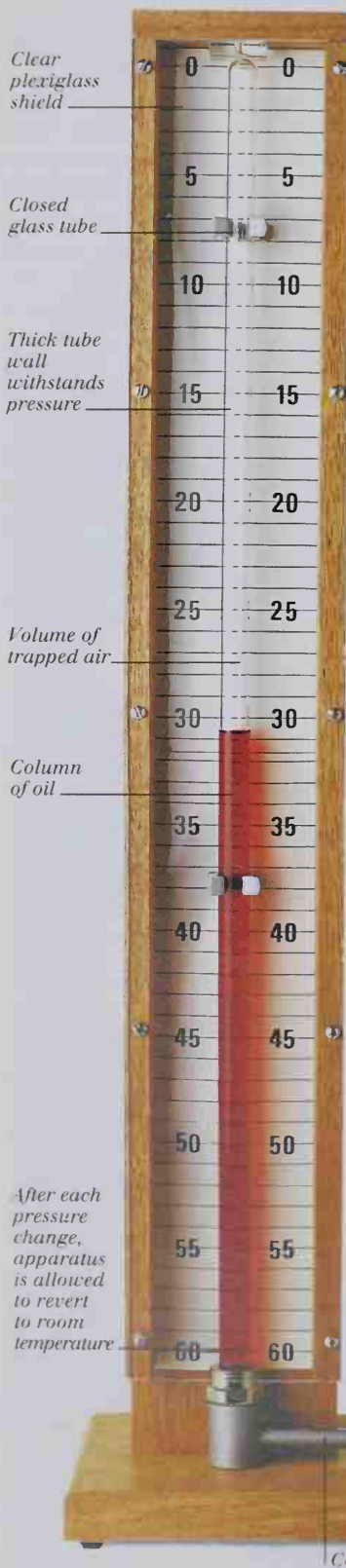

After each pressure change, apparatus is allowed to revert to room temperature

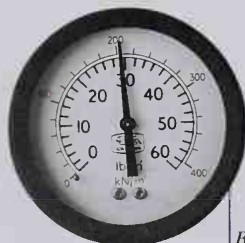

Pressure is measured at various volumes and the results are shown as a graph

Bourdon gauge measures pressure

GRAPH OF PRESSURE AND VOLUME READINGS

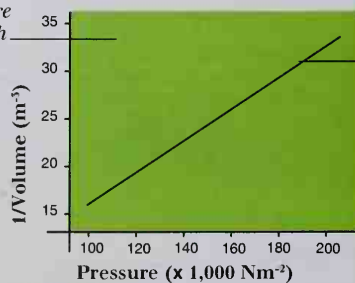

Doubling the pressure halves the volume

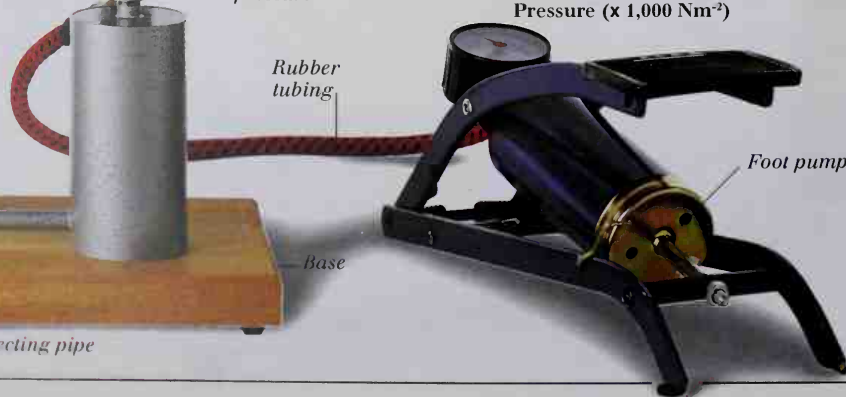

PRESSURE LAW

The pressure exerted by a gas at constant volume increases as the temperature of the gas rises. The apparatus shown is used to verify the Pressure Law. A mass of gas is heated in a water bath, and the pressure of the gas measured. When plotted as points on a graph, the results lie on a straight line.

Doubling the temperature doubles the pressure

GRAPH OF PRESSURE AND TEMPERATURE READINGS

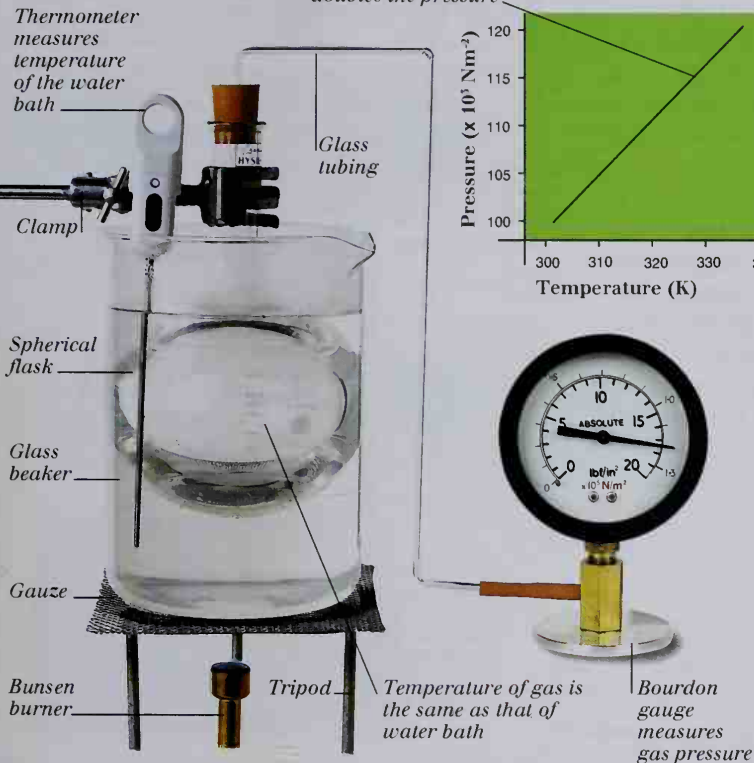
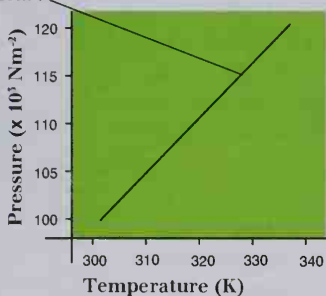

CHARLES' LAW

The volume of a mass of gas at a fixed pressure depends on its temperature. The higher the temperature, the greater the volume. The apparatus shown is used to illustrate Charles' Law. The volume of a gas sample in the glass bulb is noted at various temperatures. A graph shows the results.

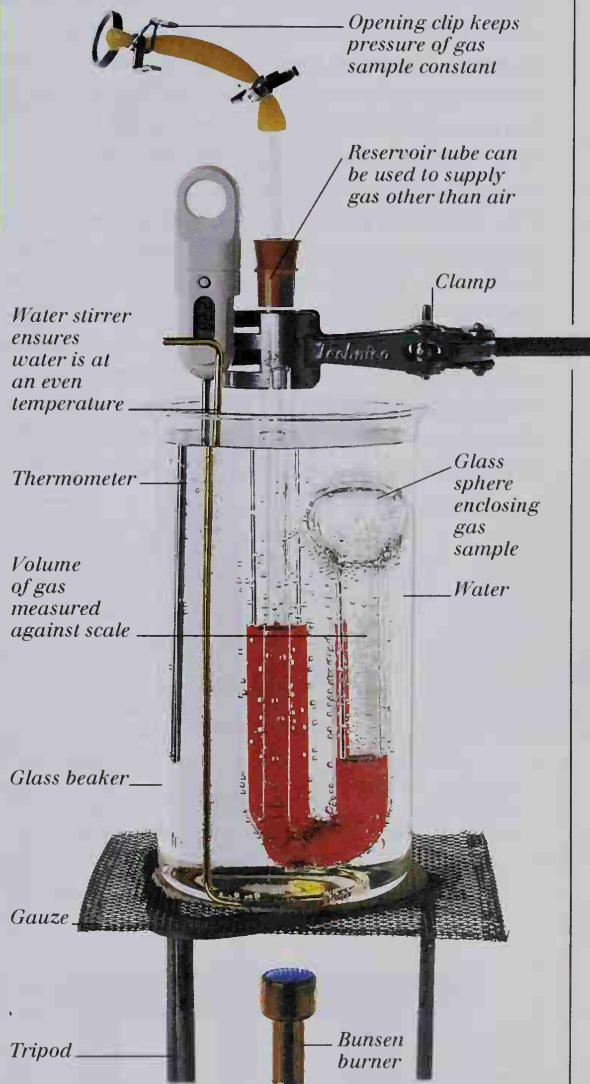

GRAPH OF TEMPERATURE AND VOLUME READINGS

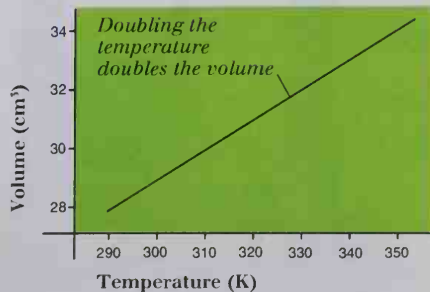

HOT-AIR BALLOON - CHARLES' LAW IN ACTION

The air in the envelope of a hot-air balloon is heated by a gas burner. As its temperature rises, the gas expands in accordance with Charles' Law. The envelope is open at the bottom, so some hot air escapes. Because air has mass (and therefore weight), the balloon weighs less once some air has escaped, although its volume is still large. The pressure of the air outside the envelope produces an upthrust, which (if enough air has been lost from the envelope) will be great enough to lift the balloon.



Electricity and magnetism

ALL ELECTRICAL EFFECTS ARE CAUSED by electric charges. There are two types of electric charges, positive and negative. These charges exert electrostatic forces on each other. An electric field is the region in which these forces have effect. In atoms, protons (see pp. 56-57) carry positive charge, while electrons carry negative charge. Atoms are normally neutral, having equal numbers of each charge, but an atom can gain or lose electrons, for example by being rubbed. It then becomes a charged atom, or ion. Ions can be produced continuously by a Van de Graaff generator. Ions in a charged object may cause another nearby object to become charged. This process is called **induction**. Electricity has many similarities with magnetism (see pp. 44-45). For example, the lines of the electric field between charges (see right) take the same form as lines of magnetic force (see opposite), so magnetic fields are equivalent to electric fields. Iron consists of small magnetized regions called **domains**. If the magnetic directions of the domains in a piece of iron line up, the iron becomes magnetized.

ELECTRIC FIELDS AND FORCES

Charges of the same type repel, while charges of a different type attract. One way to think of an electric field is as a set of lines of force, as illustrated below.

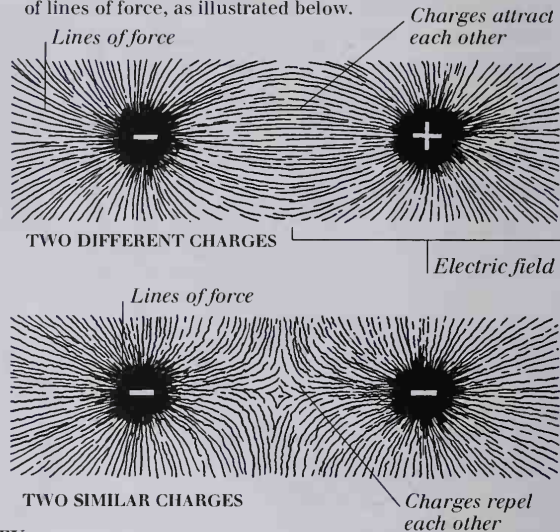

GOLD LEAF ELECTROSCOPE

A polyethylene rod can gain extra electrons when it is rubbed. Touching the charged rod to the top of an electroscope causes electrons to move into the electroscope. The electrons in the central strip and in the gold leaf repel each other, and the leaf lifts.

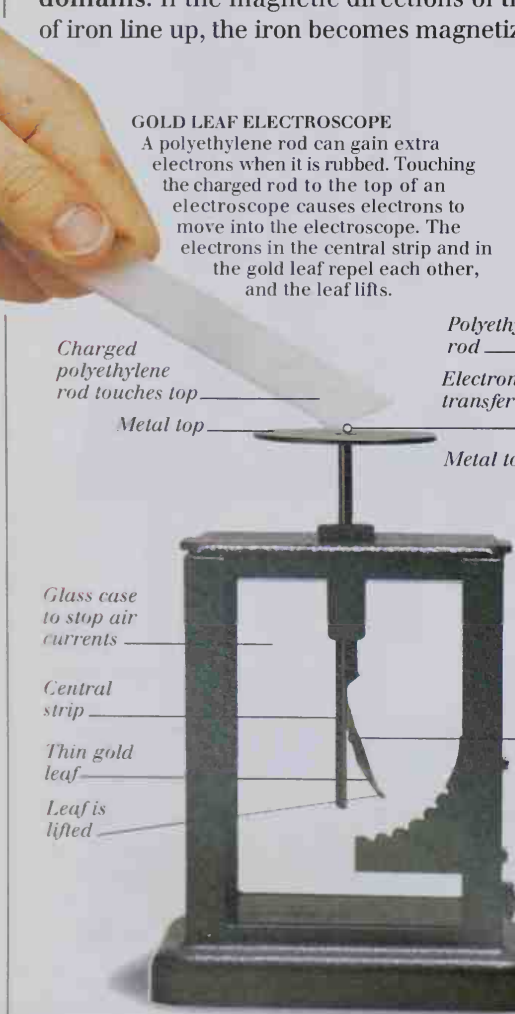

STATIC ELECTRICITY

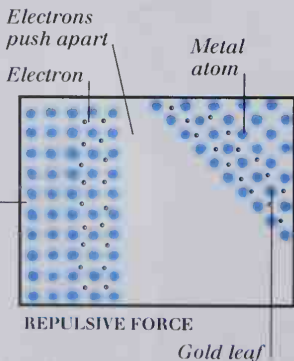
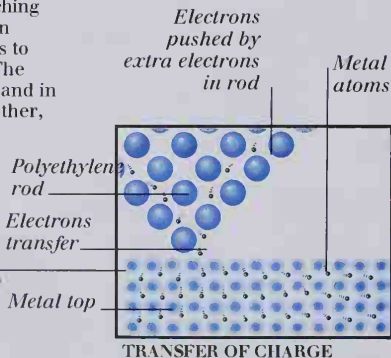

INDUCTION

When a charged object is brought near to other materials, such as paper, electrostatic forces cause a displacement of charge within that material. This is called induction. Negative charges in the paper are displaced, so the edge of the paper nearest the rod becomes positively charged and clings to the negatively charged rod.

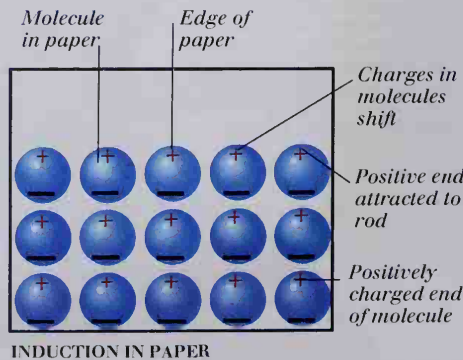
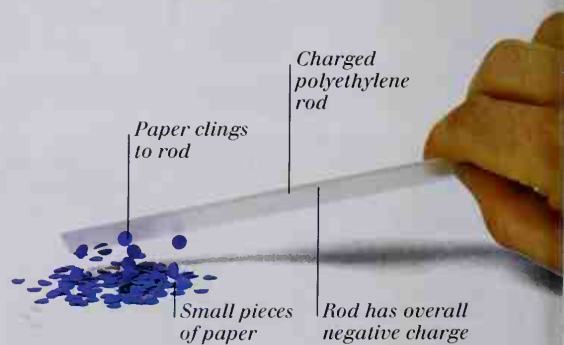

VAN DE GRAAFF GENERATOR

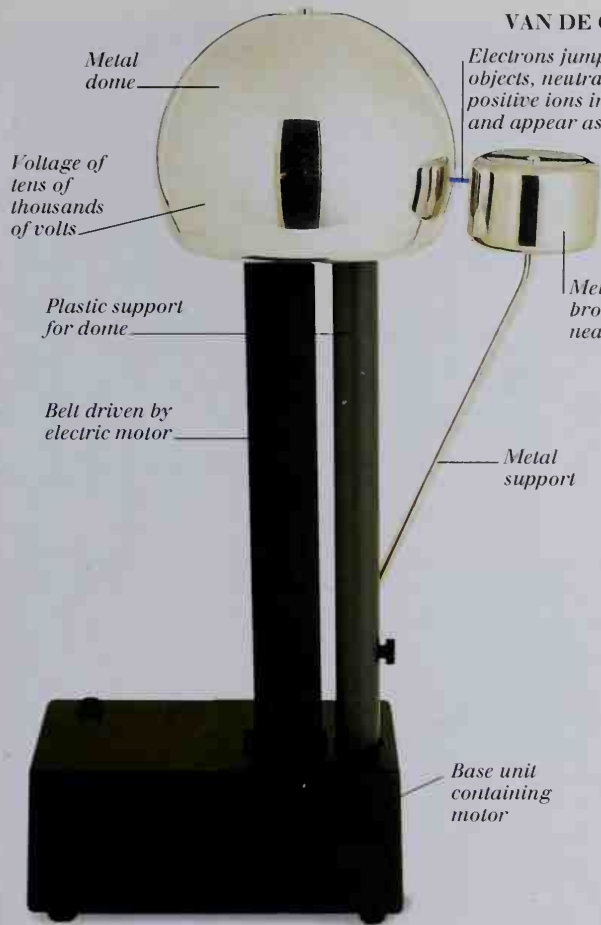

Electrons jump from metal objects, neutralizing positive ions in the dome, and appear as a spark

GENERATION OF IONS

A Van de Graaff generator separates electrons from the atoms of a moving belt. The positive ions created are carried upward by the belt, and take electrons from atoms of a metal dome. The electric field around the dome becomes very strong.

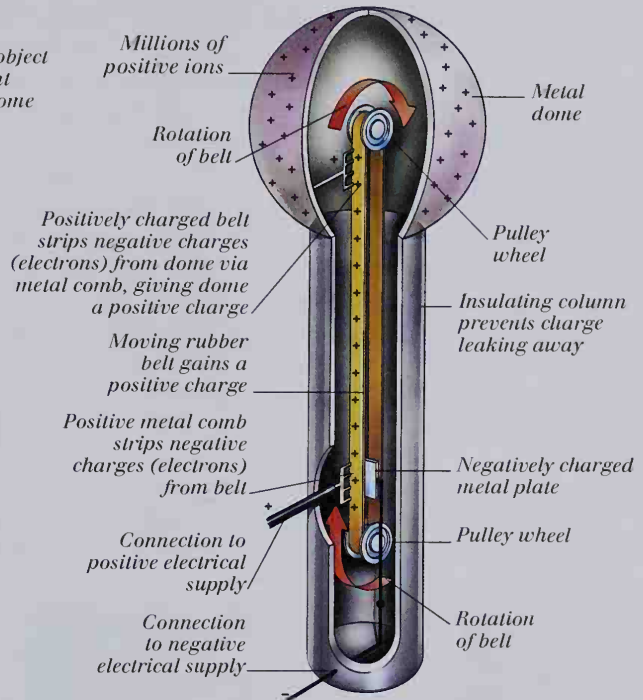

MAGNETISM

MAGNETIC COMPASS

Walkers and sailors use magnetic compasses to find their way. The needle of a compass lines up with the Earth's magnetic field, and always points north-south. The Earth's magnetism is thought to be caused by currents in its molten iron core.

Needle is a small magnet that is free to turn

Needle is suspended in fluid



MAGNETIC FIELDS AND FORCES

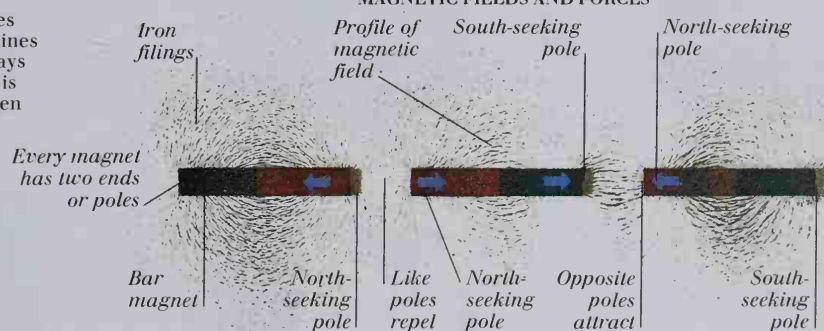

MAGNET DOMAINS

Direction of magnetization within domain is random

Domain
Domain boundary

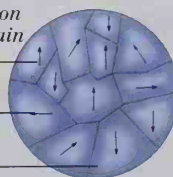

UNMAGNETIZED IRON

Direction of magnetization within domain has aligned

Domain aligned with magnetization has grown

Domain not aligned with magnetization has shrunk

Direction of overall magnetization

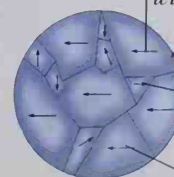

MAGNETIZED IRON

Electric circuits

AN ELECTRIC CIRCUIT IS SIMPLY THE COURSE along which an **electric current** flows. **Electrons** carry negative charge and can be moved around a circuit by **electrostatic forces** (see pp. 40-41). A circuit usually consists of a **conductive material**, such as a metal, where the electrons are held very loosely to their atoms, thus making movement possible. The strength of the electrostatic force is the **voltage** and is measured in volts (V). The resulting movement of electric charge is called an electric current, and is measured in amps (A). The higher the voltage, the greater the current will be. But the current also depends on the thickness, length, temperature, and nature of the material that conducts it. The **resistance** of a material is the extent to which it opposes the flow of electric current, and is measured in ohms (Ω). Good conductors have a low resistance, which means that a small voltage will produce a large current. In batteries, the dissolving of a metal **electrode** causes the freeing of electrons, resulting in their movement to another electrode and the formation of a current.



ELECTRIC CURRENT

Regions of positive or negative charge, such as those at the terminals of a battery, force electrons through a conductor. The electrons move from negative charge toward positive. Originally, current was thought to flow from positive to negative. This is so-called "conventional current."

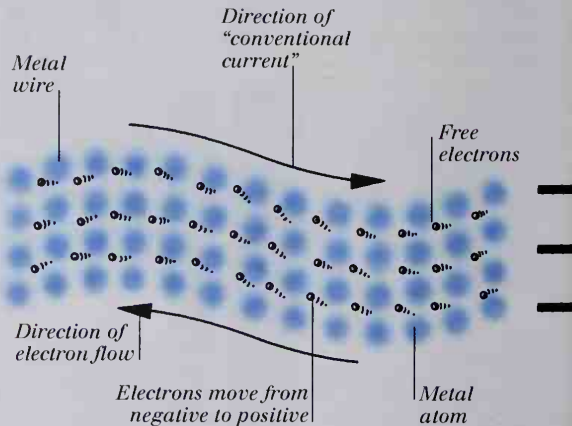

RESISTANCE

OHM'S LAW

A thin wire has a resistance to the flow of current. The longer and thinner the wire, the higher the resistance. An object's resistance can be figured out by dividing the voltage by the current (see p. 578).

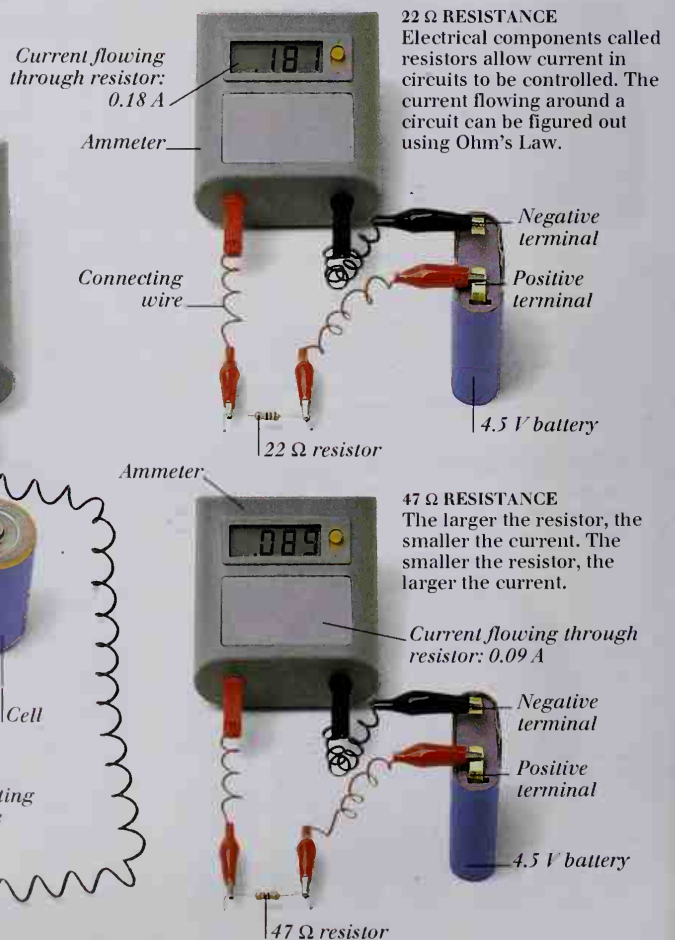
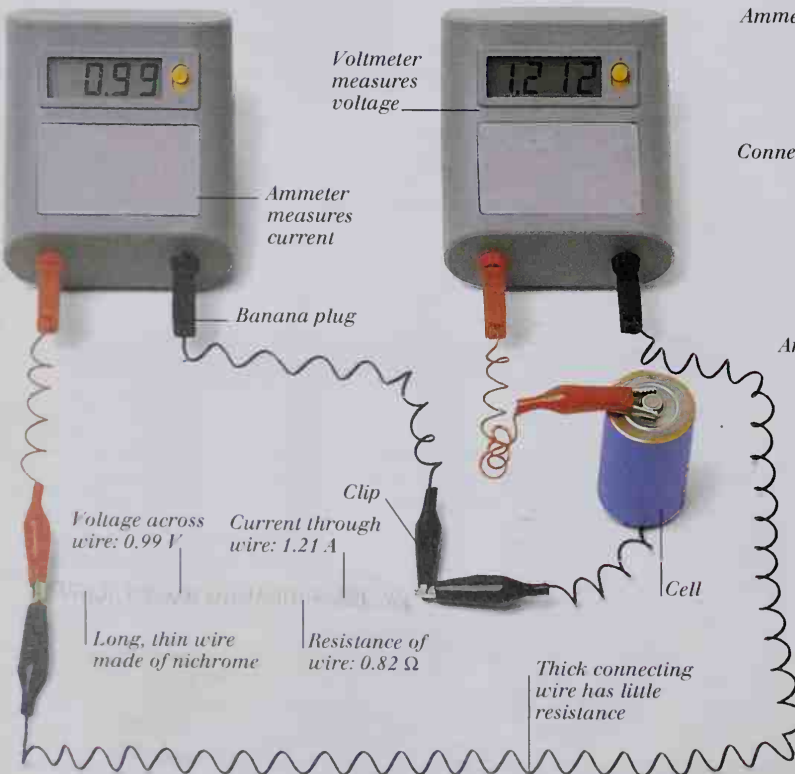

WORKING ELECTRIC CIRCUIT

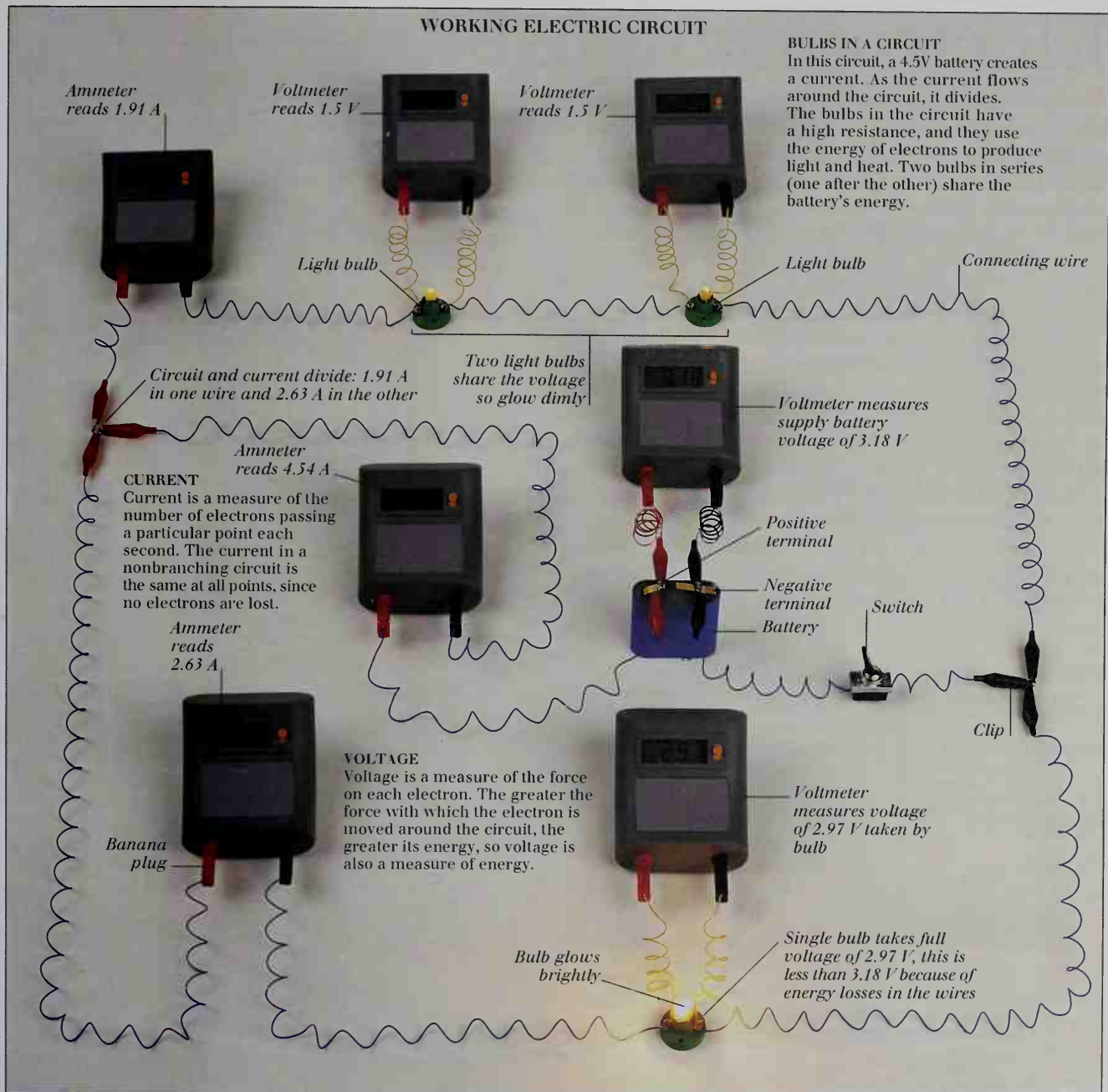

LIGHT BULB

Many electrical components can make use of the energy of moving electrons. They include light bulbs. When current flows through the bulb, a filament inside glows as it gets hot.

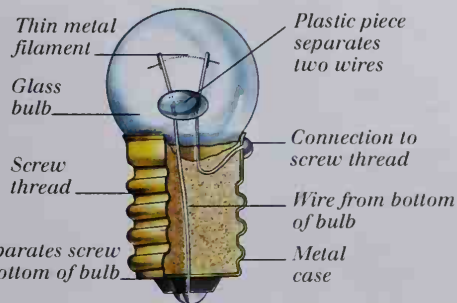

SWITCH

Most circuits include some kind of switch. A switch consists of metal pieces that can be touched together so that a current can flow, or held apart so that it cannot.

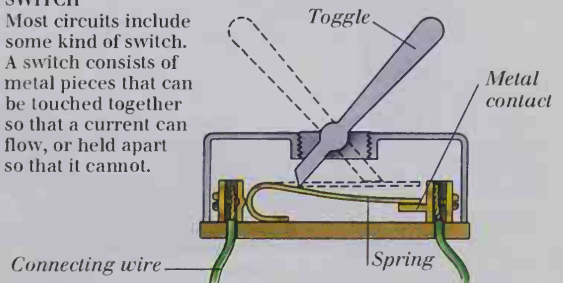

Electromagnetism

ANY ELECTRIC CURRENT WILL PRODUCE magnetism that affects iron filings and a compass needle in the same way as an ordinary, "permanent" magnet. The arrangement of "force lines" around a wire carrying an electric current – its **magnetic field** – is circular. The magnetic effect of electric current is increased by making the current-carrying wire into a coil. When a coil is wrapped around an iron bar, it is called an **electromagnet**. The magnetic field produced by the coil magnetizes the iron bar, strengthening the overall effect. A field like that of a bar magnet (see p. 41) is formed by the magnetic fields of the wires in the coil. The strength of the magnetism produced depends on the number of coils and the size of the current flowing in the wires. A huge number of machines and appliances exploit the connection between electricity and magnetism, including electric motors. Electromagnetic coils and permanent magnets are arranged inside an electric motor so that the forces of electromagnetism create rotation of a central spindle. This principle can be used on a large scale to generate immense forces.

MAGNETIC FIELD AROUND A CURRENT-CARRYING WIRE

The magnetic field produced by a current in a single wire is circular. Here, iron filings sprinkled around a current-carrying wire are made to line up by the magnetic field.

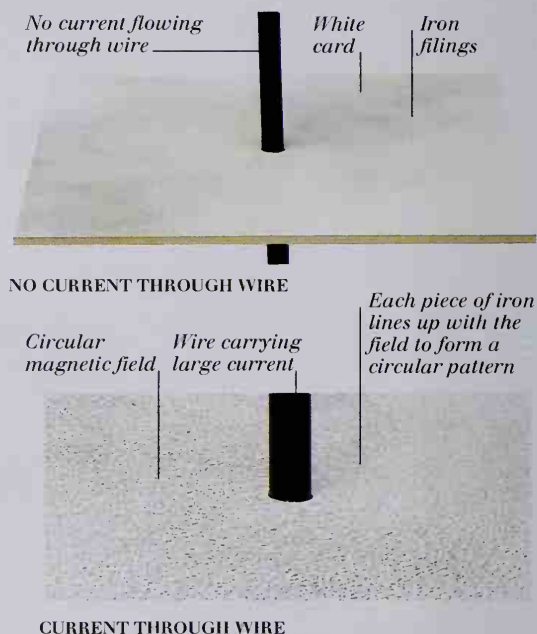

ELECTROMAGNETISM AFFECTING A COMPASS NEEDLE

A compass needle is a small magnet that is free to swivel around. It normally points north-south, in line with the Earth's magnetic field. But when a current flows in an adjacent wire, the needle swings around to line up with the field created by the current.

NO CURRENT, NO MAGNETIC FIELD

Ammeter shows that there is no current flowing in circuit

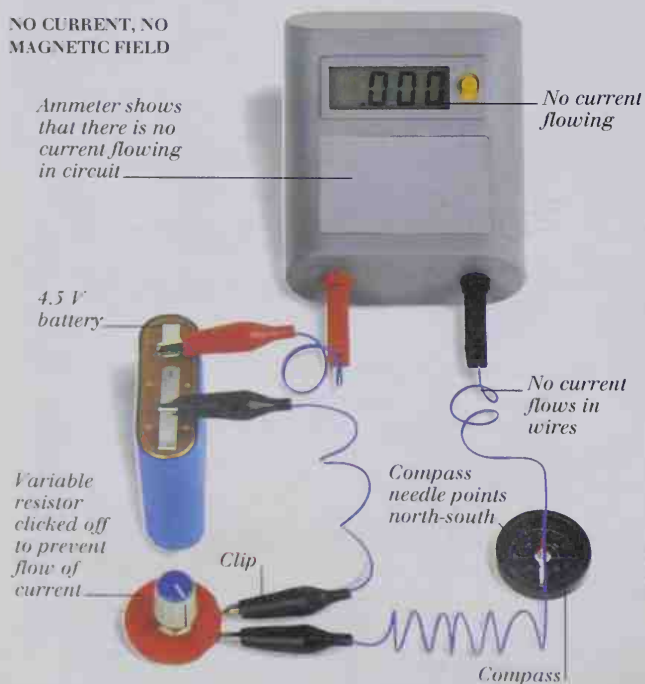

CURRENT FLOWING, MAGNETIC FIELD PRODUCED

Ammeter shows that current is flowing

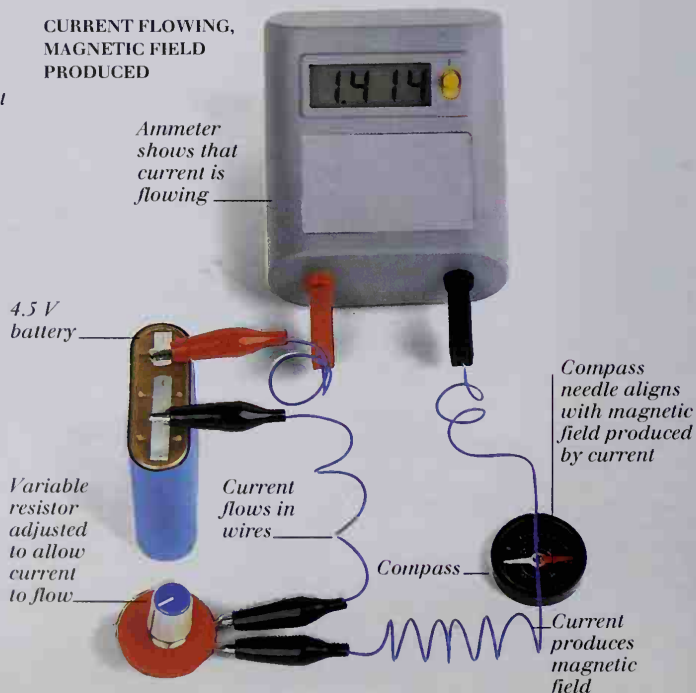

ELECTROMAGNETS

THE STRENGTH OF AN ELECTROMAGNET

An electromagnet is a coil of wire wrapped around an iron bar. It behaves like a permanent magnet, except that it can be turned off. Here, the size of the magnetic force produced by an electromagnet is measured by the number of paper clips it can lift. The strength of an electromagnet depends on the number of turns in the coil and the current flowing through the wire.

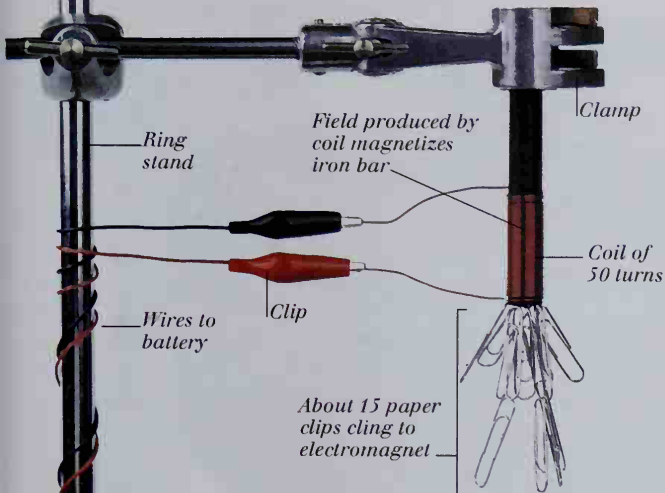

SCRAPYARD ELECTROMAGNET

An electromagnetic crane picks up scrap metal using a powerful electromagnet. The electromagnet is switched on, scrap metal containing iron clings to it, and can be moved around. The metal is dropped by switching the magnet off.

A SOLENOID

The magnetic field around a coil of current-carrying wire resembles that around an ordinary bar magnet. The fields of each individual wire add up to give the overall pattern. A coil like this, with no iron bar at its core, is called a solenoid.

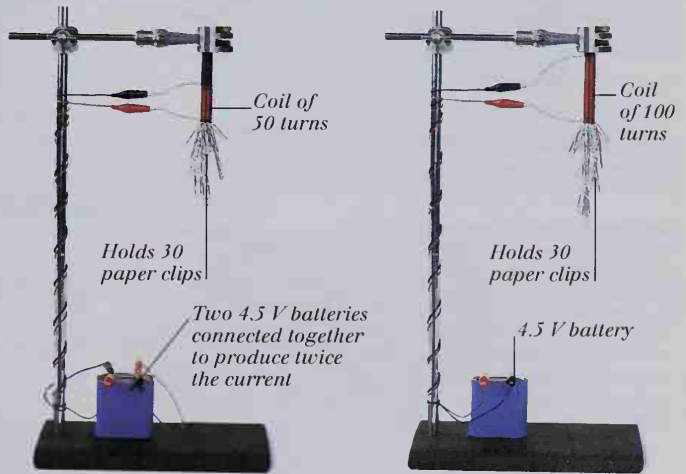
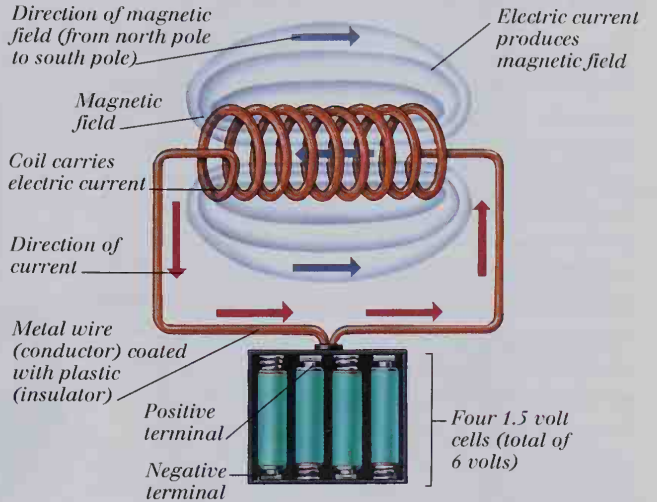

EFFECT OF DOUBLING CURRENT

EFFECT OF DOUBLING NUMBER OF TURNS ON COIL

ELECTRIC MOTORS

Inside the motor, an electric current is sent through a series of wire coils one by one, providing a magnetic field around each coil, one after the other. The magnetism of the coils interacts with the magnetic fields of permanent magnets placed around them. The push and pull of this interaction turns the motor. As the rotor turns, a new coil is activated and the motion continues.

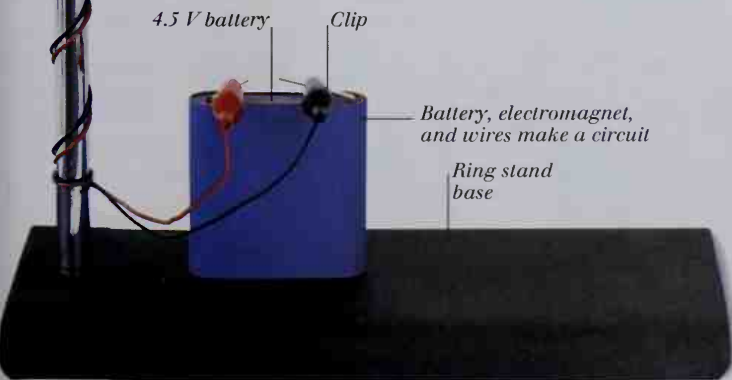
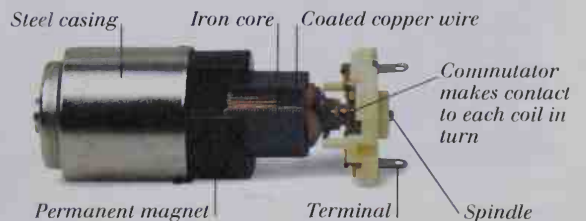

Generating electricity

THERE ARE MANY WAYS TO GENERATE electricity. The most common is to use coils of wire and magnets in a **generator**. Whenever a wire and magnet are moved relative to each other, a **voltage** is produced. In a generator, the wire is wound into a coil. The more turns in the coil and the faster the coil moves, the greater the voltage. The coils or magnets spin around at high speed, turned by water pressure, the wind, or, most commonly, by steam pressure. The steam is usually generated by burning coal or oil, a process that creates pollution. Renewable sources of electricity – such as hydroelectric power, wind power, solar energy, and geothermal power – produce only heat as pollution. In a generator, the **kinetic energy** of a spinning object is converted into electrical energy. A solar cell converts the energy of sunlight directly into electrical energy, using layers of **semiconductors**.

GENERATOR

Inside a generator, you will find coils of wire and magnets (or electromagnets). In the generator shown below, electromagnets spin rapidly inside stationary coils of wire. A voltage is then produced in the coils.

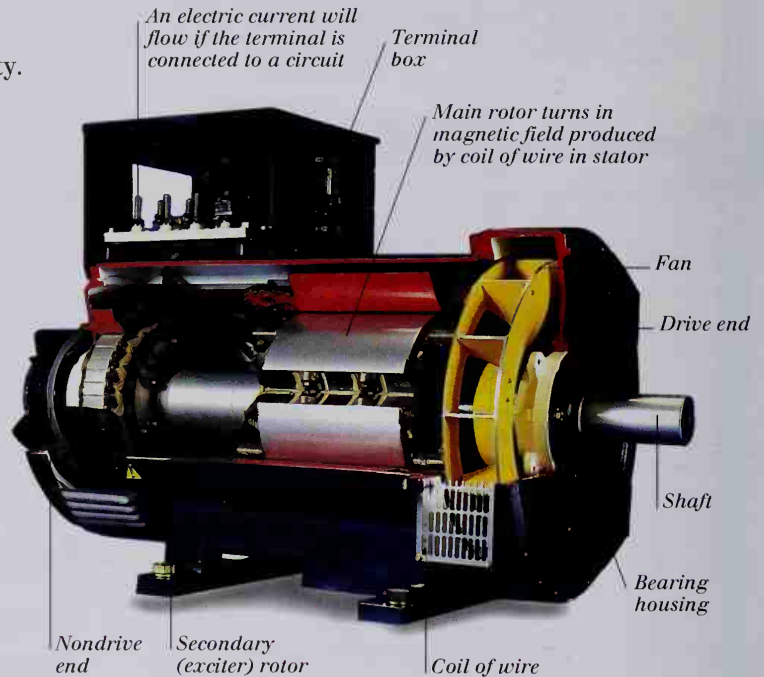

HYDROELECTRIC POWER STATION

Water flows into a hydroelectric power station from a reservoir above. The water exerts pressure on **turbines** within the power station. The pressure pushes the water through the turbines, turning them at great speed. The turbine runs a generator, which produces the electricity.

WATER POWER

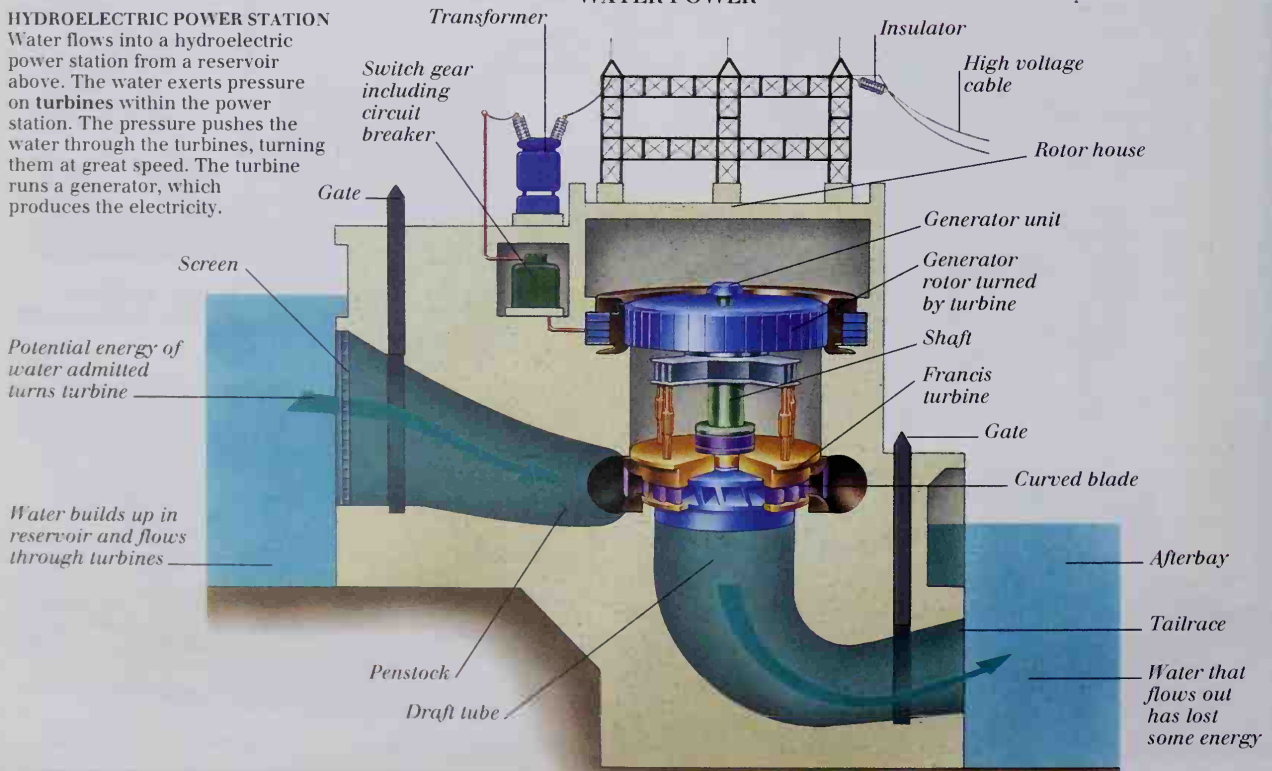

WIND POWER

WIND TURBINE

Energy from the wind is converted to electricity by wind turbines. The rotating turbine blades are connected to a generator, which produces a voltage. The faster the wind blows and the larger the blades, the greater the energy available.

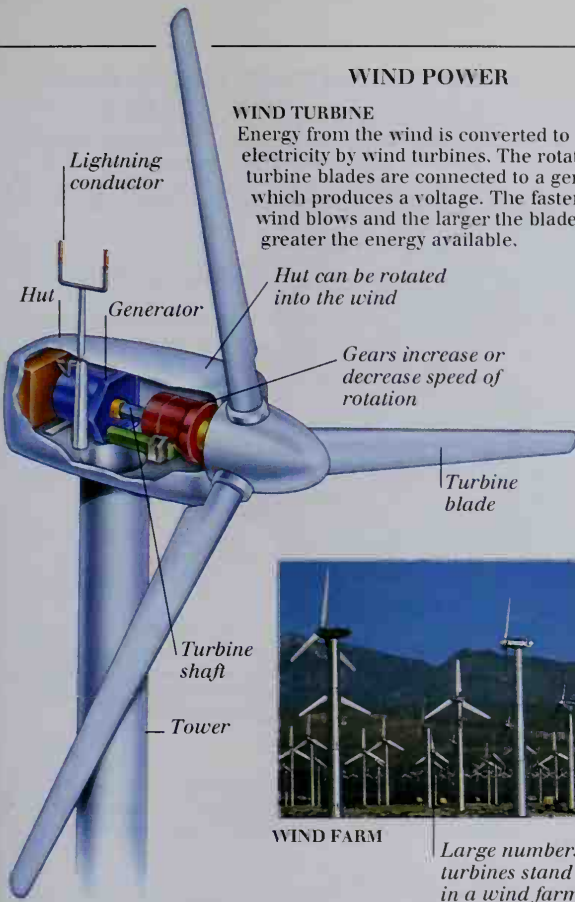

WIND FARM

Large numbers of turbines stand together in a wind farm

OTHER SOURCES

Two further examples of renewable sources are tidal power and geothermal power. The tides are a result of the gravitational pull of the Moon. Geothermal heat is produced by the disintegration of radioactive atoms in the Earth's core.

Excess hot water carried away to heat homes

Steam turns turbine to produce electricity



Steam emerges

Water pumped underground becomes very hot

GEOTHERMAL POWER

Water pumped underground is turned into high-pressure steam by geothermal heat. The steam returns to the surface under pressure and turns turbines.

Tidewater



Barrier

Turbines in barrier turn to produce electricity

TIDAL POWER STATION

Seawater is held back by a barrage as it rises and falls. When there is a difference in height between the water on either side of the barrage, the water escapes through tunnels, turning turbines.

SOLAR ENERGY

The energy of sunlight produces electricity in solar cells by causing electrons to leave the atoms in a semiconductor. Each electron leaves behind a gap, or hole. Other electrons move into the hole, leaving holes in their atoms. This process continues all the way around a circuit. The moving chain of electrons is an electric current.

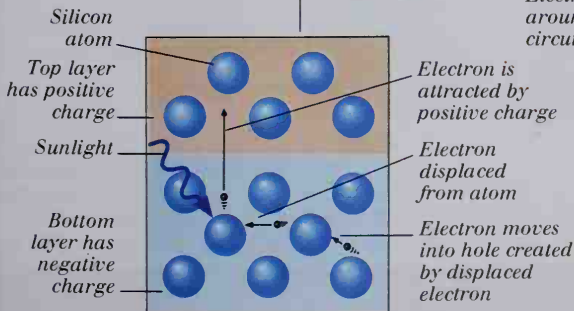
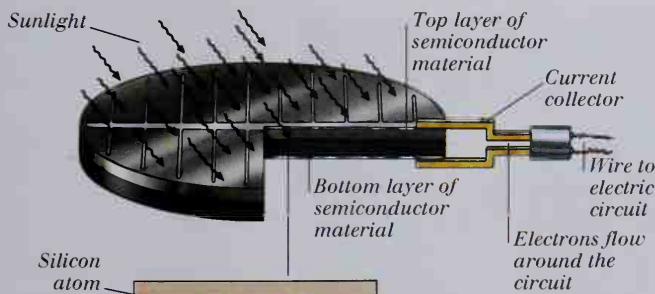

MICROSCOPIC VIEW

Solar cells are usually made of silicon crystals

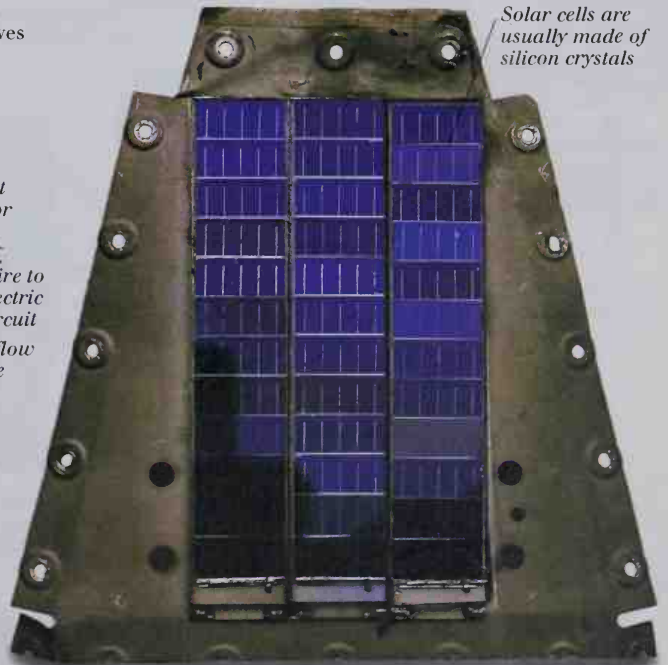

SOLAR CELL

Electromagnetic radiation

ELECTRICITY AND MAGNETISM ARE DIRECTLY related (see pp. 44-47): a changing electric field will produce a changing magnetic field, and vice versa. Whenever an electric charge, such as that carried by an electron, accelerates, it gives out energy in the form of electromagnetic radiation. For example, electrons moving up and down a radio antenna produce a type of radiation known as radio waves. Electromagnetic radiation consists of oscillating electric and magnetic fields. There is a wide range of different types of electromagnetic radiation, called the electromagnetic spectrum, extending from low-energy radio waves to high-energy, short-wavelength gamma rays. This includes visible light and X rays. Electromagnetic radiation can be seen as both a wave motion (see pp. 30-31) or as a stream of particles called photons (see pp. 56-57). Both interpretations are useful, as they each provide a means for predicting the behavior of electromagnetic radiation.

RADIATION AS PARTICLES AND WAVES

OSCILLATING FIELDS

All electromagnetic radiation has behavior typical of waves, such as **diffraction** and **interference**. It can be thought of as a combination of changing electric and magnetic fields.

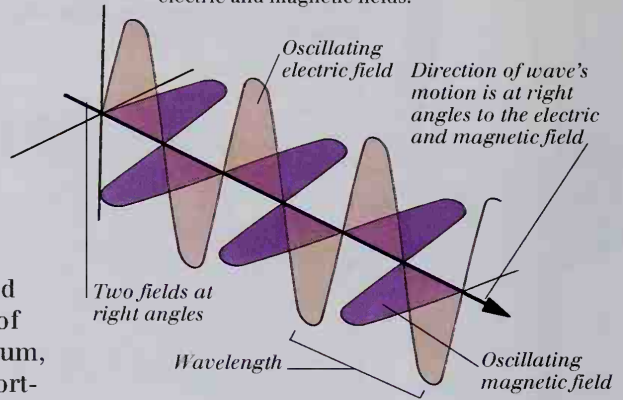

PHOTONS

All electromagnetic radiation also has behavior typical of particles. For example, its energy comes in individual bundles called photons.

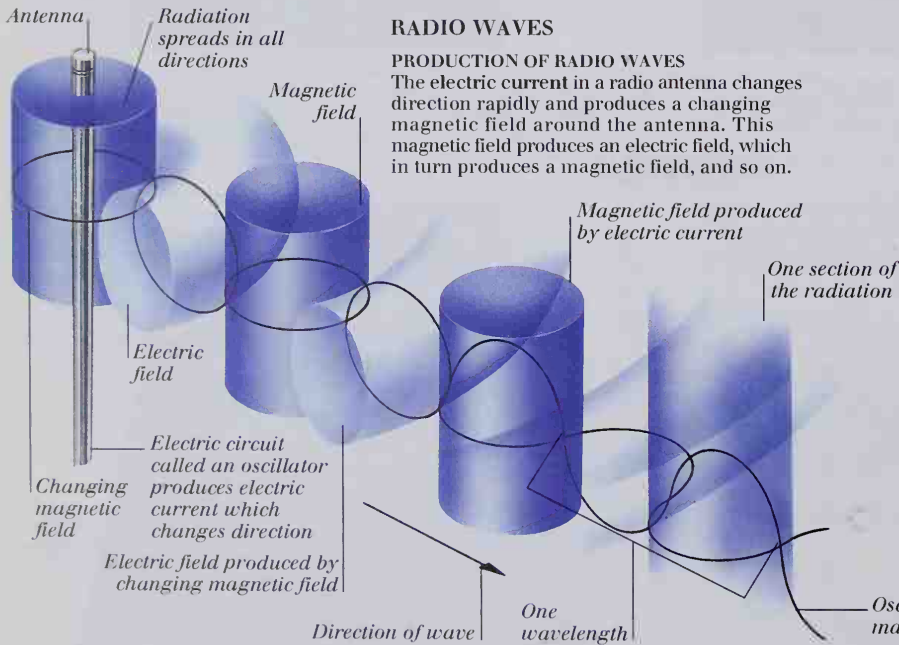

RADIO WAVES

PRODUCTION OF RADIO WAVES
The electric current in a radio antenna changes direction rapidly and produces a changing magnetic field around the antenna. This magnetic field produces an electric field, which in turn produces a magnetic field, and so on.

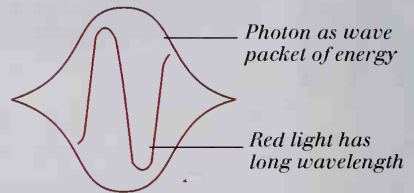

PHOTON OF RED LIGHT

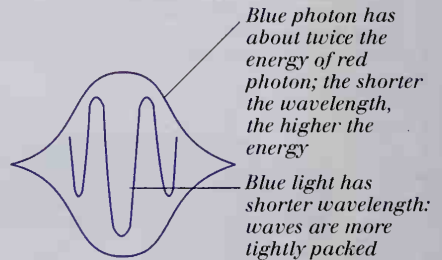

PHOTON OF BLUE LIGHT

THE ELECTROMAGNETIC SPECTRUM

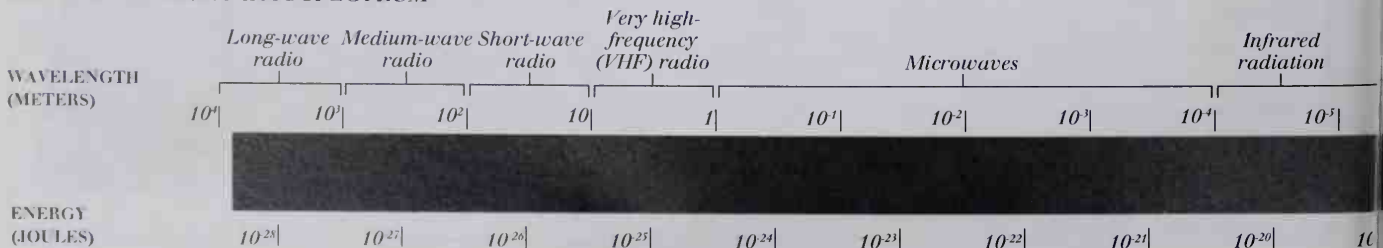

THE WHITE LIGHT SPECTRUM

Human eyes can detect a range of wavelengths of electromagnetic radiation, from "red light" to "blue light." When all of the wavelengths within that range are perceived together, they produce the sensation of white light.

Glass prism

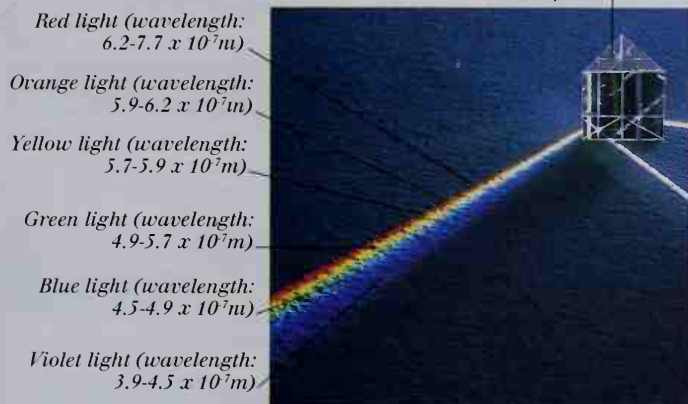

X RAYS

PRODUCTION OF X RAYS

Near the high-energy end of the electromagnetic spectrum come X rays. In an X-ray tube, electrons are accelerated by a strong electric field. They then hit a metal target, and their kinetic energy is turned into electromagnetic radiation.

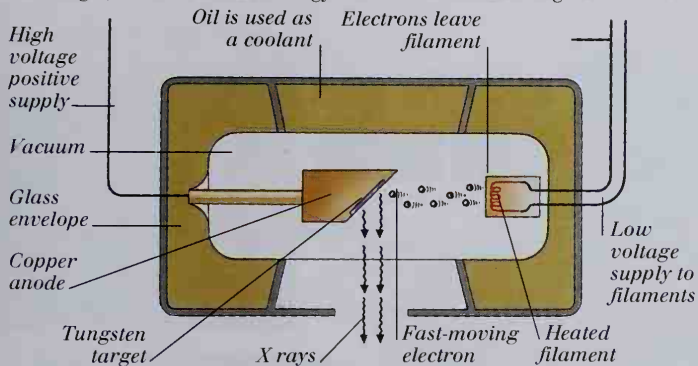

X-RAY PHOTOGRAPH

The main use for X rays is in medical photography. Radiation from an X-ray tube does not pass through bone, so when an image is recorded on paper sensitive to X rays, an image of the bone remains. Thus fractures can be investigated without the need for surgery.

Bones can be examined for fractures without the need for surgery



Image of bone

RADIATION FROM HOT OBJECTS

The atoms of a solid vibrate (see pp. 32-33). Atoms contain electric charges in the form of protons and electrons. Because they vibrate, these charges produce a range of electromagnetic radiation. The rate of vibration – and therefore the wavelengths of radiation produced – depends on temperature, as this steel bar shows.

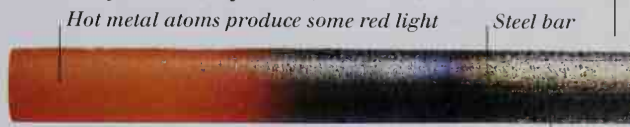

OBJECT HEATED TO ABOUT 900K (627°C)
At 900K, objects give out a range of radiation, mainly infrared. The graph shows how much of each wavelength is radiated.

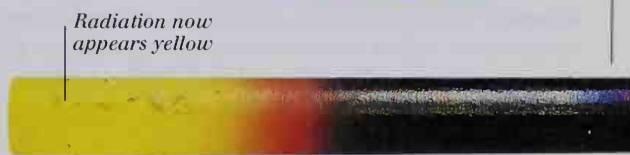
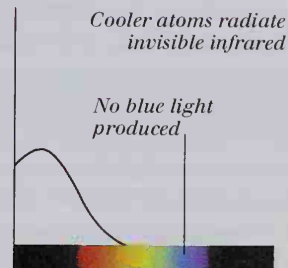

OBJECT HEATED TO ABOUT 1,500K (1,227°C)
As the metal atoms vibrate more vigorously, the radiation has more energy. It therefore includes more of the visible spectrum.

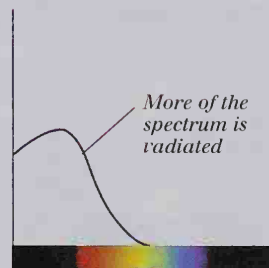

OBJECT HEATED TO ABOUT 1,800K (1,527°C)
Near its melting point, the bar produces even more light. The range of light now includes the entire visible spectrum. This is why it looks bright white.

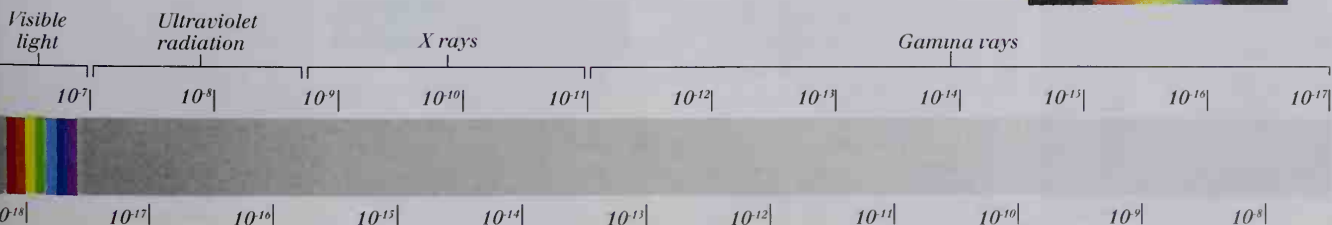
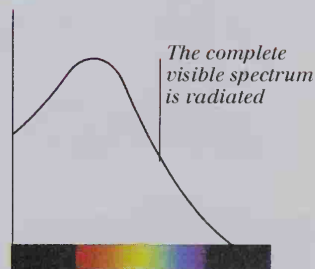

Color

THE HUMAN EYE CAN PERCEIVE ONLY a small section of the electromagnetic spectrum (see pp. 48-49). We call this section "visible light." Different colors across the spectrum of visible light correspond to different wavelengths of light. Our eyes contain cells called cones, which are sensitive to these different wavelengths and allow us to see in color. Three different types of cones are affected by light in the red, green, and blue parts of the spectrum. These correspond to the **primary colors**. Different light sources give out different parts of the spectrum, which appear as different colors. When combined, colored lights appear as different colors. This is called the **additive process**. Adding primary light sources in the correct proportions can produce the sensation of other colors in our eyes. When light hits a **pigment** in an object, only some colors are reflected. Which colors are **reflected** and which **absorbed** depends on the pigment. This is the **subtractive process**. Looking at a colored object in colored light may make it appear different. This is because pigments can only reflect colors that are present in the incoming light.

CONE SENSITIVITY

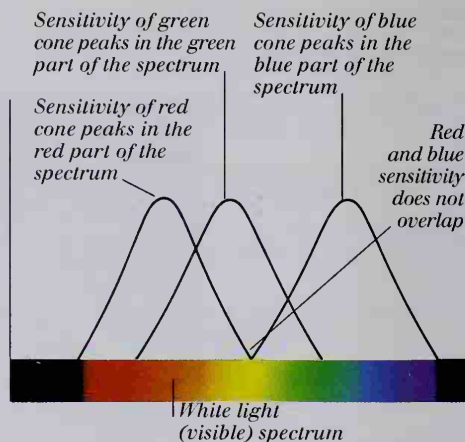

COLOR VISION

There are three different types of cone in the normal human eye, each sensitive to a different part of the spectrum. White light stimulates all three types of cone cells.

SOURCES OF LIGHT



This spectrum shows which colors are produced



All colors of light together combine to produce white

BRIGHT FILAMENT LAMP
With a high electric current, the whole spectrum of visible light is produced (see p. 49).

LED produces colors in the green part of the spectrum



LED appears green

GREEN LED
An LED (light-emitting diode) is made of a semiconductor, and produces certain colors of light.



GREEN LED



Red, yellow, and green light combine to produce orange



Lamp appears orange

No blue light produced

DIM FILAMENT LAMP
With a smaller current, the temperature of the filament (see pp. 42-45) is low.

Two colors of light very close together in the orange part of the spectrum are produced



Lamp appears orange

SODIUM LAMP
In a sodium lamp, an electric current excites electrons in sodium vapor, giving them extra energy. The electrons give the energy out as light.



SODIUM LAMP



Lamp produces certain colors in each part of the spectrum



All three types of cones are stimulated and lamp appears white

FLUORESCENT LAMP
In a fluorescent lamp, chemicals called phosphors produce colors in many parts of the spectrum.

Only certain colors characteristic of neon are produced



Lamp appears orange

NEON TUBE
In a similar way to a sodium lamp, a neon discharge lamp produces a characteristic orange glow.

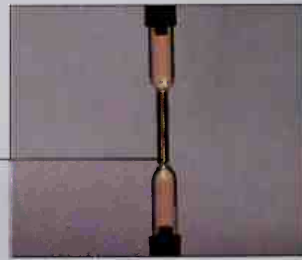

NEON TUBE

ADDITIVE PROCESS

Adding red, green, and blue light in the correct proportions can create the illusion of any other color. These three colors are called primary colors. A color made from adding any two primary colors alone is called a secondary color.

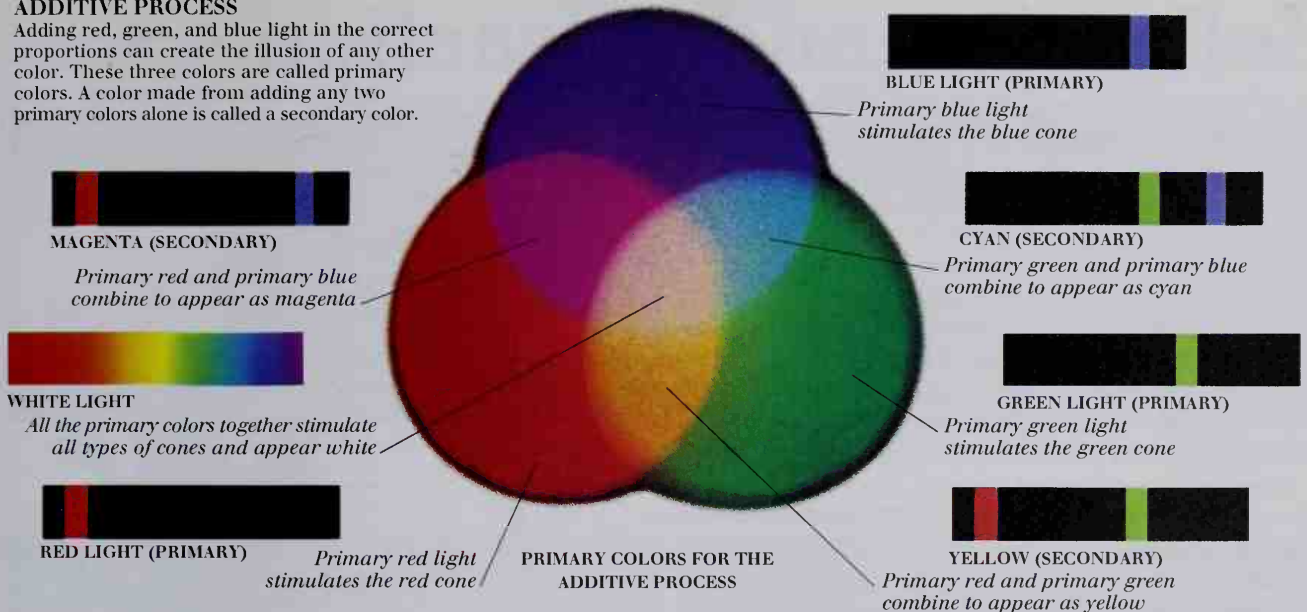

SUBTRACTIVE PROCESS

These three filters contain pigments that absorb some of the colors in the white light passing through them from a light beneath. By mixing primary pigments together, all colors except true white can be produced.

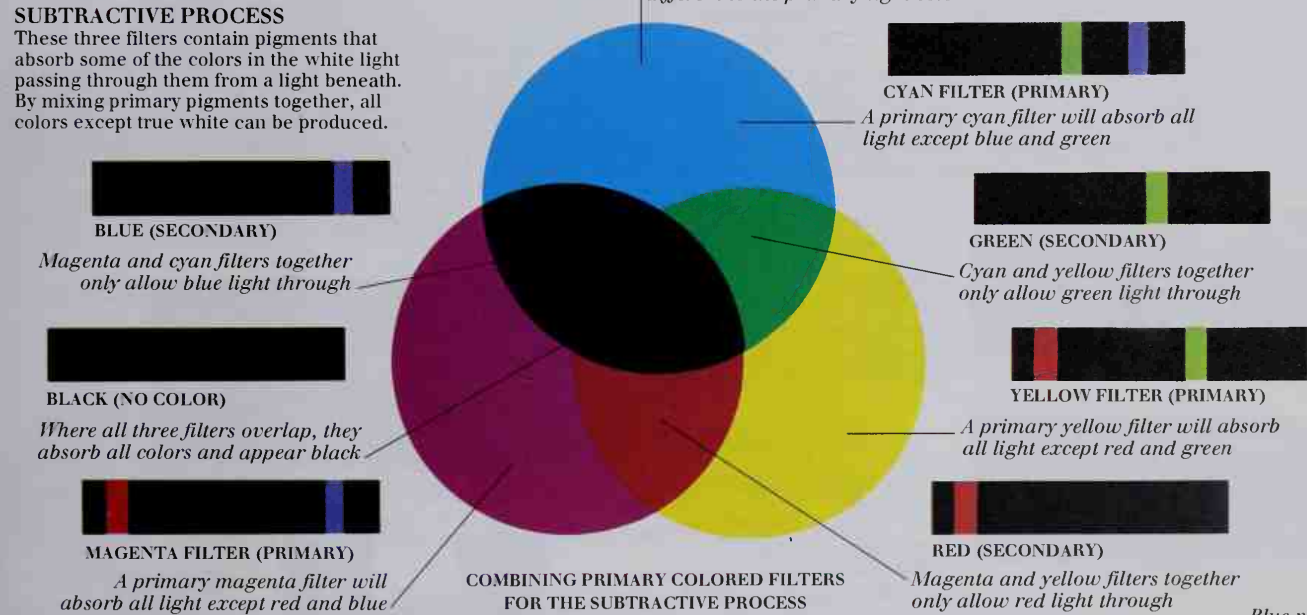

COLORED OBJECTS IN COLORED LIGHT



Reflection and refraction

LIGHT IS A FORM OF electromagnetic radiation (see pp. 48-49). In free space, it travels in a straight line at 300 million meters per second. When a beam of light meets an object, a proportion of the rays may be reflected. Some light may also be absorbed and some transmitted. Without reflection, we would only be able to see objects that give out their own light. Light always reflects from a surface at the same angle at which it strikes it. Thus parallel rays of light meeting a very flat surface will remain parallel when reflected. A beam of light reflecting from an irregular surface will scatter in all directions. Light that passes through an object will be refracted, or bent. The angle of refraction depends on the angle at which the light meets the object, and on the material from which the object is made. Lenses and mirrors can cause light rays to **diverge** or **converge**. When light rays converge, they can reach a point of focus. For this reason, lenses and mirrors can form images. This is useful in binoculars and other optical instruments.

SEEING BY REFLECTED LIGHT

Light travels out from a source and hits objects such as this plant. The plant reflects some of this light, a proportion of which will enter our eyes.

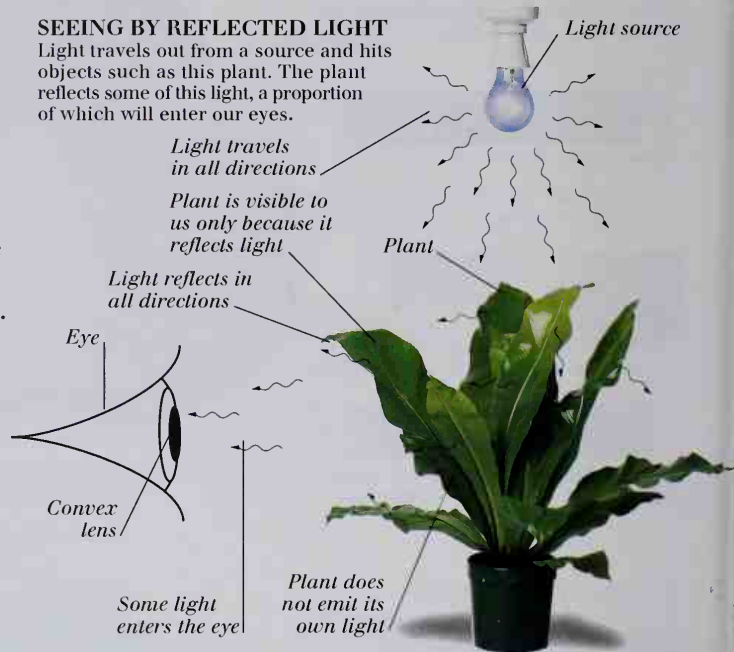

REFLECTING AND REFRACTING

The illustrations below show what happens when parallel beams of light reflect regularly and irregularly and when they refract.

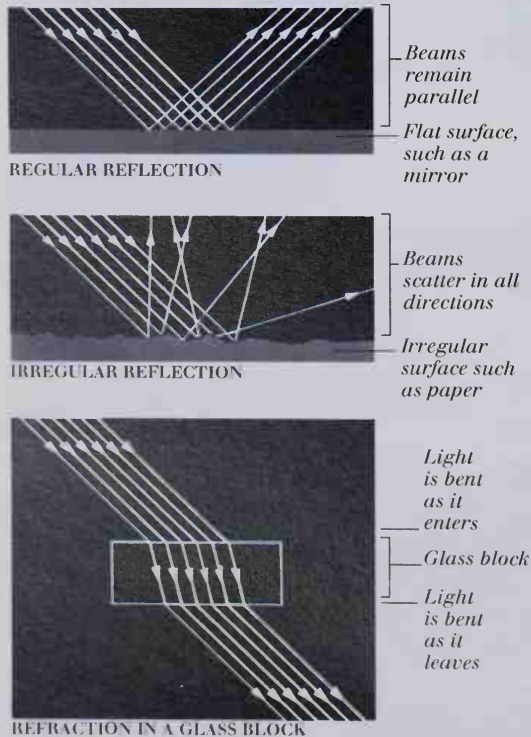

TOTAL INTERNAL REFLECTION

When light moves from one medium to another, for example from glass to air, some of the light will normally be reflected. When the light striking the boundary reaches a certain angle – the **critical angle** – all of the light reflects back. This is called **total internal reflection**. It is put to use in binoculars, where the light path is folded by prisms so that it can be contained within a compact case.

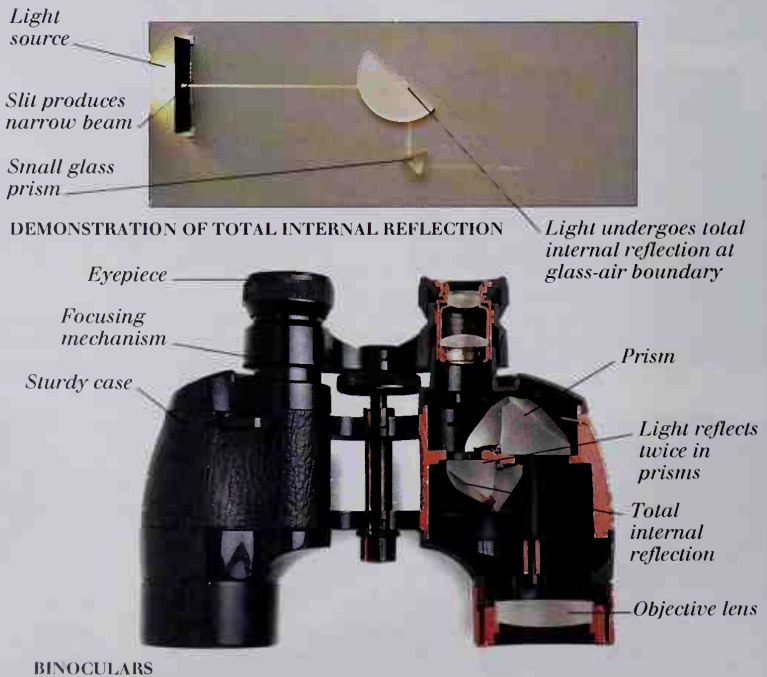

LENSES AND MIRRORS

The images below show how beams of light from a bulb are affected by concave and convex mirrors and lenses. Convex lenses and mirrors

have surfaces that curve outward at the center, while concave lenses curve inward and are thicker at the edges.

CONCAVE LENS (BENDS LIGHT OUTWARD)

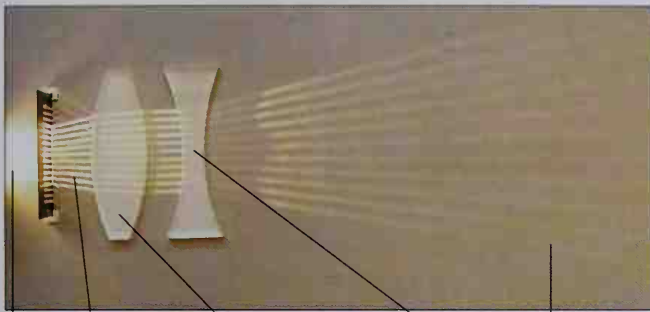

Light source
Light rays travel out in straight lines
Convex lens bends diverging rays into parallel beams
Concave lens
Light rays diverge
Convex mirror

CONVEX LENS (BENDS LIGHT INWARD)

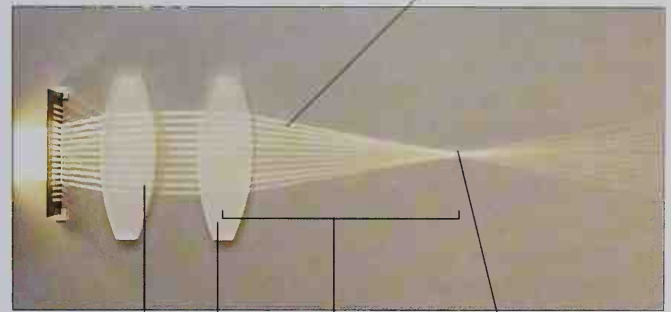

Light rays converge
First convex lens produces parallel beams
Convex lens
Focal length
Light focused to a point
Concave mirror

CONVEX MIRROR (REFLECTS LIGHT OUTWARD)

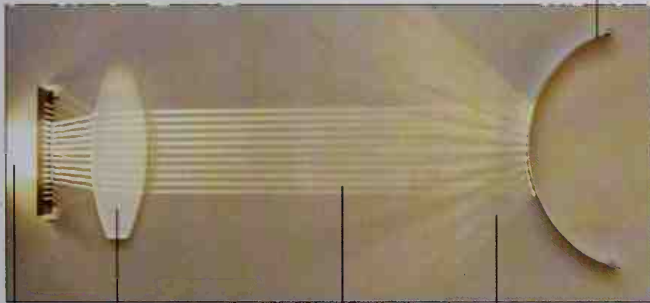

Light source
Convex lens bends diverging rays into parallel beams
Parallel light rays
Light rays diverge as they reflect

CONCAVE MIRROR (REFLECTS LIGHT INWARD)

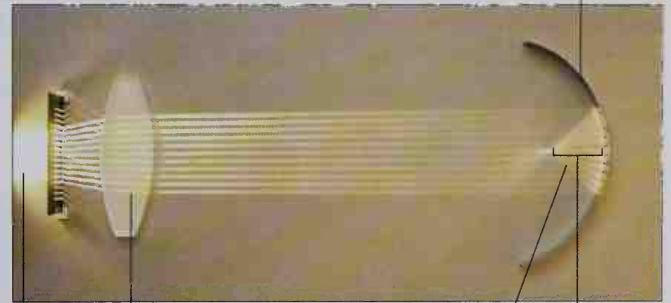

Light source
Convex lens bends diverging rays into parallel beams
Light rays converge as they reflect
Focal length

LENSES

Concave lenses make objects appear smaller, and allow a larger field of vision. Objects lying within the focal length of a convex lens appear larger.

CONCAVE LENS

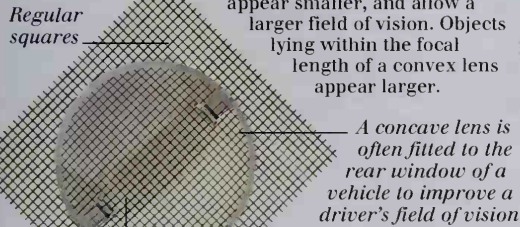

CONVEX LENS

A convex lens can be used as a magnifying glass

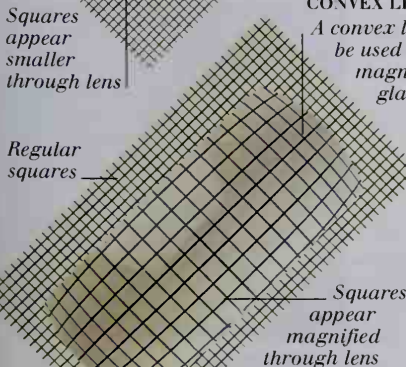
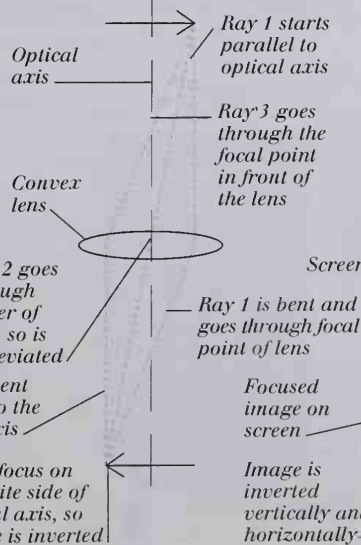

IMAGE FORMATION

Because they focus light, convex lenses can be used to project images onto a screen. The screen must be placed at a point where the rays focus in order for a clear image to be produced. Only objects that lie within a range of distances from the lens, called the **depth of field**, will be in focus at any one time.

IMAGE INVERTS



PROJECTED IMAGE

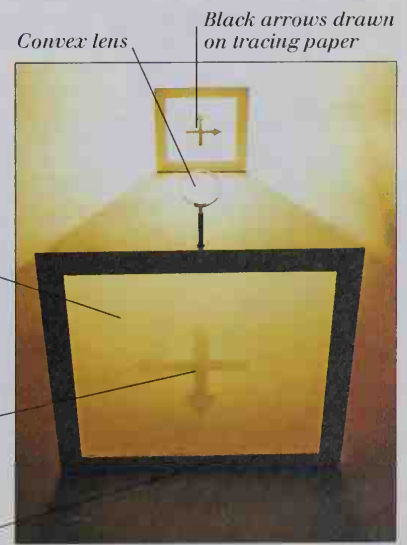

Wave behavior

ALL TYPES OF WAVES CAN COMBINE OR INTERFERE. If two waves are in step so that the peaks coincide, the **interference** results in a wave that will be larger than the original one (**constructive interference**). If the waves are out of step, the peak of one wave will cancel out the trough of another (**destructive interference**). Where the waves are equal in size, they can cancel out entirely. As waves pass around objects or through small openings, they can be **diffracted**, or bent. Diffraction and interference can be observed in water waves, using a ripple tank. The colors seen in soap bubbles are the result of some colors being removed from the white light spectrum by destructive interference. Light is reflected off the front and back surfaces of the film; its interference is dependent upon the wavelength of the light and the thickness of the film. The vibration of a light wave is restricted to one plane by passing the light through a polarizing filter. The resulting "polarized light" has found many applications in the modern world, including in liquid crystal displays (LCDs) and stress analysis.

PRINCIPLE OF SUPERPOSITION

When two waves meet, they add up or interfere, combining their separate values. This is called the **Principle of Superposition** and is common to all types of waves.

CONSTRUCTIVE INTERFERENCE

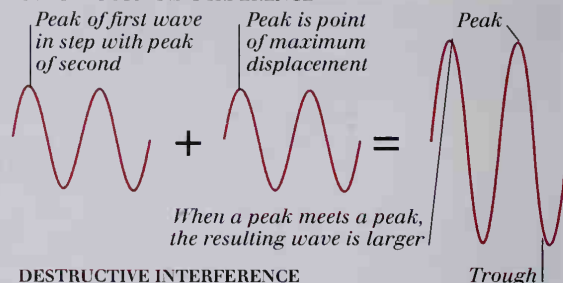

DESTRUCTIVE INTERFERENCE

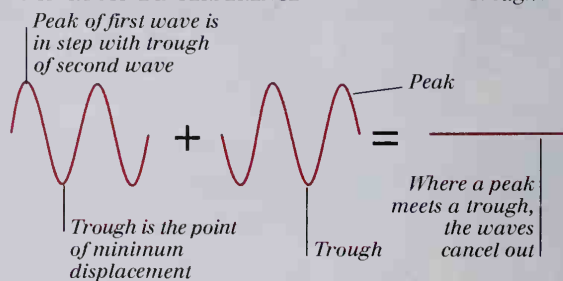

DIFFRACTION AND INTERFERENCE

Waves radiate in semicircles in water

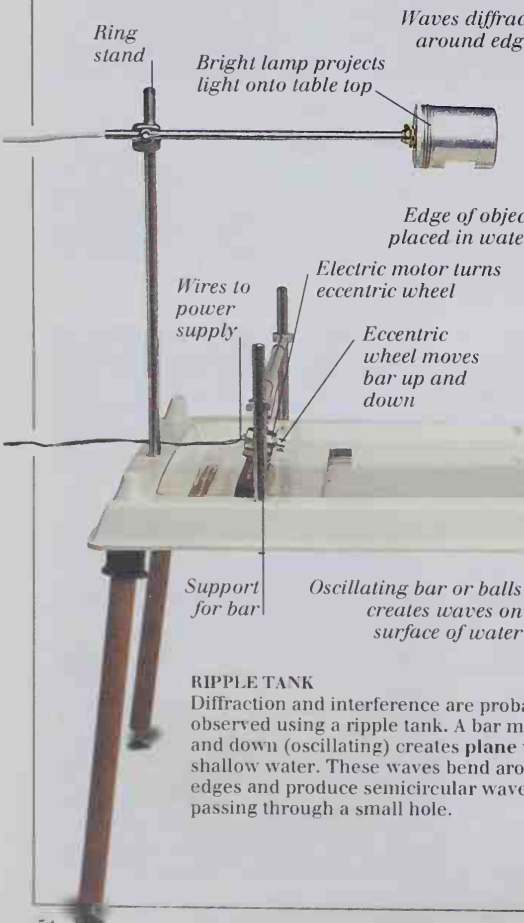

EDGE DIFFRACTION

Small hole in barrier
Plane waves created by bar

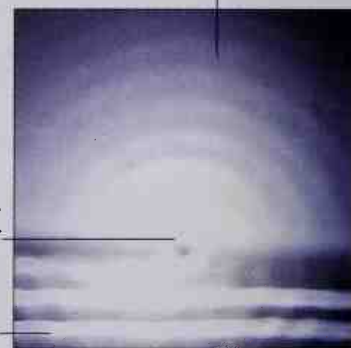

DIFFRACTION THROUGH SMALL HOLE

Waves interfere constructively at this point

Waves interfere destructively at this point

Circular wave travels out in all directions

Circular wave produced by oscillating ball

Oscillating ball

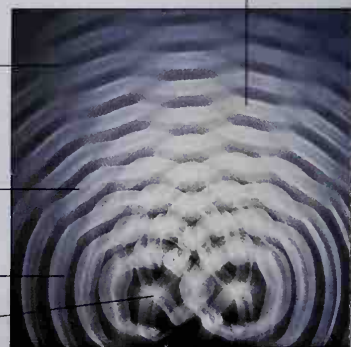

INTERFERENCE

RIPPLE TANK

Diffraction and interference are probably best observed using a ripple tank. A bar moving up and down (oscillating) creates **plane waves** in shallow water. These waves bend around edges and produce semicircular waves after passing through a small hole.

THIN FILM INTERFERENCE

White light reflects off the front and back surfaces of a soap film. The two reflected beams of light interfere. Some wavelengths, and therefore some colors, will be lost from the white light by destructive interference. Which colors are lost depends on the thickness of the film.

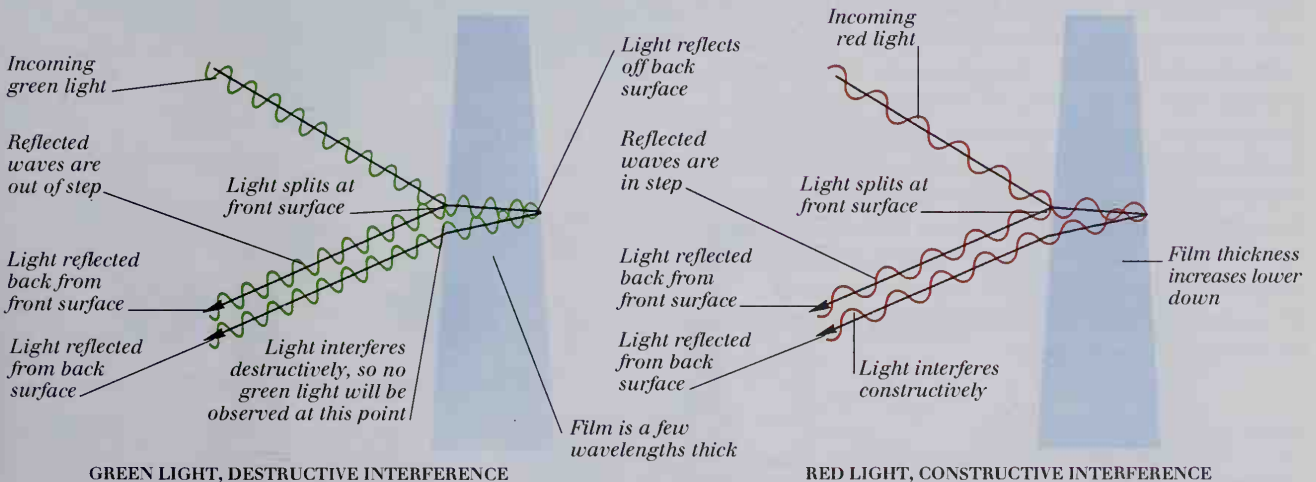

POLARIZATION

Light is a wave motion of vibrating electric and magnetic fields. A polarizing filter only lets through light waves whose electric fields vibrate in one plane. If two polarizing filters are arranged at right angles to each other, no

POLARIZED LIGHT

light at all can pass through. Certain liquid crystals can alter the direction of polarization, which is a process used in liquid crystal displays. Stresses in certain plastics can affect polarized light, and this is the basis of photoelastic stress testing.

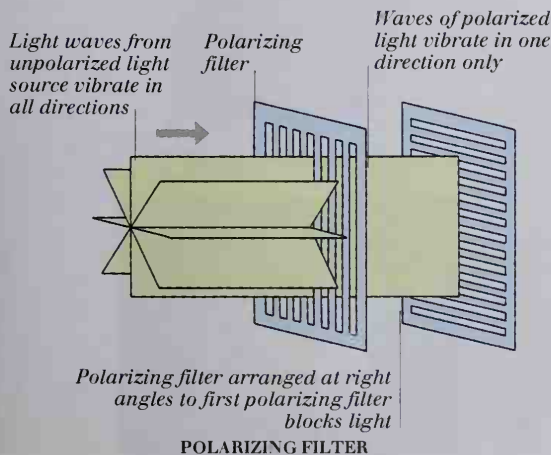

LIQUID CRYSTAL DISPLAY (LCD)

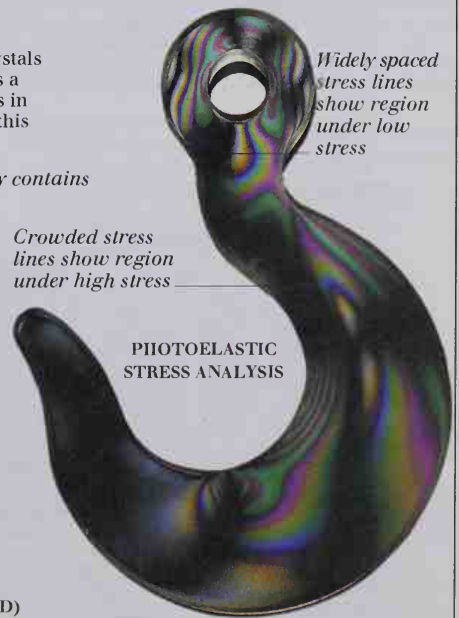

Electrons

ALL ORDINARY MATTER consists of tiny particles called **atoms** (see pp. 72-75). Each atom consists of a positively charged **nucleus** (see pp. 58-59) surrounded by negatively charged **electrons**. Electrons in the atom do not follow definite paths, as planets do, orbiting the Sun. Instead, they are said to be found in regions called **orbitals**. Electrons in orbitals close to the nucleus have less energy than those farther away and are said to be in the first electron shell. Electrons in the second shell have greater energy. Whenever an excited electron releases its energy by falling to a lower shell, the energy is emitted as electromagnetic radiation. When this radiation is visible light, this process is called **luminescence**, and explains "stimulated emission" – the process by which lasers produce light. In one form of luminescence, called **fluorescence**, certain substances glow when illuminated by ultraviolet light. Electrons can be separated from atoms in many ways. In a **cathode ray tube**, a strong electric field tears electrons away from their atoms. Free electrons in the tube are affected by **electric and magnetic fields**. Cathode ray tubes are used in television, where a beam of free electrons forms the picture on the screen.

STIMULATED EMISSION

The word "laser" stands for light amplification by stimulated emission of radiation. Laser light is generated by atoms of a substance known as the lasing medium. One type of laser uses a crystal of ruby as the lasing medium. In such a laser, an intense flash of light excites electrons to a higher energy level. Some of these electrons emit photons of light, which stimulate other excited electrons to do the same, resulting in a kind of chain reaction. The result is an intense beam of light with a precise frequency.

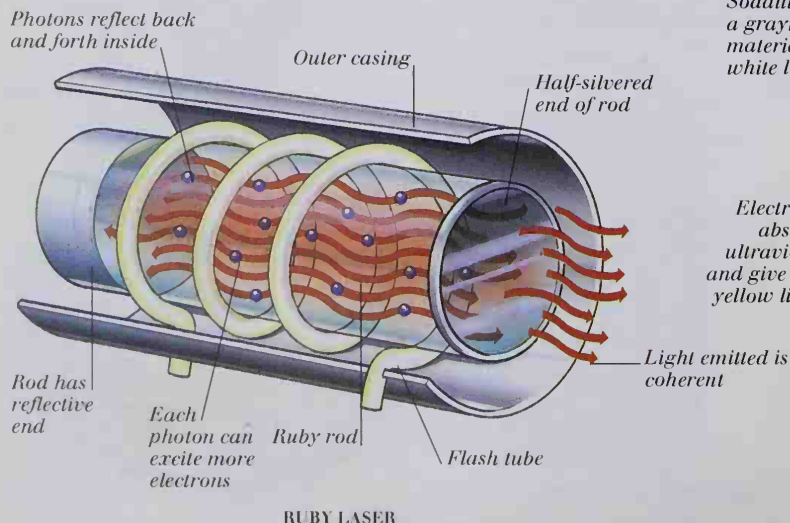

ATOMIC ENERGY LEVELS

When an electron gains energy, it moves to a higher energy level. This is called **excitation**. As excited electrons return to their original level, the extra energy is emitted as a photon of light. This process is called **luminescence**.

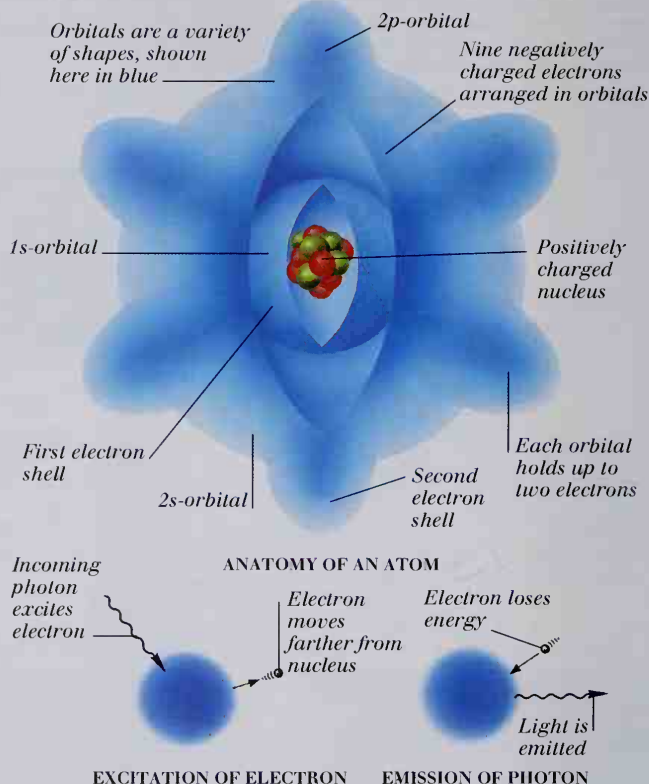

FLUORESCENCE

The mineral **sodalite** produces visible light when illuminated by invisible ultraviolet light. This is an example of a type of luminescence called **fluorescence**. The color of the light emitted depends upon the difference in energy between the energy levels in atoms within the sodalite.

Sodalite is a grayish material in white light

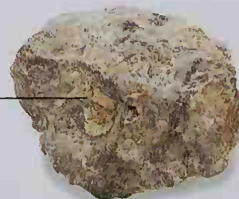

SODALITE IN WHITE LIGHT

Electrons absorb ultraviolet and give out yellow light

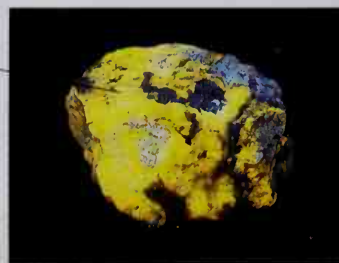

SODALITE IN ULTRAVIOLET LIGHT

CATHODE RAY TUBE

Inside a cathode ray tube, an electric current heats a small filament. The heat generated gives electrons extra energy, moving them farther from their nuclei. A strong electric field then completely removes electrons from their atoms. The free electrons are attracted to the positive anode and pass through it as a cathode ray.

Beam of electrons (cathode ray) made visible by phosphorescent screen

DEFLECTING THE ELECTRONS

Because electrons have electric charge, forces can be applied to them by electric and magnetic fields in the cathode ray tube. The direction of the force depends upon the direction and type of the field.

Screen glows when hit by electrons

*Vacuum
Glass tube
Electrons travel in straight line*

Anode connected to positive supply

Electrons curve in parabolic path due to electric field

*Wire connecting heater and cathode to power supply
Negative terminal*

Wire connecting anode to power supply

STRAIGHT CATHODE RAY IN TUBE

ELECTRON BEAMS

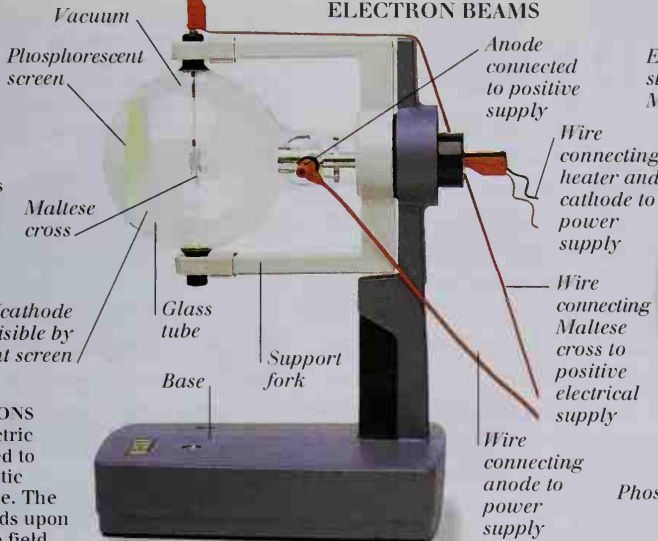

SIDE VIEW

*Electron shadow of Maltese cross
Green glow where electrons hit screen*



FRONT VIEW

Electrons travel in part of a circular path due to magnetic field

Coil produces magnetic field

4.5 V battery

DOWNWARD DEFLECTION BY ELECTRIC FIELD

DOWNWARD DEFLECTION BY MAGNETIC FIELD

HOW A TELEVISION WORKS

DEFLECTED ELECTRON BEAMS

At the heart of most televisions is a cathode ray tube. Electron beams are produced at the back of the tube. Coils of wire around the tube create magnetic fields, which deflect the electron beams to different parts of the screen. The screen itself is coated with phosphorescent materials called phosphors.

Electron beams (cathode rays)

Phosphorescent screen

Picture built up as beams scan across the screen

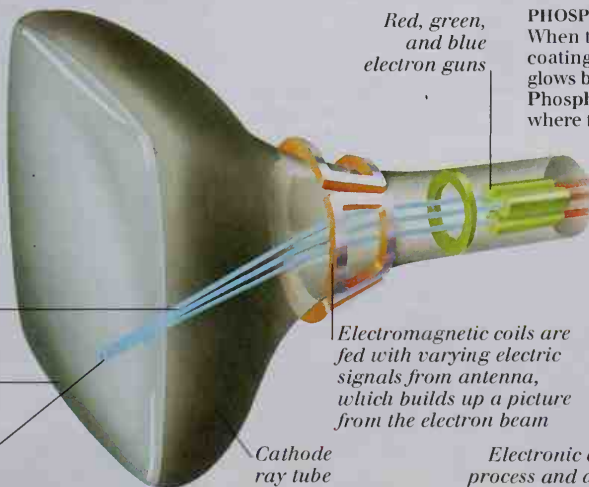

Red, green, and blue electron guns

Electromagnetic coils are fed with varying electric signals from antenna, which builds up a picture from the electron beam

Cathode ray tube

Electronic circuits process and amplify the signal

PHOSPHORESCENCE

When the cathode rays hit the special coating on a television screen, the screen glows because it is phosphorescent. Phosphorescence is a form of luminescence where the incoming energy is not reemitted immediately but is stored and reemitted over a period of time. This means that as the cathode ray quickly scans the picture, the phosphor glows for long enough for a whole picture to form.

Signal received from television antenna consists of a varying electric current

Nuclear physics

AT THE CENTER OF EVERY ATOM LIES a positively charged nucleus. It consists of protons and neutrons. The number of protons in the nucleus is called the atomic number. Because they all have the same electric charge, protons repel each other. The nucleus holds together despite this repulsion because of the strong nuclear force (see pp. 60-61). The balance between the repulsive force and the strong nuclear force determines whether a nucleus is stable or unstable. On the whole, small nuclei are more stable than larger ones, because the strong nuclear force works best over small distances. An unstable, larger nucleus can break up or decay in two main ways, alpha decay and beta decay. These produce alpha and beta particles. In each type of decay, the atomic number of the new nucleus is different from the original nucleus, because the number of protons present alters. Nuclei can also completely split into two smaller fragments, in a process called fission. In another nuclear reaction called fusion, small nuclei join together. Both of these reactions can release huge amounts of energy. Fusion provides most of the Sun's energy, while fission can be used in power stations to produce electricity.

FLUORINE-19 NUCLEUS

The number of protons in a nucleus defines what element the atom is. For example, all fluorine atoms have nine protons. Fluorine has an atomic number of 9. The number of neutrons can vary. Fluorine-19 has ten neutrons, while fluorine-18 has nine.

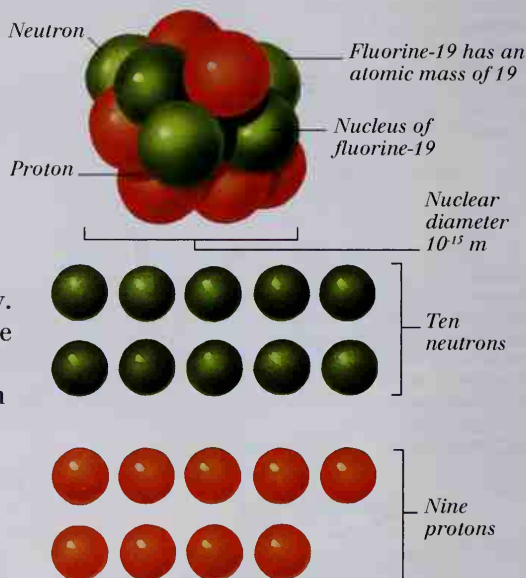

RADIOACTIVITY

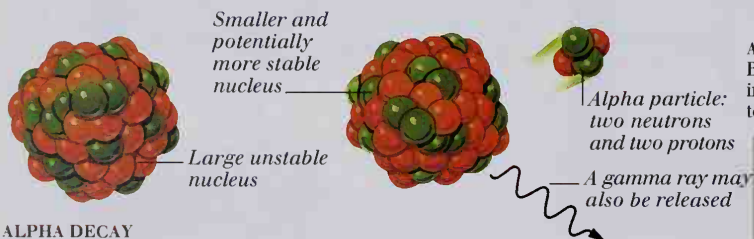

ALPHA DECAY

An unstable nucleus may reduce its size by releasing an alpha particle.

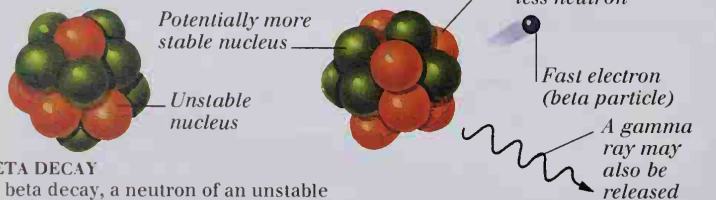

BETA DECAY

In beta decay, a neutron of an unstable nucleus changes into a proton and an electron. The proton remains in the nucleus, while the electron is released at high speed.

ANALYZING RADIOACTIVITY

Because of their electric charges, alpha and beta rays will be deflected into curved paths by a strong magnetic field. Cloud chambers are used to show these paths, as in the illustration below.

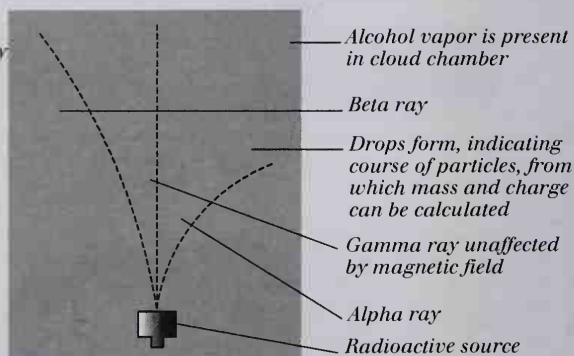

GEIGER-MULLER TUBE

As they pass through the air, alpha and beta rays hit atoms, separating electrons and creating ions, which can be detected inside a Geiger-Müller tube.

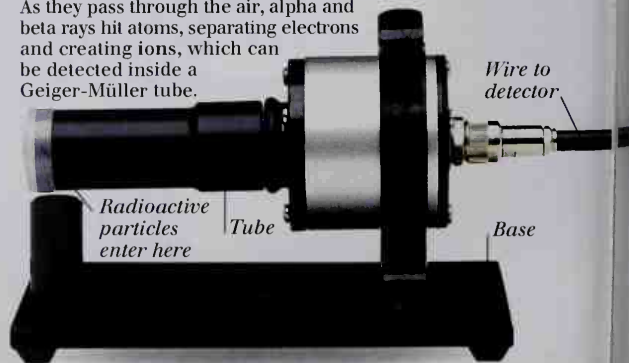

COSMIC RAYS

The Earth is constantly bombarded by particles from space. They are called cosmic rays. Most of them are protons from atoms of the most abundant element, hydrogen. Occasionally, the protons collide with atoms in the air, producing showers of secondary particles called secondary cosmic rays.

Tracks left by cosmic rays in a bubble chamber

NUCLEAR FISSION

A neutron hitting a large, unstable nucleus may split or fission into two smaller, more stable fragments, releasing large amounts of energy. Often, more free neutrons are produced by this fission, and these neutrons can cause other nuclei to split. The process may continue, involving many nuclei in a chain reaction.

Free neutron

Large parent nucleus

Nucleus becomes distorted and begins to split

Fission fragment (daughter nucleus)

Nucleus becomes distorted and begins to split

Fission fragment (daughter nucleus)

Large parent nucleus
Free neutron

Fission releases free neutron

Fission releases large amount of energy

Free neutron

Large amount of energy released

Fission fragment (daughter nucleus)

Fission fragment (daughter nucleus)

Free neutron

Large parent nucleus

NUCLEAR FUSION

Just as large nuclei can split, so some small nuclei can join together, or fuse. Like fission, fusion can release energy. One of the highest energy fusion reactions involves nuclei of hydrogen, which collide at great speed, forming a nucleus of helium.

Nucleus of hydrogen-2

New nucleus of helium-4

Nucleus of hydrogen-3

Neutron ejected from helium nucleus

Nucleus becomes distorted and begins to split

Fission fragment (daughter nucleus)

Rate of fission multiplies as more neutrons are released

Large amount of energy released

Free neutron

Large parent nucleus

Large parent nucleus

NUCLEAR POWER

NUCLEAR POWER STATION

A nuclear chain reaction releases huge amounts of heat. This heat can be used to generate electricity (see pp. 46-47), in a nuclear power station. The reactions occur in the nuclear reactor, and the heat produced is used to make steam.

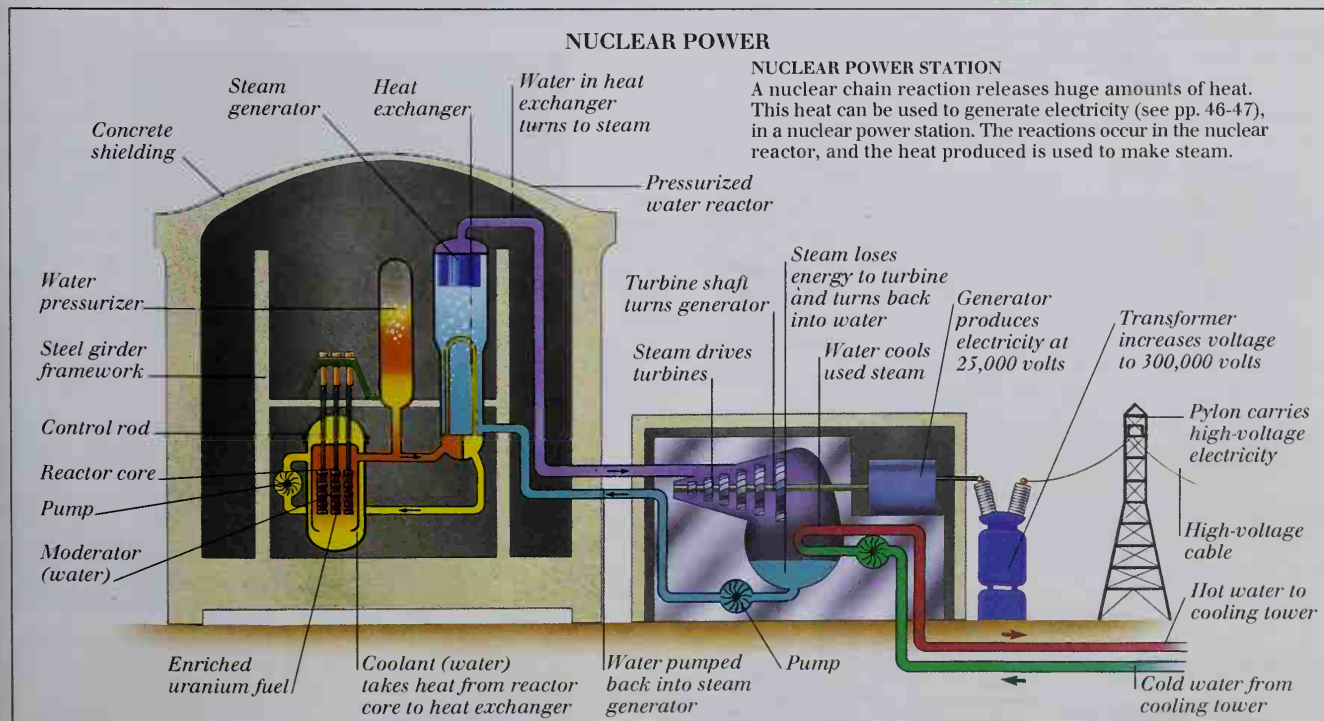

Particle physics

PARTICLE PHYSICS ATTEMPTS TO EXPLAIN matter and force in terms of tiny particles. The **atom**, once thought to be the smallest particle, is actually made of **protons**, **neutrons**, and **electrons**. But the proton and the neutron are themselves made up of smaller particles, known as **quarks**. There are four types of forces acting between matter, namely **gravitational force**, the **electromagnetic force**, the **strong nuclear force**, and the **weak interaction**. According to current theory, each of these forces is explained by the exchange of particles called **gauge bosons** between the particles of matter. For example, the **nucleus** holds together as a result of the exchange of particles called **mesons** (a type of gauge boson) between the protons and neutrons present. These exchanges can be visualized in Feynman diagrams, which show the particles involved in each type of force. The most important tools of particle physics are particle accelerators, which create and destroy particles in high-energy collisions. Analysis of these collisions helps to prove or disprove the latest theories about the structure of matter and the origin of forces. One of the current aims of large particle accelerators, such as the Large Hadron Collider at CERN (see opposite), is to prove the existence of a particle called the **Higgs boson**. It may be responsible for giving all matter mass.

HADRONS

Protons, neutrons, and mesons are examples of hadrons. A **hadron** is a particle consisting of quarks. There are six types of quarks, including the "up" and "down" quarks. The quarks of hadrons are held together by **gluons**.

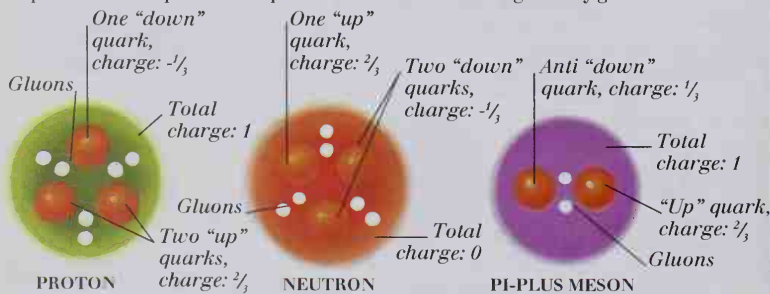

FEYNMAN DIAGRAMS

The diagrams below show which gauge bosons are exchanged to transfer each of the four forces. The horizontal lines represent the gauge boson, whereas the diagonal lines and the circles represent the two interacting particles.

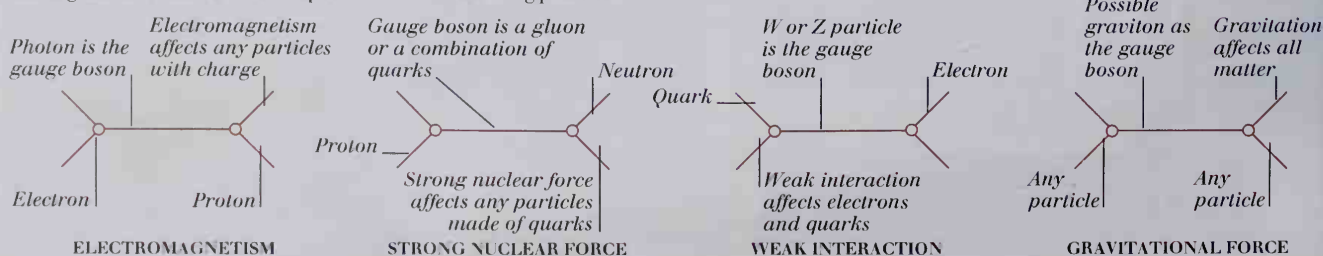

PARTICLE COLLISIONS

The images below show the results of collisions between particles in particle accelerators. Particles of opposite charge curve in different directions in the strong magnetic field of the detector.

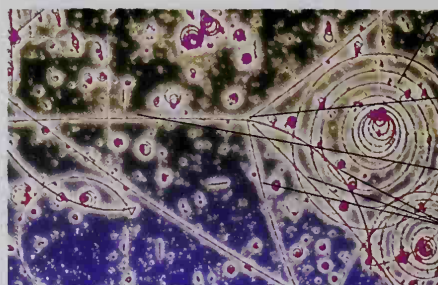

Spiral tracks of electrons in the bubble chamber
 Point of collision with proton
 Track of antiproton
 Tracks of particles created by collision

ANNIHILATION

When a particle and an antiparticle meet, they destroy each other and become energy. This energy in turn becomes new particles.



Proton
 Photon does not leave a track as it has no charge
 Tight spiraling electron tracks
 A number of particles are created in the collision

PROTON-PHOTON COLLISION

This collision between a **photon** and a proton took place in a type of detector called a bubble chamber. The colors in this photograph have been added for clarity.

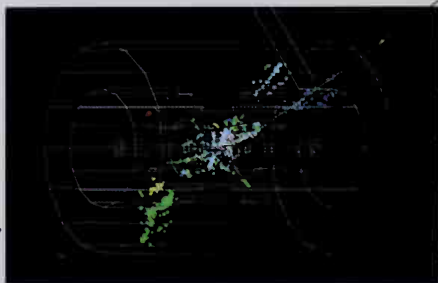

Track of a particle called a muon
 Incoming electron
 Point of collision
 Incoming positron
 Pi mesons produced by collision

ELECTRON-POSITRON COLLISION

Here, an electron collides with its antiparticle, a **positron**. The detector is linked to a computer, which produces this picture of the collision.

THE LARGE HADRON COLLIDER

MAP OF THE SITE

The Large Hadron Collider (LHC), at CERN near Geneva, will be a huge particle accelerator, in a tunnel about 100 meters below ground. The tunnel will be a ring 27 kilometers long, which is already used for

another particle accelerator, the Large Electron Positron (LEP) collider. Two beams of protons will move around in tubes at very high speed, and will be made to collide in detectors, such as the CMS (see below).

Protons and other particles will collide in the detector chambers

Site of detector

Cryogenic unit produces liquid helium

Super proton synchrotron (SPS) ring accelerates protons and injects them into the LHC

Proton synchrotron (PS) ring accelerates protons and injects them into the SPS

Linear injector



Cryogenic unit

Two sets of protons will travel in opposite directions

Site of CMS detector

The ring is 27 km long

Protons in the LHC will travel at close to the speed of light

The ring is between 70 m and 140 m underground

Pipe containing liquid helium at 4.5K (-268.7°C)

Thermal shield

Radiation shield

Iron yoke prevents the magnetic field from leaking out

Electromagnets are kept extremely cold by liquid helium

Collars hold tubes in place

Tube holding proton beams

Each tube is 0.056 m in diameter

Quench discharge pipe

Pipe containing helium gas that removes heat

Support post

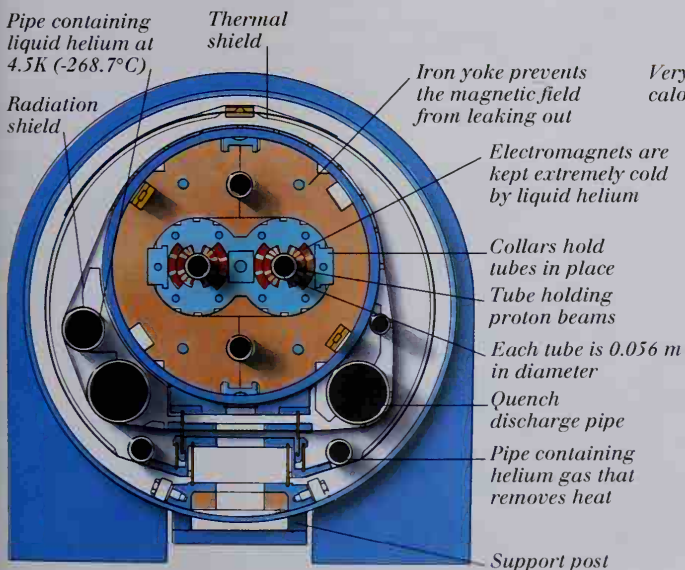

THE ACCELERATOR

In the main experiment of the LHC, protons injected into the ring will be accelerated to nearly the speed of light, traveling in opposite directions in two tubes. Centripetal force provided by powerful electromagnets keeps the protons moving in a circle.

One beam of protons enters here

Different layers of detector detect different particles

Collision takes place here

Hadron calorimeter

Superconducting coil

Very forward calorimeter

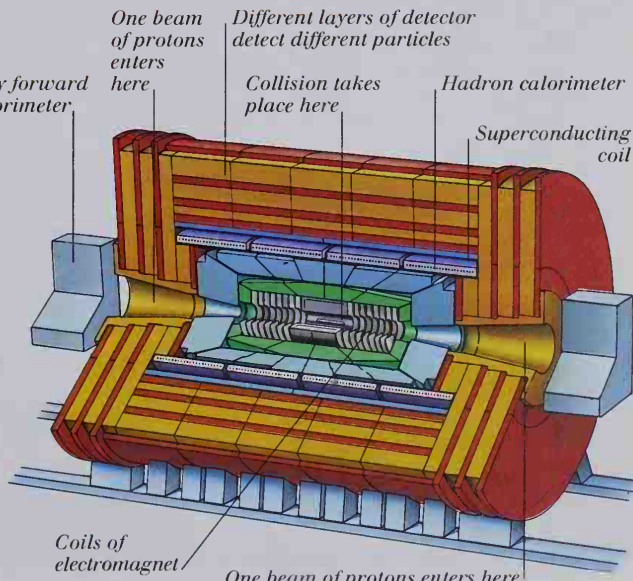

Coils of electromagnet

One beam of protons enters here

THE COMPACT SOLENOIDAL (CMS) DETECTOR

Several detectors will be built for detecting the particles produced by collisions in the LHC. The detectors have different parts that detect different types of particles. The hadron calorimeter, for example, can only detect hadrons.

Modern physics

THE SCIENTIFIC DESCRIPTION OF FORCES, energy, and matter before 1900 is known as classical physics. Modern physics – physics since 1900 – is based on quantum theory and relativity. Quantum theory deals with the behavior of tiny particles and very small amounts of energy. The quantum description of the world is very different from that which our common sense would predict. For example, it was found that a small object such as an **electron** behaves both as a wave and as a particle. The differences between the quantum world and the world of classical physics disappear on the scale of our everyday experience. However, this leads to various paradoxes, such as the Schrödinger's-cat thought experiment, in which a cat is said to be both dead and alive at the same time. Relativity also seems to contradict common sense. It shows that measurements of distance and time are not the same for everyone – that these are relative rather than absolute quantities. There are two theories of relativity: special relativity is concerned with high-speed movement at a constant velocity; general relativity is an attempt to explain gravitation and acceleration.

SCHRÖDINGER'S-CAT THOUGHT EXPERIMENT

In quantum theory, a system exists in all its possible states simultaneously until it is observed to be occupying just one of these states. Austrian physicist Erwin Schrödinger (1887–1961) attempted to demonstrate this with a thought experiment in which a cat is placed inside a box with a sample of a radioactive material and a bottle of poison. If enough radioactive material decays, it triggers the release of a hammer, which then breaks the

poison bottle, releasing deadly fumes. This sealed box and its contents are a system within which all possible states could be said to apply – either the cat is still alive, because not enough radioactive material has yet decayed to release the hammer, or it is dead, because sufficient material has already decayed and the poisonous fumes have done their work. The cat is therefore both dead and alive, until the box is opened and its one observable state is revealed.



Within the sealed system of the box, the cat occupies all possible states

Radioactive material

There is a 50/50 chance that the radioactive material will trigger the Geiger counter

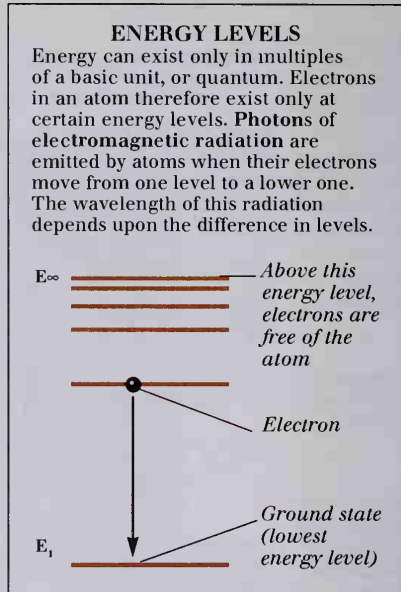

PARTICLES AND WAVES

Light is a wave – it produces interference patterns (see pp. 54-55), but it is also a stream of particles called photons. Quantum theory shows that all particles have wavelike properties. In the experiment below, electrons produce an **interference pattern**. The experiment works even when electrons are sent through the apparatus individually – which indicates that they must be interfering with themselves.

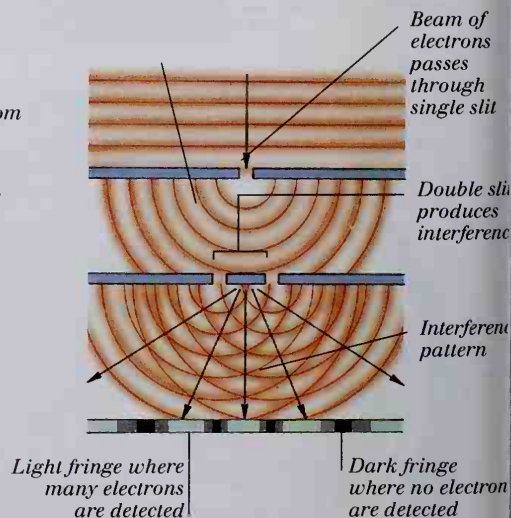

DETECTING ELECTRONS

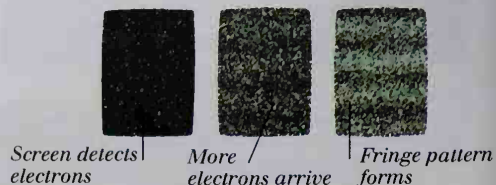

SPECIAL RELATIVITY

TRAVELING LIGHT

The speed of light is absolute – the same for all observers. This fact has strange consequences, especially for objects traveling at close to the speed of light. Spacecraft A and B are traveling at the same speed – and are therefore stationary relative to each other. A pulse of light takes one second to pass between them. As seen from spacecraft C, the path of the light is longer. The speed of light is fixed, and the only possible conclusion from this is that time runs at a different rate for C than for A and B.

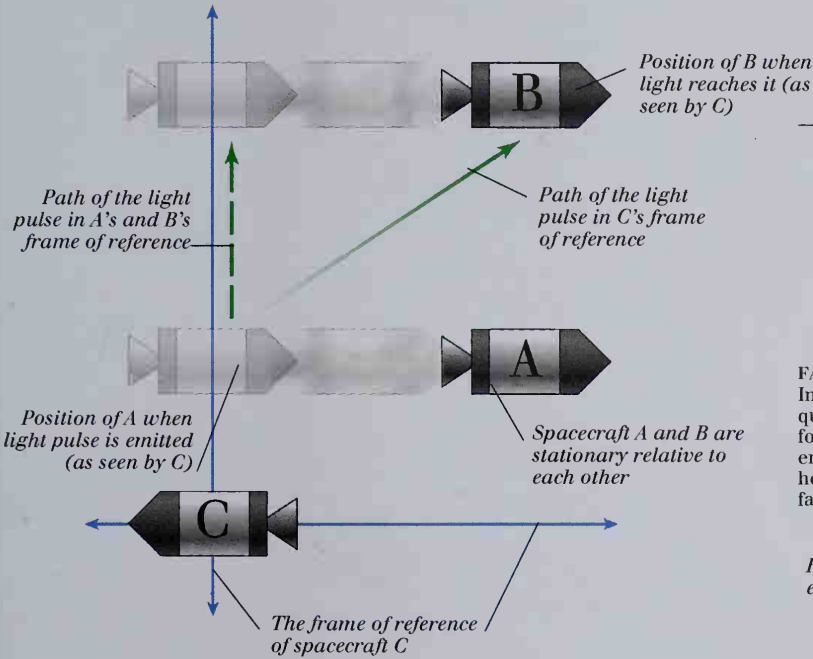

RELATIVE DISTANCE

For a meson particle traveling at close to the speed of light relative to the Earth, time runs much more slowly, and so the meson takes longer than usual to decay. Within the meson's frame of reference, time runs at the normal rate, but distances become distorted – so that the Earth is flattened, and the meson can reach the Earth's surface before it decays.

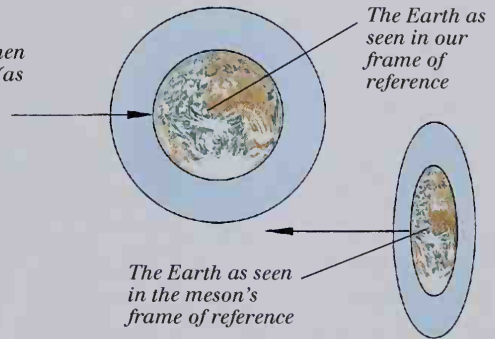

FAMOUS EQUATION

In modern physics, the mass of an object is a relative quantity. Special relativity shows that mass is also in fact a form of energy. Therefore, an object's mass increases as its energy increases. Even a stationary object has energy, however. This rest energy can be worked out using the famous equation shown below.

$$E = mc^2$$

Rest energy — E — Rest mass — m — Constant speed of light, squared — c^2

GENERAL RELATIVITY

SPACE-TIME DISTORTION

In relativity theory, time is treated as a dimension that, together with the three dimensions of space, forms the phenomenon of space-time. General relativity shows how massive objects distort space-time, and this gives rise to gravitational forces. The greater the mass, the greater the distortion. Even light does not travel through space in a straight line – it follows the distortions of space-time around massive objects.

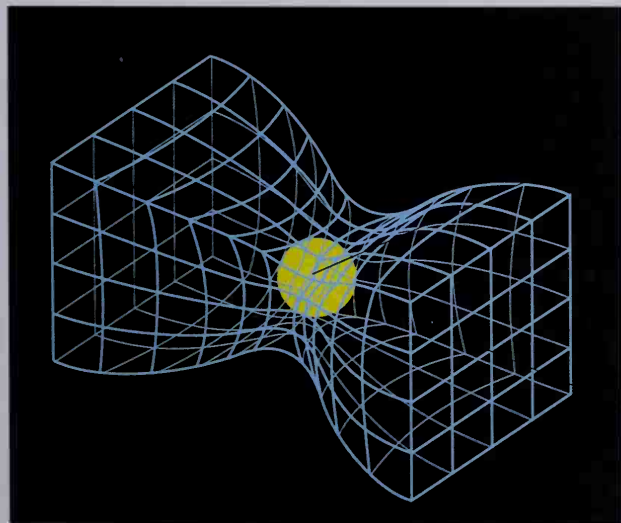

GRAVITY AND ACCELERATION

In general relativity, there is no difference between gravitation and acceleration. In free space, where there is no acceleration and no gravitational force, light travels in a straight line. However, in an accelerating frame of reference, light appears bent, as it would be by gravity.

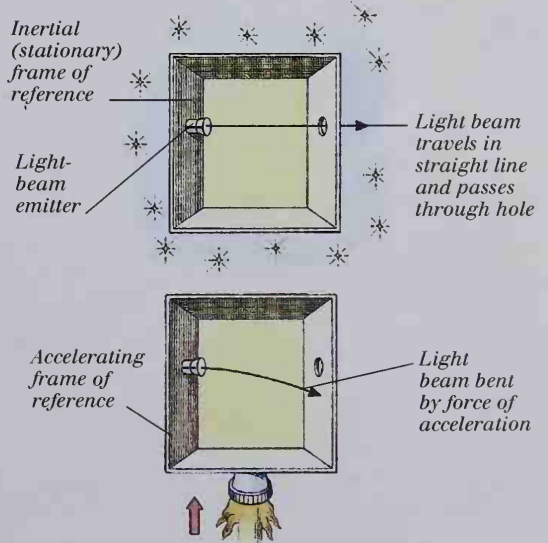



Hydrogen gas, which is produced when potassium metal reacts with water, burns with a lilac flame

CHEMISTRY

DISCOVERING CHEMISTRY	66
ELEMENTS AND COMPOUNDS	68
MIXTURES	70
ATOMS AND MOLECULES	72
PERIODIC TABLE	74
METALS AND NONMETALS	76
BONDS BETWEEN ATOMS	78
CHEMICAL REACTIONS	80
OXIDATION AND REDUCTION	82
ACIDS AND BASES	84
SALTS	86
CATALYSTS	88
HEAT IN CHEMISTRY	90
WATER IN CHEMISTRY	92
THE ACTIVITY SERIES	94
ELECTROCHEMISTRY	96
THE ALKALI METALS	98
THE ALKALINE EARTH METALS	100
TRANSITION METALS	102
CARBON, SILICON, AND TIN	104
NITROGEN AND PHOSPHORUS	106
OXYGEN AND SULFUR	108
THE HALOGENS	110
ORGANIC CHEMISTRY 1	112
ORGANIC CHEMISTRY 2	114
CHEMICAL ANALYSIS	116



Discovering chemistry

CHEMISTRY IS THE STUDY OF ELEMENTS and compounds, their properties, composition, and the way they react together to form new substances. Chemistry has an impact on our everyday lives in many ways – not least through the chemical industry, which is responsible for the large-scale production of artificial fertilizers, medicines, plastics, and other materials.

THE ROOTS OF CHEMISTRY

Two ideas dominated ancient Greek thinking about the nature of matter: the theory of the four elements, and the concept that matter is composed of tiny pieces, which the Greeks called atoms. The four-elements theory claimed that all matter was composed of the elements air, fire, water, and earth. Each element was a combination of the qualities hot or cold and wet or dry. Earth, for example, was cold and dry, while fire was hot and dry. Puzzling over the nature of matter in this way was important in the development of the philosophical basis of chemistry. The practical side of the science of chemistry was encouraged by activities such as metallurgy and alchemy.

ALCHEMY

The main quest of alchemy was the search for the hypothetical philosophers' stone, which would enable alchemists to change base metals (such as lead) into gold. The word "al" is Arabic for "the" and "khem" is the ancient name of Egypt. The exact origins of alchemy are unclear, though it seems to have begun in Egypt during the 6th century AD. In their search for the philosophers' stone, alchemists developed many important methods of working that were of benefit to chemists.

MEDICINE AND METALLURGY

Medicine and chemistry were first linked during the 16th century, in a combination known as iatrochemistry. The founder of iatrochemistry was **Paracelsus**. He changed the direction of alchemy toward a search for medicines. The connection between chemistry and metallurgy is not surprising, since metals are prepared from their ores by chemical reactions. Much about the nature of matter was learned by metallurgists studying metals and ores. An important figure in the development of metallurgy was Georg Bauer, also known as **Georgius Agricola**.

Paracelsus and Agricola helped enormously to put chemistry onto a firm experimental footing.

THE SCIENCE OF CHEMISTRY

The belief that all natural phenomena are explainable by physical laws became fashionable among scientists in the 17th century. As a result, mystical ideas lost much of their importance in natural philosophy during the 17th century, and chemistry became a true scientific discipline. In 1661, in his book *The Sceptical Chymist*, **Robert Boyle** attacked the four-elements theory. He defined an element as a pure substance that cannot be broken down by chemical means – the same as the modern definition. During this period, various theories sprang up to explain chemical reactions. Perhaps the most important of these was the phlogiston theory. Phlogiston was a hypothetical substance possessed by all matter. When an object burned, phlogiston was released, leaving ash behind. A major flaw in this theory was the fact that when metals burn they increase in weight. The theory was disproved when it was realized that oxygen was involved in burning. **Joseph Priestley** was the first chemist to isolate oxygen, calling it dephlogisticated air.

VOLTAIC PILE

Alessandro Volta noticed that when two different metals were placed in contact with each other they produced an electric current. This led him to develop the first battery, by placing layers of cardboard soaked in brine between disks of copper and zinc.



AIR PUMP

The air pump shown here was operated with levers, which worked two pistons. As the pistons moved, they extracted air from the glass dome, allowing experiments to be performed in an airless environment. The first artificial vacuum was demonstrated in the 1650s.

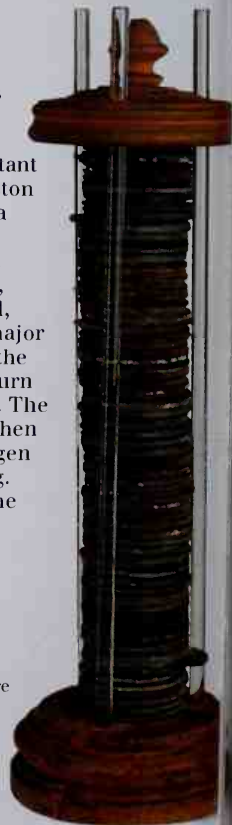

ORIGINS OF MODERN CHEMISTRY

Antoine Lavoisier found the link between the process of burning and Priestley's new gas. He did so by weighing the reactants and products of burning reactions very accurately. Such careful measurements – of mass, temperature, and other quantities – are a vital part of modern quantitative chemistry. Lavoisier discovered that the gas Priestley had called dephlogisticated air was absorbed during burning, accounting for the fact that metals gain weight as they burn. He had therefore shown the phlogiston theory to be false, and made chemistry a truly quantitative discipline. Soon after Lavoisier's discoveries, John Dalton restated the ancient Greek idea of atoms in a more modern sense. Dalton realized that atoms of the elements combined in definite ratios to form molecules.

ORGANIC CHEMISTRY AND ELECTROCHEMISTRY

The 19th century saw the emergence of organic chemistry and electrochemistry. It had long been believed that organic chemicals – those found in living organisms – were somehow different from inorganic ones. In the 1820s, Friedrich Wöhler proved that so-called organic substances could be produced from inorganic ones. At about the same time, Humphry Davy discovered several new metallic elements by passing electric current through various compounds – a technique called electrolysis. The importance of electricity to the formation of chemical bonds was realised later in the 19th century. Svante Arrhenius suggested that electrolytes – compounds or mixtures that conduct electricity – are composed of electrically charged atoms, which he named ions. The discovery of the electron, in 1897, confirmed Arrhenius' idea. It was realized that electrons are to be found in every atom, and loss or gain of an electron creates the ions that Arrhenius had predicted. The existence of electrons was also used in explanations of many chemical phenomena, including so-called oxidation and reduction (redox) reactions and acid-base reactions.

PERIODIC TABLE

Another important advance of the 19th century was spectroscopy, which allowed chemists to identify elements by the light

THE PERIODIC TABLE

Dmitri Mendeleev noticed that elements listed in order of atomic weight showed regular, repeating (periodic) properties. In 1869 he published a list of all known elements in the form of a table based upon this periodic property. He left spaces for elements that were yet to be discovered.

they emit or absorb. Spectroscopists discovered several chemical elements by observing spectra they did not recognize. With the discovery of previously unknown elements, there was an effort to organize the known elements into some order. Dmitri Mendeleev was the first to do this successfully, in 1869. He put the 63 elements known in his day into a table of rows (periods) and columns (groups), according to their properties and atomic masses. There were several gaps in the table, which Mendeleev correctly predicted would be filled as new elements were discovered.

THE 20TH CENTURY

One of the great mysteries of chemistry during the 19th century was the way chemical bonds form between atoms. One of the triumphs of the 20th century was the explanation of bonding. The idea that the electric charges of ions held certain atoms together in crystals was generally accepted, and named ionic bonding. The covalent bond – which had previously been suggested as a simple sharing of electrons between atoms – was finally fully explained in terms of molecular orbitals in the 1930s. The 20th century has also seen a huge increase in the number of synthetic materials, including plastics. This is just one feature of the dramatic rise of the chemical industry. Biochemistry also advanced rapidly during the 20th century, and the complex chemical reactions inside living cells could finally be figured out. Another important advance was X-ray crystallography, which allowed crystallographers to figure out the structure of large molecules, including DNA.

TIMELINE OF DISCOVERIES

5200 BC	– Egyptians use fire and charcoal to obtain copper from its ores
5000 BC	– First glassworks, in Egypt and Mesopotamia
425 BC	– First comprehensive atomic theory developed in Greece by Democritus
500 BC	– Philosophers suggest that matter is made of four elements (in Greece) or five elements (in China)
AD 180	– The first work on alchemy is published in Egypt. Alchemy reaches the Arab world about 600 years later
AD 900	– Chinese invent gunpowder
1661	– Robert Boyle questions the ideas of the ancient Greeks and develops a modern definition of an element
1772	– Henry Cavendish discovers hydrogen gas
1766	– Karl Scheele discovers oxygen gas. He calls it "fire air." Joseph Priestley independently discovers the gas in England two years later
1782	– Antoine Lavoisier proves that mass is conserved during chemical reactions
1785	– Lavoisier shows that hydrogen burns in oxygen to produce water
1799	– Joseph Proust shows that elements are always combined in definite proportions in a compound (Proust's Law)
1805	– English chemist John Dalton proposes modern atomic theory
1807	– The elements potassium and sodium are the first to be discovered using electrolysis, by Humphry Davy
1828	– German chemist Friedrich Wöhler produces an organic compound (urea) from inorganic reactants
1855	– Robert Bunsen invents the Bunsen burner
1860	– Cesium becomes the first element to be discovered by spectroscopy, by Robert Bunsen and his colleague Gustav Kirchhoff
1871	– Russian chemist Dmitri Mendeleev publishes his periodic table
1884	– Svante Arrhenius proposes his dissociation theory, which explains the formation of ions in solution
1909	– Sören Sörensen establishes the pH scale to measure acidity
1920s	– X-ray crystallography enables the deduction of crystal structures
1937	– Emilio Segrè finds technetium, the first artificial element
1959	– Linus Pauling produces the first comprehensive modern explanation of chemical bonding

Elements and compounds

CHEMISTRY IS THE STUDY OF MATTER. All ordinary matter consists of tiny units called **atoms** (see pp. 72-73). An **element** is a substance that contains atoms of one type only. However, pure elements are rarely found in nature – they are nearly always combined with other elements. A **compound** is a substance in which the atoms of two or more elements are combined in definite proportions. The atoms in a compound are often bound together in units called **molecules**. For example, each molecule of the compound ammonia, NH_3 , consists of one atom of nitrogen, N, bound to three of hydrogen, H. Atoms interact with one another during **chemical reactions**, making or breaking bonds to form new substances. The **products** of a reaction often have very different properties to the original **reactants**. For example, iron, a magnetic element, reacts with the yellow element sulfur to produce iron(II) sulfide, which is neither magnetic nor yellow.

Similarly, the compound mercury(II) oxide is an orange powder – very different from its constituent elements.

A SELECTION OF ELEMENTS AND COMPOUNDS

These pure samples of elements and compounds show the diversity of substances found in nature.

Carbon present as graphite crystals and C_{60} , buckminsterfullerene



CARBON BLACK

Elemental tin, Sn

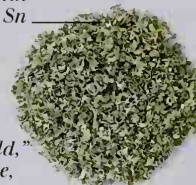

TIN



IRON PYRITES

"Fool's gold," iron sulfide, FeS_2

Macromolecular crystals of I_2



IODINE

Hydrogen gas, H_2



HYDROGEN



ALUMINUM Powder coated with aluminum oxide, Al_2O_3



LEAD SHOT

Elemental lead, Pb

Lead sulfide, PbS



GALENA

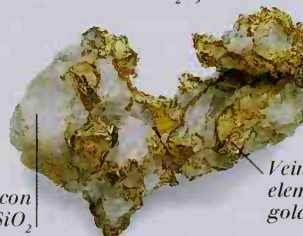

Veins of elemental gold, Au

GOLD AND QUARTZ CRYSTAL

Quartz, silicon dioxide, SiO_2

Elemental mercury, Hg



MERCURY



Elemental nickel, Ni

NICKEL

MOLECULAR MODELS

Many compounds exist as individual molecules. Models of molecules can help us to understand and predict chemical reactions. Space-filling models show how the atoms that make up a molecule overlap. Ball and stick models show the bonds and bond angles between the atoms.

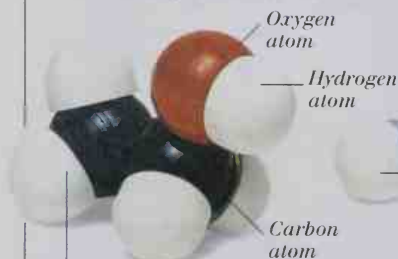

ETHANOL, $\text{C}_2\text{H}_5\text{OH}$

MOLECULES

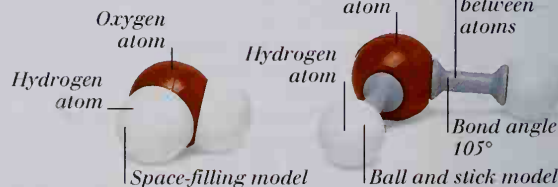
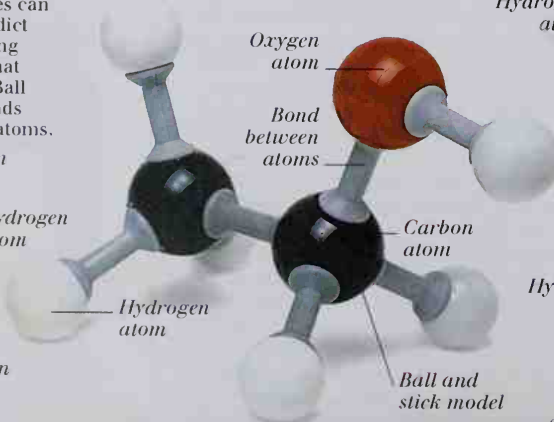

WATER, H_2O

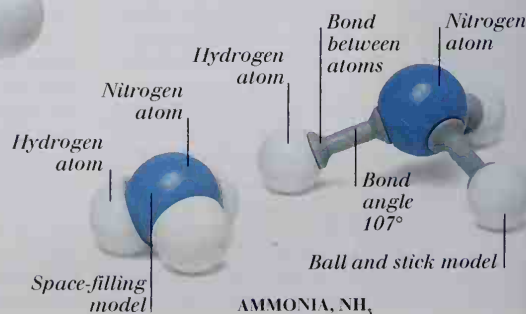

AMMONIA, NH_3

PREPARATION OF IRON(II) SULFIDE

CHEMICAL REACTION

Heating the elements iron and sulfur together causes a chemical reaction to occur. The iron and sulfur combine in the ratio 1:1 to form the compound iron(II) sulfide. With equal numbers of iron and sulfur atoms, the elements would combine with no residue.

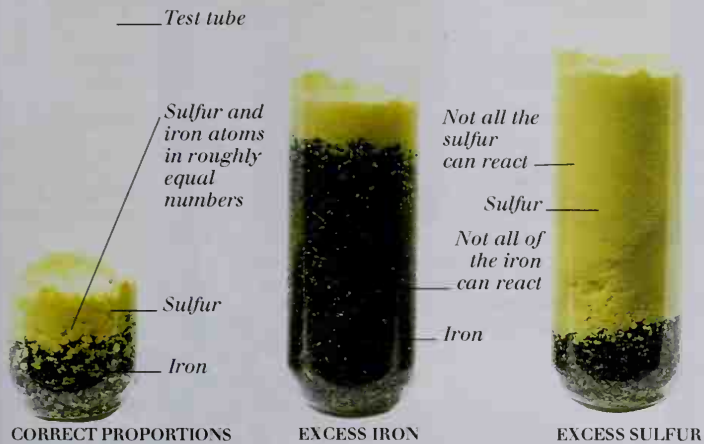

MIXING IRON AND SULFUR

Magnetic iron and yellow sulfur retain their properties, and can be easily separated, in a mixture (see pp. 70-71).



IRON(II) SULFIDE
Iron and sulfur chemically combine to form iron(II) sulfide, FeS, which is a gray, non-magnetic solid at room temperature.

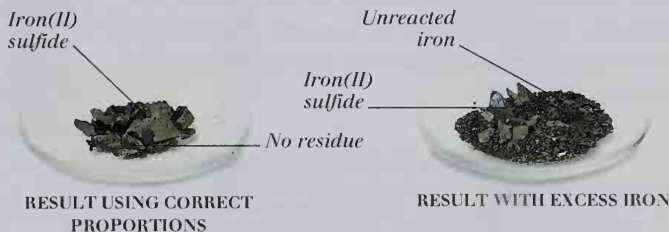

MERCURY(II) OXIDE

DECOMPOSITION

When heated, the compound mercury(II) oxide decomposes to produce its constituent elements, mercury and oxygen. The heat provides the energy needed to break the bonds between the atoms of the two elements. The oxygen is a gas at room temperature, and escapes into the air.

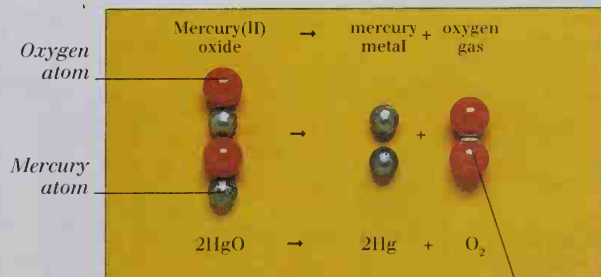
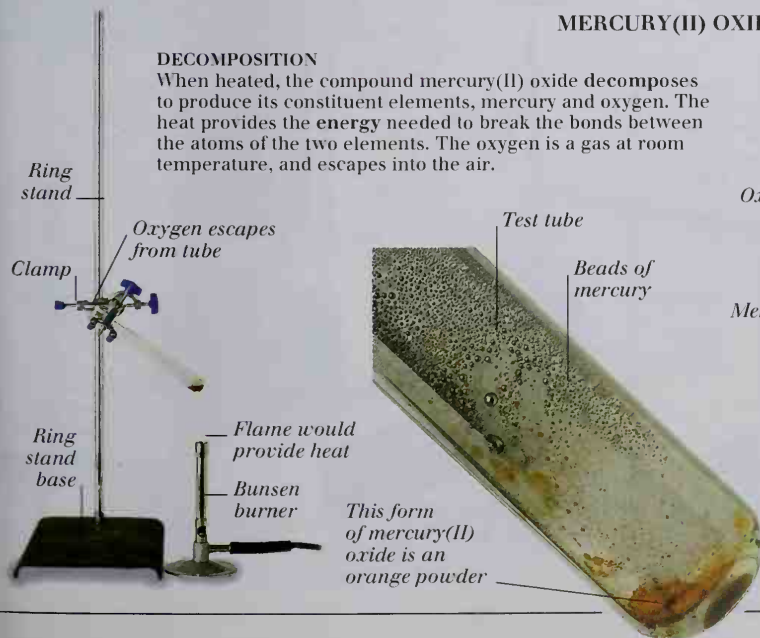

MOLECULAR MODEL OF REACTION

CLOSE-UP VIEW

A closer view of the reaction shows tiny beads of the mercury metal produced. The models above present a molecular view of the reaction, while the equation summarizes the reaction symbolically.

Mixtures

A MIXTURE CONTAINS TWO or more pure substances (elements or compounds), which may be solids, liquids, or gases. For example, air is a mixture of gases, cement is a mixture of solids, and seawater is a mixture of solids, liquids, and gases. A solution is a common type of mixture, consisting of a solute (often a solid) mixed evenly with a solvent (usually liquid). When the solvent is water, the solute particles are usually ions. Other types of mixtures include colloids, like milk, in which the dispersed particles are slightly larger than ions, and suspensions, in which they are larger still. Because the substances making up a mixture are not chemically combined (see pp. 78-79), they can be separated easily. Chromatography is used to separate mixtures for analysis, for example in Breathalyzers. A technique called filtration is used to separate suspensions such as muddy water. Solutions may be separated by distillation, in which the solvent is boiled off and collected, and the solute is left behind. If both the solute and the solvent are liquids, then a technique called fractional distillation is used (see pp. 112-115).

AIR AS A MIXTURE

The colored balls in this column represent the proportions of gases in dry air. Usually, air also contains water vapor and dust particles.

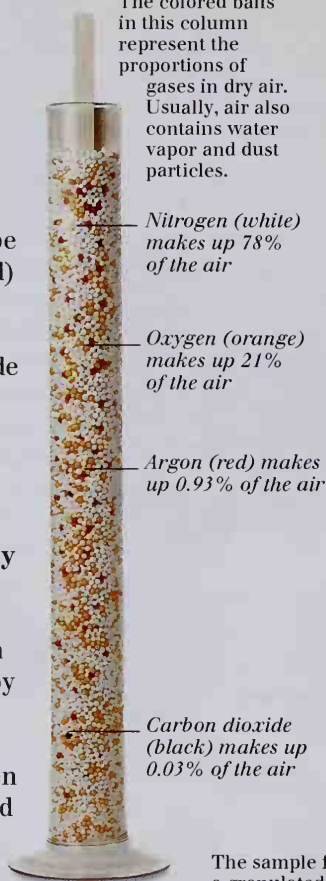

SOLUTIONS

Nickel(II) nitrate is a solid at room temperature. It dissolves well in water to give a green colored aqueous solution.

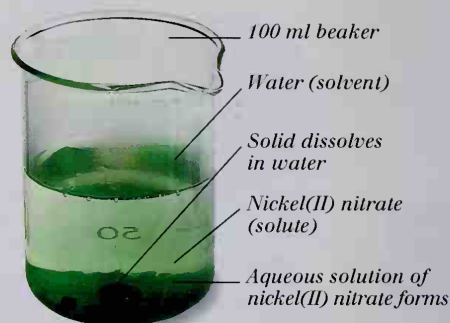

SOLUTION OF NICKEL(II) NITRATE IN WATER

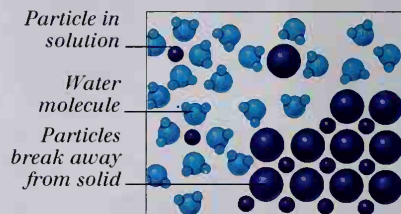

MICROSCOPIC VIEW

When a solid dissolves in a liquid solvent such as water, the particles of the solid break away and mix evenly and thoroughly with particles of the liquid.

PAPER CHROMATOGRAPHY

Ink from a felt-tip pen is dissolved in alcohol in a glass dish. The alcohol soaks into the absorbent filter paper, carrying the ink with it. Colored ink is a mixture of several pigments, which bind to the paper to different extents. Those pigments that bind loosely move more quickly up the paper than the others, and so the ink separates into its constituent pigments.

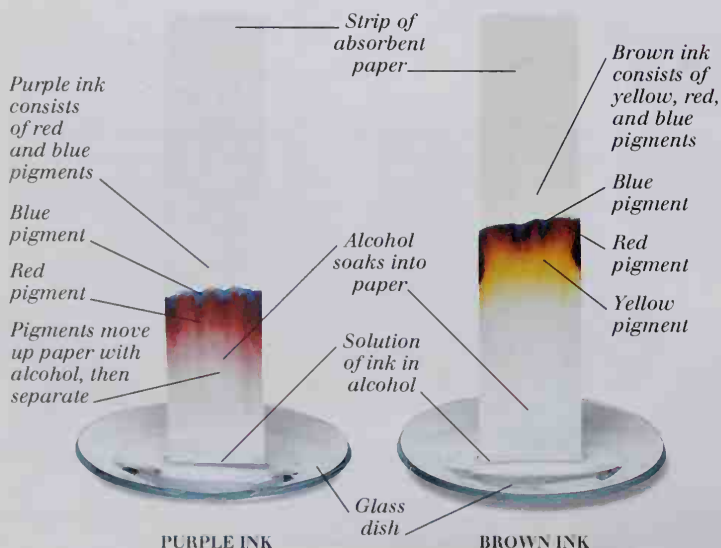

GAS CHROMATOGRAPHY

The sample for analysis is vaporized and carried through a granulated solid by a moving stream of an inert gas such as helium. Different parts of the sample travel at different rates through the solid, and can be identified by a sensitive detector.

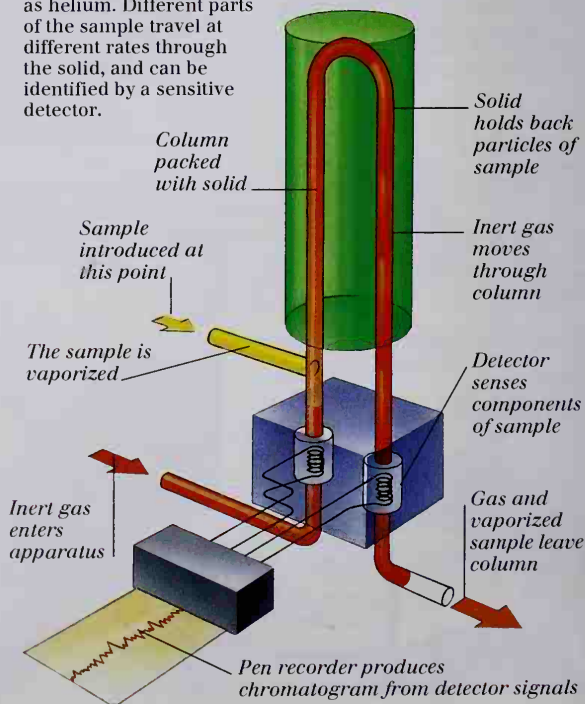

FILTRATION

FILTERING MUDDY WATER

Muddy water is a mixture. It contains some substances in solution, and some larger soil particles in suspension. Filter paper acts like a sieve, allowing water and anything dissolved in it to pass through, but keeping back the suspended particles of soil.



Glass funnel

Filter paper

Soil particles trapped by filter paper

250 ml conical flask

Solution has no large soil particles in it

Muddy water contains suspended soil particles

Some of the larger soil particles fall to the bottom of the flask



Small flask

DISTILLATION

DISTILLING SODIUM DICHROMATE SOLUTION

If the solvent of a solution is boiled away, the solute particles are left behind. In distillation, the solvent is boiled away and then condensed to a pure liquid, which is collected. Here, an aqueous solution of sodium dichromate, $\text{Na}_2\text{Cr}_2\text{O}_7$, is distilled.

Bulb of thermometer measures the vapor temperature

Clamp

Solution of sodium dichromate

Water vapor forms as solution boils

Cold water in the condenser jacket cools water vapor, to form liquid water

Cold water flows into the condenser jacket

Warmer water flows out of the condenser jacket

Gauze

Tripod

Gas flame heats the flask

Bunsen burner

Pure water collects in the round-bottomed flask

Thermometer

Condenser

Connector

Solid sodium dichromate

Round-bottomed flask

Pure water

Rubber tube

SEPARATED COMPONENTS

As the water boils away, solid sodium dichromate remains in one flask, and pure water collects in the other. The distillation is continued until the components of the mixture have been completely separated.

Atoms and molecules

EVERY ATOM CONTAINS AN equal number of electrically charged protons and electrons, and a number of uncharged neutrons. Neutrons and the positively charged protons are found in the central nucleus. The nucleus is surrounded by negatively charged electrons, which take part in chemical bonding (see pp. 78-79). Each element has a unique atomic number – the number of protons in its atoms – though the number of neutrons varies between different isotopes of the element. An atom's mass may be given simply as the total number of neutrons and protons, since these particles have nearly equal masses, far greater than that of an electron. The relative atomic mass (RAM) is a more precise measure, based on the accurately determined atomic mass of a carbon isotope. The sum of the RAMs of the elements making up a compound is called the relative molecular mass (RMM). One mole of a substance has the same mass in grams as its RAM or RMM. The mole is a useful unit, because it specifies a fixed number of atoms, ions, or molecules.

ATOM OF BORON
Every boron atom has five electrons in two electron shells around the nucleus. In each shell, electrons are most likely to be found in regions known as orbitals.

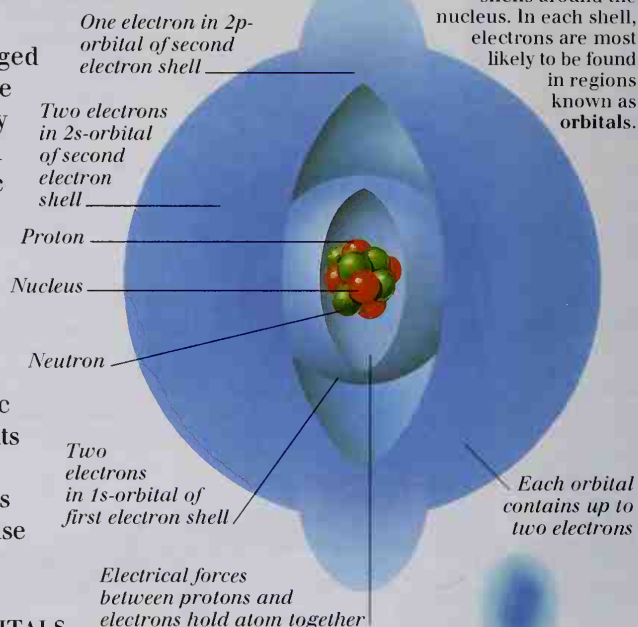

ATOMIC ORBITALS

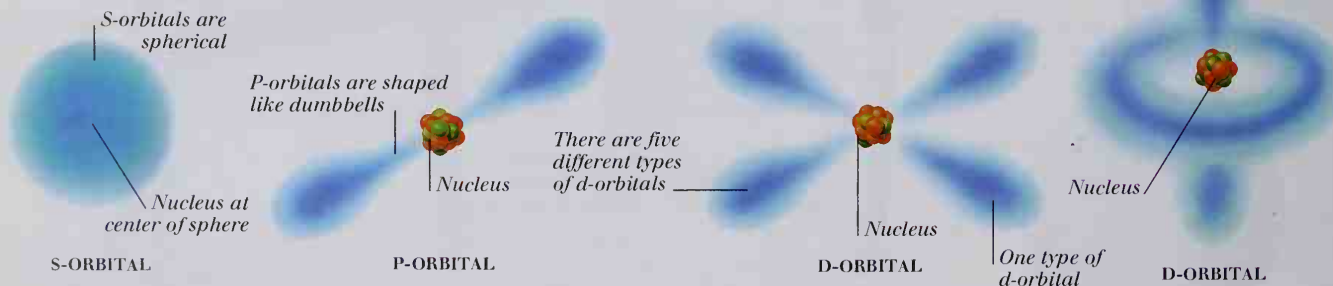

Electrical forces between protons and electrons hold atom together

RELATIVE ATOMIC MASS (RAM)

NUCLEUS OF BORON-10

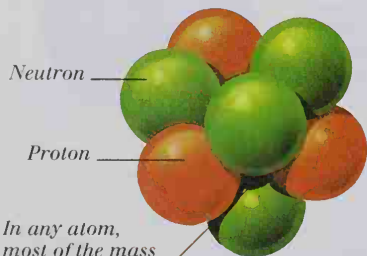

ISOTOPES

An element's atoms are found in various chemically identical forms called isotopes, which differ only in the number of neutrons in the nucleus. Different natural samples of an element have the same proportions of the different isotopes. An element's RAM takes into account the natural abundances of different isotopes. The RAM for boron is just less than 11 (actually, 10.8) since most of the atoms in nature are of boron-11.

NUCLEUS OF BORON-11

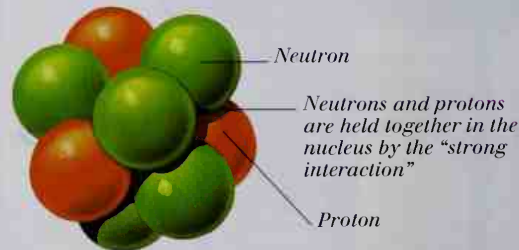

Every boron atom has five protons in its nucleus

Boron-11 atom has six neutrons in its nucleus

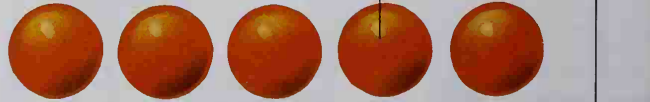

One mole of any gas at STP would fill up more than 22 of these bottles

GAS MOLAR VOLUME



ONE LITER BOTTLE



BOX CONTAINING ONE MOLE OF GAS

GAS VOLUME AT STP
One mole of any gas at standard temperature and pressure (STP) always occupies 22.4 liters of space. Although the number of particles (atoms or molecules) making up one mole of a gas is extremely large, each particle is very tiny. This means that the volume of a gas depends upon only the number of particles present, and not on the size of each particle. The box and the bottle (left) give an idea of the molar volume of any gas at STP.

PREPARING A 0.1 M SOLUTION OF COBALT CHLORIDE

0.1 MOLAR SOLUTION OF COBALT CHLORIDE
Enough water is mixed thoroughly with 0.1 mole of cobalt chloride (below left) to make exactly one liter of solution. The cobalt chloride dissolves to form a 0.1 molar (0.1M) solution. This is the concentration of the solution, sometimes known as its molarity.

Plastic stopper



Volumetric flask

Neck of flask is narrow so that it may be accurately filled

Etched mark on flask indicates one liter capacity

Solution of cobalt chloride

ONE MOLE OF COPPER
Copper has an RAM of 64.4, so the molar mass of copper is 64.4 grams. The number of atoms present is 6.02×10^{23} .

126.9 grams of iodine (one mole)

ONE MOLE OF IODINE
The element iodine has an RAM of 126.9. The molar mass of iodine is 126.9 grams. The number of atoms, ions, or molecules in one mole of any substance is 6.02×10^{23} - a figure known as Avogadro's number.



64.4 grams of copper (one mole)

Copper is a metallic element

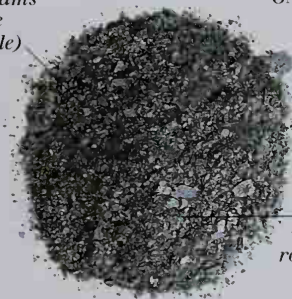

Iodine is a violet solid at room temperature

0.1 MOLE OF COBALT CHLORIDE
The RMM of hydrated cobalt chloride, $\text{CoCl}_2 \cdot 6\text{H}_2\text{O}$, is 226.9, obtained by adding the RAMs of each of the atoms making up the compound. Here, a chemical balance is used to measure accurately 0.1 mole of the substance, which has a mass of 22.69 grams.

Cobalt chloride is a red solid at room temperature

The balance has been tared, or set to zero, with the empty beaker on the pan, so that the mass of the sample is displayed



50 ml beaker

Pan

Accurate chemical balance



Digital readout shows that the mass of the sample is 22.69 grams





The periodic table

THE CHEMICAL ELEMENTS CAN BE arranged according to their **atomic number** (the number of **protons** in the **nuclei** of their **atoms**) and the way in which their **electrons** are organized. The result is the periodic table. **Elements** at the beginning of each horizontal row, or period, have one electron in the outer **electron shell** of their atoms (see pp. 72-73). All of the elements in each vertical column, or group, of the table have similar chemical properties because they all have the same number of outer electrons. The elements of the last group of the table, group 18, have full outer electron shells, and are inert, or unreactive. These elements are called the **noble gases**. Moving down the table, the length of the periods increases in steps, because as the atoms become larger, more types of electron **orbitals** become available. Periods six and seven are 32 elements long, but for simplicity a series of elements from each of these periods is placed separately under the main table.

Group 1		Group 2		Group 3	Group 4	Group 5	Group 6	Group 7	Group 8	Group 9
1 H Hydrogen 1.0		3 Li Lithium 6.9	4 Be Beryllium 9.0							
11 Na Sodium 23.0		12 Mg Magnesium 24.3								
19 K Potassium 39.1	20 Ca Calcium 40.1	21 Sc Scandium 45.0	22 Ti Titanium 47.9	23 V Vanadium 50.9	24 Cr Chromium 52.0	25 Mn Manganese 54.9	26 Fe Iron 55.9	27 Co Cobalt 58.9		
37 Rb Rubidium 85.5	38 Sr Strontium 87.6	39 Y Yttrium 88.9	40 Zr Zirconium 91.2	41 Nb Niobium 92.9	42 Mo Molybdenum 95.9	43 Tc Technetium (99)	44 Ru Ruthenium 101.0	45 Rh Rhodium 102.9		
55 Cs Cesium 132.9	56 Ba Barium 137.3	57-71	72 Hf Hafnium 178.5	73 Ta Tantalum 180.9	74 W Tungsten 185.9	75 Re Rhenium 186.2	76 Os Osmium 190.2	77 Ir Iridium 192.2		
87 Fr Francium 223.0	88 Ra Radium 226.0	89-103	104 Unq Unnilquadium (261)	105 Unp Unnilpentium (262)	106 Unh Unnilhexium (263)	107 Uns Unnilseptium (262)	108 Uno Unniloctium (265)	109 Une Unnilennium (266)		

s-block *Relative atomic mass is estimated, as element exists fleetingly* *d-block* *Disputes over the discovery and naming of elements 104-109 have led to temporary systematic Latin names*

KEY TO TYPES OF ELEMENTS

 ALKALI METALS	 ACTINIDES
 ALKALINE EARTH METALS	 POOR METALS
 TRANSITION METALS	 SEMIMETALS
 LANTHANIDES (RARE EARTHS)	 NONMETALS
	 NOBLE GASES

57 La Lanthanum 138.9	58 Ce Cerium 140.1	59 Pr Praseodymium 140.9	60 Nd Neodymium 144.2	61 Pm Promethium (145)	62 Sm Samarium 150.4
89 Ac Actinium 227.0	90 Th Thorium 232.0	91 Pa Protactinium 231.0	92 U Uranium 238.0	93 Np Neptunium (237)	94 Pu Plutonium (242)

f-block

ARTIFICIAL ELEMENTS

Uranium, atomic number 92, is the heaviest element found on Earth. Heavier elements are inherently unstable, because the nuclei of their atoms are too large to hold together. The transuranic elements, atomic numbers 93 to 109, are only produced artificially in the laboratory.

NOBLE GASES

Group 18, on the right of the table, contains elements whose atoms have filled outer electron shells. This means that they are inert elements, reacting with other substances only under extreme conditions, and so forming few compounds.

			Group 13 Group 14 Group 15 Group 16 Group 17					Group 18
			5 B Boron 10.8	6 C Carbon 12.0	7 N Nitrogen 14.0	8 O Oxygen 16.0	9 F Fluorine 19.0	2 He Helium 4.0
			15 Al Aluminum 27.0	14 Si Silicon 28.1	15 P Phosphorus 31.0	16 S Sulfur 32.1	17 Cl Chlorine 35.5	10 Ne Neon 20.2
Group 10	Group 11	Group 12	31 Ga Gallium 69.7	32 Ge Germanium 72.6	33 As Arsenic 74.9	34 Se Selenium 79.0	35 Br Bromine 79.9	18 Ar Argon 40.0
28 Ni Nickel 58.7	29 Cu Copper 65.5	30 Zn Zinc 65.4	49 In Indium 114.8	50 Sn Tin 118.7	51 Sb Antimony 121.8	52 Te Tellurium 127.6	53 I Iodine 126.9	36 Kr Krypton 83.8
46 Pd Palladium 106.4	47 Ag Silver 107.9	48 Cd Cadmium 112.4	81 Tl Thallium 204.4	82 Pb Lead 207.2	83 Bi Bismuth 209.0	84 Po Polonium 210.0	85 At Astatine (211)	54 Xe Xenon 131.3
78 Pt Platinum 195.1	79 Au Gold 197.0	80 Hg Mercury 200.6	86 Rn Radon 222.0					86 Rn Radon 222.0

d-block

p-block

Different blocks of the periodic table contain elements whose atoms have different orbitals in their outer electron shells

Lanthanides and actinides placed separately from rest of periods six and seven

Moving to the adjacent element along a period, atomic number increases by one

65 Eu Europium 152.0	64 Gd Gadolinium 157.5	65 Tb Terbium 158.9	66 Dy Dysprosium 162.5	67 Ho Holmium 164.9	68 Er Erbium 167.3	69 Tm Thulium 168.9	70 Yb Ytterbium 175.0	71 Lu Lutetium 175.0
95 Am Americium (243)	96 Cm Curium (247)	97 Bk Berkelium (247)	98 Cf Californium (251)	99 Es Einsteinium (254)	100 Fm Fermium (253)	101 Md Mendelevium (256)	102 No Nobelium (254)	103 Lr Lawrencium (257)

f-block

Metals and nonmetals

MOST OF THE ELEMENTS ARE METALS. Metals are usually lustrous (shiny), and, apart from copper and gold, are silver or gray in color. They are all good conductors of heat and electricity, and are ductile (capable of being drawn into wire) and malleable (capable of being hammered into sheets) to different extents. Found at the left-hand side of the periodic table (see pp. 74-75), metals have few outer **electrons**, which they easily lose to form **cations**. Their **compounds** generally exhibit **ionic bonding** (see pp. 78-79).

Most nonmetals are gases at room temperature, and generally form **anions**. Many simple ionic compounds are formed by metal **atoms** losing electrons to nonmetals, and the resulting ions bonding to form **macromolecules**. Sodium and chlorine react in this way to form sodium chloride. In nature, most metals are found not as **elements**, but in compounds known as **ores**. Most metals easily combine with oxygen to form metal oxides, and many ores consist of metal oxides. The simple removal of oxygen is enough to extract a metal from such an ore. The more **reactive** a metal is, the more **energy** is needed for its extraction. Iron can be extracted relatively easily from iron oxide, while more reactive sodium must be extracted by a powerful electric current.

METALLIC ELEMENTS

Like many metals, tin is lustrous



TIN

A layer of gray aluminum oxide coats the particles of aluminum powder



ALUMINUM POWDER



COPPER TURNINGS

Magnesium, a typical metal, is ductile

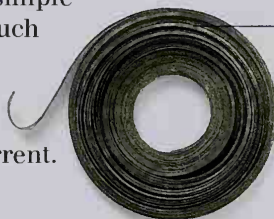

MAGNESIUM RIBBON

CATIONS AND ANIONS

Outer electron orbitals

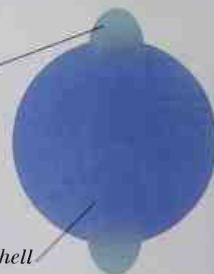

NONMETAL ATOM

Nonmetal atoms have a nearly filled outer electron shell

Negative ion

Gaining electrons gives a stable configuration

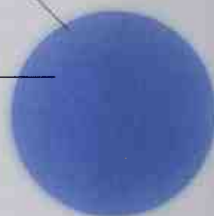

NONMETAL ANION

Metals have few electrons in their outer shell

Outer electron orbitals

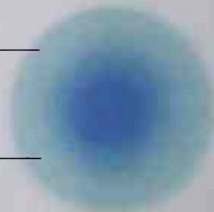

METAL ATOM

Sodium metal coated with a layer of sodium chloride

Heat of the reaction with chlorine ignites piece of sodium

Sodium chloride

Losing outer electrons makes the electron configuration more stable

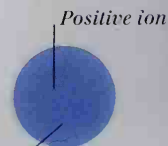

METAL CATION

Gas jar



CHLORINE GAS

Chlorine is a greenish yellow poisonous gas at room temperature. It is in group 17 of the periodic table.

FORMATION OF SODIUM CHLORIDE FROM ITS ELEMENTS

When metallic sodium, Na, is gently heated and placed in the nonmetallic gas chlorine, Cl₂, a violent exothermic reaction occurs. The product of the reaction is sodium chloride, NaCl – the familiar white crystals of common salt.

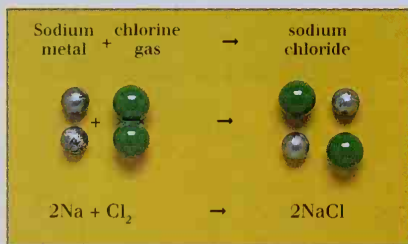

MOLECULAR VIEW

Each chlorine molecule has two chlorine atoms. Two sodium atoms react with each chlorine molecule, to form sodium chloride (see p. 79). Electrons are transferred from the sodium atoms to the chlorine atoms.

Chlorine gas



SODIUM METAL

Like most metals, sodium is silver-gray. It is a soft metal, found in group 1 of the periodic table.

Sodium is easily cut, exposing its luster

SODIUM CHLORIDE

Sodium chloride is a white solid at room temperature. It consists of macromolecules.

EXTRACTION OF METALS

IRON FROM IRON OXIDE

Carbon can be used to extract iron from the compound iron oxide, which is found in many iron ores. The reaction needs a relatively low input of heat energy in order to proceed.

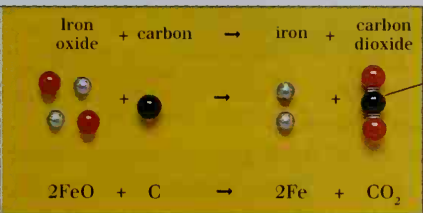
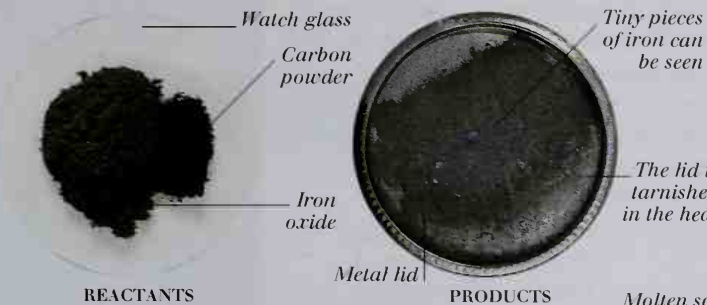

MOLECULAR VIEW

Iron oxide is **decomposed** by heat. The oxygen atoms produced bond to carbon atoms, forming carbon dioxide gas. This is a **redox** reaction.

Carbon dioxide leaves the reaction as a gas

THE DOWNS PROCESS

The industrial-scale extraction of sodium metal is normally achieved by the **electrolysis** of molten sodium chloride. In the Downs Process, a small amount of calcium chloride is added to the sodium chloride to lower its melting point.

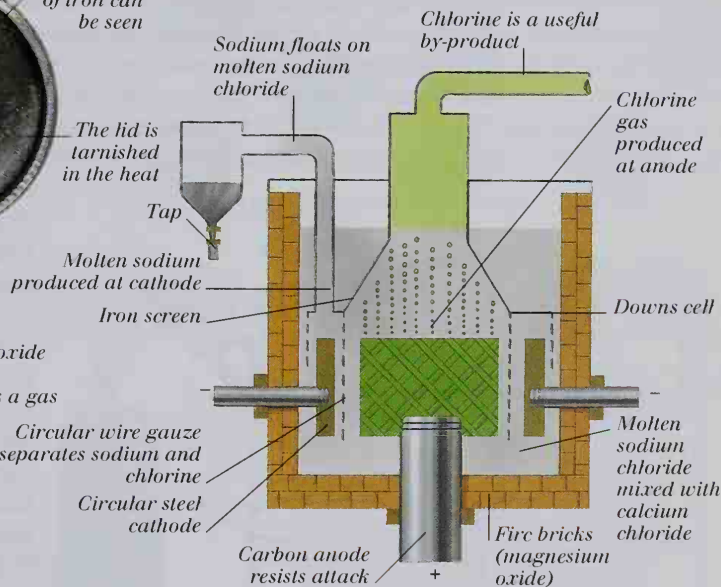

METALS AND OXYGEN

BURNING MAGNESIUM

In the reverse process of extraction from metal oxides, most pure metals readily combine with oxygen. Here, magnesium ribbon **burns** with a bright white flame as it reacts with oxygen from the air. Magnesium is used in fireworks (see pp. 100-101), and was once common in photographic flashbulbs.

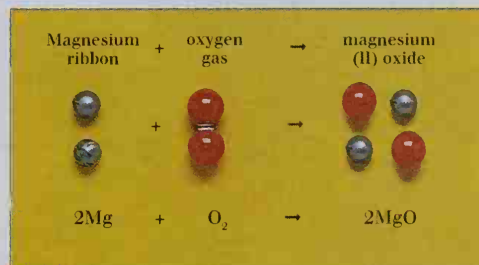

MOLECULAR VIEW

Magnesium ribbon consists of millions of magnesium atoms, Mg, only. Oxygen in the air exists as **diatomic** molecules. During the reaction, bonds form between the magnesium atoms and oxygen atoms.

Smoke consists of fine particles of magnesium(II) oxide

This reaction gives out heat (exothermic reaction)

Bright white flame

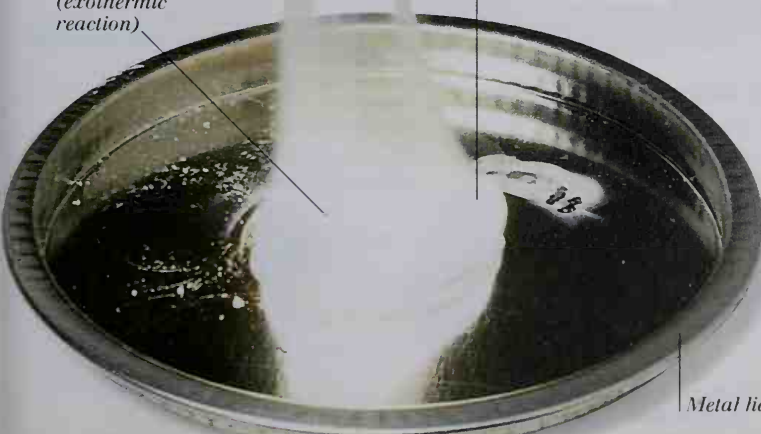

MAGNESIUM(II) OXIDE ASH

After burning, an ash of magnesium(II) oxide, MgO, is left. This is a white compound of magnesium (a metal) and oxygen (a nonmetal).

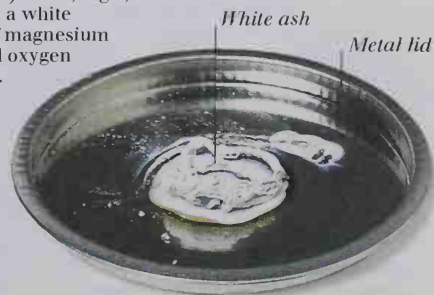

Bonds between atoms

ATOMS CAN JOIN – OR BOND – in many ways. Instruments called **atomic force microscopes** produce images of actual atoms, revealing these bonds. The two most important types of bonding are **ionic bonding** and **covalent bonding**. **Compounds** are referred to as ionic or covalent depending on the type of bonding that they exhibit. In ionic bonding, a transfer of **electrons** from one atom to another creates two **ions** with opposing electric charge. The transfer is generally from a metal to a nonmetal (see pp. 76-77). Electrostatic attraction between the ions of opposite charge holds them together. Ionic compounds form **macromolecules** – giant

COVALENT AND IONIC COMPOUNDS

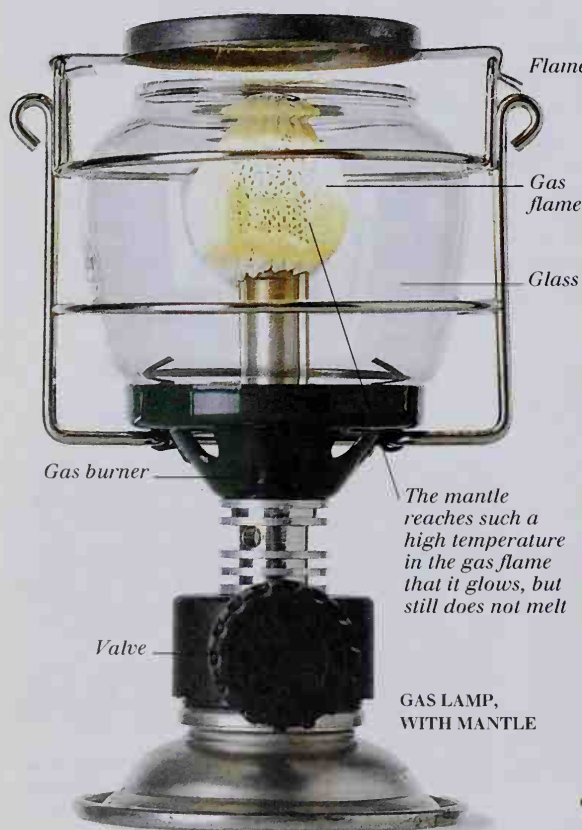

GAS LAMP,
WITH MANTLE

structures consisting of millions of ions. A familiar example of an ionic compound is sodium chloride (common salt). Each grain of common salt is a macromolecule. Atoms that are bound covalently share electrons in their outer electron shells. These shared electrons are found within regions called **molecular orbitals**. Another important type of bonding, **hydrogen bonding**, occurs between molecules of many hydrogen-containing compounds, and is the cause of some of the unusual properties of water.

ATOMIC FORCE MICROSCOPE IMAGE

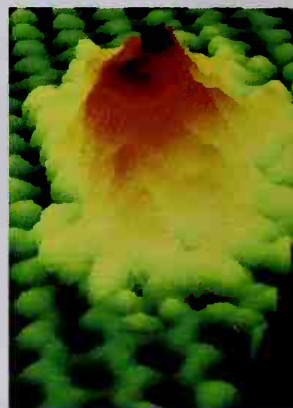

This image shows atoms of gold on a graphite surface. The colors are added to the image for clarity. The graphite atoms are joined by covalent bonds.



CANDLE
Wax melts and then vaporizes in the heat of the candle flame
Candle wax is quite soft, and melts easily, like many covalent compounds

RELATIVE MELTING POINTS

A covalent compound melts when the weak bonds between its molecules break. An ionic substance consists of ions held together by strong bonds in a giant macromolecule. More energy is needed to break these bonds, so ionic substances generally have higher melting points than covalent ones. Candle wax (covalent) melts at a lower temperature than a gas mantle (ionic), which can be heated until it glows white hot without melting.

CANDLE WAX,
A COVALENT COMPOUND

AN EXAMPLE OF IONIC BONDING

1. NEUTRAL ATOMS OF LITHIUM AND FLUORINE

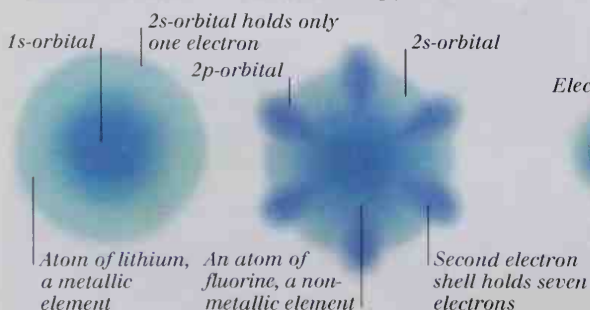

2. ELECTRON TRANSFER

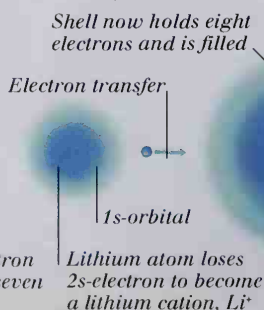

3. IONIC BONDING: LITHIUM FLUORIDE

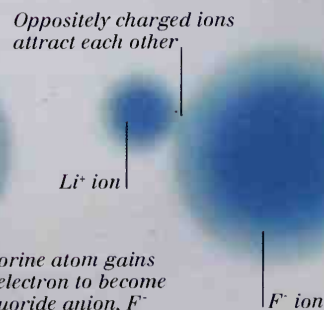

MOLECULAR ORBITALS

The outer electron orbitals (see pp. 72-73) of atoms can overlap to form molecular orbitals, which make the covalent bond. Sometimes, s- and p-orbitals of an atom form combined orbitals, called **hybrid orbitals**, prior to forming molecular orbitals.

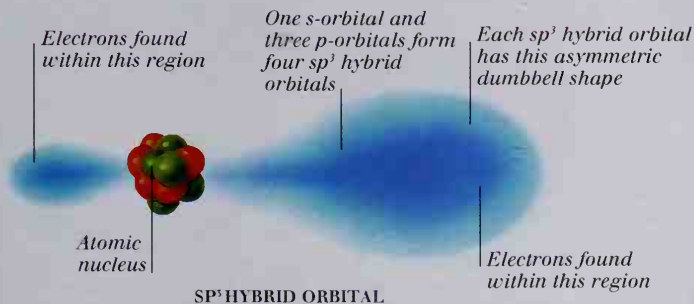
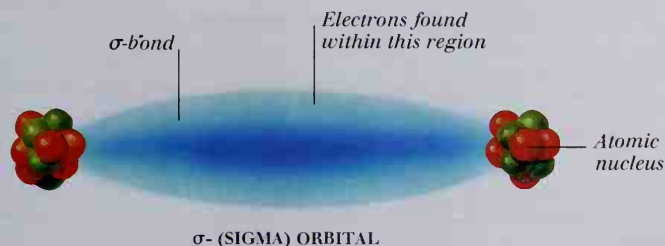
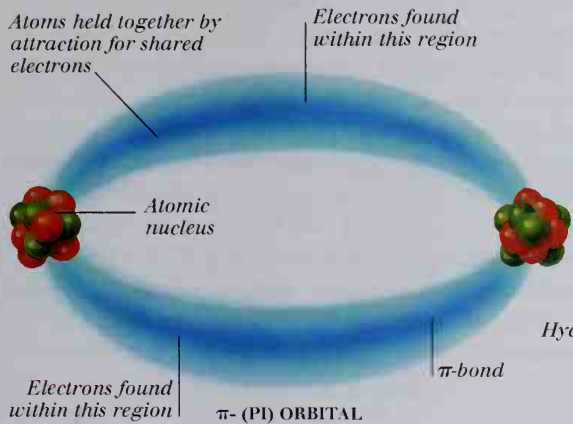

HYDROGEN BONDING

Hydrogen bonds occur between some hydrogen-containing molecules, such as water. In water molecules, negatively charged electrons are concentrated around the oxygen atom, making it slightly negatively charged relative to the hydrogen atoms. Oppositely charged parts of neighboring molecules attract each other, forming hydrogen bonds.

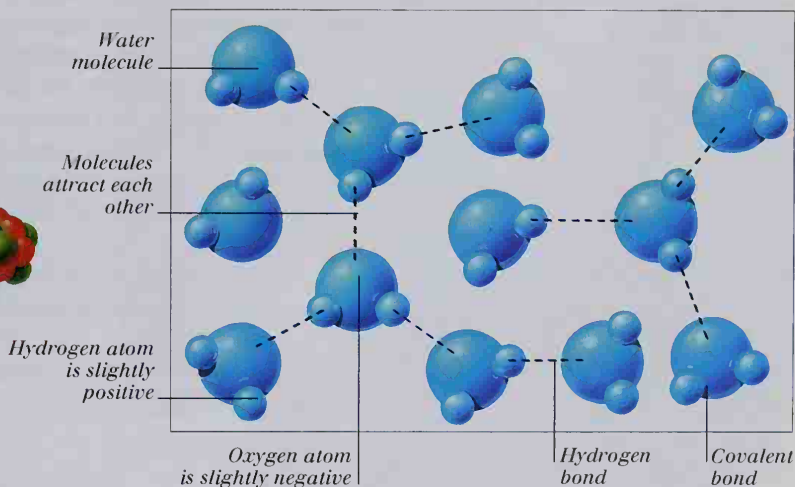

SODIUM CHLORIDE

A macromolecule of sodium chloride forms when sodium cations and chloride anions bond together. Ions are arranged in the macromolecule in a regular pattern, forming a crystal.

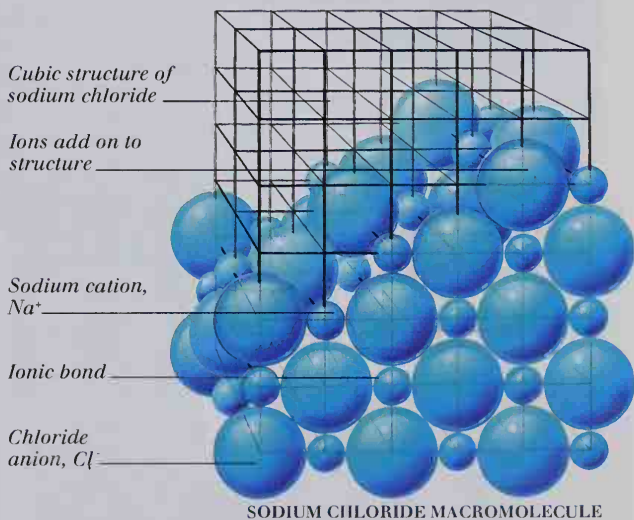

AN EXAMPLE OF COVALENT BONDING

1. NEUTRAL ATOMS OF HYDROGEN AND FLUORINE

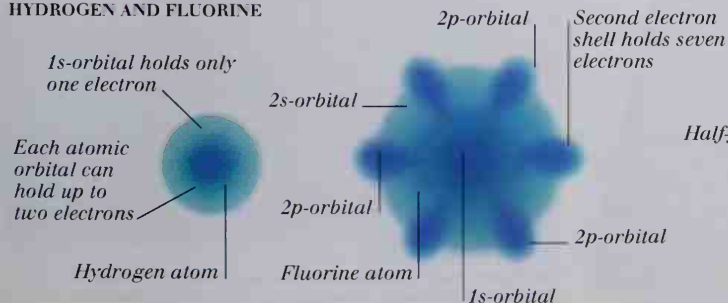

2. HYDROGEN FLUORIDE MOLECULE

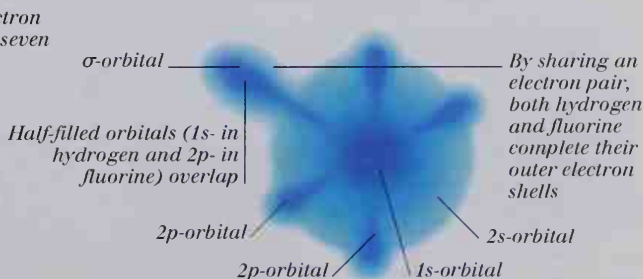

Chemical reactions

IN A CHEMICAL REACTION, THE ATOMS or ions of the reactants are rearranged to give products with different chemical and physical properties. For example, solutions of lead nitrate and potassium iodide react to produce a solid precipitate. Many reactions are reversible. Brown nitrogen dioxide gas decomposes at high temperatures to form a colorless mixture of oxygen and nitrogen monoxide. As the mixture cools, nitrogen dioxide forms again. The reactants and products are said to be in an equilibrium, the position of which depends on the temperature. Reactant and product concentrations may also affect the equilibrium. Reaction rates depend upon a number of factors, including temperature and concentration. Marble and dilute acid react together more rapidly if the marble is powdered to give it a greater surface area. During a chemical reaction, matter is neither created nor destroyed, only changed from one form to another – so the total mass of the products always equals the mass of the reactants.

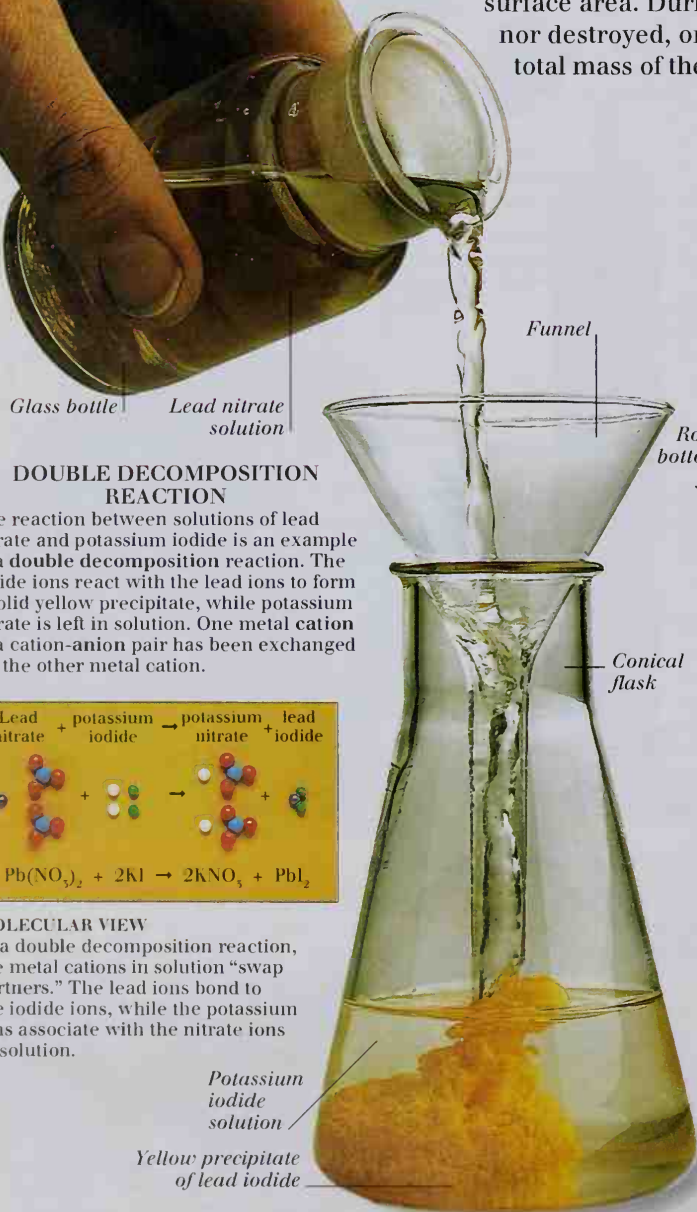

DOUBLE DECOMPOSITION REACTION

The reaction between solutions of lead nitrate and potassium iodide is an example of a double decomposition reaction. The iodide ions react with the lead ions to form a solid yellow precipitate, while potassium nitrate is left in solution. One metal cation of a cation-anion pair has been exchanged for the other metal cation.

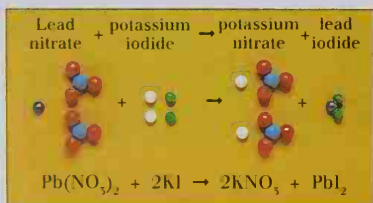

MOLECULAR VIEW

In a double decomposition reaction, the metal cations in solution “swap partners.” The lead ions bond to the iodide ions, while the potassium ions associate with the nitrate ions in solution.

EQUILIBRIUM AFFECTED BY TEMPERATURE

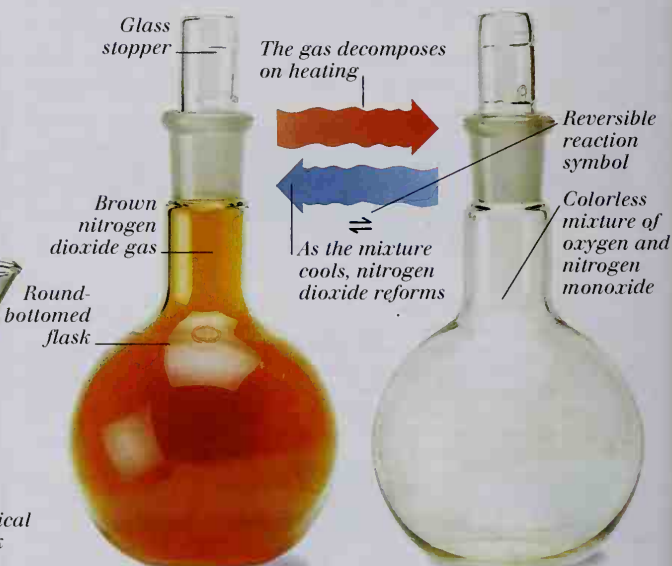

NITROGEN DIOXIDE, NITROGEN MONOXIDE, AND OXYGEN
The flask on the left contains nitrogen dioxide gas. At temperatures above 140°C (284°F), the gas begins to decompose, forming oxygen and nitrogen monoxide. Below this temperature, the equilibrium is pushed the other way and the reaction is reversed.

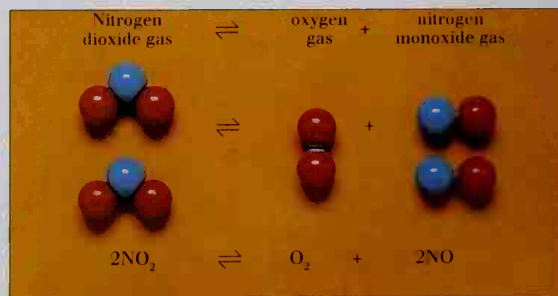

MOLECULAR VIEW

Nitrogen dioxide molecules are in equilibrium with diatomic molecules of oxygen and nitrogen monoxide.

EQUILIBRIUM AFFECTED BY CONCENTRATION

COBALT AND CHLORIDE IONS

A pink solution of a cobalt(II) salt contains cobalt ions, Co^{2+} . When concentrated hydrochloric acid is added to the solution, chloride ions, Cl^- , cluster around the cobalt ions, forming a **complex ion**, CoCl_4^{2-} , in a reversible reaction. The presence of this ion gives the solution a blue color. Adding more acid pushes the equilibrium position over toward the product – the complex ion. If the concentration of chloride ions is reduced by adding water, the pink color returns. The addition of water pushes the equilibrium position back toward the reactants – the simple cobalt(II) and chloride ions.

COBALT(II) SALT SOLUTION



Test tube

Cobalt ions, Co^{2+} , give the solution a pink color

Concentrated hydrochloric acid added

Complex ions, CoCl_4^{2-} , turn solution blue

ADDITION OF ACID



Dropper

On addition of more acid, the solution turns completely blue

COMPLEX ION SOLUTION



Adding more water reverses the reaction

Water reduces chloride ion concentration

Pink color returns as cobalt ions reform

Complex ions begin to decompose

ADDITION OF WATER



MARBLE CHIPS

Marble is one form of the ionic compound, calcium carbonate, CaCO_3 . Relatively few of the ions making up large chips of marble (below) are found on the chip surfaces – most of the ions are within the chips.



Marble chips

SURFACE AREA OF REACTANT

When dilute sulfuric acid reacts with marble (right), carbon dioxide gas is produced. If powdered marble is used (far right), more ions come into contact with the acid, and the reaction proceeds more rapidly.

Dilute acid

Coarse marble chips

RATE OF REACTION

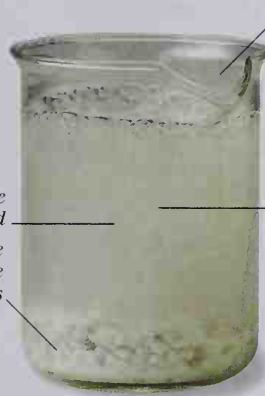

BEAKER WITH CHIPS

250 ml beaker

Carbon dioxide gas is produced at a faster rate

Bubbles of carbon dioxide gas are produced slowly

Fine powder of marble

Dilute acid

The mixture fizzes over the beaker

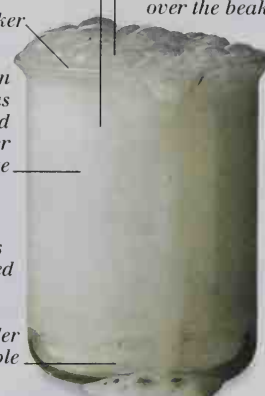

BEAKER WITH POWDER

CONSERVATION OF MASS

In every chemical reaction, mass is conserved. The reaction below is carried out in a sealed flask to prevent the escape of the gaseous product. An accurate chemical balance shows that there is no gain or loss of mass.



BEFORE THE REACTION

The reactants are weighed before the reaction. The balance is tared (or zeroed) with just the glassware, so that only the mass of the substances inside the glassware will be displayed.



AFTER THE REACTION

The reactants are mixed in the conical flask, and the flask is quickly sealed so that no reaction products can escape. The mass of products is identical to the mass of reactants.

Oxidation and reduction

IN MANY CHEMICAL REACTIONS (see pp. 80-81), **electrons** are transferred between the **atoms** or **ions** taking part. For example, when nitric acid reacts with copper metal, copper atoms lose electrons to become Cu^{2+} ions, while the acid gains electrons. An atom or ion that loses electrons (or gains oxygen) is said to undergo **oxidation**, while an atom or ion that gains electrons (or loses oxygen) undergoes **reduction**. Reactions that involve oxidation and reduction are called **redox reactions**. When an atom or ion is oxidized or reduced, its **oxidation number** changes by the number of electrons transferred. The oxidation number of any atom is 0 (zero), while that of an **element** in a **compound** is given by Roman numerals or by the amount of charge on its ions. For example, iron exists as iron(II) ions, Fe^{2+} , in rust, where it has an oxidation number of +2. An older definition of oxidation was combination with oxygen, as happens in **burning** reactions.

Concentrated nitric acid

Glass tap controls flow of nitric acid into the flask

Separating funnel

OXIDATION OF COPPER BY NITRIC ACID

Gas is evolved as reaction takes place

Rubber stopper

Clamp

Pieces of copper metal

A REDOX REACTION
When nitric acid and copper react, each copper atom loses two electrons and is oxidized to copper(II), or Cu^{2+} . Nitric acid, in which nitrogen has an oxidation number of +5, is reduced to nitrogen dioxide, NO_2 , also known as nitrogen(IV) oxide, in which nitrogen has an oxidation number of +4.

Round-bottomed flask

Brown nitrogen dioxide gas

Glass delivery tube

Gas jar

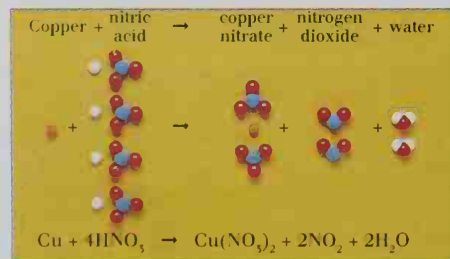

MOLECULAR MODEL OF REACTION

RUSTING OF IRON

The rusting of iron is an example of a redox reaction. Iron is oxidized to iron(II), with an oxidation number of +2, when it reacts with water and oxygen. The resulting compound, known as rust, is hydrated iron oxide. The tubes below show that both water and oxygen are needed for rust to form.

Oil prevents oxygen dissolving from the air

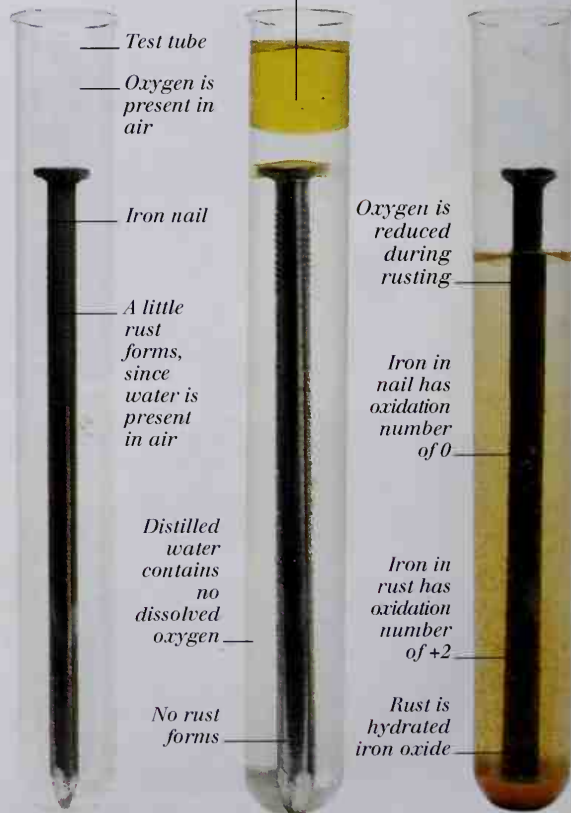

AIR, NO WATER

WATER, NO AIR

AIR AND WATER

COMBUSTION REACTION

All combustion reactions are redox reactions. Combustion, or burning, is defined as the rapid **exothermic** combination of a substance with oxygen. Candle wax is a **mixture of hydrocarbons**, mainly the **alkane** $C_{18}H_{38}$. Oxygen combines with the carbon atoms present to form carbon dioxide, and with the hydrogen atoms to form water.

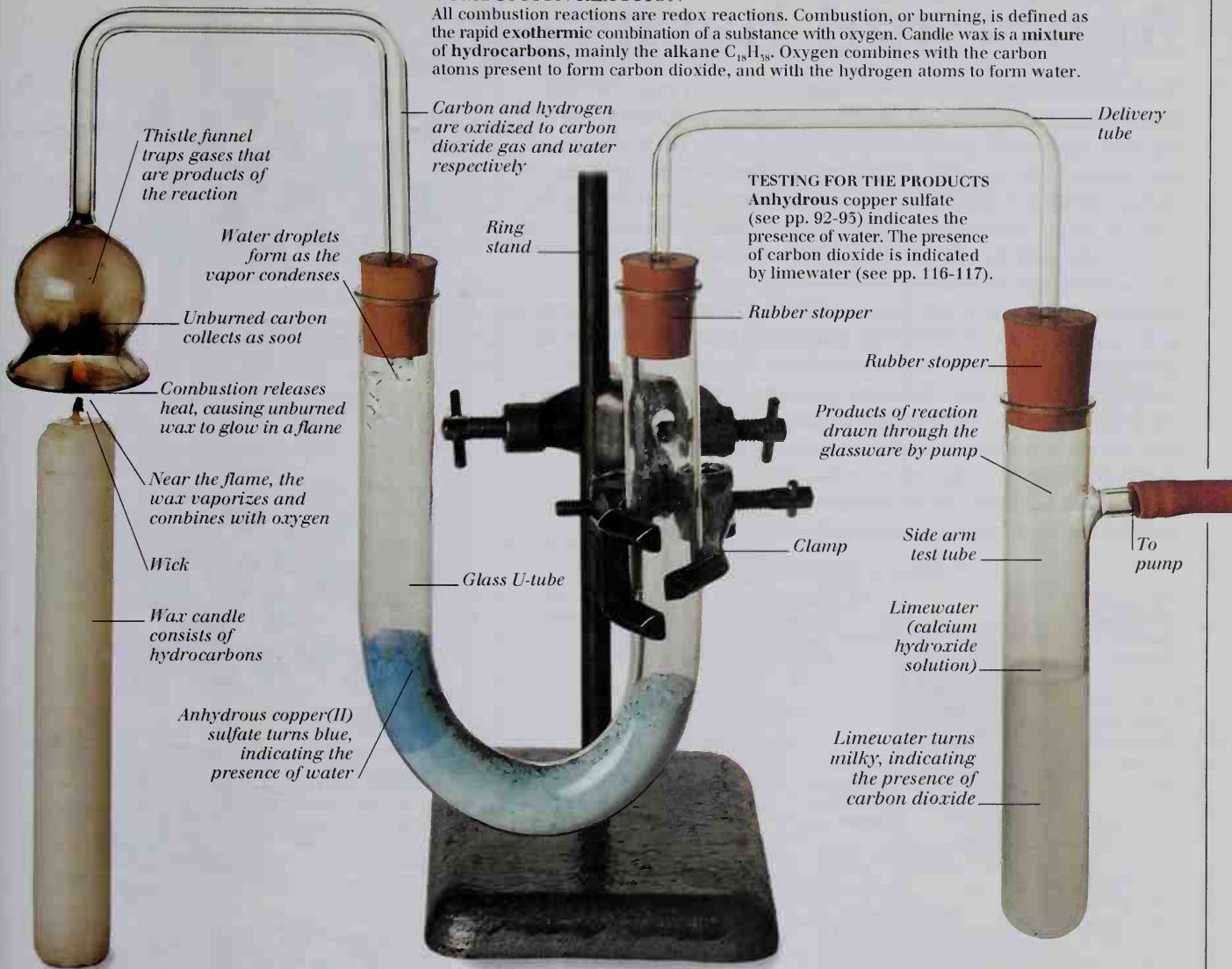

OXIDATION AS TRANSFER OF ELECTRONS

In many redox reactions, electrons are physically transferred from one atom to another, as shown.

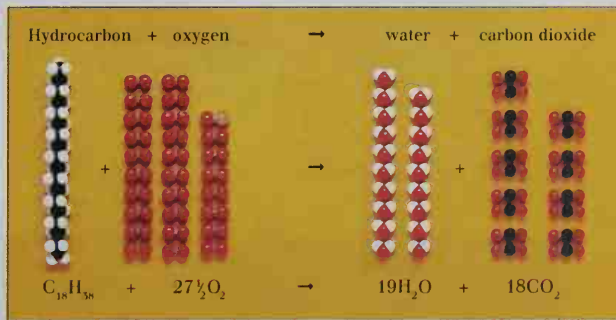
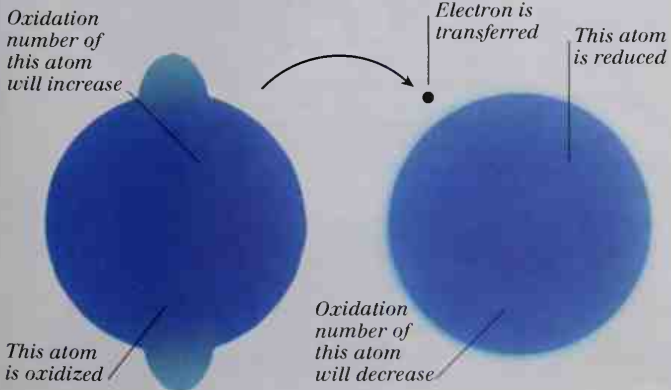

MOLECULAR MODEL OF REACTION

Two molecules of the hydrocarbon $C_{18}H_{38}$ react with 55 oxygen molecules, producing 38 molecules of water and 36 of carbon dioxide. Half of these amounts have been shown above.

Acids and bases

ACID IS A COMMON WORD in everyday use, but it has a precise definition in chemistry. An acid is defined as a molecule or an ion that can donate protons, or hydrogen ions, H^+ . A base is a substance, often an oxide or hydroxide, that accepts protons, and an alkali is a base that is water soluble. Some substances, such as water, can act as either acids or bases, depending on the other substances present. Acids and bases undergo characteristic reactions together, usually in aqueous solution, producing a salt (see pp. 86-87) and water. In solution, acid-base reactions involve the transfer of hydronium ions or hydrated protons, H_3O^+ . These ions form, for example, when hydrogen chloride gas dissolves in water. The pH scale gives the concentration of hydronium ions in solution. As pH falls below 7, a solution becomes more acidic. Conversely, as pH rises above 7, the solution becomes more alkaline. The pH of a solution can be estimated using pigments called indicators, or measured accurately with a pH meter.

UNIVERSAL INDICATOR PAPER

This sample of hydrochloric acid has a pH of about 1

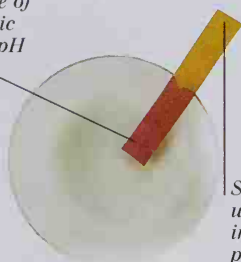

HYDROCHLORIC ACID

This ammonia-based domestic cleaner has a pH of about 10



DOMESTIC CLEANER

Pure distilled water has a pH of 7 and is neutral

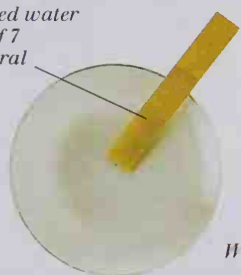

DISTILLED WATER

The pH of liquid soap, a weak alkali, is about 8



LIQUID SOAP

Watch glass



Electronic probe measures concentration of H_3O^+ ions
— Bottle of test solution

MEASURING pH

This digital pH meter accurately measures hydronium ion concentration. Such meters are often used to find the pH of colored solutions, which could mask the true color of indicators.

THE MEANING OF pH

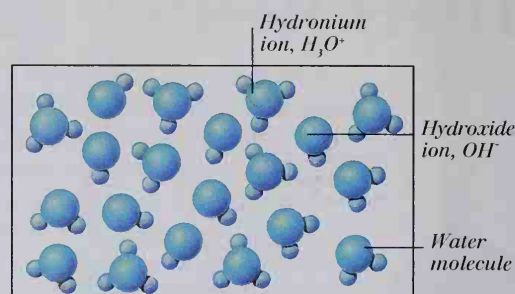

PURE WATER (NEUTRAL)

Some of the molecules of liquid water break up, or dissociate, forming hydroxide ions, OH^- , and hydrogen ions, H^+ , that become hydrated, H_3O^+ . In one liter of pure water at $20^\circ C$, there are 10^7 moles (see pp. 72-73) of each type of ion. This gives a pH value of 7 (neutral) for pure water.

Hydronium ion

Concentration of hydronium ions lower than in pure water

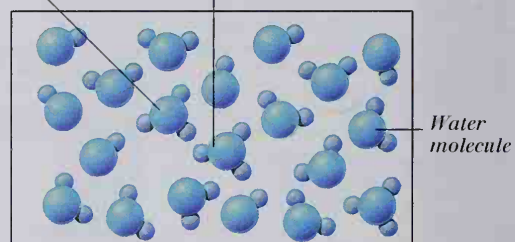

ALKALINE SOLUTION

When an alkali is added to water, it removes protons, H^+ , from some of the hydronium ions, H_3O^+ , present, forming more water molecules. The lower the concentration of H_3O^+ , the higher the pH. Typically, a weakly alkaline solution has a pH of 10, and a strongly alkaline solution has a pH of 14.

Hydronium ion

Concentration of hydronium ions higher than in pure water

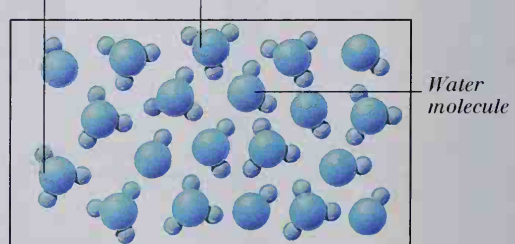

ACIDIC SOLUTION

When an acid is dissolved in water, it donates protons, H^+ , to water molecules, H_2O , making more hydronium ions, H_3O^+ . Water thus acts as a base. The concentration of hydronium ions increases, and the pH decreases.



ACID ON A HYDROGENCARBONATE

Acids react with hydrogencarbonates and carbonates to produce carbon dioxide gas. The reaction shown is between vinegar, an acid, and sodium hydrogencarbonate, NaHCO_3 , also known as sodium bicarbonate.

NEUTRALIZATION OF AN ACID

When acid and alkaline solutions are mixed together in the correct proportions, they neutralize each other, giving a solution of pH 7. This reaction is used in a procedure called **titration**, shown below. Titrations are often used to calculate the concentration of a solution.

The concentration of the alkali can be calculated from the volume of acid solution used in the neutralization

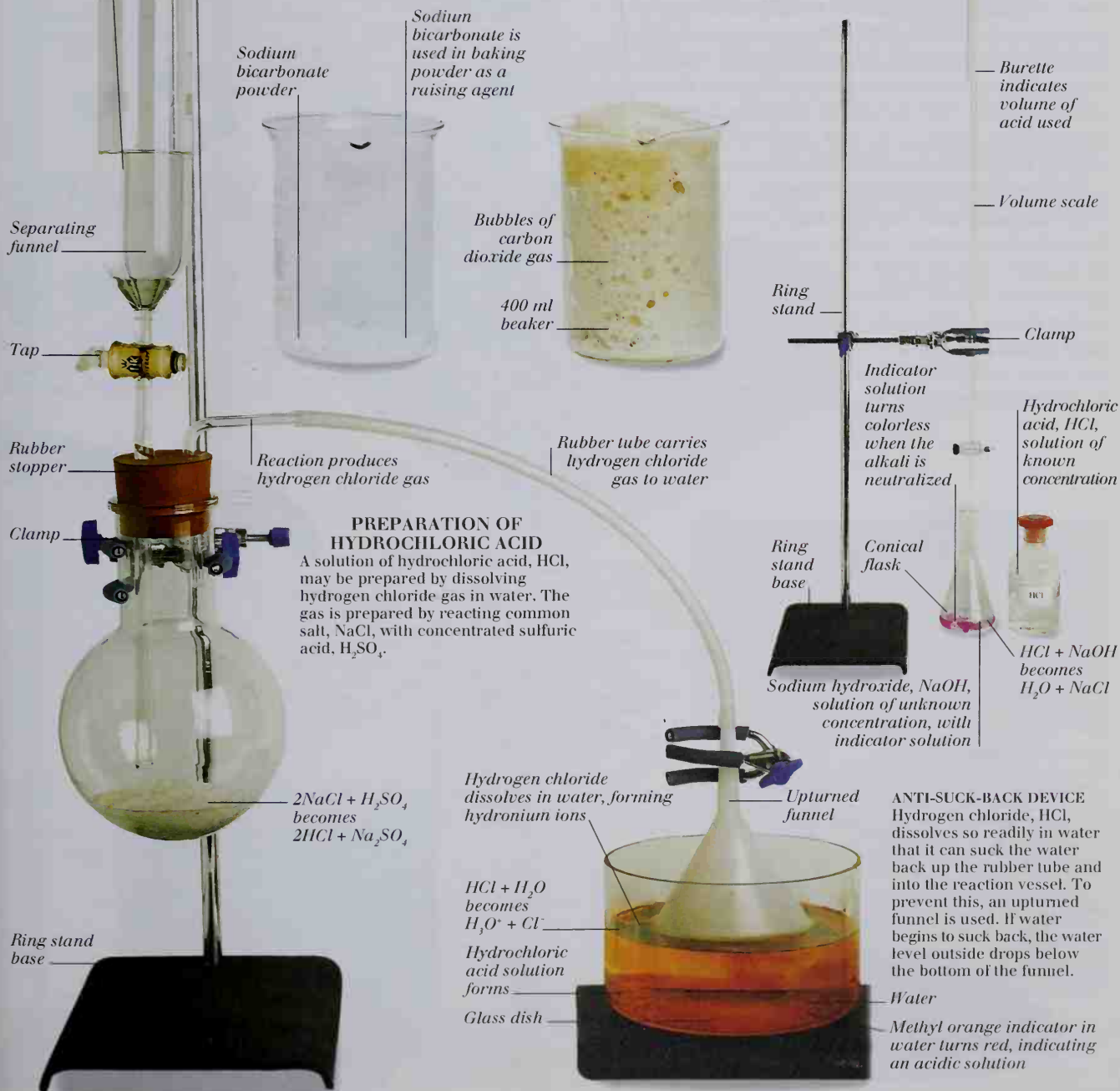

PREPARATION OF HYDROCHLORIC ACID

A solution of hydrochloric acid, HCl , may be prepared by dissolving hydrogen chloride gas in water. The gas is prepared by reacting common salt, NaCl , with concentrated sulfuric acid, H_2SO_4 .

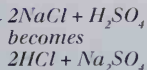

Hydrogen chloride dissolves in water, forming hydronium ions

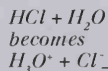

Hydrochloric acid solution forms

Glass dish

ANTI-SUCK-BACK DEVICE
Hydrogen chloride, HCl , dissolves so readily in water that it can suck the water back up the rubber tube and into the reaction vessel. To prevent this, an upturned funnel is used. If water begins to suck back, the water level outside drops below the bottom of the funnel.

Water
Methyl orange indicator in water turns red, indicating an acidic solution

Salts

WHENEVER AN ACID AND A BASE **neutralize** each other (see pp. 84-85), the **products** of the reaction always include a **salt**. A salt is a **compound** that consists of **cations** (positive ions) and **anions** (negative ions). The cation is usually a metal ion, such as the sodium ion, Na^+ . The anion can be a nonmetal such as the chloride ion, Cl^- , although more often it is a unit called a **radical**. This is a combination of nonmetals that remains unchanged during most reactions. So, for example, when copper(II) oxide is added to sulfuric acid, the sulfate radical (SO_4^{2-}) becomes associated with copper ions, forming the salt copper(II) sulfate, CuSO_4 . Salts are very widespread compounds – the most familiar being sodium chloride, or common salt. Mineral water contains salts, which are formed when slightly acidic rainwater dissolves rocks such as limestone. Water that contains large amounts of certain dissolved salts is called hard water (see pp. 100-101). A class of salts called acid salts contains a positive hydrogen ion in addition to the usual metal cation. Acid salts can be prepared by careful **titration** of an acid and a base.

FORMATION OF SALTS

In the generalized equations below, an acid reacts with three typical bases – a hydroxide, an oxide, and a carbonate. A cation from the base combines with the acid's anion or negative radical, displacing the hydrogen ion to form a salt.

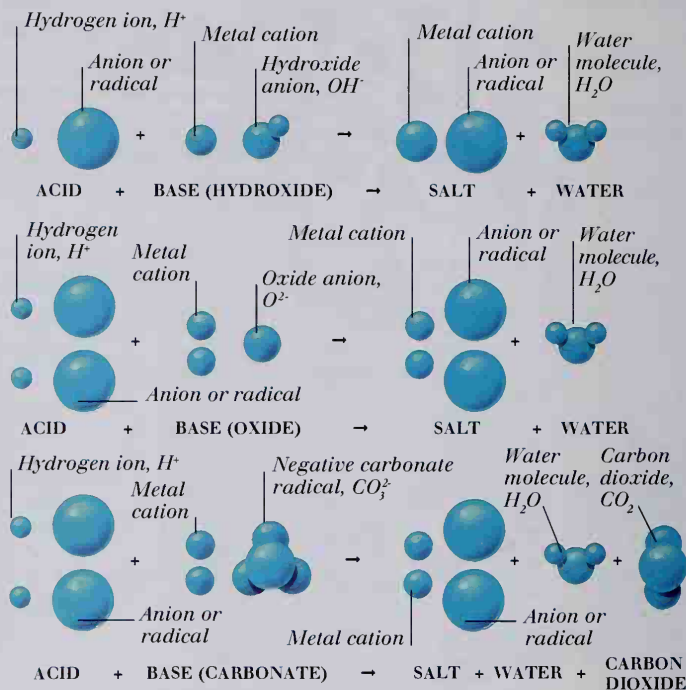

COPPER(II) SULFATE

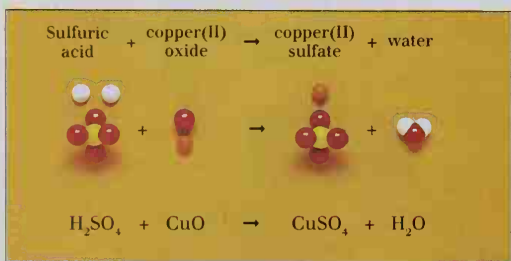

MOLECULAR VIEW

When the base copper(II) oxide reacts with sulfuric acid, copper(II) ions take the place of the hydrogen in the acid. The salt formed is therefore copper(II) sulfate. Water is the other product. The sulfate ion is a radical.

COPPER(II) OXIDE AND SULFURIC ACID
 Copper(II) oxide, a black powder, is a base. When added to colorless dilute sulfuric acid, a neutralization reaction occurs. Hydrogen from the acid and oxygen from copper(II) oxide form water, while copper ions and the sulfate radical form the salt copper(II) sulfate.

Black copper(II) oxide

Spatula

250 ml beaker

Dilute sulphuric acid

Salt forms as copper(II) oxide neutralizes acid

Copper(II) oxide powder

Watch glass

Blue solution contains copper ions, Cu^{2+}

DISSOLVED SALTS IN MINERAL WATER

Mineral water contains dissolved solids

Bubbles of steam form as the water boils
Water has been boiled away

Solid residue of salts

Natural salts from rocks

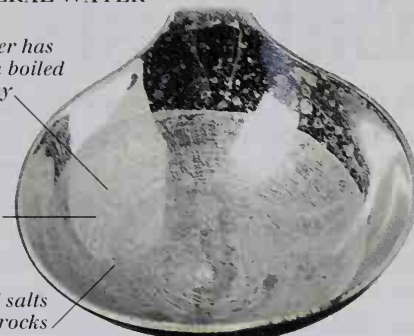
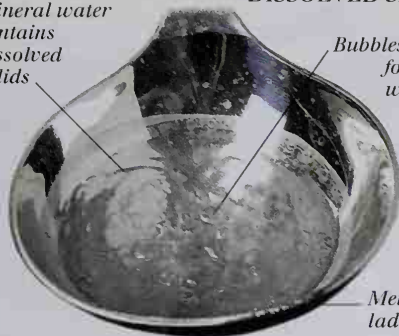

Burette

Metal ladle

BOILING MINERAL WATER

Nearly all salts are ionic, and dissolve to a certain extent in water. Mineral water contains small amounts of dissolved salts. They are normally invisible, because they exist as individual ions and radicals.

RESIDUE AFTER BOILING

When mineral water is boiled, a small amount of solid residue is formed. This consists of salts. Pure water would leave no residue. The salts in mineral water originate in rocks over which rainwater passes.

ACID ON LIMESTONE

Limestone is one form of calcium carbonate, CaCO_3 . It dissolves in acid to form a calcium salt. Carbon dioxide is evolved during the reaction, and geologists sometimes use this as a test for a carbonate rock (see pp. 116-117).



Block of limestone rock

Effervescence (fizzing) as rock dissolves

Bubbles of carbon dioxide gas

Calcium salt forms

Clamp

Solution of sodium hydroxide

Ring stand

ACID SALTS

In an acid salt, only some of the hydrogen ions of the acid are replaced by other cations. Here, sulfuric acid is neutralized by the base sodium hydroxide. The volume of base used is noted. In a separate flask, only half this volume of base is added to the same volume of acid, forming the acid salt sodium hydrogensulfate.

Watch glass
Translucent crystals formed by slow evaporation of acid salt solution

Sodium hydrogensulfate is an acid salt

CRYSTALS OF SODIUM HYDROGENSULFATE

Tap

Mixture of sulfuric acid, sodium hydroxide, and an indicator

Indicator turns white as the acid is neutralized

Acid is half-neutralized

Flask

500 ml beaker

Sulfuric acid of unknown concentration

Sodium hydroxide solution of known concentration

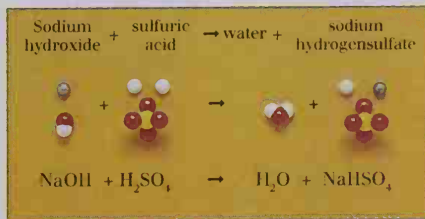

MOLECULAR VIEW
Each unit of sulfuric acid has two hydrogen ions. Adding the right amount of sodium hydroxide removes only one of these ions.

Catalysts

A **CATALYST** IS A SUBSTANCE that increases the **rate** at which a reaction takes place but is unchanged itself at the end of the reaction. Certain **catalysts** are used up in one stage of a reaction and regenerated at a later stage. Light is sometimes considered to be a catalyst – although it is not a substance – because it speeds up certain reactions. This process is referred to as **photocatalysis** and is very important in photography and in **photosynthesis** (see pp. 100-101). Often, catalysts simply provide a suitable surface upon which the reaction can take place. Such surface catalysis often involves **transition metals**, such as iron or nickel. Surface catalysis occurs in catalytic converters in automobiles, which speed up reactions that change harmful pollutant gases into less harmful ones. **Enzymes** are biological catalysts and are nearly all **proteins**. They catalyze reactions in living organisms. For example, an enzyme called **ptyalin** in saliva helps to digest or break down starch in food to make sugars that can be readily absorbed by the body. Enzymes are also important in turning sugar into alcohol during fermentation.

PHOTOCATALYSIS

Light can promote, or speed up, a reaction. Here, both tubes contain a yellow precipitate of silver bromide (see pp. 116-117). For a period of about ten minutes, one of the tubes has been left in a dark cupboard while the other has been left in the light. The light has caused silver ions to become atoms of silver. Photographic films contain tiny granules of silver halides, which produce silver on the negative wherever it is hit by light.

Test tube

Precipitate of silver bromide

Only slight brown color

Precipitate of silver bromide has turned black-brown

Test tube

Light speeds up reaction

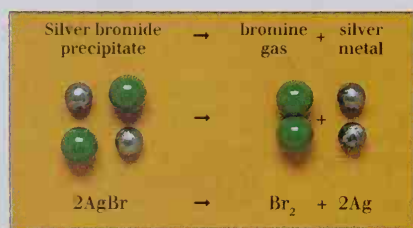

MOLECULAR MODEL OF REACTION

The reaction proceeds more slowly in the absence of light

Black-brown color caused by silver metal
Bromine produced by reaction dissolves in water

TUBE LEFT IN DARKNESS

TUBE LEFT IN LIGHT

CATALYSIS AT A SURFACE

Reactant A is a diatomic molecule

Reactant B approaches surface

Surface atoms of catalyst



REACTANTS APPROACH SURFACE
In this reaction, one of the reactants is a diatomic molecule that must be split before it will react.

Reactant bonds weakly to surface atom

Atom of diatomic molecule

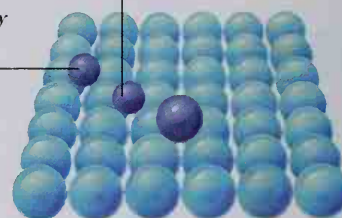

REACTANTS BOND TO SURFACE
The reactants form weak bonds with the surface atoms. As the diatomic molecule bonds, it breaks into two individual atoms.

Reactants migrate across surface

Reaction occurs at surface

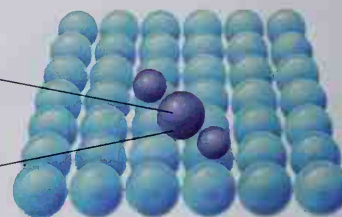

REACTION TAKES PLACE
The reactants move, or migrate, across the surface. When they meet, the reaction takes place. The surface is unchanged.

Product of reaction

Catalyst surface is unchanged

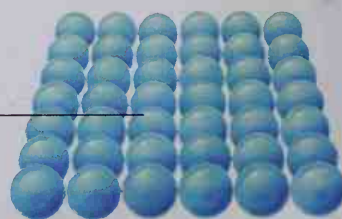

PRODUCT LEAVES SURFACE
The reaction product leaves the surface, to which it was very weakly bonded, and the reaction is complete.

EXAMPLES OF SURFACE CATALYSTS

CATALYTIC CONVERTER
 Many automobiles are fitted with a catalytic converter, as part of the exhaust system. Inside is a fine honeycomb structure coated with catalysts. Harmful carbon monoxide, nitrogen oxides, and unburned hydrocarbons are converted into carbon dioxide and harmless water and nitrogen.

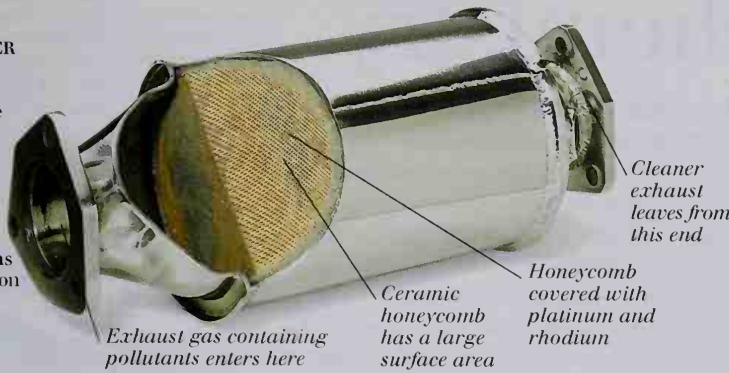

250 ml beaker
 Bubbles of carbon dioxide coming out of solution

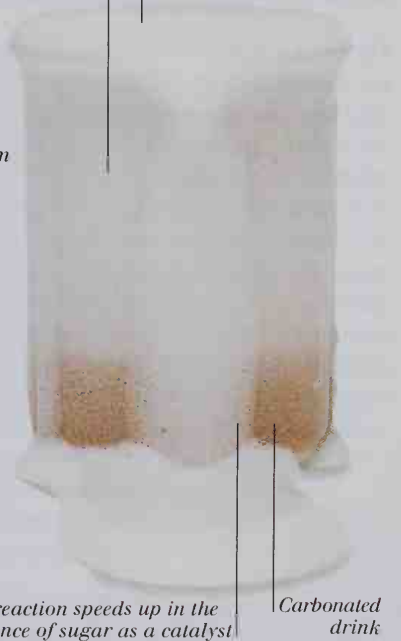

SUGAR AS A SURFACE CATALYST
 Carbonated drinks contain carbon dioxide gas dissolved in water. The carbon dioxide normally comes out of solution quite slowly. This reaction speeds up at a catalytic surface, such as that of sugar.

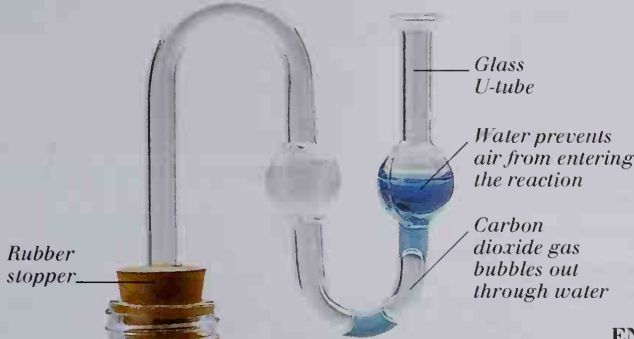

ENZYMES

FERMENTATION

Glucose and fructose are sugars found in fruit such as grapes. These sugars are turned into alcohol (ethanol) by an enzyme called zymase in yeast. The zymase catalyzes the decomposition of sugars into alcohol. Carbon dioxide is also produced.

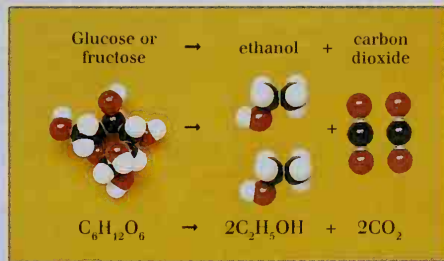

MOLECULAR MODEL OF REACTION



Grape juice, yeast, water, and extra sugar

Yeast contains the enzyme zymase

Alcohol is produced

Potato contains starch

Starch on this side has been broken down by amylase

Starch on this side remains

Iodine solution turns black, indicating the presence of starch

Iodine solution remains brown, indicating little starch

DIGESTION OF STARCH

Enzymes called amylases break down starch, forming sugars. Here, one side of a potato has been covered in saliva, which contains an amylase called ptyalin. The presence of starch can be indicated using an iodine solution.

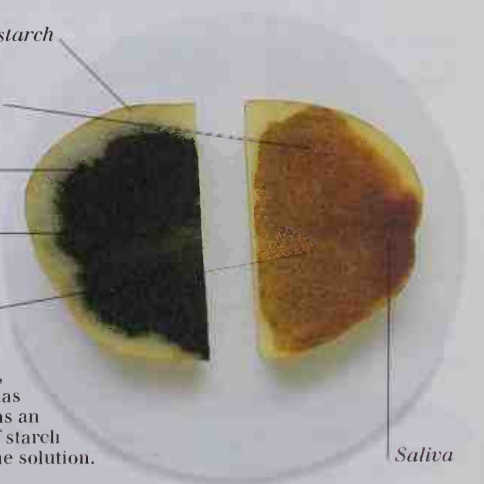

Heat in chemistry

HEAT IS A FORM OF ENERGY that a substance possesses due to the movement or vibration of its **atoms, molecules, or ions**.

The **temperature** of a substance is a measure of the average heat (or **kinetic**) energy of its particles, and is a factor in determining whether the substance is solid, liquid, or gas. Energy changes are involved in all reactions. For example, light energy (see pp. 100-101) and electrical energy (see pp. 96-97) can make reactions occur or can be released as a result of reactions. Heat energy is taken in or released by most reactions. Some reactions, such as the **burning** of wood, need an initial input of energy, called **activation energy**, in order for them to occur. Once established, however, the burning reaction releases heat energy to the surroundings – it is an **exothermic** reaction. Other reactions take heat from their surroundings and are called **endothermic** reactions. The thermite reaction, in which aluminum metal reacts with a metal oxide, is so exothermic that the heat released can be used to weld metals.

LIQUID CHLORINE

A gas becomes a liquid if cooled below its boiling point. Here, chlorine gas has been pumped into a test tube. Heat energy is then removed from the gas by cooling the tube in dry ice.

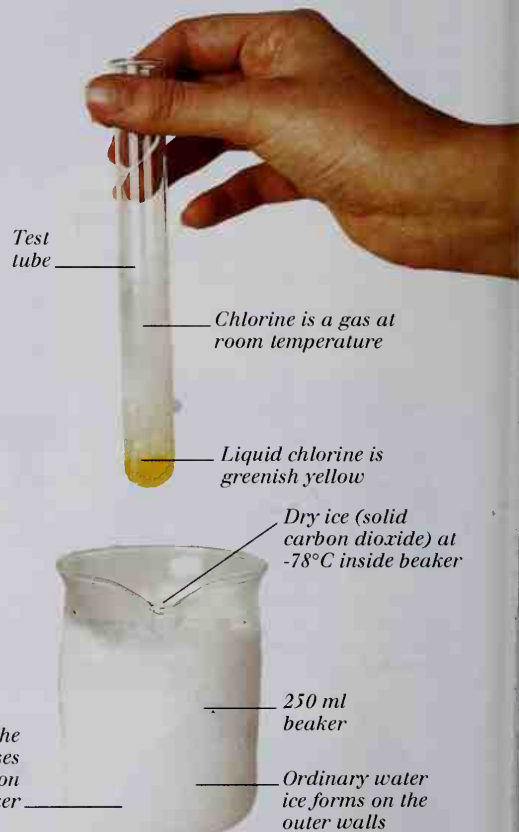

ACTIVATION ENERGY

Friction between a match head and a rough surface produces heat. This heat provides the energy that the chemicals in the match head need to start reacting. The heat released in this reaction begins the burning of the wood.

Match rubbed against rough surface
Burning wood combines with oxygen from the air
Match head contains phosphorus

Water from the air condenses and freezes on the cold beaker

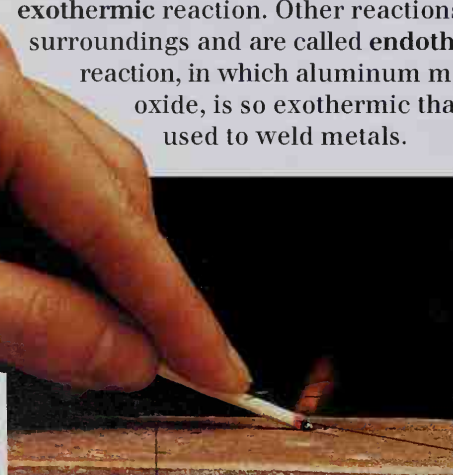

Rough surface

EXOTHERMIC AND ENDOTHERMIC REACTIONS

EXOTHERMIC REACTION, $\text{CaCl}_2 \rightarrow \text{Ca}^{2+} + 2\text{Cl}^-$
Compounds contain a certain amount of energy. If the energy of the products of a reaction is less than that of the reactants, then heat will be released to the surroundings. The reaction is described as exothermic. When calcium chloride dissolves in water, an exothermic reaction takes place.

Thermometer reads 21.5°C , a few degrees above room temperature

ENDOTHERMIC REACTION, $\text{NH}_4\text{NO}_3 \rightarrow \text{NH}_4^+ + \text{NO}_3^-$
If the energy of the products of a reaction is more than that of the reactants, then heat will be taken from the surroundings. The reaction is described as endothermic. An endothermic reaction occurs when ammonium nitrate is dissolved in water.

Thermometer reads 13.8°C , a few degrees below room temperature

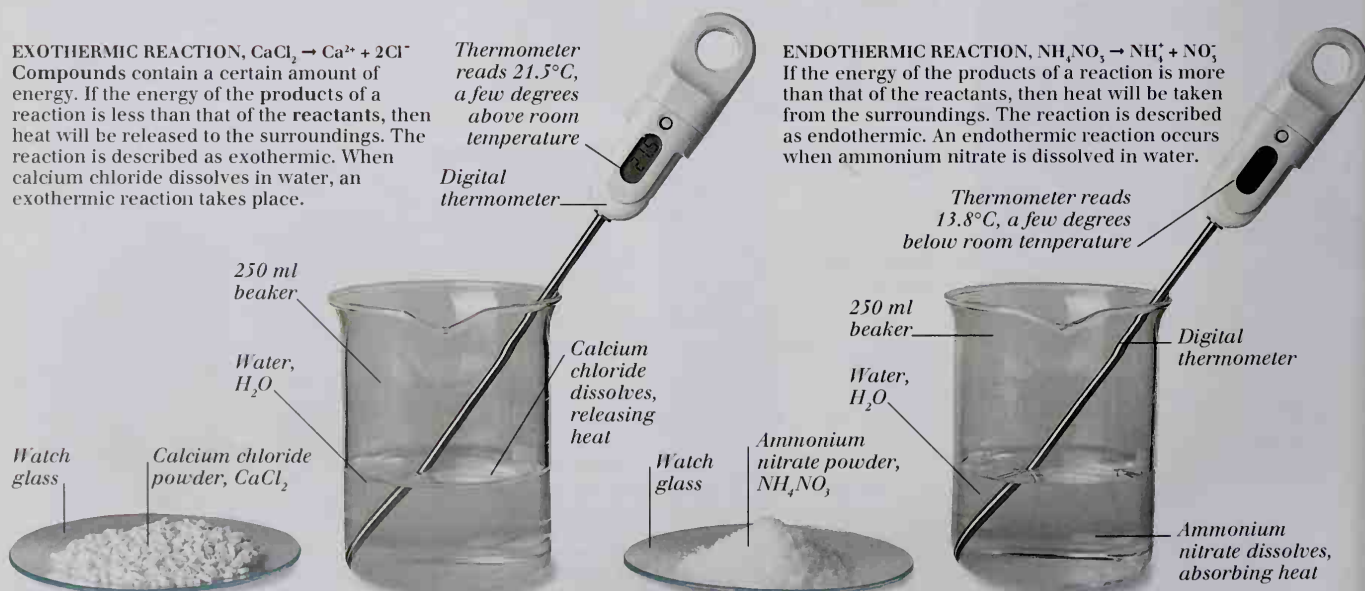

THERMITE REACTION

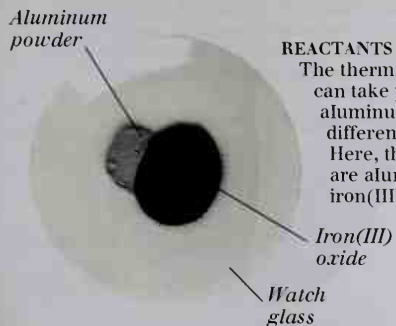

REACTANTS

The thermite reaction can take place between aluminum and many different metal oxides. Here, the reactants are aluminum and iron(III) oxide.

Thick smoke consists of small particles of reaction products

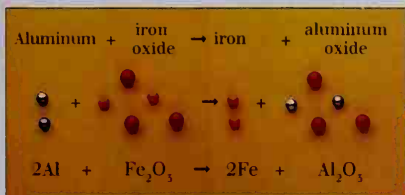

MOLECULAR MODEL OF REACTION

THERMITE WELDING

The tremendous amount of heat released by the thermite reaction is put to good use in welding railway tracks. Iron oxide is used, yielding molten iron as one of the reaction products. The molten iron helps to make the weld.



Pot containing reactants

Molten iron flows into gap to make weld

THE REACTION
When aluminum reacts with iron(III) oxide, aluminum(III) oxide and iron are produced. Aluminum is a very reactive metal (see pp. 94-95) and has a greater affinity for oxygen than iron does. The reaction products have much less energy than the reactants, so the reaction of aluminum with iron(III) oxide is exothermic.

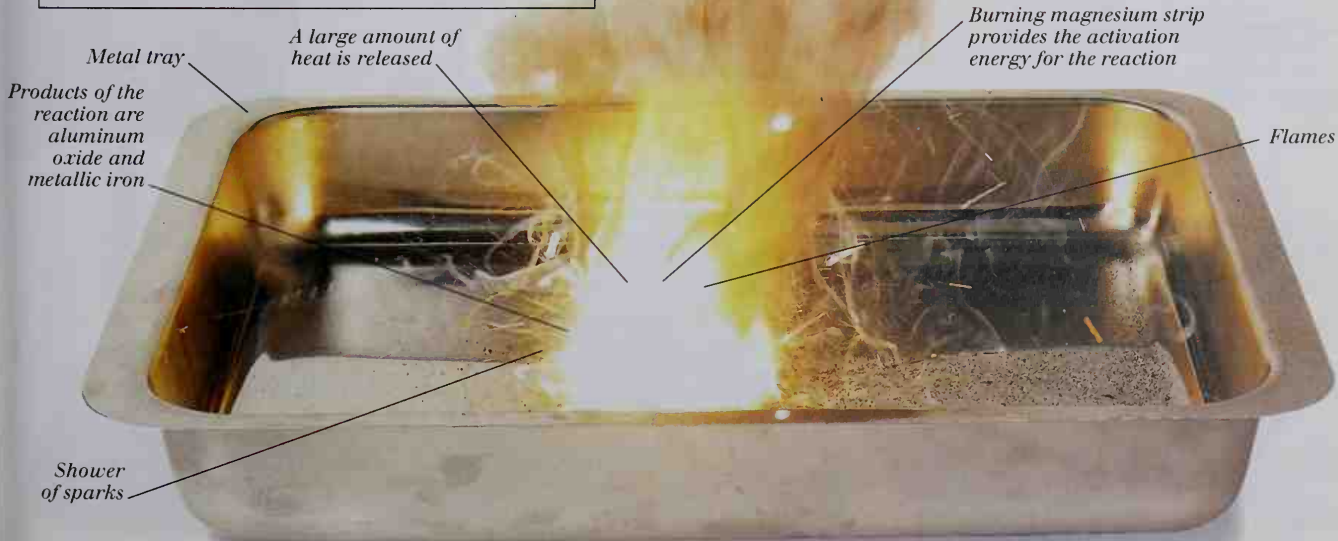

Metal tray

A large amount of heat is released

Burning magnesium strip provides the activation energy for the reaction

Flames

Products of the reaction are aluminum oxide and metallic iron

Shower of sparks

Water in chemistry

EACH MOLECULE OF WATER consists of two atoms of hydrogen bound to an oxygen atom. Water reacts physically and chemically with a wide range of elements and compounds. Many gases dissolve in water – in particular, ammonia dissolves very readily, as demonstrated by the fountain experiment. Some compounds, called **dehydrating agents**, have such a strong affinity for water that they can remove it from other substances. Concentrated sulfuric acid is so powerful a dehydrating agent that it can remove hydrogen and oxygen from certain compounds, making water where there was none before. Water is often held in crystals of other substances, and is then called **water of crystallization**. A compound can lose its water of crystallization during strong heating, and is then said to be **anhydrous**. Adding water to anhydrous crystals can restore the water of crystallization. Some compounds, described as **efflorescent**, have crystals that lose their water of crystallization to the air. Conversely, **hygroscopic** compounds have crystals that absorb water from the air. Desiccators often employ such compounds to dry other substances.

WATER OF CRYSTALLIZATION
Crystals containing water of crystallization are said to be hydrated. Heating a hydrated crystal causes it to lose water.



COPPER(II) SULFATE SOLUTION
Gently heating a solution of blue copper(II) sulfate evaporates the water, leaving behind blue crystals of hydrated copper(II) sulfate.

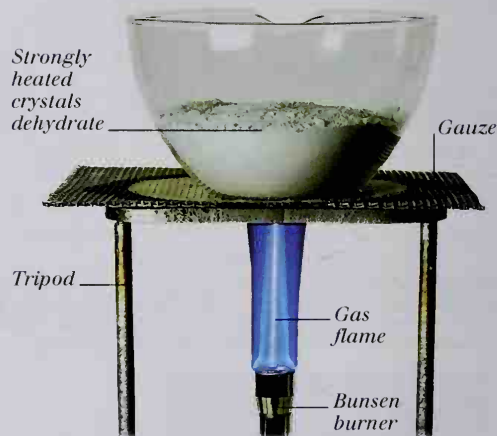

ANHYDROUS COPPER(II) SULFATE
Strongly heating the hydrated crystals drives off the water of crystallization, leaving a white powder of anhydrous copper(II) sulfate.

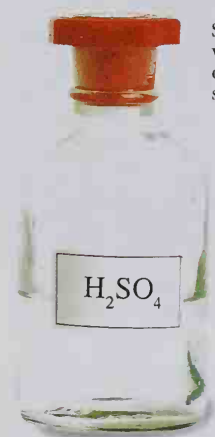

SULFURIC ACID AS A DEHYDRATING AGENT

Substances known as dehydrating agents can either simply remove water from a mixture, or remove hydrogen and oxygen from a compound in the ratio 2:1, the ratio found in water. Concentrated sulfuric acid is a very powerful dehydrating agent (below).

Sucrose molecule is made of two linked sugar units

Pure carbon

Hydrogen and oxygen form water

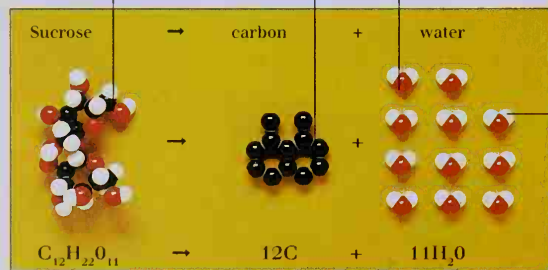

Each water molecule has two atoms of hydrogen and one of oxygen

MOLECULAR MODEL OF REACTION

Bulb
Dropper pipette containing water

HYDRATION
Adding water hydrates the white powder. A blue color appears, as hydrated copper(II) sulfate crystals form once more.

Hydrated copper(II) sulfate forms

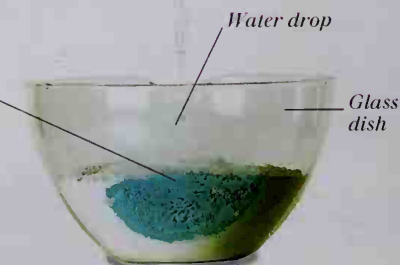

DEHYDRATION OF SUCROSE

Concentrated sulfuric acid removes 22 hydrogen atoms and 11 oxygen atoms from each molecule of sucrose, leaving only black carbon behind. The reaction evolves heat, enough to boil the water produced and form steam.

AMMONIA FOUNTAIN

Water is a good solvent – even many gases dissolve in it. Ammonia dissolves very readily in water, forming an **alkaline solution** (see pp. 84-85). This fountain experiment employs red litmus solution, an **indicator** that turns blue in the presence of an alkali.

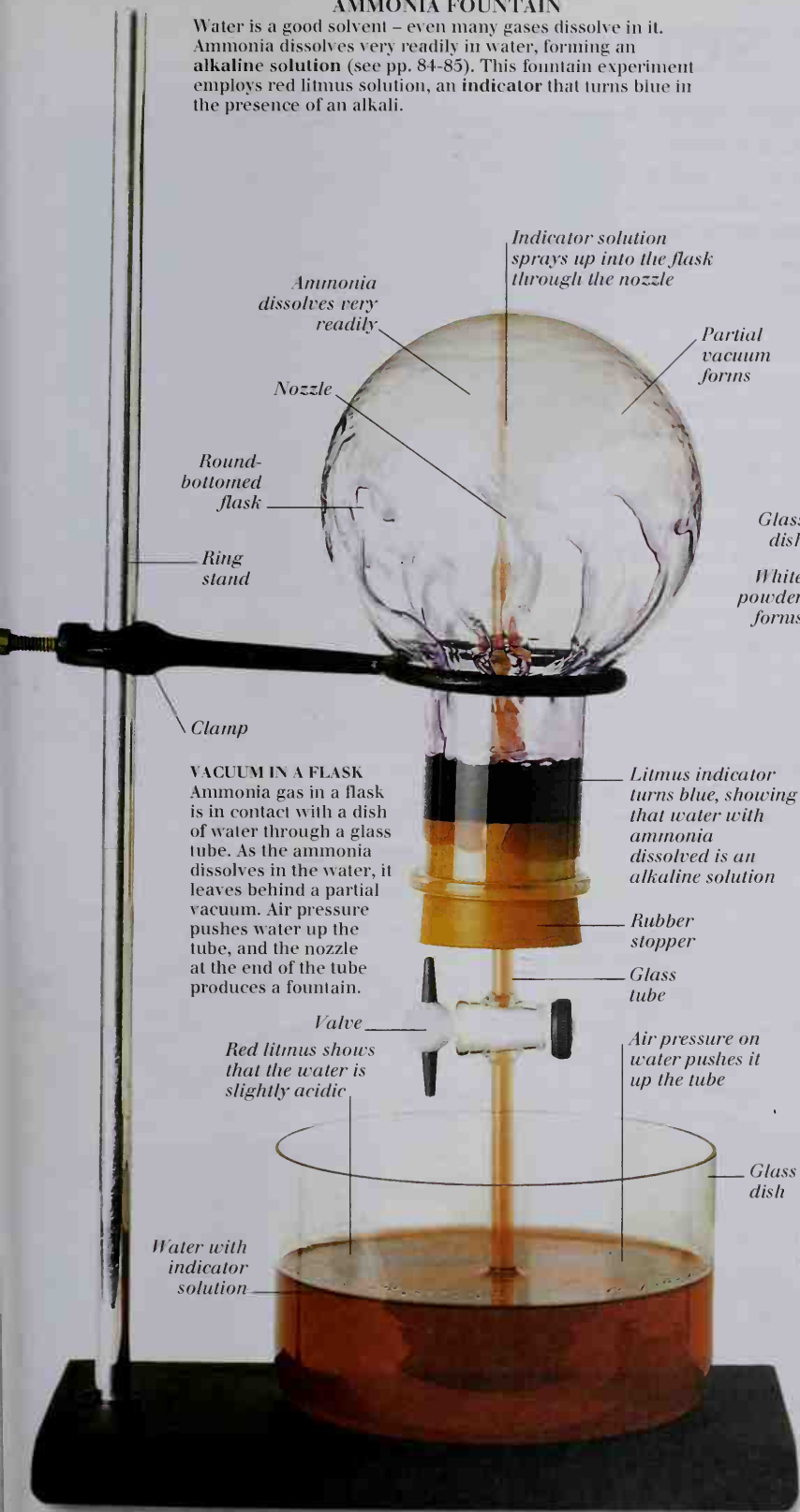

EFFLORESCENCE AND HYGROSCOPY

In these two processes, compounds lose or gain water of crystallization. Efflorescent compounds lose their water of crystallization to the air. Hygroscopic compounds gain water from the air.

Glass dish Sodium carbonate



SODIUM CARBONATE DECAHYDRATE
The white crystals of sodium carbonate decahydrate (washing soda) shown here are efflorescent. Two sodium ions and a carbonate ion are combined with ten molecules of water of crystallization to form sodium carbonate decahydrate, $\text{Na}_2\text{CO}_3 \cdot 10\text{H}_2\text{O}$.

Glass dish White powder forms



SODIUM CARBONATE AFTER EXPOSURE TO AIR

When left in the air, the sodium carbonate decahydrate crystals give up most of the water of crystallization associated with them. The resulting white powder, called a monohydrate, is visible here on the surface of the crystals.

DESICCATOR

Some substances need to be kept free of moisture. A desiccator is a device that removes moisture. It is usually a glass container with a desiccant, or drying agent, inside.



The activity series

ALL METAL ATOMS LOSE ELECTRONS fairly easily and become positive **ions**, or **cations**. The ease with which a metal loses electrons is a measure of its **reactivity**. Metals in groups 1 and 2 of the periodic table (see pp. 98-101), which have one and two outer electrons respectively, are usually the most reactive. Aluminum in group 3 is a reactive metal, but less so than calcium in group 2. Metals can be arranged in order of decreasing reactivity in a series known as the activity series. In this series, zinc is placed above copper, and copper above silver. Zinc metal is more reactive than copper and can displace copper ions from a **solution**. Similarly, copper displaces silver from solution. Electrons from the more reactive metal transfer to the less reactive metal ions in solution, resulting in the **deposition** of the less reactive metal. Because electron transfer occurs in these reactions, they are classified as **redox reactions**. The reactivity of a metal may be characterized in many ways – for example, by its reactions with **acids**. The different reactivities of metals have a practical application in the prevention of corrosion in underwater pipes.

ALUMINUM METAL

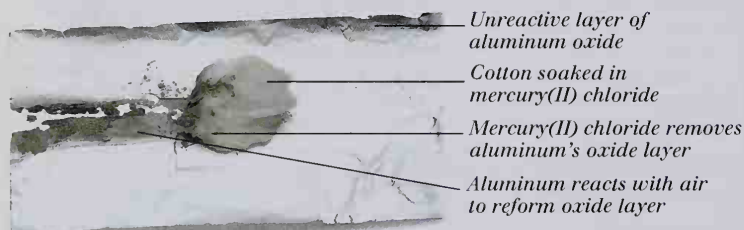

REMOVING THE OXIDE LAYER

Metallic aluminum, which is used to make kitchen foil and saucepans, seems unreactive. Actually, aluminum is quite high in the activity series. When pure aluminum is exposed to the air, a thin layer of unreactive aluminum oxide rapidly forms on the surfaces, preventing further reaction.



ZINC METAL



COPPER(II) SULFATE SOLUTION



ZINC(II) SULFATE SOLUTION AND METALLIC COPPER

TABLE OF METAL REACTIVITY

Metal	Air or oxygen on metal	Water on metal	Acids on metal	Metals on salts of other metals
K	Burn in air or oxygen	React with cold water (with decreasing ease)	Displace hydrogen from acids that are not oxidizing agents (with decreasing ease)	Displace a metal lower in the series from a solution of one of its salts
Na				
Ca				
Mg		React with steam when heated		
Al				
Zn				
Fe	Converted into the oxide by heating in air	No reaction with water or steam	React only with oxidizing acids	
Sn				
Pb				
Cu				
Hg	Unaffected by air or oxygen	No reaction with acids		
Ag				
Au				
Pt				

DISPLACEMENT OF COPPER(II) IONS BY ZINC METAL

A displacement reaction is one in which atoms or ions of one substance take the place of atoms or ions of another. Here, zinc loses electrons to copper ions and displaces copper from a blue solution of copper(II) sulfate. The products of this reaction are copper metal and colorless zinc(II) sulfate solution.

CATHODIC PROTECTION

Sacrificial tubing of more reactive metal Steel structure Offshore oil rig



PROTECTION OF OIL RIGS

Many metals corrode when exposed to water and air. To prevent underwater or underground metal pipes from corroding, a more reactive metal may be placed in contact with the pipe. Being more reactive, this metal corrodes in preference to the pipe. This technique, called cathodic protection, is commonly used in oil rigs.

REACTIONS OF METALS WITH DILUTE ACIDS

Acid solutions contain hydrogen ions, H^+ , in the form of hydronium ions, H_3O^+ (see pp. 84-85). Reactive metals in an acid solution donate electrons to hydrogen ions, producing hydrogen gas. Metal atoms become positive ions and dissolve. The more reactive the metal, the faster the reaction proceeds. Some metals are so unreactive that they will react only with hot concentrated acid, and some will not react with acids at all.

Magnesium, Mg, is a reactive metal



MAGNESIUM IN DILUTE ACID

Reaction proceeds fairly rapidly

Bubbles of hydrogen gas, H_2

Zinc, Zn, is a fairly reactive metal



ZINC IN DILUTE ACID

Test tube



TIN IN DILUTE ACID

Dilute sulfuric acid, H_2SO_4

Hydrogen gas is given off very slowly



SILVER IN DILUTE ACID

Dilute sulfuric acid, H_2SO_4

Extremely slow reaction

No reaction



PLATINUM IN DILUTE ACID

DISPLACEMENT OF SILVER(I) IONS BY COPPER METAL

Copper wire formed in the shape of a tree



Colorless silver(I) nitrate solution contains silver(I) ions, Ag^+

Glass beaker

Copper is a red-brown metal



COPPER TREE IN SILVER NITRATE SOLUTION

When the copper wire is submerged in a solution of silver(I) nitrate, the copper metal loses electrons to the silver(I) ions.

Copper(II) ions, Cu^{2+} , form and dissolve to make a blue solution

A thick layer of needlelike crystals of silver metal forms on the copper tree



DEPOSITION OF SILVER CRYSTALS

The silver ions are displaced to form silver metal, which coats the copper tree. A blue solution of copper(II) nitrate forms.

COPPER WIRE "TREE"
Here wire made from copper is formed into the shape of a tree. This shape has a large surface area, upon which the reaction can occur.

Electrochemistry

ELECTRICITY PLAYS A PART in all chemical reactions, because all atoms consist of electrically charged particles (see pp. 72-75). A flow of charged particles is called a current, and is usually carried around a circuit by electrons, moved by an electromotive force, or voltage. In solution, the charge carriers are ions, which are also moved by a voltage. A solution containing ions that conducts current is called an electrolyte. There are two basic types of electrochemical systems or cells. In an electrolytic cell, two conductors called electrodes are dipped in an electrolyte, and connected via an external circuit to a battery or other source of voltage. Such a cell can decompose the electrolyte in a process called electrolysis. Electrolytic cells are also used in the electroplating of metals. In a voltaic cell, electrodes of two different metals are dipped in an electrolyte. The electrodes produce a voltage that can drive a current between them. Voltaic cells are the basis of common batteries. In both types of cells, the anode is the electrode at which oxidation occurs, and the cathode the one where reduction occurs. The cathode is the positive terminal of voltaic cells, but negative in electrolytic cells.

ELECTROLYSIS

ELECTROLYTIC DECOMPOSITION OF WATER

Passing an electric current through water decomposes it, producing the gases hydrogen and oxygen. A small amount of an ionic compound is dissolved in the water to make an electrolyte, into which two electrodes are dipped. The battery removes electrons, e^- , from one electrode, the anode, and pushes them toward the cathode. This is an example of an electrolytic cell.

Volume of hydrogen produced is twice that of oxygen

Upright test tube

At the cathode, $4e^-$ are added to $4H_2O$, reducing water to $2H_2 + 4OH^-$

H_3O^+ ions in electrolyte move toward cathode

Bubble of hydrogen gas

Water with dissolved ions

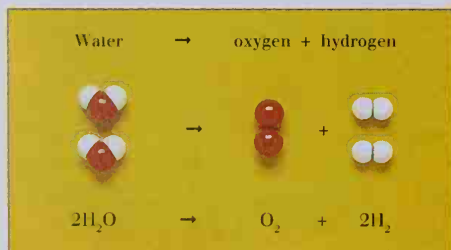

MOLECULAR VIEW OF OVERALL REACTION

Each molecule of water contains one oxygen and two hydrogen atoms. Both gases produced are diatomic - they have two atoms per molecule - so two hydrogen molecules are produced for each oxygen molecule.

ALKALINE DRY CELL (VOLTAIC)

Electrochemistry is put to use in this alkaline dry cell. Powdered zinc metal forms one electrode, while manganese(IV) oxide forms the other. This cell produces electricity at 1.5 volts. Batteries producing 3, 4.5, 6, or 9 volts are made by connecting a series of these cells.

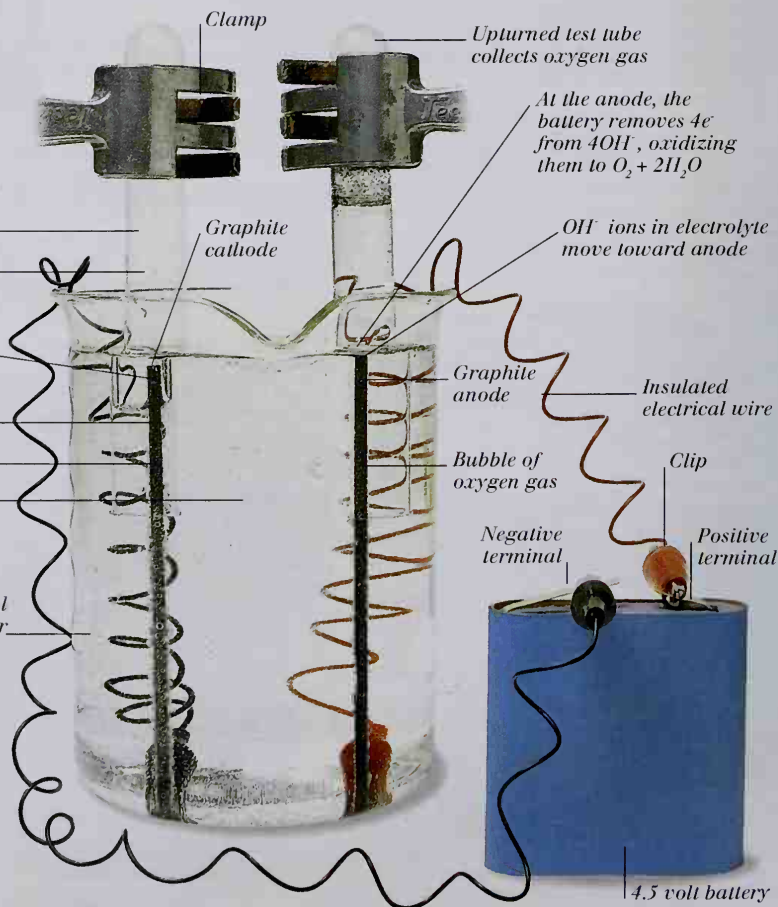
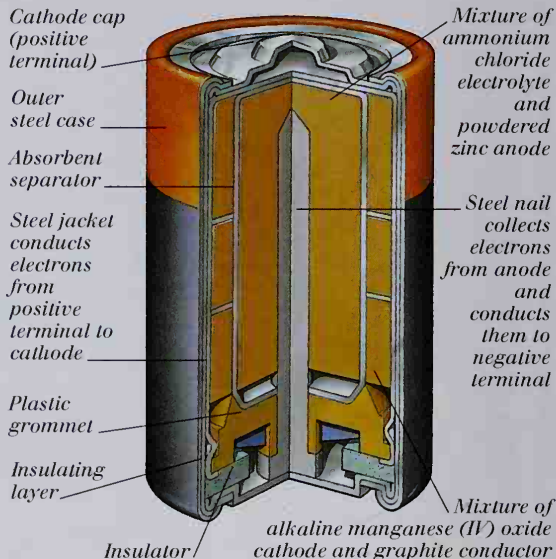

VOLTAIC CELL

PRODUCING A VOLTAGE

When two electrodes of different metals are dipped in an acidic solution so that they do not touch each other, an electric voltage is set up between them. This arrangement is called a voltaic cell. If the two electrodes are connected externally by a wire, the voltage causes an

electric current to flow. In the voltaic cell below, zinc atoms are oxidized to zinc(II) ions at the anode. Electrons from this oxidation flow through the wire, illuminating the lightbulb, to the copper cathode, where hydrogen ions in solution are reduced to hydrogen gas.

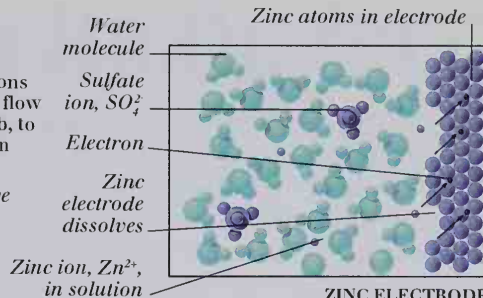

ZINC ELECTRODE

Zinc atoms in the electrode dissolve in the acid, losing electrons to form cations. Oxidation occurs, so this electrode is the anode.

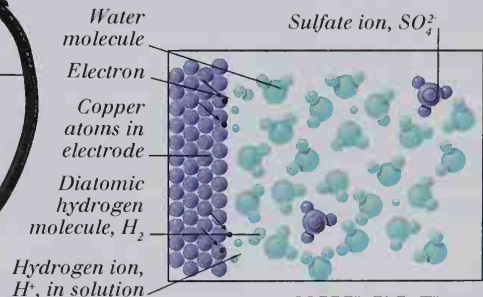

COPPER ELECTRODE

Here, at the cathode, electrons arrive from the zinc anode via the external circuit. They reduce hydrogen ions from the acid, forming hydrogen gas molecules.

Battery removes electrons from copper atoms of anode, forming copper ions

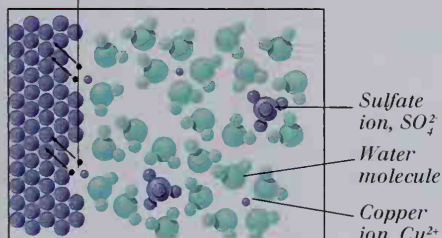

AT THE COPPER PIPE ANODE

The battery's positive terminal draws electrons from the anode, oxidizing the copper atoms to copper(II) cations. These ions dissolve and move toward the cathode.

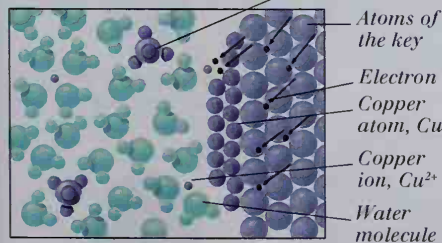

AT THE BRASS KEY CATHODE

Copper ions that have moved to the cathode are reduced to copper atoms by electrons from the battery. These atoms build up on the surface of the brass key cathode.

ELECTROPLATING

COPPER PLATING A KEY

In electroplating, a thin layer of one metal is deposited onto the surface of another. The item to be plated is made the cathode in an electrolytic cell. The electrolyte is a solution containing ions of the other metal. Here, a brass key is plated with copper. The copper ions in solution are replenished from a copper anode.

Battery's positive terminal draws electrons from copper anode

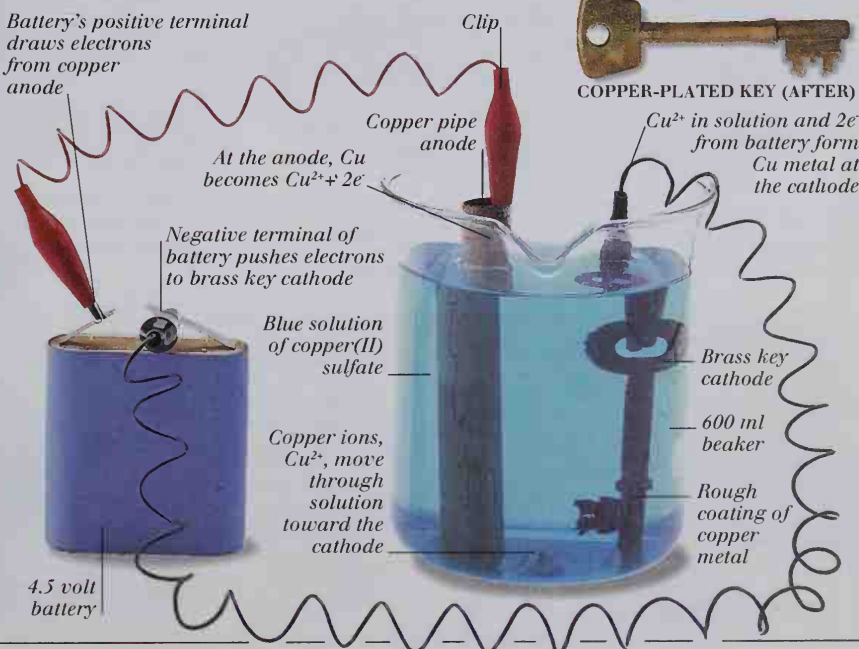

BRASS KEY (BEFORE)



COPPER-PLATED KEY (AFTER)

The alkali metals

THE ELEMENTS OF GROUP 1 of the periodic table (see pp. 74-75) are called the alkali metals. Atoms of these elements have one outer electron. This electron is easily lost, forming singly charged cations such as the lithium ion, Li^+ . As with all cations, the lithium cation is smaller than the lithium atom. All of the elements in this group are highly reactive metals (see pp. 76-77). They react violently with acids, and even react with water, to form alkaline solutions (see pp. 84-85) – hence their group name. The most important element in this group is sodium. Sodium forms many compounds, including sodium chloride, or common salt, and sodium hydrogencarbonate, which is used in baking powder. By far the most important compound of sodium in industrial use is sodium hydroxide. It is manufactured in large quantities, mainly by the electrolysis of brine (a solution of sodium chloride). Sodium hydroxide is a strong base, and it reacts with the fatty acids in fats and oils to produce soap, which is a salt (see pp. 86-87).

POSITION IN THE PERIODIC TABLE

GROUP 1 ELEMENTS

The alkali metals form group 1 of the periodic table. They are (from top): lithium (Li), sodium (Na), potassium (K), rubidium (Rb), cesium (Cs), and francium (Fr).



Potassium is a soft, silvery metal

POTASSIUM METAL

REACTION WITH WATER

Red litmus solution

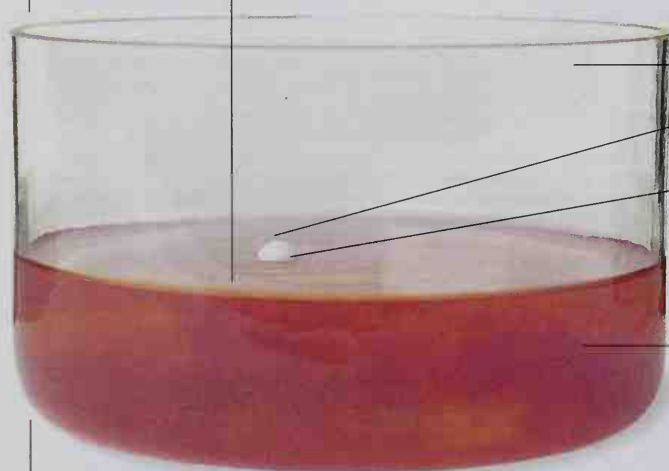

Glass bowl

The reaction evolves heat

Sodium skims across the surface on a cushion of steam and hydrogen gas

Red litmus begins to turn blue as alkaline sodium hydroxide solution forms

SODIUM IN INDICATOR SOLUTION

A piece of pure sodium metal reacts dangerously with water. Here, red litmus indicator is dissolved in the water. Explosive hydrogen gas is given off by the reaction, and the litmus turns blue with the resulting sodium hydroxide solution (above).

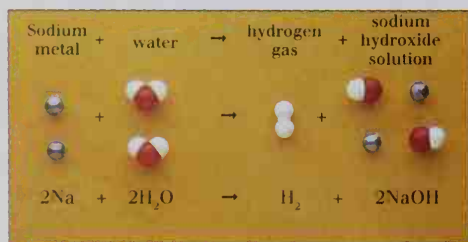

MOLECULAR VIEW

Sodium atoms lose electrons to form sodium cations, Na^+ , which dissolve in water. Water molecules each gain an electron and split into a hydroxide anion, which dissolves, and a hydrogen atom. Two atoms of hydrogen combine to form hydrogen gas, H_2 .

ATOMS AND CATIONS

Atoms of the alkali metals have one electron, which is easily lost, in their outer electron shell. The cation formed is much smaller than the atom. Atomic and ionic diameters are given below for the first four alkali metals, measured in picometers (1 picometer, pm, is 10^{-12} m). Electron configurations of the elements are also given.



Atomic diameter
304 pm

LITHIUM ATOM, $1\text{S}^2 2\text{S}^1$



Ionic diameter
136 pm

LITHIUM ION, 1S^2



Atomic diameter
370 pm

SODIUM ATOM, $1\text{S}^2 2\text{S}^2 2\text{P}^6 3\text{S}^1$



Ionic diameter
194 pm

SODIUM ION, $1\text{S}^2 2\text{S}^2 2\text{P}^6$



Ionic diameter
266 pm

POTASSIUM ATOM, $1\text{S}^2 2\text{S}^2 2\text{P}^6 3\text{S}^2 3\text{P}^6 4\text{S}^1$

Atomic diameter
462 pm



POTASSIUM ION, $1\text{S}^2 2\text{S}^2 2\text{P}^6 3\text{S}^2 3\text{P}^6$



Ionic diameter
294 pm

RUBIDIUM ATOM, $1\text{S}^2 2\text{S}^2 2\text{P}^6 3\text{S}^2 3\text{P}^6 3\text{D}^{10} 4\text{S}^2 4\text{P}^6 5\text{S}^1$

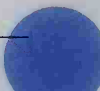

Atomic diameter
492 pm

RUBIDIUM ION, $1\text{S}^2 2\text{S}^2 2\text{P}^6 3\text{S}^2 3\text{P}^6 3\text{D}^{10} 4\text{S}^2 4\text{P}^6$

SODIUM HYDROGENCARBONATE

Sodium hydrogen carbonate, NaHCO_3 , also known as sodium bicarbonate – is a weak base that decomposes on heating or on reaction with an acid, releasing carbon dioxide gas (see pp. 84-85). This white powder is used as a raising agent in cooking, and is an important ingredient of soda bread.

Sodium hydrogen carbonate decomposes in the heat of the oven, producing carbon dioxide gas



SODA BREAD

MANUFACTURE OF SODIUM HYDROXIDE

Much of the sodium hydroxide, NaOH , manufactured is made by the mercury cathode process. This two-stage process begins with the electrolysis of brine, NaCl , to give chlorine gas and pure sodium. The sodium then reacts with water to give sodium hydroxide solution. Mercury is very toxic, and this process is banned in some countries.

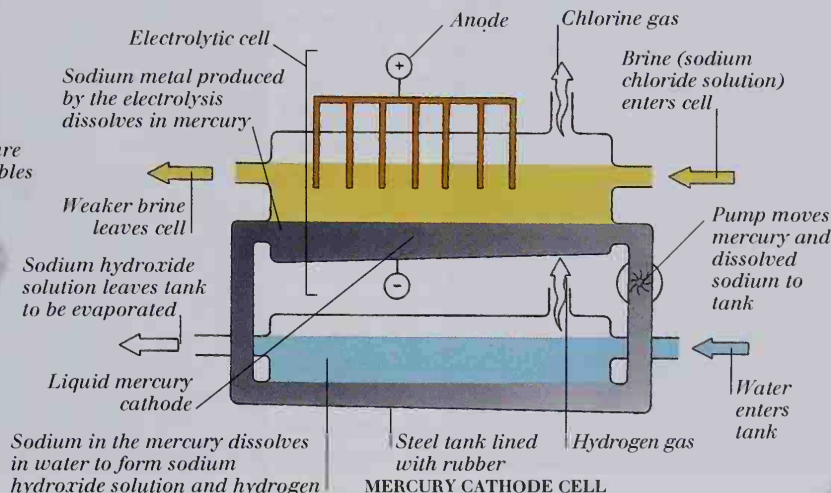

PRODUCTION OF SOAP

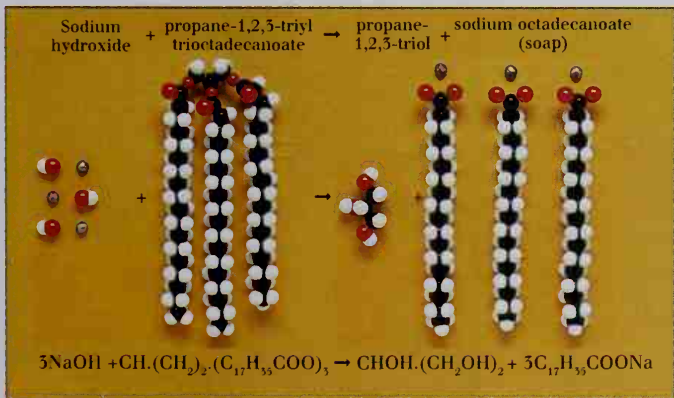

MOLECULAR VIEW

The oil molecule shown consists of three long-chain fatty acids linked by propane-1,2,3-triol (glycerol). Sodium hydroxide reacts with the fatty acids from the oil to produce glycerol and the salt sodium octadecanoate.

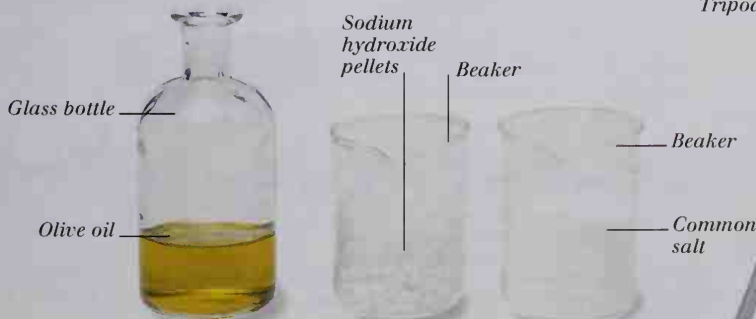

LABORATORY PREPARATION
When fatty acids – weak acids found in fats and oils – are heated with sodium hydroxide, a strong base, they react to produce a mixture of salts. The main product is the salt sodium octadecanoate, $\text{C}_{17}\text{H}_{33}\text{COONa}$ (a soap). Common salt (sodium chloride) helps to separate the soap from the mixture.

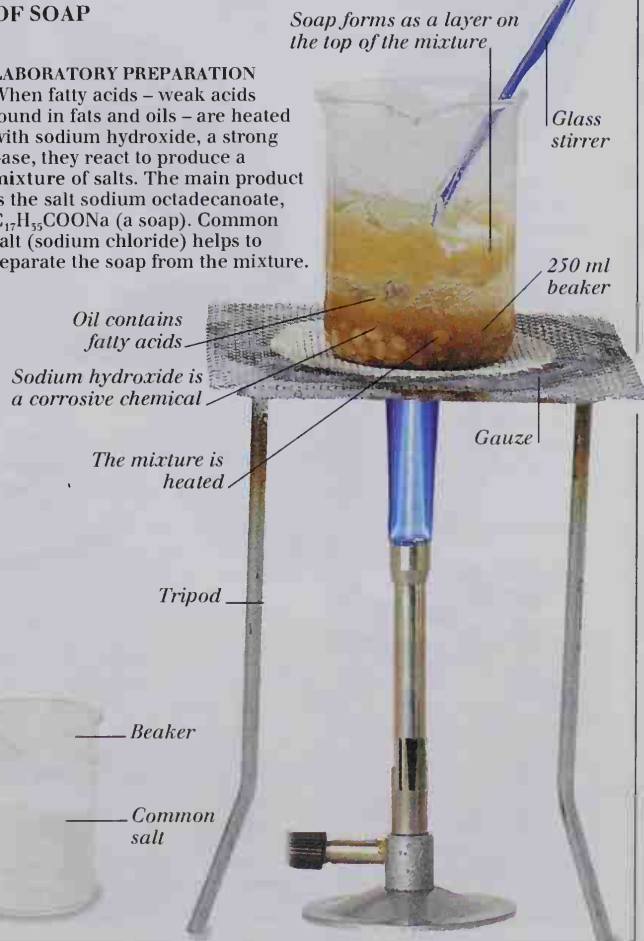

The alkaline earth metals

THE ELEMENTS OF THE SECOND GROUP of the periodic table (see pp. 74-75) are called the alkaline earth metals. These elements are **reactive**, because their **atoms** easily lose two outer **electrons** to form doubly charged **cations**, such as the calcium ion, Ca^{2+} . Hard water, which contains large numbers of dissolved ions, often contains calcium ions. It is formed when slightly **acidic** water flows over rocks containing calcium salts such as calcium carbonate. The dissolved calcium salts can come out of **solution** from hard water, forming the scale that blocks kettles and hot water pipes. It is difficult to create a lather with soap when using hard water. In fact, a simple way to measure the hardness of water is to **titrate** it with a soap solution. Calcium **compounds** are an important constituent of mortar, which is used as a cement in bricklaying. Magnesium, another group 2 element, is found in the pigment chlorophyll, which gives green plants their color. Alkaline earth metals are commonly used in the manufacture of fireworks, and barium is used in hospitals for the production of X rays of the digestive system.

MAGNESIUM IN CHLOROPHYLL

Leaf

CHLOROPHYLL IN GREEN PLANTS
Green plants contain large amounts of a vital compound called chlorophyll. It absorbs energy from sunlight in a process called **photosynthesis**. The energy is used to make sugars (see pp. 114-115) from carbon dioxide and water.

Green color is caused by magnesium in chlorophyll pigment

Leaf contains a store of energy built up by photosynthesis

Each cell of the leaf contains chlorophyll

Molecule head

Nitrogen atom

Magnesium atom

MOLECULE OF CHLOROPHYLL
The group 2 element magnesium plays a vital role in the chlorophyll molecule. Located at the center of the porphyrin ring in the head of the molecule, it absorbs light energy as part of the process of photosynthesis.

Porphyrin ring

Phytol side-chain

Carbon atom

Tail of molecule

Covalent bonds

Hydrogen atom

POSITION IN THE PERIODIC TABLE

GROUP 2 ELEMENTS

The metals of group 2 of the periodic table are (from top): beryllium (Be), magnesium (Mg), calcium (Ca), strontium (Sr), barium (Ba), and radium (Ra).

HARDNESS OF WATER

COMPARATIVE TITRATION

Hard water contains calcium hydrogencarbonate, $\text{Ca}(\text{HCO}_3)_2$, or other dissolved salts. These salts increase the amount of soap needed to produce a lather. The hardness of different water samples may be compared by titrating them with a soap solution of fixed concentration.

Soap solution contains a little alcohol to prevent clouding

Burette reading is noted

TESTING HARD WATER

A solution of liquid soap in water is slowly added to a sample of hard water. The water is shaken occasionally, and the volume of soap solution is noted when a lather begins to form. Different water samples require different amounts of soap.

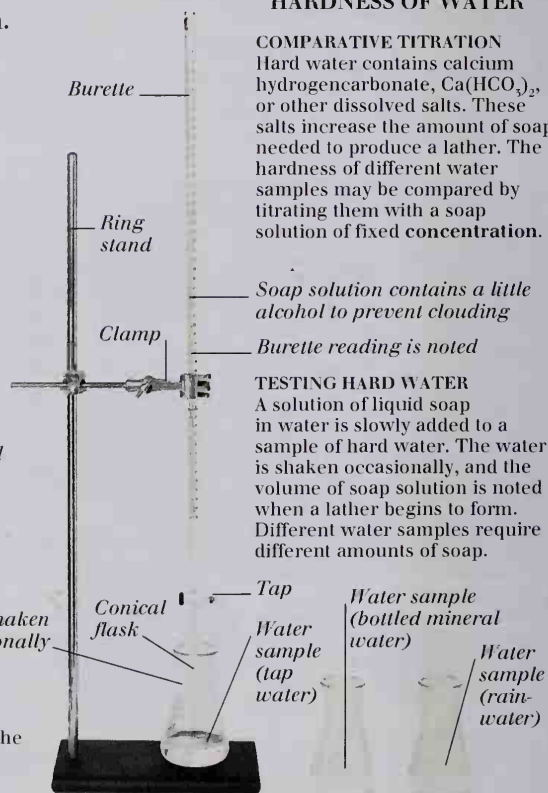

ALKALINE EARTH METALS IN FIREWORKS

Red color given by
strontium salts



CHARACTERISTIC COLOURS

Group 2 elements produce bright colors when heated in a flame (see pp. 116-117). For this reason, compounds of the elements are used in fireworks. As gunpowder in the fireworks burns, electrons in the group 2 atoms absorb heat energy and radiate it out as light of characteristic colors.

BARIUM MEAL

Large
intestine

Skeleton



Magnesium
salts give an
intense white
color

Appendix
Pink areas
correspond
to blocking
of X rays by
barium

X-RAY PHOTOGRAPH OF DIGESTIVE SYSTEM

To obtain an X ray of the digestive system, a "meal" of barium sulphate, BaSO_4 , is administered to the patient. X rays pass through human tissue, but are stopped by atoms of barium.

CALCIUM COMPOUNDS IN MORTAR

PRODUCTION OF MORTAR

Bricklayers' mortar is calcium hydroxide – also known as slaked lime, Ca(OH)_2 – dissolved in water, and mixed with sand for bulk. As the mixture dries, the slaked lime crystallizes out of solution, and slowly reacts with carbon dioxide in the air to form hard calcium carbonate (see below).

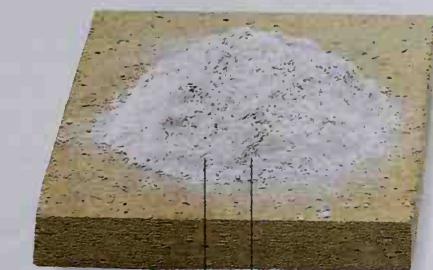

Sand and calcium
hydroxide, Ca(OH)_2 ,
mixed with water

The ingredients
are mixed
thoroughly



250ml
beaker

Water

Spatula

Mold containing
wet mortar



Mortar takes the
shape of the mold

Water evaporates
from the mixture

Mortar hardens as it
reacts with carbon
dioxide in air to form
calcium carbonate

MOLECULAR VIEW
Calcium ions, Ca^{2+} , and hydroxide ions, OH^- , form when slaked lime dissolves in water. Carbon dioxide, CO_2 , combines with the ions as water leaves the mixture. This reaction is also the basis of a test for carbon dioxide (see pp. 116-117).

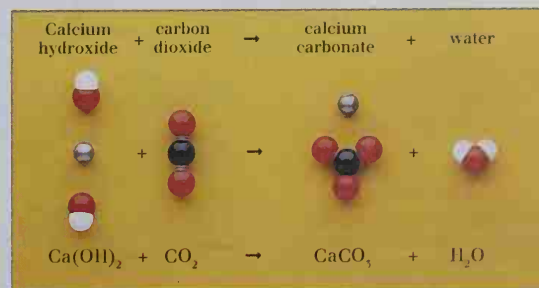

Transition metals

THE TRANSITION METALS MAKE UP MOST of the periodic table (see pp. 74-75). Some of the elements are very familiar – for example, gold and silver are used in jewelry, copper is used in electrical wiring and water pipes, and tungsten forms the filaments of incandescent light bulbs. Transition metals share many properties – for example, they all have more than one oxidation number. In compounds, chromium commonly has oxidation numbers of +2, +3, or +6. Like most transition metals, it forms colored ions in solution, such as the chromate(VI) and the dichromate(VI) ions. Copper also exhibits typical transition metal behavior – it forms brightly colored compounds and complex ions. Perhaps the most important of the transition metals is iron. It is the most widely used of all metals, and is usually alloyed with precise amounts of carbon and other elements to form steel. Around 760 million tons of steel are produced per year worldwide, most of it by the basic oxygen process. Chromium is used in stainless steel alloys, and as a shiny protective plating on other metals.

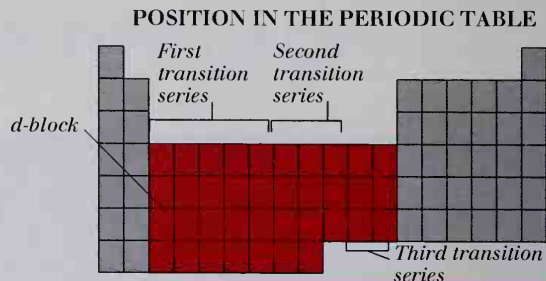

D- AND F-BLOCK ELEMENTS

Most of the transition metals lie in the d-block of the periodic table. The lanthanides and actinides, in the f-block, are also transition metals.

THREE D-BLOCK TRANSITION METALS

Gold is very unreactive



GOLD

Silver compounds are used in photographic film



SILVER

Platinum is often used as a catalyst



PLATINUM

COPPER – A TRANSITION METAL

THREE TRANSITION METAL COMPOUNDS



CHROMIUM(III) OXIDE

Like many chromium compounds, chromium(III) oxide, Cr_2O_3 , is used as a pigment

COMPOUNDS OF COPPER
Like most of the transition metals, copper forms brightly colored compounds. All of the compounds shown here are of copper(II), and they all contain the ion Cu^{2+} .



CHROMIUM(VI) OXIDE

Chromium(VI) oxide, CrO_3 , is highly poisonous



LEAD(II) OXIDE

This form of lead(II) oxide is called litharge

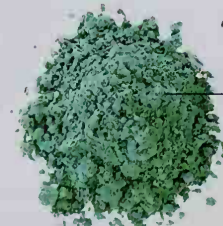

COPPER(II) CARBONATE

Copper(II) carbonate contains the carbonate radical, CO_3^{2-}

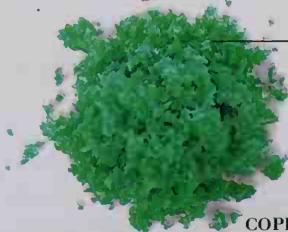

COPPER(II) CHLORIDE

This blue-green sample of copper(II) chloride contains water of crystallization



COPPER(I) OXIDE

Red-brown copper turnings

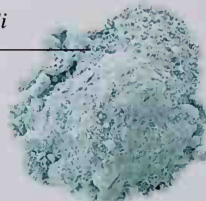

COPPER(II) HYDROXIDE

Copper(II) oxide, CuO , is used as a catalyst in a number of reactions

COPPER(II) NITRATE
Copper(II) nitrate is hygroscopic, which means that it absorbs water from the air

COPPER METAL

Copper was one of the first metals to be used by humans

MANUFACTURE OF STEEL



THE BASIC OXYGEN PROCESS

More than half the world's steel is produced by the basic oxygen process. This photograph shows a basic oxygen furnace (right) being charged, or filled, with molten iron.

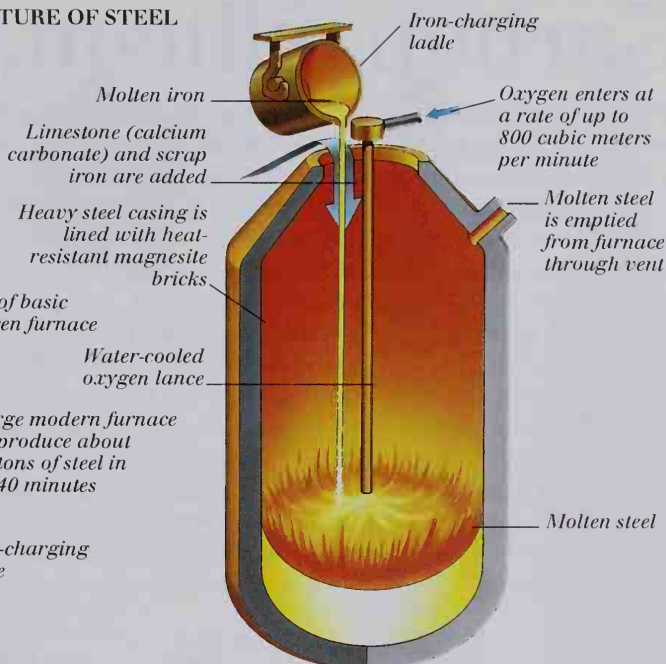

BASIC OXYGEN FURNACE

Iron from a blast furnace is tipped into the basic oxygen furnace. Oxygen is pumped in to purify the iron by combining with carbon impurities. When the "blow" of oxygen is complete, the furnace is tilted to empty the steel.

CHROMATE IONS IN A REVERSIBLE REACTION



POTASSIUM CHROMATE SOLUTION

When dissolved in water, the compound potassium chromate(VI), K_2CrO_4 , has a bright yellow color. Chromium in the compound has an oxidation number of +6.

POTASSIUM DICHROMATE SOLUTION

Adding an acid to the solution moves the position of the equilibrium. Two chromate(VI) ions combine to produce the dichromate(VI) ion, $\text{Cr}_2\text{O}_7^{2-}$, and water.

THE REVERSE REACTION

The addition of more water or an alkaline solution will push the reversible reaction in the direction of the original reactants. A yellow solution of chromate(VI) ions forms once more.

Carbon, silicon, and tin

GROUP 14 OF THE periodic table (see pp. 74-75) contains the elements carbon, silicon, and tin. Carbon is a nonmetal that is the basis of organic chemistry (see pp. 112-115). It occurs in three distinct forms, or **allotropes**. In the most recently discovered of these, called the fullerenes, carbon atoms join together in a hollow spherical cage. The other, more familiar, allotropes of carbon are graphite and diamond. All of the elements in group 14 form **sp hybrid orbitals** (see p. 79). In particular, sp^3 hybrid orbitals give a tetrahedral structure to many of the **compounds** of these elements. Silicon is a semimetal that is used in electronic components. It is found naturally in many types of rocks, including quartz, which consists of silicon (IV) oxide. Quartz is the main constituent of sand, which is used to make glass. Tin is a metallic element. It is not very useful in its pure form, because it is soft and weak. However, combined with other metals, it forms useful **alloys**, such as solder and bronze.

POSITION IN THE PERIODIC TABLE

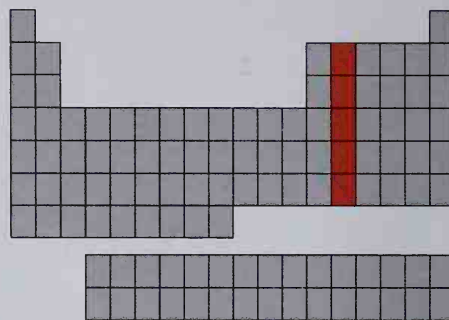

GROUP 14 ELEMENTS

Group 14 of the periodic table consists of (top to bottom): carbon (C), silicon (Si), germanium (Ge), tin (Sn), and lead (Pb).

THE ELEMENTS

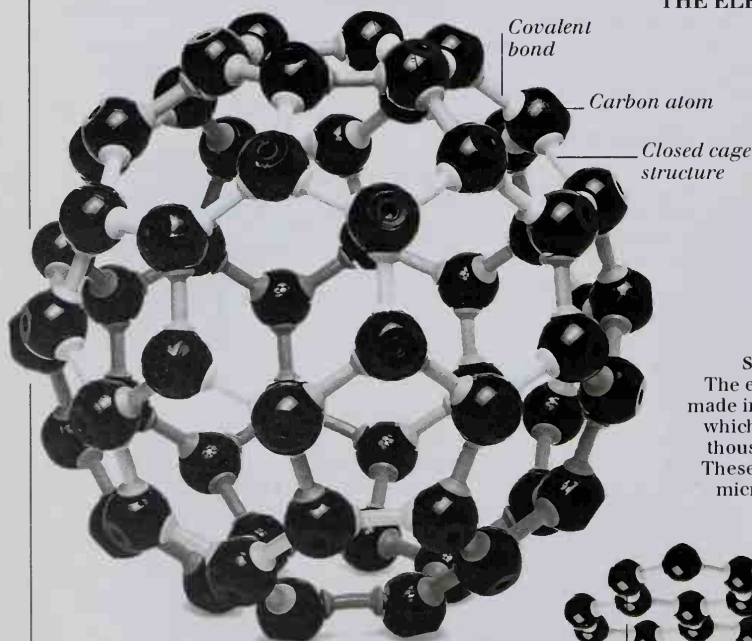

BUCKMINSTERFULLERENE, C_{60}
Carbon atoms form network structures called fullerenes. The best-known of these is buckminsterfullerene, which consists of 60 carbon atoms arranged as interlinked hexagons and pentagons. It occurs in nature in minute amounts, but can be made in the laboratory.

STRUCTURE OF GRAPHITE
Graphite is an allotrope of carbon which, combined with various clays, forms the "lead" of pencils. The carbon atoms in graphite form layers that are loosely bound together, and slip easily over each other.

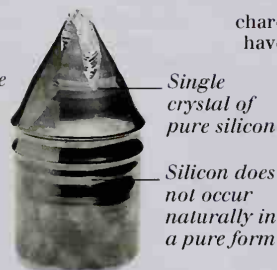
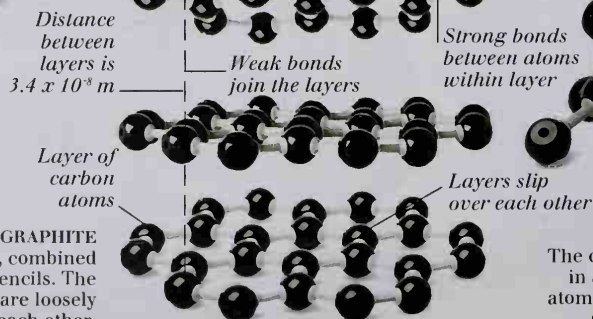

SILICON CRYSTAL

The element silicon can be made into large, pure crystals, which can be used to make thousands of silicon chips. These chips are the basis of microelectronic circuits.

ALLOTTROPES OF CARBON
The main allotropes of carbon are graphite and diamond (below). In charcoal, carbon does not have a regular structure.



DIAMOND

Bond formed with sp^3 hybrid orbital

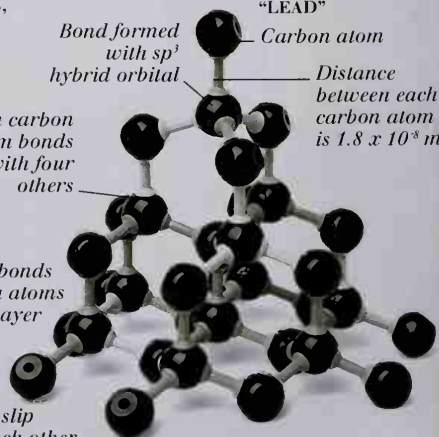

STRUCTURE OF DIAMOND

The carbon atoms in a diamond are bonded in a very strong structure. Each carbon atom is bound directly to four others, which sit at the corners of a tetrahedron.



GRAPHITE IN PENCIL "LEAD" CHARCOAL

SP³ HYBRIDIZATION

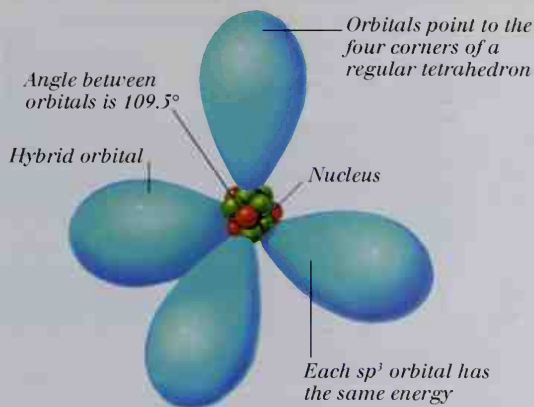

FORMATION OF SP³ ORBITALS

The elements in group 14 of the periodic table have one s- and three p-orbitals in their outer electron shells. These combine to form four sp³ hybrid orbitals in many of the compounds of the elements.

Sodium carbonate lowers the melting point of sand, but makes the glass soluble in water



SODIUM CARBONATE

Calcium carbonate lowers the melting point of sand without making the glass soluble in water



CALCIUM CARBONATE



SAND (MAINLY QUARTZ)

Barium carbonate gives glass a brown color



BARIUM CARBONATE

Iron(III) oxide gives glass a green color



IRON(III) OXIDE

QUARTZ AND GLASS

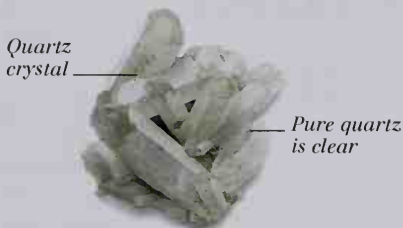

QUARTZ
Quartz is the most abundant rock type on Earth. It consists mainly of the compound silicon(IV) oxide.

GLASS
Glass is made from molten sand, which consists mainly of quartz (above). Sodium and calcium salts are added to lower the melting point of the sand. The glass can be colored by adding impurities such as barium carbonate and iron(III) oxide.



BROWN GLASS BOTTLE

GREEN GLASS BOTTLE

ALLOYS OF TIN



SOLDER

The most convenient way to connect wires and components permanently in electric circuits is to use solder. Solder is a soft alloy of tin and lead that has a low melting point (200-300°C).

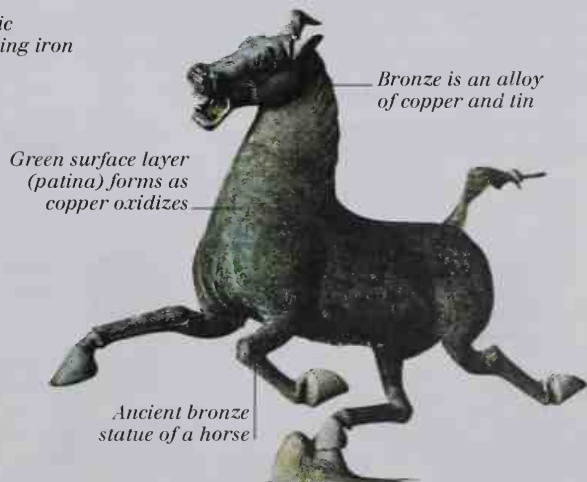

Bronze is an alloy of copper and tin
Green surface layer (patina) forms as copper oxidizes
Ancient bronze statue of a horse

BRONZE

First made about 5,000 years ago, bronze is an alloy of tin and copper (see pp. 102-103). It is easily cast when molten, but very hard-wearing when solidified.

Nitrogen and phosphorus

NITROGEN AND PHOSPHORUS are the two most important elements in group 15 of the periodic table (see pp. 74-75). Phosphorus, which is solid at room temperature, occurs in two forms, or **allotropes**, called white and red phosphorus. Nitrogen is a gas at room temperature, and makes up about 78% of air (see pp. 70-71). Fairly pure nitrogen can be prepared in the laboratory by removing oxygen, water vapor, and carbon dioxide from air. By far the most important compound of nitrogen is ammonia (see pp. 92-93), of which over 88 million tons are produced each year worldwide. Used in the manufacture of fertilizers, explosives, and nitric acid, ammonia is produced industrially by the Haber process, for which nitrogen and hydrogen are the raw materials. Ammonia forms a positive ion called the ammonium ion (NH_4^+) that occurs in salts, where it acts like a metal cation (see pp. 76-77). Ammonia can be prepared in the laboratory by heating an ammonium salt with an alkali, such as calcium hydroxide.

PREPARATION OF NITROGEN FROM AIR
Nitrogen is the most abundant gas in the air. Other gases that make up more than 1% of the air are oxygen (about 20%) and water vapor (0-4%). Air is passed through sodium hydroxide solution, which dissolves the small amounts of carbon dioxide present. It is then passed through concentrated sulfuric acid to remove water vapor, and, finally, over heated copper metal to remove oxygen. The result is almost pure nitrogen.

Air is pumped slowly through the apparatus from this glass tube

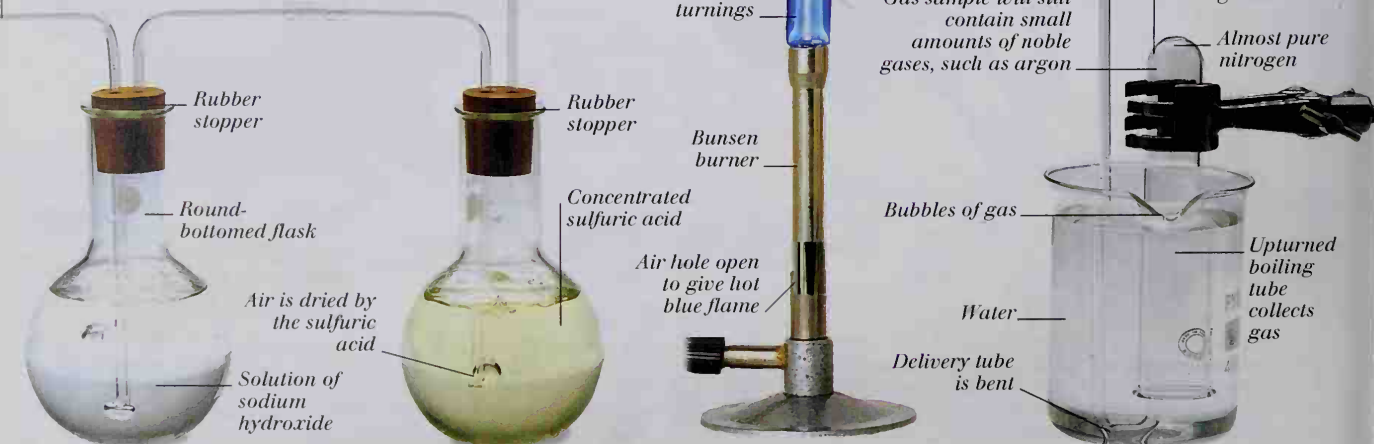

THE POSITION OF NITROGEN AND PHOSPHORUS IN THE PERIODIC TABLE

Nitrogen (N, uppermost) and phosphorus (P) are nonmetals that belong to group 15 of the periodic table.

ALLOTROPES OF PHOSPHORUS

There are two common allotropes of phosphorus. White phosphorus reacts violently with air, so it is kept in water, in which it does not dissolve. It changes slowly to the noncrystalline red form, which is chemically less reactive.

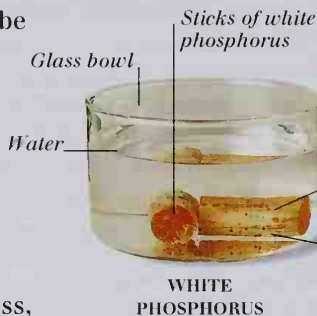

White phosphorus is a white, waxy solid

White phosphorus melts at 44.1°C

Red phosphorus melts at about 600°C



Red phosphorus is a red powder at room temperature

THE HABER PROCESS

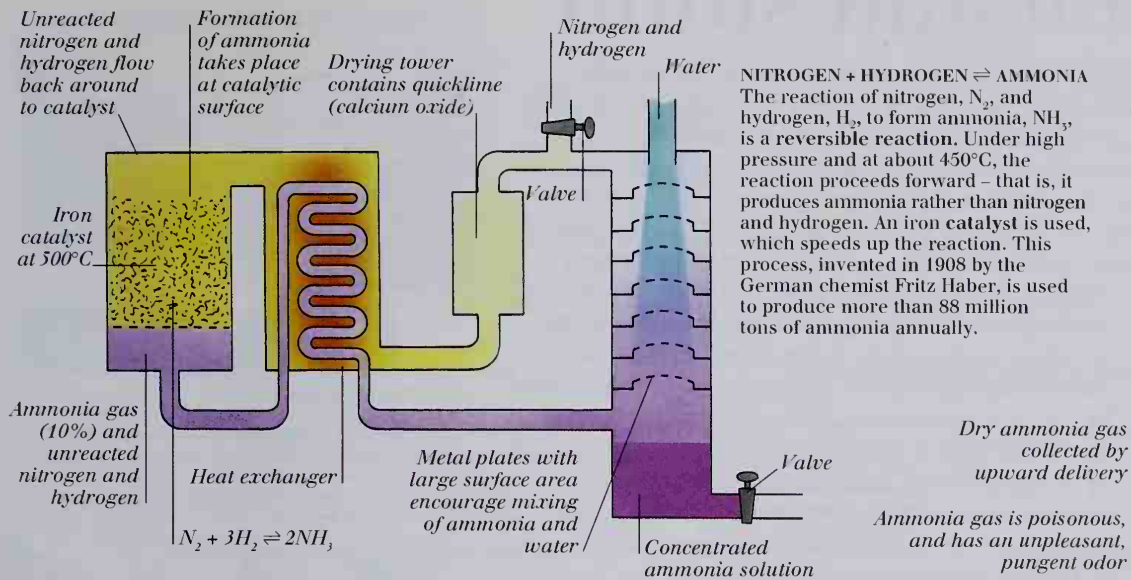

LABORATORY PREPARATION OF AMMONIA

In the laboratory, ammonia can be prepared by heating an ammonium salt with an alkali. Here, ammonium chloride, NH_4Cl , and calcium hydroxide, $Ca(OH)_2$, are heated in a flask. The ammonia produced is dried and collected in a gas jar.

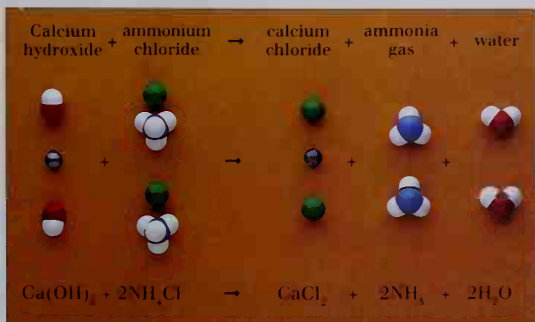
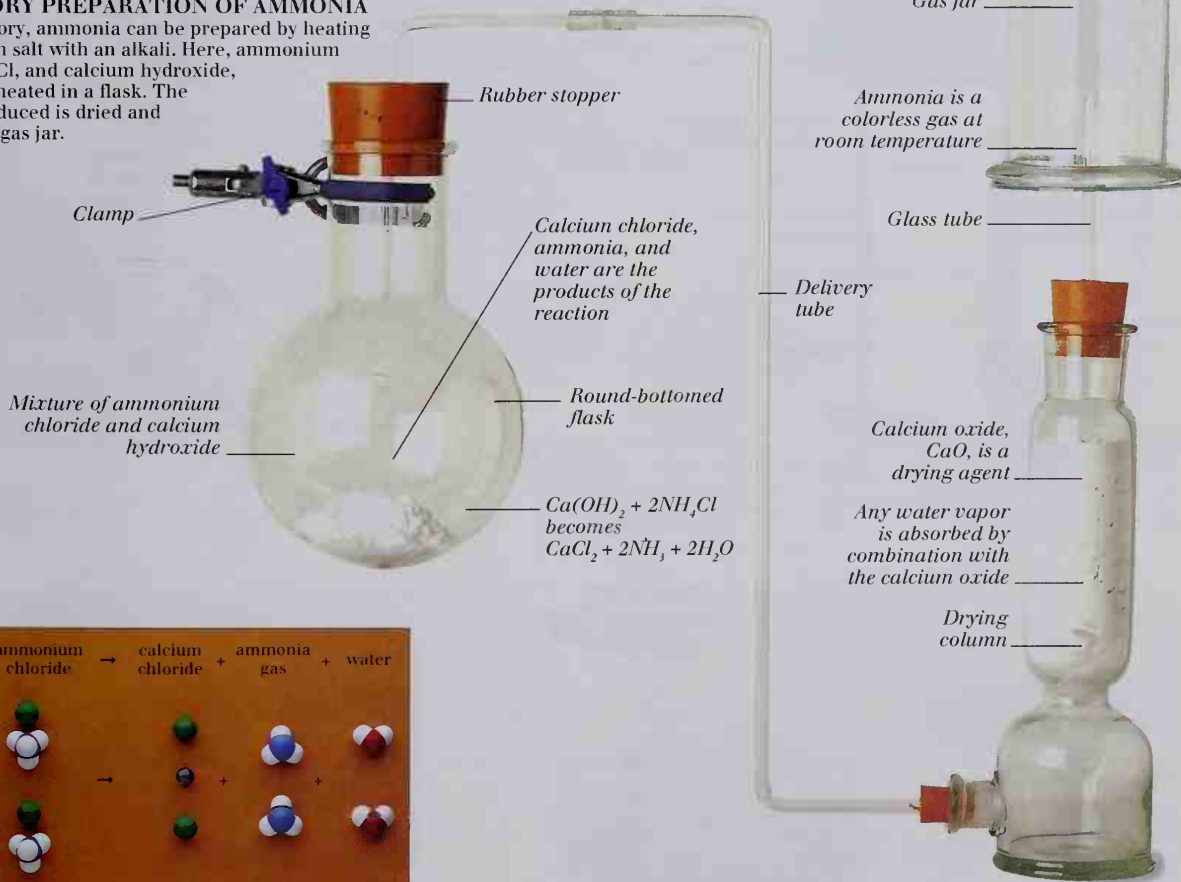

MOLECULAR VIEW OF REACTION

Oxygen and sulfur

THE TWO MOST IMPORTANT elements in group 16 of the periodic table are oxygen and sulfur. Oxygen, a gas at STP, is vital to life, and is one of the most abundant elements on Earth. It makes up 21% by volume of dry air (see pp. 70-71). In the laboratory, oxygen is easily prepared by the decomposition of hydrogen peroxide. Oxygen is involved in **burning** – it relights a glowing wooden splint, and this is one test for the gas. Sulfur occurs in several different structural

forms, known as **allotropes**. The most stable allotrope at room temperature is rhombic sulfur, in which sulfur exists in the form of rings, each containing eight atoms. One important **compound** of sulfur is hydrogen sulfide. It has a pungent smell like that of rotten eggs, and can be prepared by reacting dilute acids with metal sulfides. Sodium thiosulfate is another important sulfur compound, used as a fixative in the development of photographic images.

POSITION IN THE PERIODIC TABLE

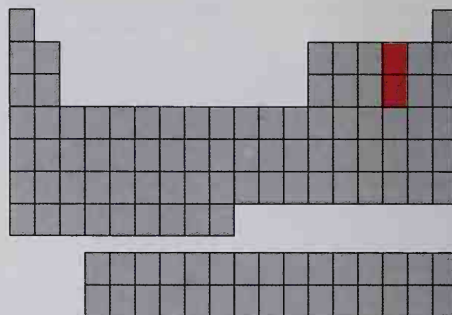

GROUP 16 ELEMENTS

Oxygen (top) and sulfur are in group 16 of the periodic table. They are both nonmetallic elements, which form a wide range of compounds.

TEST FOR OXYGEN

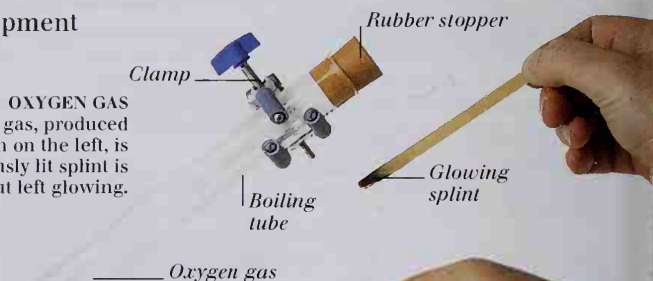

OXYGEN GAS

A tube full of oxygen gas, produced in the reaction on the left, is sealed. A previously lit splint is extinguished, but left glowing.

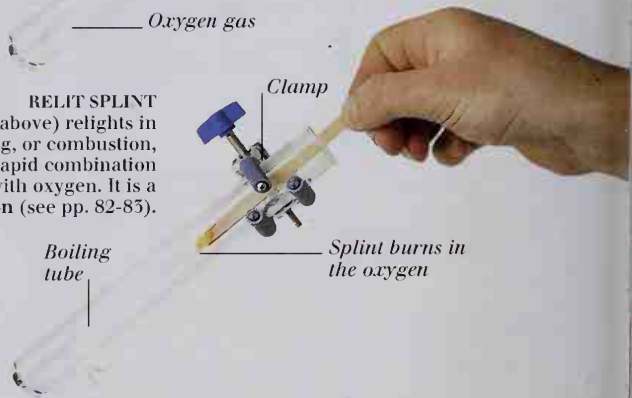

RELIT SPLINT

The glowing splint (above) relights in the oxygen. Burning, or combustion, is defined as a rapid combination of a substance with oxygen. It is a redox reaction (see pp. 82-85).

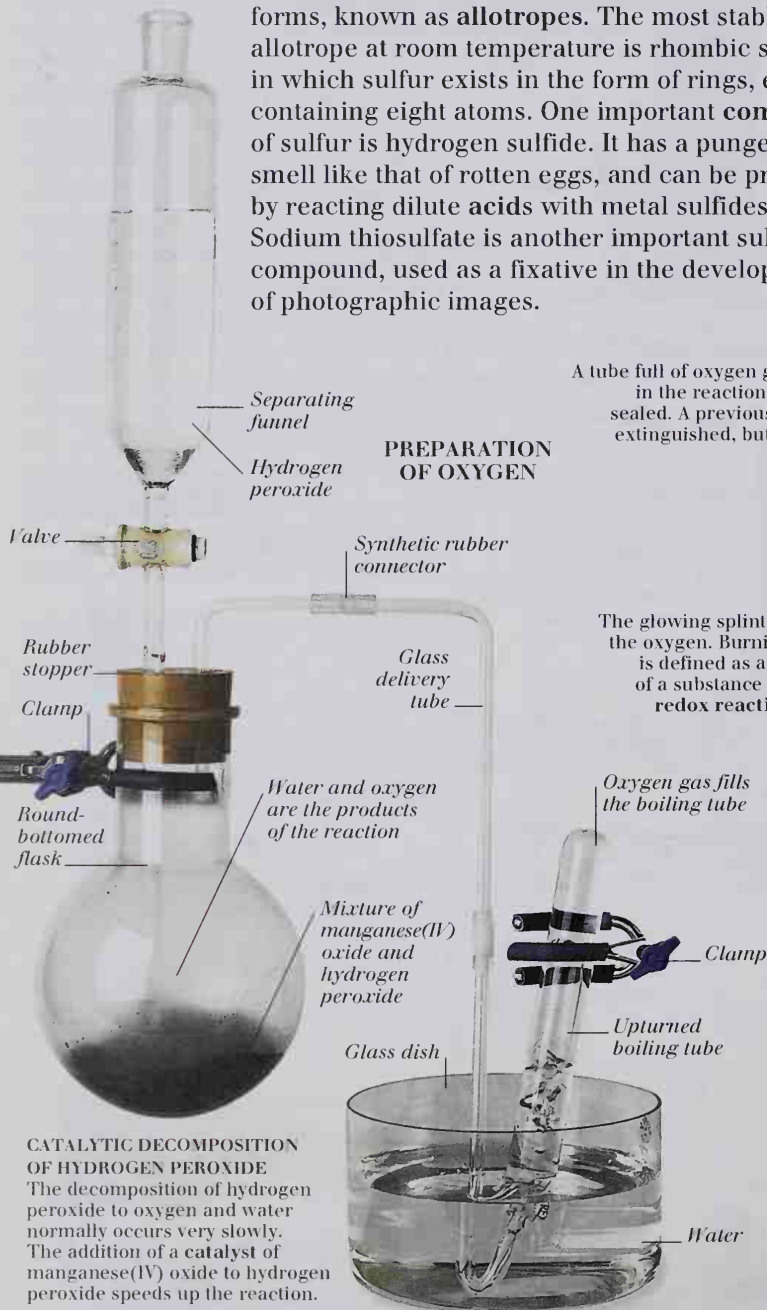

PREPARATION OF OXYGEN

CATALYTIC DECOMPOSITION OF HYDROGEN PEROXIDE

The decomposition of hydrogen peroxide to oxygen and water normally occurs very slowly. The addition of a catalyst of manganese(IV) oxide to hydrogen peroxide speeds up the reaction.

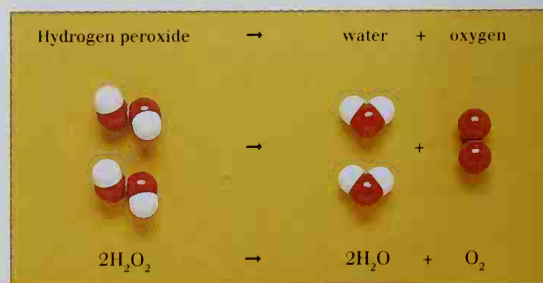

MOLECULAR VIEW

Hydrogen peroxide exists as **molecules**, each consisting of two hydrogen and two oxygen **atoms**. Every two molecules of hydrogen peroxide produce one molecule of oxygen. Water is the other product.

ALLOTROPES OF SULFUR



POWDERED SULFUR
In the laboratory, sulfur is usually supplied as a powder. Each grain of the powder is a crystal of rhombic sulfur (right).

Crystal of rhombic sulfur



RHOMBIC (α) SULFUR
The most stable allotrope of sulfur at room temperature is rhombic sulfur, also known as alpha (α) sulfur.

Plastic sulfur forms crystals on cooling



PLASTIC SULFUR
If molten sulfur is cooled by plunging it into cold water, yellow or brown plastic sulfur, which is noncrystalline, forms.

Watch glass

Crystals formed by rapidly cooling molten sulfur



MONOCLINIC (β) SULFUR
Needle-like crystals of monoclinic (β, or beta) sulfur slowly revert to the rhombic form at temperatures below 95.5°C (203.9°F).

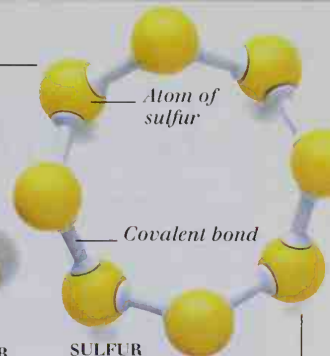

SULFUR RINGS
Monoclinic and rhombic sulfur both contain crown-shaped molecules of eight sulfur atoms.

LABORATORY PREPARATION OF HYDROGEN SULFIDE



The pungent gas hydrogen sulfide, H_2S , is normally prepared by the action of a dilute acid on metal sulfides. In this case, the reactants are hydrochloric acid, HCl , and iron(II) sulfide, FeS .

PREPARATION OF SODIUM THIOSULFATE

The compound sodium thiosulfate, $Na_2S_2O_3$, is normally combined with water of crystallization. It is used as photographers' fixative, "hypo." Sodium thiosulfate is prepared by heating a suspension of sulfur in a sodium sulfite, Na_2SO_3 , solution.

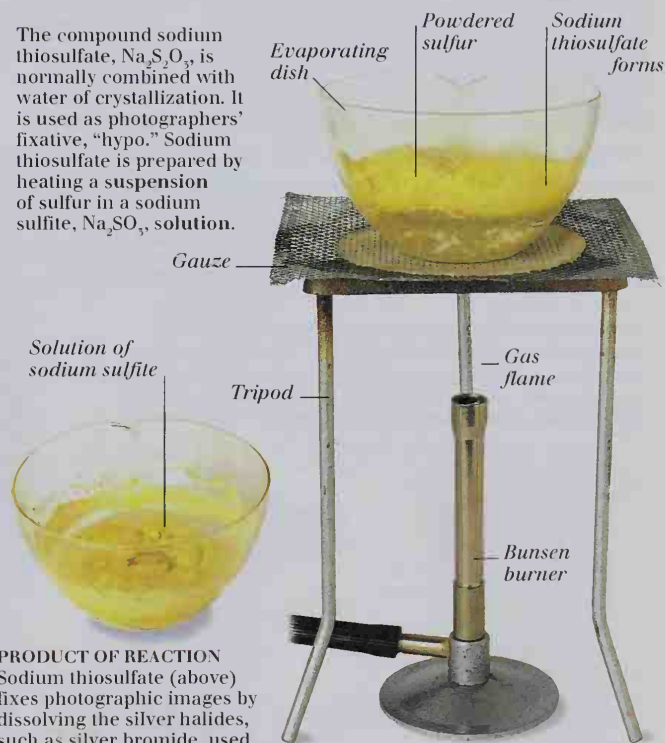

PRODUCT OF REACTION
Sodium thiosulfate (above) fixes photographic images by dissolving the silver halides, such as silver bromide, used in photographic film (see p. 88).

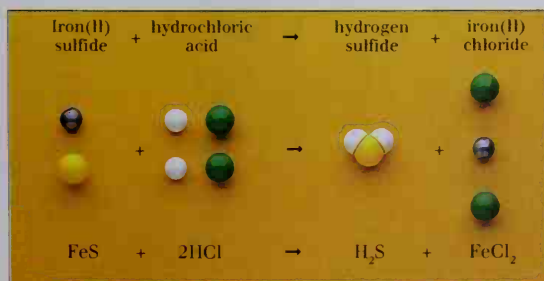

MOLECULAR VIEW

Hydrogen ions in hydrochloric acid combine with the sulfur from iron(II) sulfide. Hydrogen sulfide molecules have a similar shape to water molecules (see p. 68).

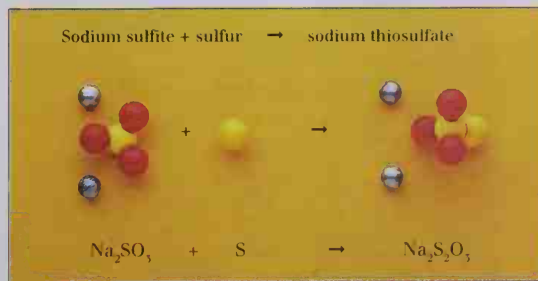

MOLECULAR VIEW

Sulfur in the sulfite ion has an oxidation number of +4. In the thiosulfate ion produced by the reaction above, sulfur(IV) has been oxidized to sulfur(VI), while elemental sulfur has been reduced to an oxidation state of -2.

The halogens

THE ELEMENTS OF GROUP 17 of the periodic table (see pp. 74-75) are called the halogens. Atoms of these elements are just one electron short of a full outer electron shell. Halogen atoms easily gain single electrons, forming singly charged halide anions such as the fluoride ion, F^- . This makes the elements in this group highly reactive – some halogens will even react with the noble gases under extreme conditions. Chlorine, the most important halogen, is a greenish yellow diatomic gas at room temperature. Chlorine can be prepared in the laboratory by the oxidation of hydrochloric acid. Small amounts of chlorine are added to water in swimming pools, and to some water supplies, to kill bacteria. Simple tests may be used to measure the amount of dissolved chlorine. If the concentration of chlorine is too high, it can endanger human health – if it is too low, it might not be effective. One important chlorine compound is sodium chlorate(I), the main ingredient of domestic bleach. Other halogen compounds include CFCs (chlorofluorocarbons). CFCs deplete, or break down, the ozone layer in the upper atmosphere, allowing harmful radiation from the Sun to reach the Earth's surface.

BROMINE AND IODINE

The element bromine is a red liquid at room temperature, though it vaporizes easily, producing a brown vapor. Iodine is a violet solid at room temperature, which sublimes (turns to vapor without passing through a liquid phase) when warmed.

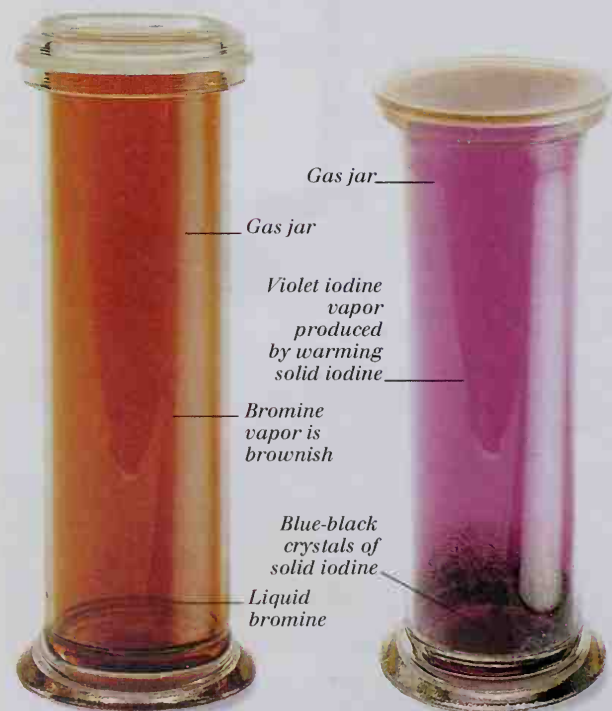

BROMINE

IODINE

POSITION IN THE PERIODIC TABLE

The diagram shows the periodic table with the elements in Group 17 (fluorine, chlorine, bromine, iodine, and astatine) highlighted in red. The elements are located in the second, third, fourth, fifth, and sixth periods of the p-block.

GROUP 17 ELEMENTS

The halogens form group 17 of the periodic table. They are (top to bottom): fluorine (F), chlorine (Cl), bromine (Br), iodine (I), and astatine (At).

PREPARATION OF CHLORINE

Chlorine gas, Cl_2 , is prepared in the laboratory by the oxidation of hydrochloric acid, HCl, using manganese(IV) oxide, MnO_2 . The chlorine produced contains some water vapor, but is dried by passing it through concentrated sulfuric acid, H_2SO_4 . In order to prevent this acid being sucked back into the reaction vessel, an empty dreschel bottle is placed between the acid bottle and the vessel to act as an anti-suck-back device (see p. 85). The dry gas is collected in a gas jar. Chlorine gas is poisonous.

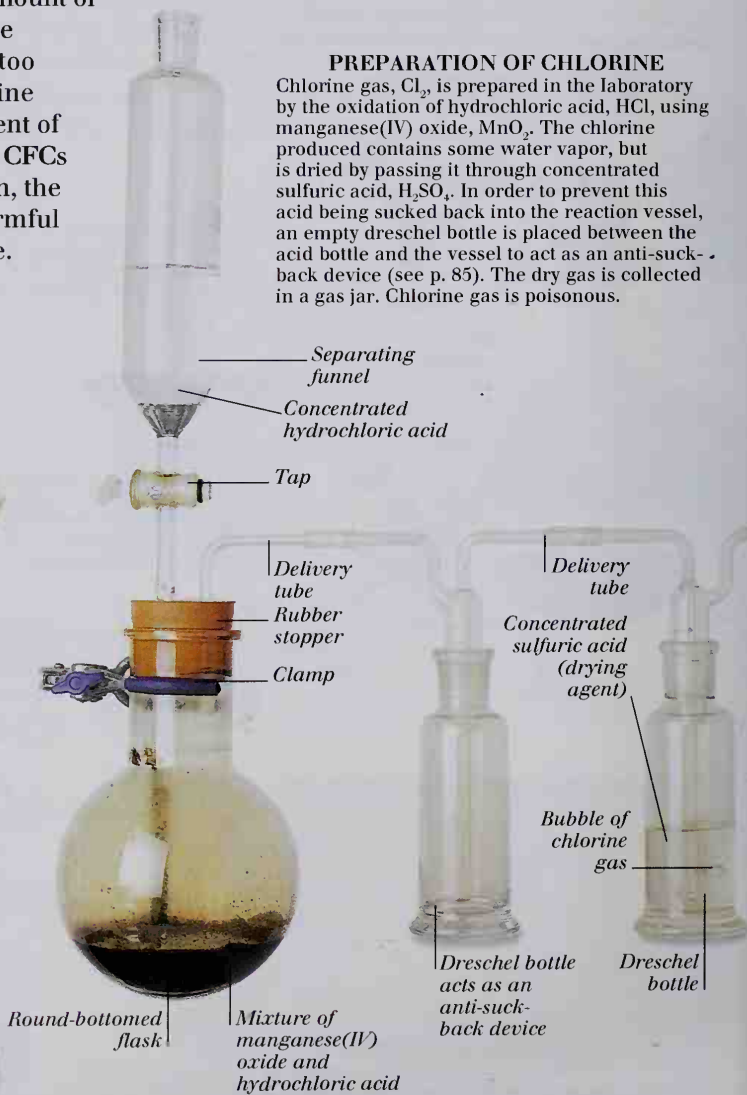

CHLORINE IN WATER



CHLORINE TEST KIT

Water can be tested for its chlorine concentration using kits such as this one. Chlorine in the water forms colored complex ions when a tablet is added, and the intensity of the color reveals the chlorine concentration.

BLEACHING



BLEACHING ACTION OF SODIUM HYPOCHLORITE

Sodium hypochlorite, NaOCl, is an industrially important chlorine compound that is a strong oxidizing agent. It bleaches pigments by giving up its oxygen to them, making them colorless.

Chlorine is a greenish yellow gas at room temperature

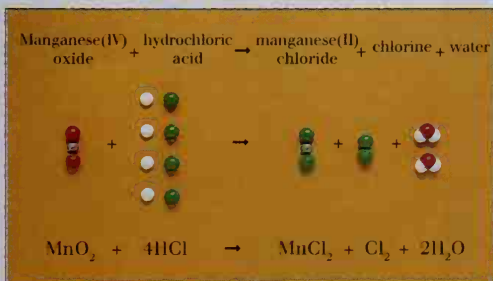

MOLECULAR VIEW

Four units of the hydrochloric acid are oxidized by each molecule of manganese(IV) oxide. The manganese(IV) is reduced to manganese(II).

OZONE DEPLETION REACTIONS

CFCs, synthetic organic compounds containing chlorine and fluorine atoms, have been used in packaging and some aerosol cans. Released into the atmosphere, CFCs lose chlorine atoms. These atoms catalyze reactions that damage the ozone layer, which shields the Earth from harmful solar radiation.

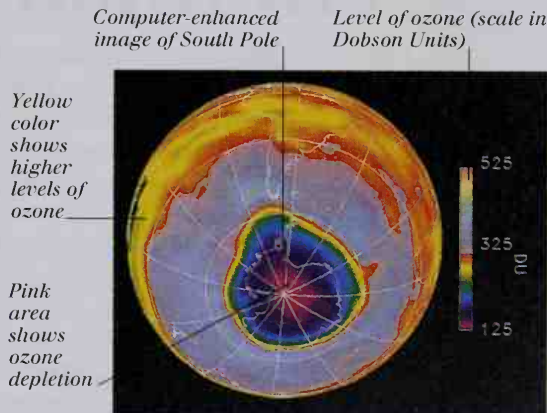

DEPLETION OF THE OZONE LAYER

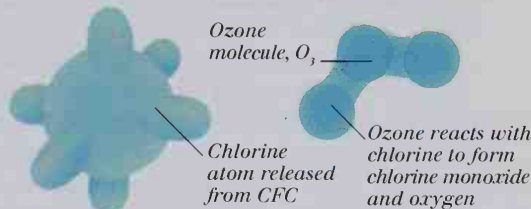

CHLORINE AND OZONE

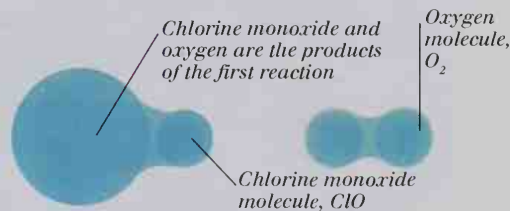

CHLORINE MONOXIDE AND OXYGEN

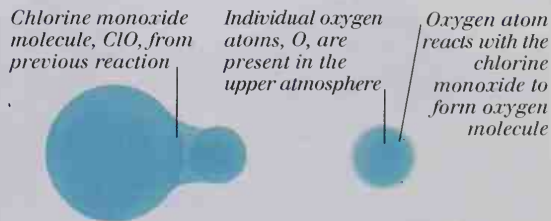

CHLORINE MONOXIDE AND OXYGEN

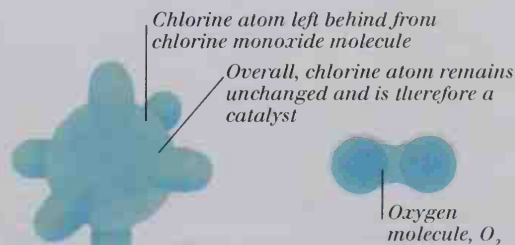

CHLORINE AND OXYGEN

Organic chemistry 1

ORGANIC CHEMISTRY IS THE study of carbon compounds, although it normally excludes carbon dioxide and salts such as calcium carbonate (see pp. 86-87). There are more carbon-based compounds than compounds based on all the other elements put together. This is because carbon atoms easily bond to each other, forming long chains and rings that include single bonds, double bonds (see p. 79), and triple bonds. Hydrocarbons are molecules containing only carbon and hydrogen. There are three main families of hydrocarbons based on carbon chains, called alkanes, alkenes, and alkynes (right). Ethyne is the simplest alkyne, with two carbon atoms. Most carbon compounds occur in different structural forms, or isomers. For example, the hydrocarbon butene has two isomers that differ in the position of the double bond. Crude oil is a mixture (see pp. 70-71) of long-chain hydrocarbons, which is separated industrially in a fractionating tower, and cracked (heated with a catalyst) to produce more useful short-chain compounds.

PREPARATION OF ETHYNE

Ethyne, C_2H_2 , a gas at room temperature, is the simplest alkyne. It is prepared by the exothermic reaction of water with calcium carbide, CaC_2 . Like all hydrocarbons, ethyne burns to produce water and carbon dioxide. Soot (pure carbon) may be formed due to incomplete burning.

Particles of soot

Ethyne burns in a flame, producing water vapor and carbon dioxide

Ethyne is a colorless gas

Glass tube

Calcium carbide, CaC_2 , is a brown ionic solid

Watch glass

CALCIUM CARBIDE

Calcium carbide, CaC_2 , is an ionic solid that contains the Ca^{2+} and C_2^{2-} ions. In ethyne, the product of the reaction, carbon and hydrogen atoms are covalently bound.

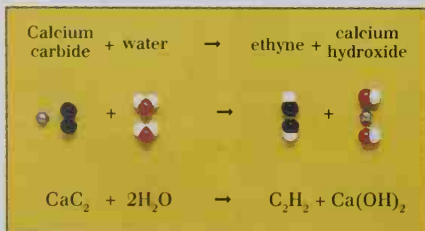

MOLECULAR VIEW

Carbon atoms from calcium carbide combine with hydrogen atoms from water molecules to form ethyne.

FAMILIES OF HYDROCARBONS
Alkanes have only single bonds in the chain of carbon atoms. Alkenes have at least one double bond in the chain, while alkynes have a triple bond.

ALKANES

Tetrahedral shape
Carbon atom
Hydrogen atom
Single bond

METHANE

ETHANE

Propane has three carbon atoms

Butane has four carbon atoms

PROPANE

BUTANE

ALKENES

Ethene has two carbon atoms
Double bond
Propene has three carbon atoms

ETHENE

PROPENE

Double bond is first bond in chain
Butene has two isomers
Butene has four carbon atoms
Double bond is second in chain

BUT-1-ENE

BUT-2-ENE

ALKYNES

Triple bond
Ethyne
Propyne exists in one form only

ETHYNE

Triple bond
Single bond

PROPYNE

Triple bond is second bond in carbon chain

Butyne has two isomers

Triple bond is first bond in carbon chain

BUT-2-YNE

Triple bond is first bond in carbon chain

BUT-1-YNE

Rubber stopper
Ring stand

Boiling tube

Clamp

CaC_2 and H_2O become C_2H_2 and $Ca(OH)_2$

CATALYTIC CRACKING OF OIL

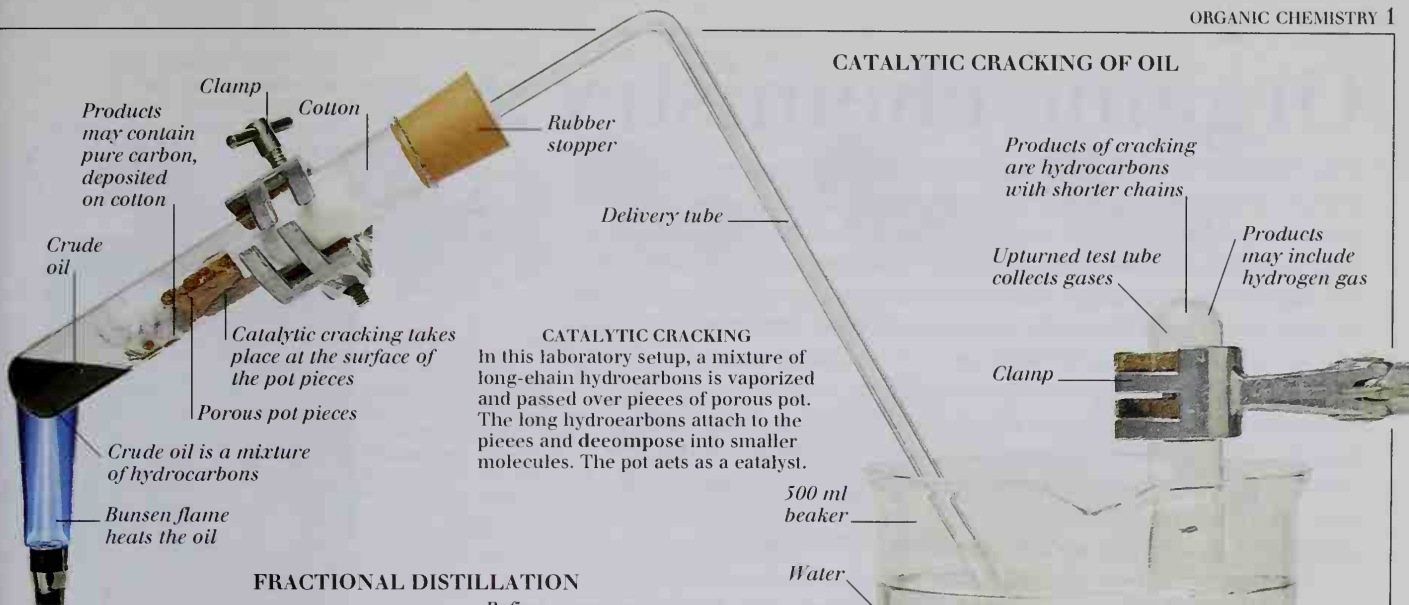

CATALYTIC CRACKING
In this laboratory setup, a mixture of long-chain hydrocarbons is vaporized and passed over pieces of porous pot. The long hydrocarbons attach to the pieces and decompose into smaller molecules. The pot acts as a catalyst.

FRACTIONAL DISTILLATION

FRACTIONAL DISTILLATION
Crude oil is made up of a mixture of hydrocarbons. This mixture is separated into fractions (groups of hydrocarbons with similar boiling points) by a process called fractional distillation. This process takes place in a fractionating tower. The oil is vaporized, and each fraction condenses to a liquid at a different temperature.

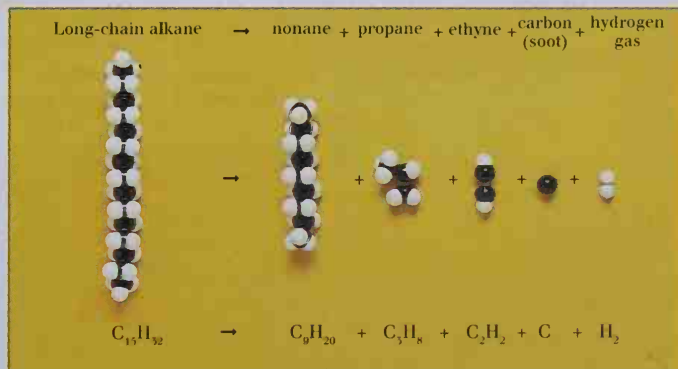
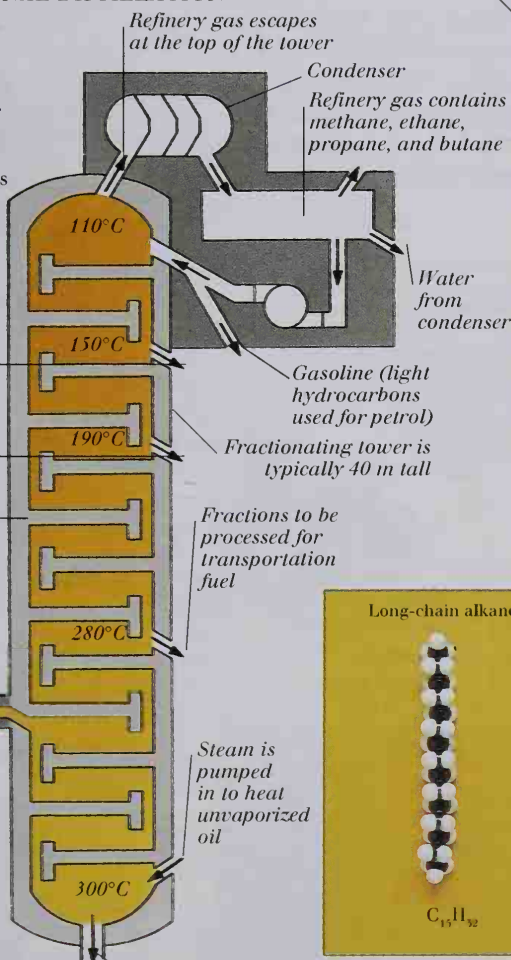

MOLECULAR VIEW

In the catalytic cracking of oil, hydrocarbon chains, shown here as 15 carbon atoms long, break into smaller chains with between 2 and 9 carbons. This is a molecular model of a general reaction. In reality, many other similar reactions are also likely to occur.

Organic chemistry 2

THE CHEMISTRY OF CARBON is called **organic chemistry**. Simple organic molecules (see pp. 112-115) are based on chains of carbon atoms. Carbon atoms are very versatile at bonding, and can form very large and complicated molecules. Small organic molecules often join together to form larger ones. For example, glucose, a simple sugar or monosaccharide, is a small organic molecule. Two saccharide units join to form a disaccharide, such as sucrose. Large numbers of sugar units can join to form polysaccharides such as starch (see p. 89). The process of joining large numbers of identical molecules together is called **polymerization**. The polymers that result are commonplace both in synthetic products and in nature. Plastics, such as nylon and PVC, are polymers, and much more complicated polymers form the basis of life. Hemoglobin is a large organic molecule responsible for carrying oxygen in red blood cells. DNA is a giant molecule that holds the genetic code in all living organisms. This code is created from patterns of four small molecules called bases, which are arranged along the famous double helix structure.

SUCROSE CRYSTALS
Sugars are carbohydrates. Sucrose (see p. 89) is the chemical name for ordinary household sugar. In this beaker, crystals of sucrose have formed from an aqueous solution of household sugar.

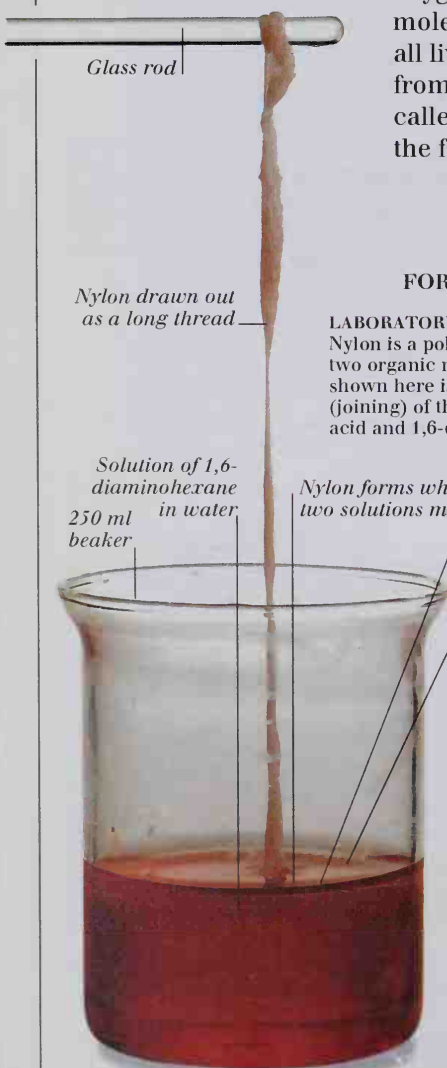
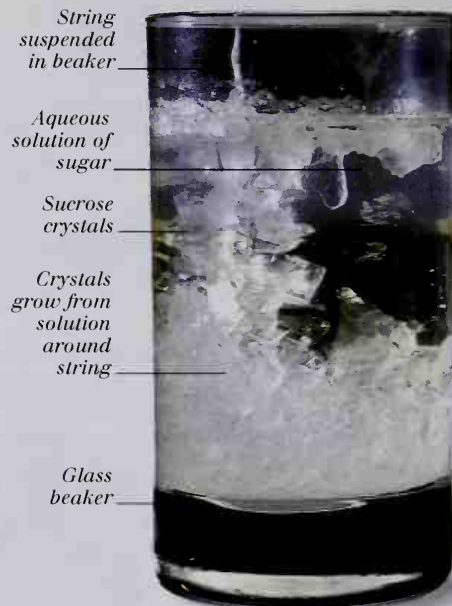

FORMATION OF NYLON

LABORATORY PREPARATION

Nylon is a polymer that is formed from two organic monomers. The form of nylon shown here is made by the synthesis (joining) of the monomers hexanedioic acid and 1,6-diaminohexane.

Nylon forms where two solutions meet

Layers do not mix because hexane does not dissolve in water

Solution of hexanedioic acid in hexane

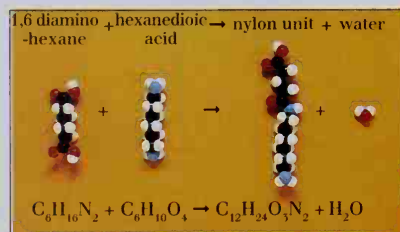

MOLECULAR VIEW

A unit of nylon is made from one molecule of each monomer (above). Each unit reacts again with one monomer at each end, eventually forming the polymer nylon. A nylon molecule may comprise hundreds of such units.

PLASTICS

Urea-methanal is a thermosetting plastic

Sample does not soften on heating

Porcelain evaporating dish



THERMOSETTING PLASTICS

Thermosetting plastics are molded when first made, and harden upon cooling. They cannot be softened again by heating.

Polyethylene is a thermoplastic material

Sample softens on heating

Porcelain evaporating dish



THERMOPLASTICS

Some plastics soften on heating. They can be remolded while hot, then allowed to cool and harden. Polyethylene is an example of such a thermoplastic.

POLYMERIZATION

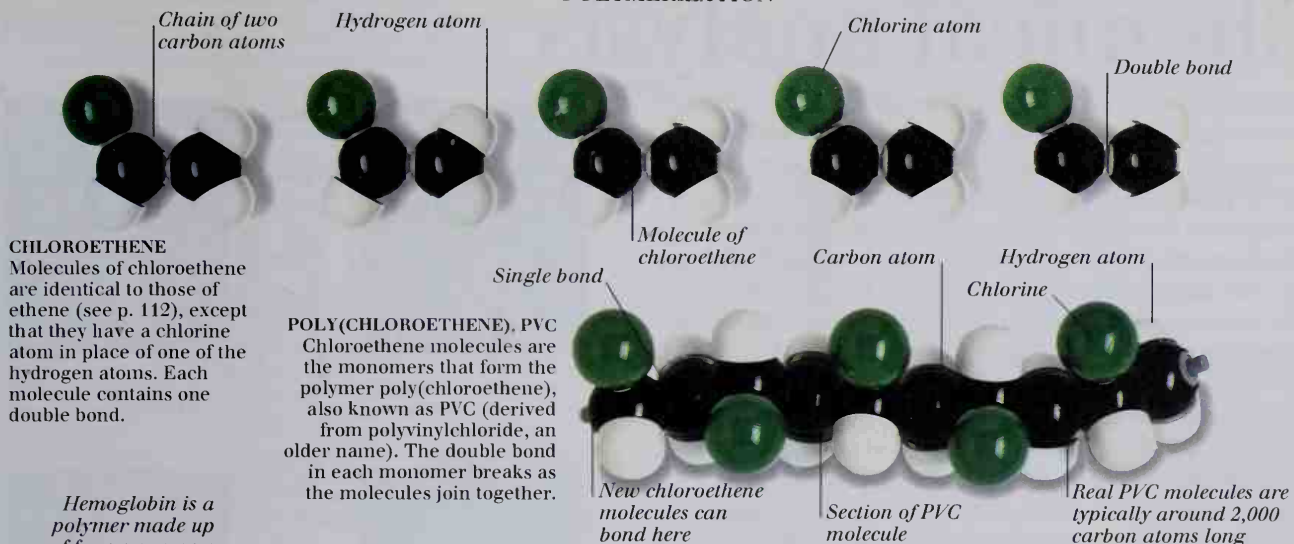

BIOCHEMISTRY

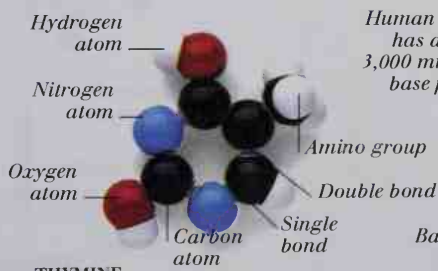
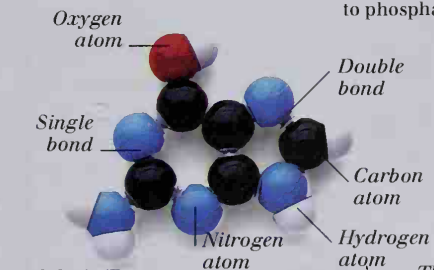
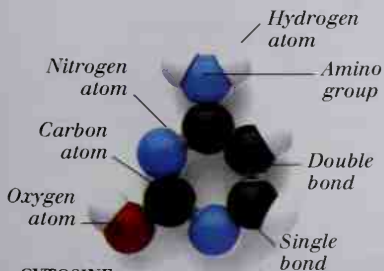
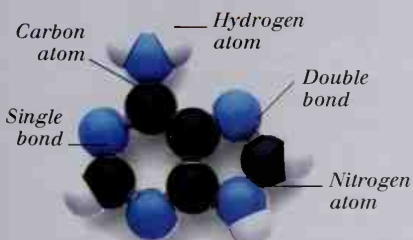
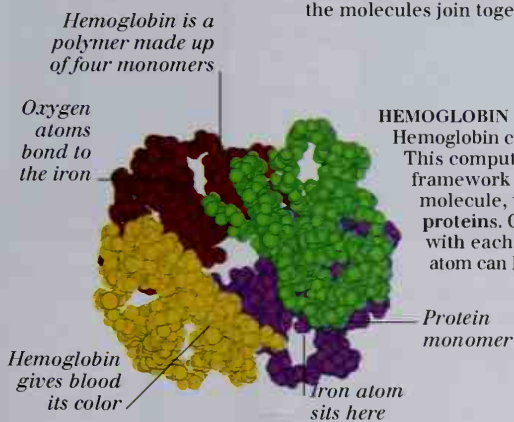

MODEL OF DNA STRUCTURE

This model shows the double helix structure of DNA (deoxyribonucleic acid). Pairs of the bases (below) link together and are held in place by a backbone of sugar units bonded to phosphate units, PO₄⁻.



Chemical analysis

THERE ARE MANY SITUATIONS, from geological surveys to forensic investigations, that call for the chemical analysis of unknown substances. The substances being analyzed may be present only in tiny amounts, and may be mixtures of many different compounds. Separation techniques such as chromatography (see pp. 70-71) are often the starting point in an analysis. Simple laboratory tests may follow – these normally identify one part of a compound at a time. For example, flame tests are used to identify cations of metallic elements in a compound, and radicals may be identified by heating the compound to decompose it, thereby releasing signifying gases. Many simple laboratory tests are performed on aqueous solutions of the unknown substance. The substance is crushed and dissolved in water, and other solutions, such as ammonium hydroxide or silver nitrate, are added. The color of any precipitate formed indicates the presence of a specific ion. In contrast, mass spectrometry is a highly complex but very powerful testing technique. The sample to be tested is vaporized, then ionized. The ions are separated by a strong magnetic field and identified according to their electric charge and mass.

FLAME TEST

A sample of an unknown compound is held on the end of a platinum wire in a Bunsen burner flame. Specific colors in the flame indicate the presence of certain metals.



CALCIUM
Compounds of calcium turn the flame orange-red.



LEAD
Lead salts give the flame a bluish white color.



POTASSIUM
Compounds of potassium turn the flame pale violet.



BARIUM
Barium salts turn the flame yellow-green.

TEST FOR A CARBONATE OR HYDROGENCARBONATE

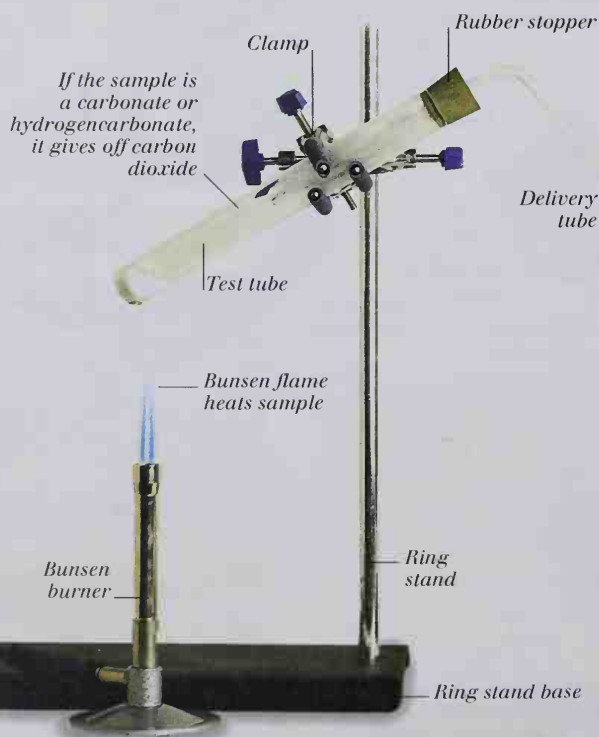

HEATING THE COMPOUND

A carbonate is a compound containing the carbonate radical, CO_3^{2-} – for example, calcium carbonate (see pp. 86-87 and 100-101). A hydrogencarbonate contains the hydrogencarbonate radical, HCO_3^- . When heated, these radicals give off carbon dioxide gas, which can be identified by bubbling it through limewater (a solution of calcium hydroxide).

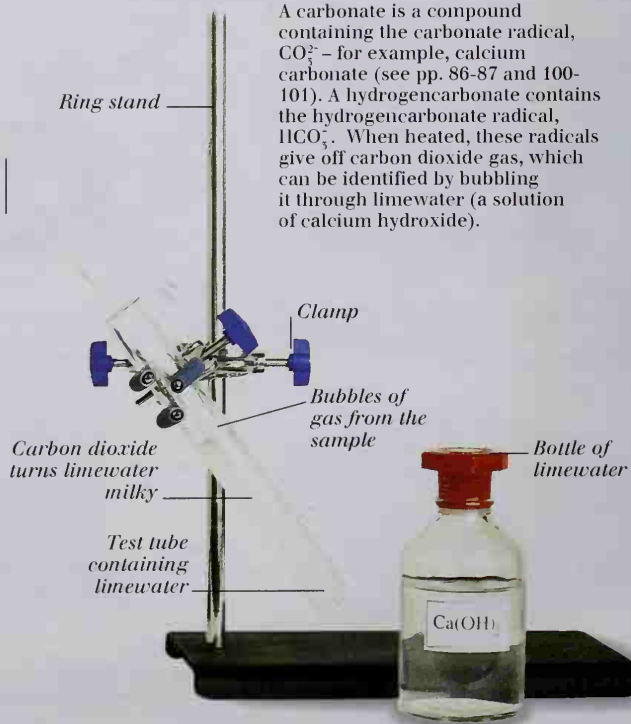

TESTING FOR CATIONS

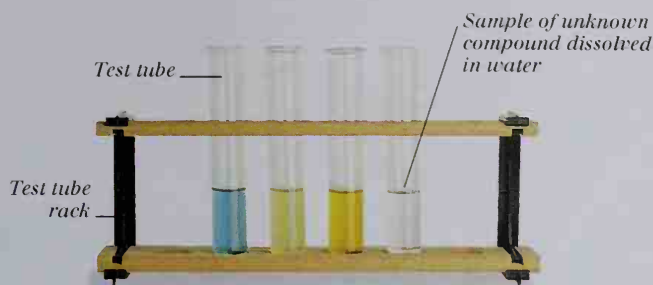

ACTION OF AMMONIUM HYDROXIDE

Many different tests are used to identify **cations** in an unknown compound. One simple test is carried out on a pure solution of the unknown compound in water. A dilute solution of ammonium hydroxide, NH_4OH , is added to the test solution. If a gelatinous precipitate forms, any cations present can often be identified by the color of the precipitate.

Pale blue precipitate that dissolves in excess NH_4OH to give deep blue solution indicates copper(II), Cu^{2+}

Gray-green precipitate indicates iron(II), Fe^{2+}

Red-brown precipitate indicates iron(III), Fe^{3+}

White precipitate may indicate magnesium, lead, zinc, or aluminum cations

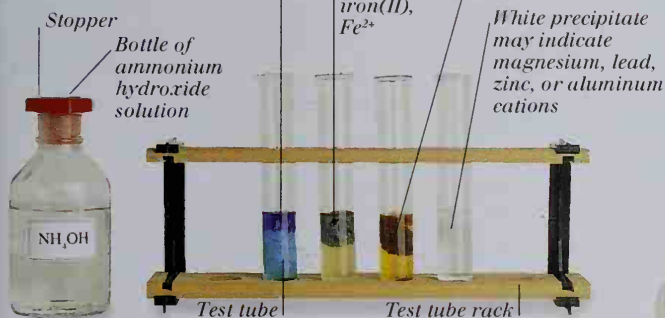

TEST RESULTS

A few solutions have been tested, and precipitates have formed in the test tubes. From the color of the precipitates, the metal cations present in the samples have been identified.

MASS SPECTROMETER

In a mass spectrometer, the sample to be tested is vaporized, then converted into ions and shot into a curved tube. A magnetic field in the tube deflects those ions with a specific mass and charge into a detector. Changing the magnetic field strength allows a mass spectrum – an analysis of all the ions present – to be built up, from which the test substance can be accurately identified.

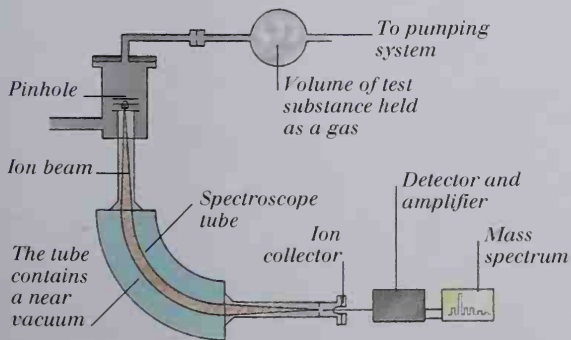

TESTING FOR ANIONS

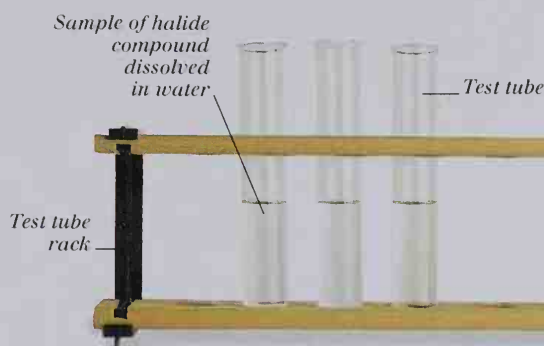

ACTION OF SILVER NITRATE SOLUTION

Of the many different tests used to identify **anions** in an unknown compound, the addition of aqueous silver nitrate, AgNO_3 , to an aqueous solution of the compound is often the first step. If halide ions – ions of the halogens (see pp. 110-111) – are present in solution, a colored precipitate forms.

White precipitate indicates that the compound contains chloride ions

Pale yellow precipitate indicates that the compound contains bromide ions

Yellow precipitate indicates that the compound contains iodide ions

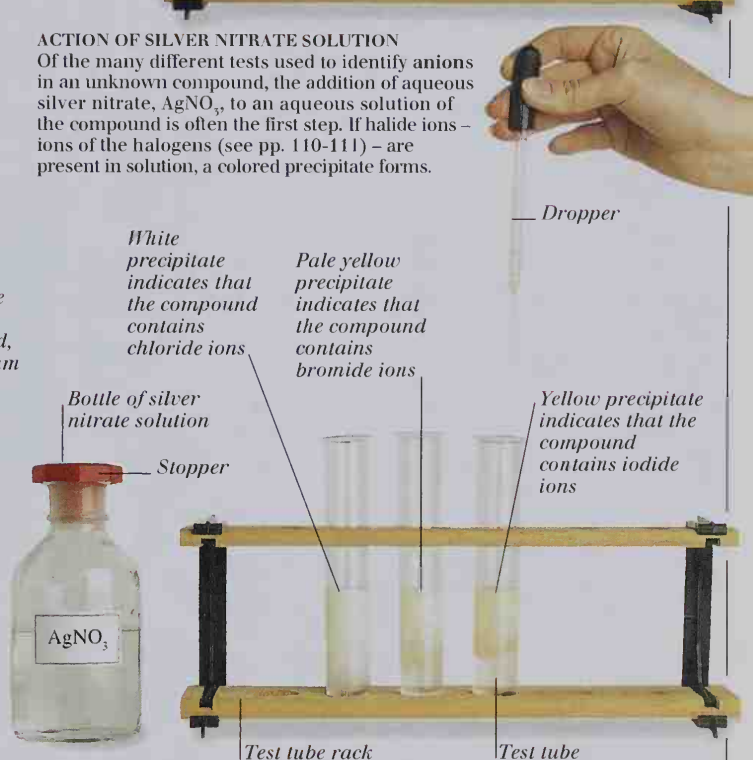

TEST RESULTS

Here, solutions of compounds containing ions of the halogens chlorine, iodine, and bromine have been tested. Salts containing ions of the halogens are called halides. Precipitates have formed in the test tubes.

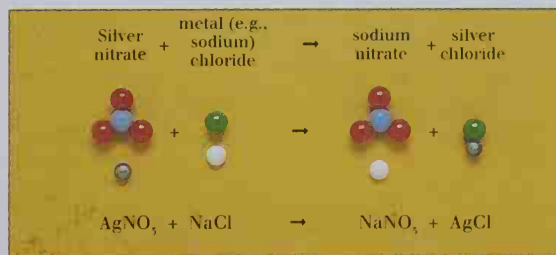

MOLECULAR VIEW OF REACTION

A double decomposition reaction takes place between silver nitrate and the halide salt in solution, and insoluble silver halides form. Silver halides are used in photography (see p. 88).



Two venomous gaboon vipers lie camouflaged in leaf litter



LIFE SCIENCES AND ECOLOGY

DISCOVERING LIFE SCIENCES AND ECOLOGY	120
CELLS AND CELL STRUCTURE	122
CELL FUNCTIONS	124
REPRODUCTION AND HEREDITY	126
EVOLUTION	128
CLASSIFICATION 1	130
CLASSIFICATION 2	132
MICROORGANISMS	134
FUNGI	136
NONFLOWERING PLANTS 1	138
NONFLOWERING PLANTS 2	140
FLOWERING PLANTS 1	142
FLOWERING PLANTS 2	144
FLOWERING-PLANT REPRODUCTION	146
PHOTOSYNTHESIS AND PLANT-TRANSPORT SYSTEMS ..	148
ECHINODERMS, SPONGES, AND CNIDARIANS	150
WORMS AND MOLLUSKS	152
ARTHROPODS 1	154
ARTHROPODS 2	156
FISH	158
AMPHIBIANS	160
REPTILES	162
BIRDS	164
MAMMALS	166
ECOLOGY	168
ENERGY FLOW AND FOOD WEBS	170
NATURAL CYCLES	172
HUMAN IMPACT ON THE ENVIRONMENT	174

Discovering life sciences and ecology

LIFE SCIENCE (ALSO CALLED BIOLOGY) is the science of living organisms. Ecology is the study of how living organisms relate to each other and to their environment, which includes nonliving matter. For most of history, the study of biology has been affected by religious or spiritual beliefs, such as the idea that matter becomes living through the influence of some kind of "living force." A more scientific approach to biology has resulted in the modern, more complex understanding of the processes of life.

EARLY STUDIES OF NATURE

Agriculture gave people practical, first-hand knowledge of plants and animals. However, there was little systematic study of living things until the rise of ancient Greece. The most influential Greek thinker was Aristotle. He devised a system of animal classification, while one of his pupils, Theophrastus, constructed a similar classification of plants. Some parts of Aristotle's work would seem crude by today's standards, but many of his ideas were advanced and played an important role in the development of the modern theory of evolution. For all their careful observation, the ancient Greeks could never have made more than clever guesses about the processes of life. Without microscopes, they could not even begin to grasp the intricacies of cell theory or be aware of the existence of microorganisms.

BIOLOGY AS A SCIENCE

During the Middle Ages, Arab scholars translated the works of Aristotle and others and added a few ideas of their own. The accumulated knowledge reached Europe around the 15th century. This period saw the rise of sciences such as zoology and botany. Comparative anatomy was advanced by Renaissance artists, who studied the muscles, bones, and internal organs of animals and human beings. During the later part of the Renaissance, a school of thought called iatrochemistry looked to chemical reactions to explain the workings of plants and animals. This was the dawn of biochemistry.

THE MICROSCOPE

Biological science was given a boost by the invention of the microscope in the early 17th century. Perhaps the best-known discovery made with a microscope was the existence of microorganisms. It was Antony van Leeuwenhoek who

first observed single-celled organisms, in the 1670s. About ten years earlier, Robert Hooke had observed tiny spaces throughout a sample of cork, which he called "cells." Hooke did not realize that the cell was the basic unit of all living things. Much later, in the 20th century, the electron microscope revealed even smaller structures within cells.

ORIGIN OF SPECIES

As early as the 6th century BC, Anaximander of Miletus had proposed that life arose spontaneously in mud. According to Anaximander, the first animals to emerge were spiny fishes, which "transmuted" into other species. This idea remained prominent until the end of the 19th century, when several experiments began to cast doubt upon it. Two areas of study that were important in refuting the idea of spontaneous generation were classification and paleontology (the study of fossils). Modern classification is based on a system devised by Carolus Linnaeus during the 1730s. Comparison of species gave weight to the idea that species changed gradually and somehow adapted to their environment. The fossil record supported this idea. Georges Cuvier was the first naturalist to show how species change over thousands or millions of years. In the early 1800s, Jean-Baptiste de Lamarck suggested that organisms in one generation inherit characteristics from the previous generation. For example, giraffes have long necks because their ancestors had to stretch their necks to reach the treetops. His ideas were shown to be mistaken by Charles Darwin in the 1850s.

18TH CENTURY MICROSCOPE

Microscopes began to open up the world of the miniscule from about the mid-1500s. This microscope was made in London in about 1728. It used the tilted mirror at the bottom to reflect light onto a specimen mounted above it on a glass slide.





DNA MODEL

This model of DNA was made in the 1950s by James Watson and Francis Crick. It comprises a large number of repeated structures and represents the information needed to build and maintain a living organism, such as a human being.

EVOLUTION AND GENETICS

Darwin's great idea was natural selection – random variations in species' characteristics (mutation) coupled with competition for survival. He also put forward a more controversial idea – that humans evolved by natural selection from apes. For this reason, and because no one could find a biochemical mechanism for natural selection, Darwin's ideas were not accepted at first. The first step to finding the mechanism behind natural selection was taken in the 1860s, by **Gregor Mendel**. Through painstaking experiments, Mendel founded the science of genetics. He proposed a unit of heredity, which he

named the gene, and discovered the rules by which genes control inherited characteristics.

Mendel's work was not recognized until about 1900. By this time, cell biology was well

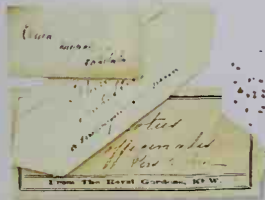
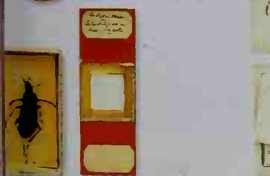

developed, but still no one could pinpoint the biochemical reactions by which Mendel's gene theory could work. Biochemistry was the key to genetics.

BIOCHEMISTRY

During the 19th century, the links between biology and chemistry became clearer. In the 1840s and 1850s, **Claude Bernard** laid the foundations of modern biochemistry during experiments on the pancreases of rabbits. Around the same time, scientists realized that the functions of living things depended upon the transfer of energy by chemical reactions. By the 1860s, scientists had realized that life on Earth depends upon energy from the Sun. Embryology (the study of fertilized eggs) also played an important role in biology during the 19th century. A biochemical approach to embryology led eventually to the discovery of the chemicals involved in Mendel's genetics. Perhaps the greatest achievement of this approach was an understanding of chemicals called nucleic acids, vital to genetics and the production of proteins within the cell. The structure of the most famous nucleic-acid molecule, DNA, was worked out in 1953. The genes that Mendel had hypothesized are lengths of DNA, which passes hereditary information from generation to generation.

ECOLOGY AND THE ORIGIN OF LIFE

The study of how populations of plants or animals change is central to ecology. The factors affecting populations include famine, disease, and – when applied to humans – war. Ecologists today use complicated mathematical models to analyze populations of plants, animals, and human beings. The term "ecology" was coined by German zoologist **Ernst Haeckel**. He was one of a number of 19th-century scientists who believed that life originated simply by chance; from chemicals present on the early Earth. This idea was supported by several experiments performed during the 20th century. An example is the Miller-Urey experiment, in which complex organic chemicals were produced from mixtures of simpler elements and compounds. The origin of life on this planet remains an unsolved mystery, as does the possibility of life elsewhere in the universe.

DARWIN'S EQUIPMENT

Charles Darwin sailed aboard the *Beagle* from 1852 to 1856. During this period, he noticed many puzzling features of the plants and animals he encountered, which led him to formulate his theory of evolution. Shown here is a selection of the equipment he took with him on his voyage.

TIMELINE OF DISCOVERIES

	10,000 BC	The first farmers cultivate crops and domesticate livestock and dogs. They gain much practical knowledge about plants and animals
Anaximander considers life to have begun spontaneously from slime	520 BC	
	350 BC	Aristotle classifies about about 500 species of animals
The first compound microscopes are made. They enable important biological discoveries to be made	1609	
	1667	Antony van Leeuwenhoek observes microorganisms in pond water through his microscope
Nehemiah Grew identifies the different types of tissue in a plant	1682	
	1755	Carolus Linnaeus develops the first modern system of classification for living things
The process of photosynthesis is discovered (but not understood) by Dutch-born biologist Jan Ingen-Housz	1779	
	1812	Georges Cuvier attempts a classification of extinct species by studying the fossil record
The cell theory is developed. It states that all living things are made of cells	1839	
	1859	Charles Darwin publishes his theory of evolution by natural selection
Gregor Mendel discovers the laws of genetics	1860	
	1861	Viruses are discovered as a result of sophisticated filtering techniques that remove bacteria from biological samples
The work of Gregor Mendel is rediscovered by three researchers and made public	1900	
	1935	Hans Krebs discovers the cycle of energy production in cells. It is named the "Krebs cycle"
Electron microscopes are used for the first time to observe the cell, leading to the discovery of many new organelles (parts of the cell)	1945	
	1953	James Watson and Francis Crick discover the famous double-helix structure of the DNA molecule
Stanley Miller carries out an experiment that shows how important organic chemicals can form in a "soup" of chemicals that were found on the early Earth, indicating the possible origin of life	1954	
	1975	Genetic engineering begins, as American biologists Seymour Cohen and Herbert Boyer show how the DNA molecule can be cut and rejoined using enzymes
Genes from one animal are successfully transferred into another	1981	
	1984	Alec Jeffreys develops DNA fingerprinting, a method of identifying people from their DNA. It proves useful in forensic science
Human genome project begins in many countries. It aims to map in detail the position of all human genes (collectively known as the genome)	1990	

Cells and cell structure

ALL LIVING ORGANISMS are made of cells, self-contained units of life that require a constant supply of energy to maintain themselves. Some **organisms** consist of a single cell, others are made up of billions of cells. There are two main types of cells: eukaryotic and prokaryotic. Eukaryotic cells are found in plants, animals, fungi, and single-celled organisms called protists (see pp. 134-135). These cells have an outer membrane; a control center, called the nucleus, which contains the cell's operating instructions in the form of DNA (deoxyribonucleic acid); and a jellylike matrix, the cytoplasm, in which are found cell components called organelles ("little organs"). Each organelle carries out a specific task, and together organelles maintain the cell as a living entity. Prokaryotic cells, found in bacteria (see pp. 134-135), are small, simple cells that lack a nucleus and most organelles. Animal cells take in food to obtain energy to reproduce and grow (see pp. 124-125). Plant cells use structures called **chloroplasts** to make food for themselves by trapping the Sun's energy (see pp. 148-149).

STRUCTURE OF AN ANIMAL CELL

The typical cell shown below includes features common to all animal cells. The cell is surrounded by a flexible plasma membrane, through which food is taken in to provide the energy that keeps the cell alive. Within the

membrane is the nucleus, which controls cell activities, and the cytoplasm, which contains organelles, each of which has a particular function. There are many different types of animal cells.

TYPES OF ANIMAL CELLS

Differences in shape between types of animal cells reflect their individual functions. Thin and flattened **squamous epithelial cells**, for example, form a protective lining inside the mouth and elsewhere. Closely packed, spindle-shaped **smooth muscle cells**, found in the gut wall, contract (shorten) to squeeze food along the intestines.

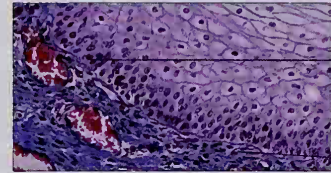

Nucleus

Cytoplasm

EPITHELIAL CELLS

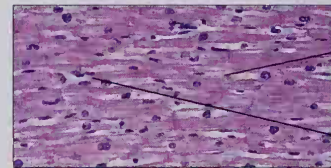

Cell membrane

Nucleus

SMOOTH MUSCLE CELLS

Plasma membrane separates the cell from its surroundings

Pinocytic vesicle enables the cell to engulf extracellular liquid

Endoplasmic reticulum makes and stores certain substances; it can be rough (studded with ribosomes) or smooth

Golgi body packages and transports secretory products, for example enzymes

Secretory vesicle (temporary structure that transports substances from the interior of the cell and deposits them on the outside)

Lysosome contains enzymes that break down foreign particles and damaged cell components

Mitochondrion carries out aerobic respiration to break down food and release energy

Nucleus (control center of the cell)

Nuclear membrane

Glycogen granules (long term storage form of glucose)

Cytoplasm forms a high proportion of the cell's volume

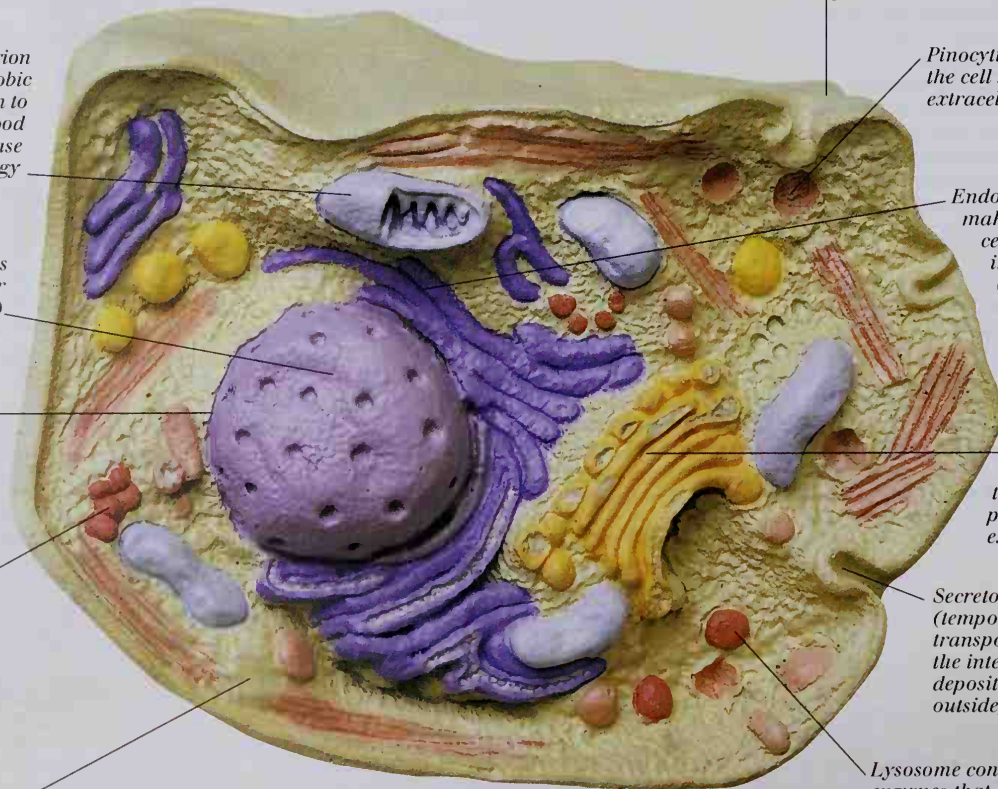

STRUCTURE OF A PLANT CELL

Plant cells share many characteristics with animal cells, but also show three main differences. Firstly, a plant cell is surrounded by a tough cell wall that gives it a definite shape, holds adjacent cells together, and helps to support the plant. Secondly, many plant cells contain organelles, called chloroplasts, which produce energy-rich food for the cell, using sunlight energy in a process called photosynthesis. Thirdly, most plant cells contain a large vacuole – a membrane-bound space filled with watery cell sap that helps cells maintain their shape. These features are illustrated in the typical plant cell shown here.



TYPES OF PLANT CELLS

Plants, like animals, contain different types of cells each with their own functions. Xylem cells are hollow, cylindrical, and dead. They carry water and mineral salts from the roots to other parts of the plant. Epidermal cells store food. The ones shown below, from the scale of an onion, store food. They lack chloroplasts because onion bulbs grow underground and do not need to photosynthesize.

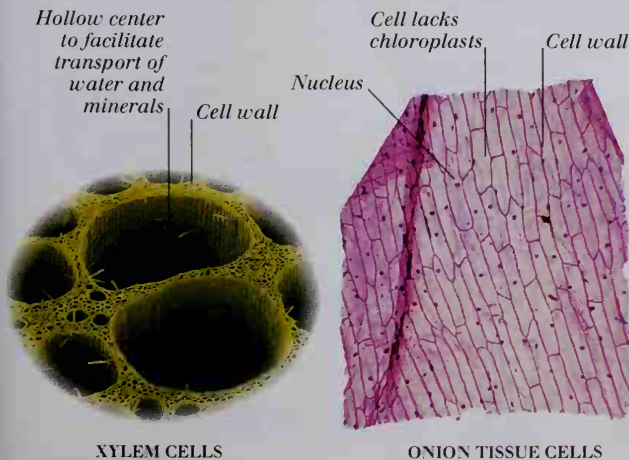

CELL ORGANELLES

Organelles are tiny cell components. Each type of organelle performs a particular function that contributes to keeping the cell alive. Organelles are under the control of the cell's nucleus. Most are surrounded by a single or a double membrane.

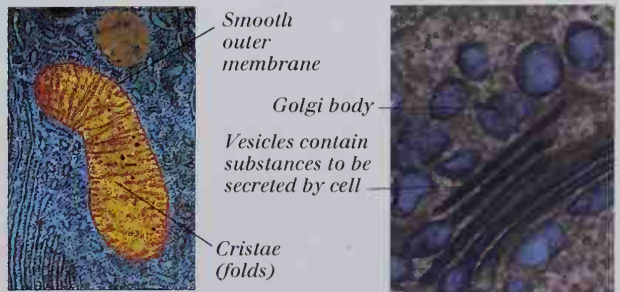

MITOCHONDRIA
Mitochondria use aerobic respiration to release energy from food molecules (see pp. 124-125). This happens on the cristae – the folds of the inner of the mitochondrion's two membranes.

GOLGI BODY
The Golgi body packages substances that are destined to be secreted by the cell. Small pieces break off and release their contents at the cell's surface.

Cell functions

EVERY CELL IS A LIVING CONTAINER in which hundreds of chemical reactions – known collectively as **metabolism** – take place. These are accelerated and controlled by **catalysts** called **enzymes**. The activity of each enzyme depends on its shape, which is controlled by the specific sequence of **amino acids** that form its **protein structure**. The instructions that specify the order of amino acids inside each protein are found in the molecules of **DNA** (deoxyribonucleic acid) in the cell's **nucleus**. Strands of **RNA** (ribonucleic acid) copy and carry these instructions, through the nuclear envelope, to the site of protein synthesis in the **cytoplasm**. By controlling protein synthesis, DNA controls enzyme activity and thereby every aspect of cell function. Respiration releases the energy needed for protein synthesis from food and stores it as **ATP** (adenosine triphosphate) – a molecule that can be readily used by the cell for its energy needs.

METABOLIC REACTIONS IN A CELL

Metabolism is the sum total of all the chemical reactions taking place inside the cells of an organism. These reactions are accelerated, or catalyzed, by biological catalysts called **enzymes**. **Anabolic reactions** use raw materials taken in by the cell to make more complex molecules, such as the proteins and phospholipids that are used in the construction and metabolic reactions of the cell. Anabolism requires energy, released by **catabolic reactions** such as respiration, which breaks down energy-rich molecules, such as glucose, to release their energy.

Food enters cell from the outside
A single cell
Building molecule – simple amino acid

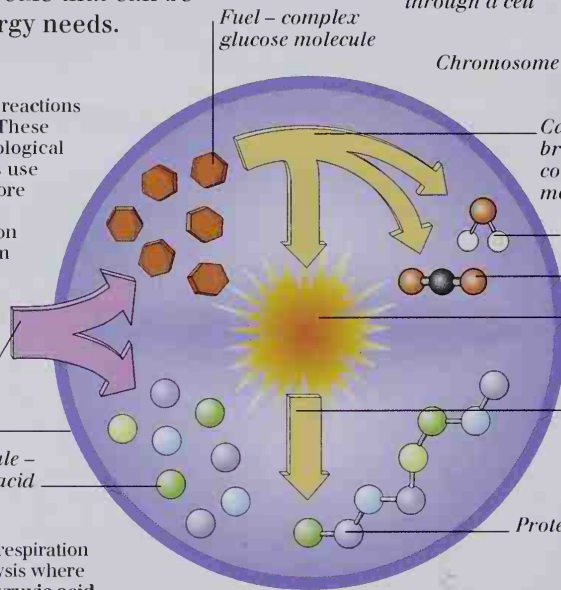

ENERGY YIELD OF RESPIRATION

Aerobic respiration requires oxygen, anaerobic respiration does not, both have an initial stage called **glycolysis** where glucose is broken down into two molecules of **pyruvic acid**. This yields 2 ATP during anaerobic respiration and 8 ATP during aerobic respiration, with a further 30 ATP when pyruvic acid is broken down by the **Krebs cycle** inside **mitochondria**.

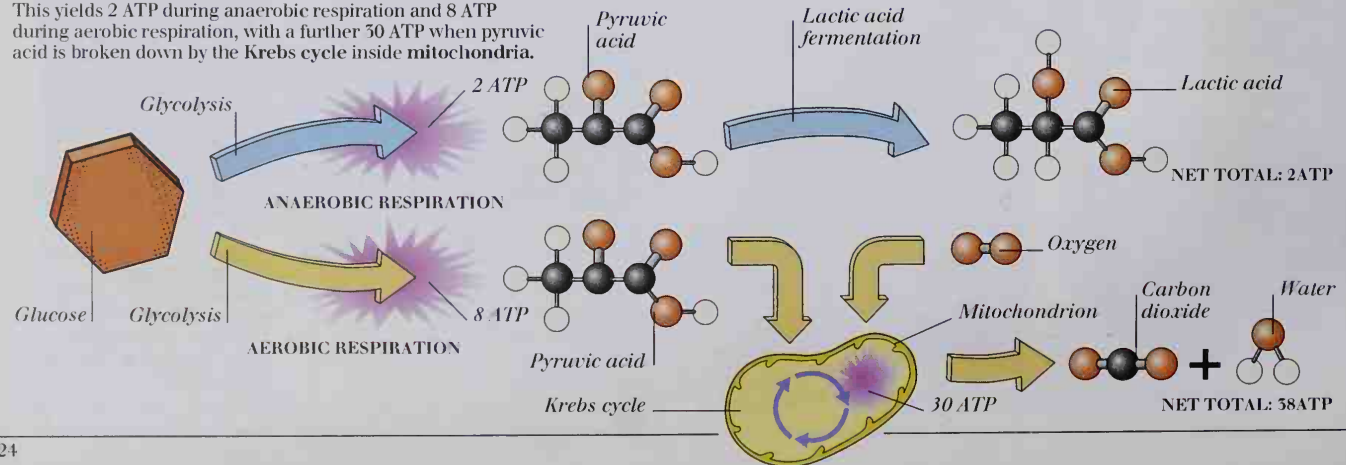

PROTEIN SYNTHESIS

Protein synthesis occurs in the cytoplasm, using instructions from DNA in the nucleus. DNA is divided into genes. The bases in each gene are arranged in precise order. The cell uses a genetic code that reads one codon (three bases) at a time. Each codon specifies an amino acid; the sequence of codons specifies the amino acids that make a particular protein. Protein synthesis has two stages: transcription and translation.

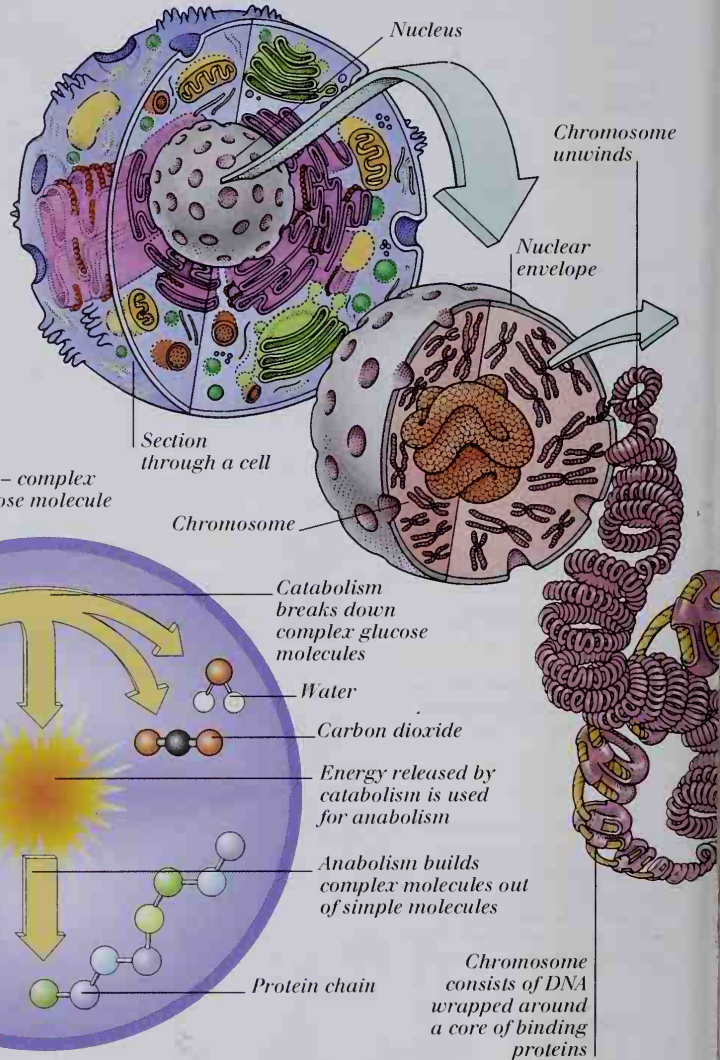

TRANSCRIPTION

During transcription, the two strands of DNA "unzip," exposing a section of the DNA molecule that makes up one gene. The bases on this DNA strand act as a template to make messenger RNA (mRNA). RNA nucleotides line up to match complementary bases on the DNA strand. The RNA nucleotides are linked to form a strand of mRNA. This copy of the DNA base sequence then passes from nucleus to cytoplasm through a pore in the nuclear envelope.

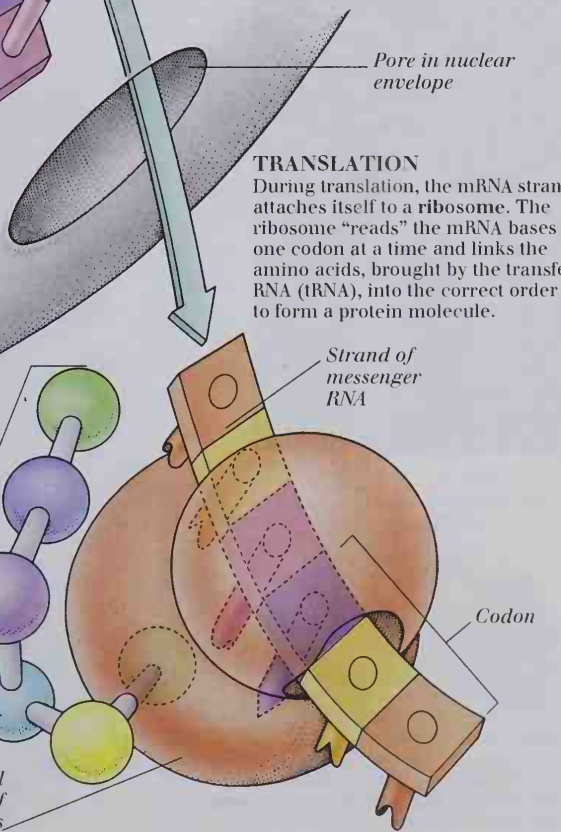
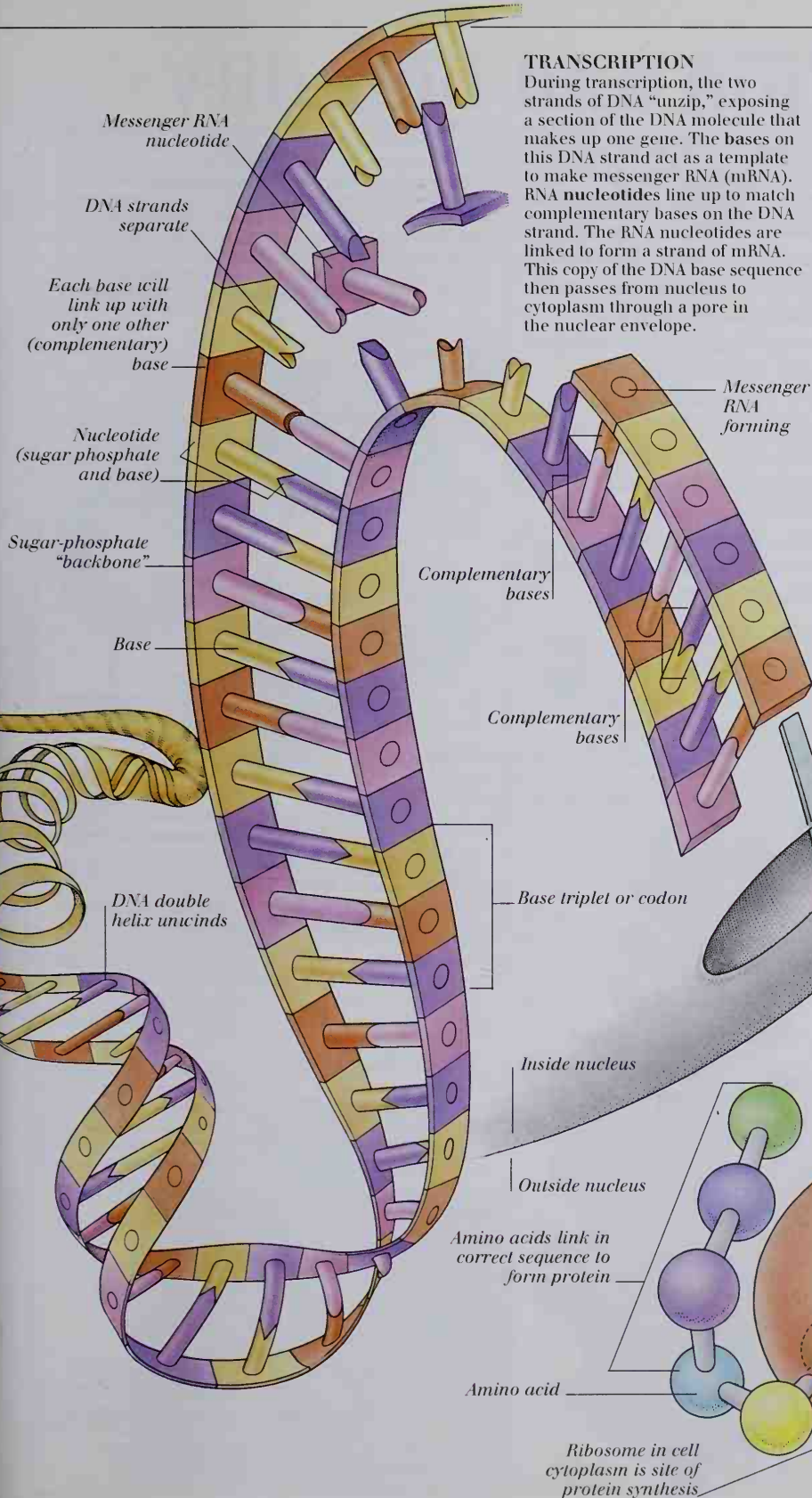
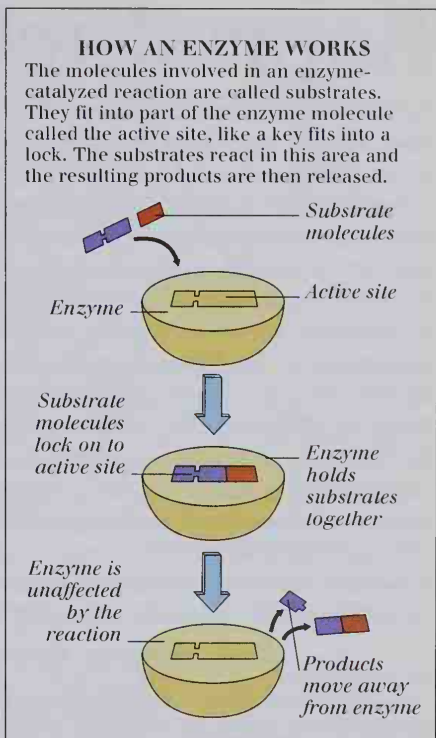

TRANSLATION

During translation, the mRNA strand attaches itself to a ribosome. The ribosome "reads" the mRNA bases one codon at a time and links the amino acids, brought by the transfer RNA (tRNA), into the correct order to form a protein molecule.

Reproduction and heredity

LIVING ORGANISMS MUST REPRODUCE to ensure that their species does not die out. There are two types of reproduction: asexual reproduction, which involves a single parent and produces offspring with the same **genotype** as the parent; and sexual reproduction, which involves the fusing of sex cells from two parents to produce a new individual with a different genotype. Heredity explains the way that genes are passed from one generation to the next during sexual reproduction. This was first described by the Austrian monk, Gregor Mendel (1822-84). By breeding pea plants, he showed that parental traits did not blend in offspring, but remained separate, and were controlled by factors (**genes**) that occurred in pairs. There are two or more forms (**alleles**) of each gene: dominant alleles, which are always expressed in the offspring; and recessive alleles, which are expressed only if they occur in pairs. Mendel arrived at his conclusions by calculating the ratio of phenotypes (visible characteristics) shown by offspring of known parents.

ASEXUAL REPRODUCTION

HYDRA BUDDING

Hydra sp. is a tiny freshwater cnidarian (see pp. 150-151) that reproduces asexually by budding. A small bud grows from the side of the hydra and soon develops tentacles to catch food for itself. Within days, it pinches itself off and begins an independent existence.



Parent hydra with tentacles

Bud attached to parent

Adventitious bud (detachable bud with adventitious roots) drops from leaf

ADVENTITIOUS BUDS

The Mexican hat plant (*Kalanchoe daigremontiana*) reproduces asexually by producing adventitious buds, miniature plantlets, which grow from meristematic (actively dividing) tissue located on the margin of leaves. When ready, these plantlets fall to the ground, take root in the soil, and grow into new plants.

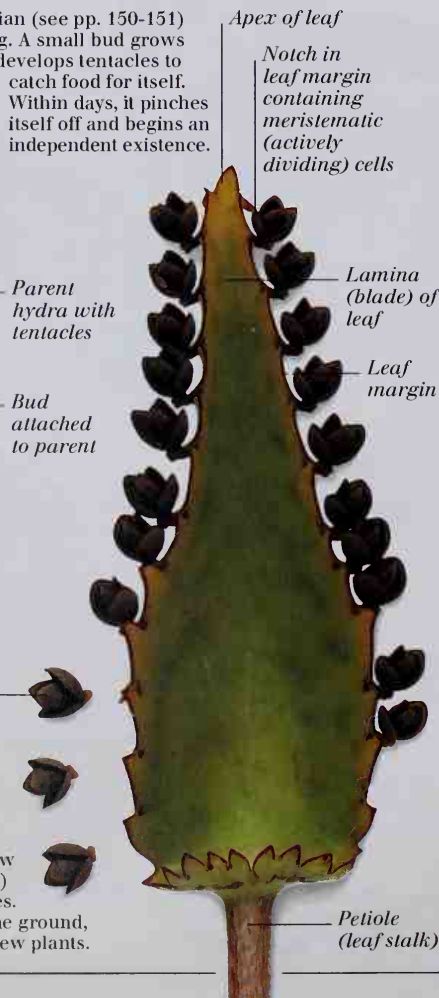

MITOSIS

Mitosis occurs during asexual reproduction and growth. It is a type of cell division that produces two new daughter cells that are genetically identical to the parent cell. Before division, each **chromosome** in the **nucleus** copies itself to produce two linked strands, or **chromatids**. These separate during mitosis, and one of each pair passes into a new daughter cell.

Chromosomes get shorter inside nucleus

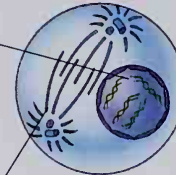

Spindle begins to form

EARLY PROPHASE OF MITOSIS

At the beginning of mitosis, chromosomes tighten (condense), and a framework of tiny tubes (the spindle) begins to develop.

Pole of spindle

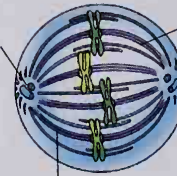

Nuclear envelope breaks down

METAPHASE

The chromosomes line up across the center of the spindle.

Chromosome

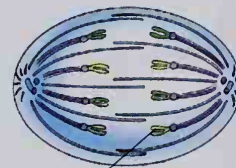

ANAPHASE

The chromatids that make up each chromosome move apart and travel to opposite ends of the spindle.

Chromatid

Cytoplasm divides

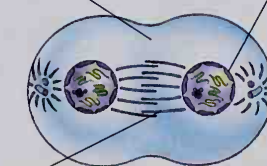

Nuclear envelope forms

TELOPHASE

A nuclear envelope surrounds each set of chromatids, forming a new nucleus. The cytoplasm then begins to divide.

Spindle begins to disappear

Nucleus



Chromosomes become longer and thinner

INTERPHASE

Once cell division is complete, the chromosomes unwind. The two new cells now have identical genetic material.

Identical daughter cell

SEXUAL REPRODUCTION AND HEREDITY

MEIOSIS

Meiosis is the type of cell division that produces gametes (sex cells), such as sperm and ova (eggs), which are used in sexual reproduction. Most of the cells that make up an organism are diploid – they have two sets of chromosomes in the nucleus, one from each of the organism's parents. The total number of chromosomes varies from species to species, but in every case the two sets consist of matching pairs of chromosomes, called homologous chromosomes. Meiosis consists of two divisions, during which a diploid parental cell produces four daughter cells, which are haploid – have one set of chromosomes – and are not identical to each other.

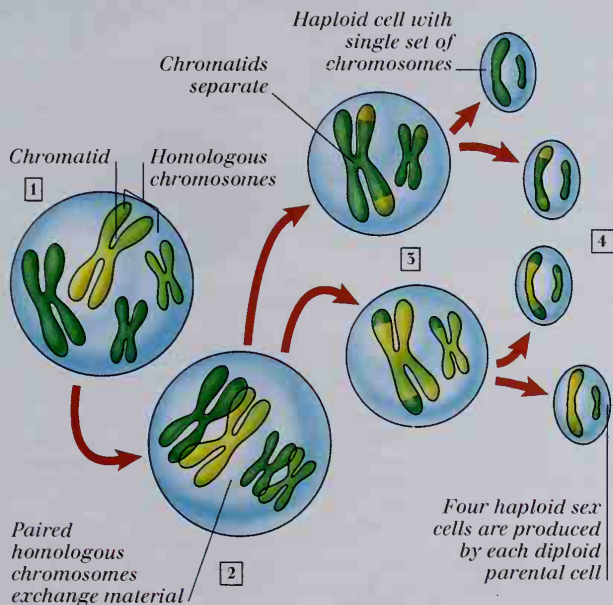

FIRST DIVISION

Each chromosome replicates and produces two linked chromatids (1). Homologous chromosomes swap genetic material (2), and two haploid cells are formed, each with one set of chromosomes (3).

SECOND DIVISION

The two chromatids in each chromosome separate and are pulled to opposite poles of the cells. Each cell divides to produce two daughter cells with single-stranded chromosomes (4).

MENDELIAN RATIO

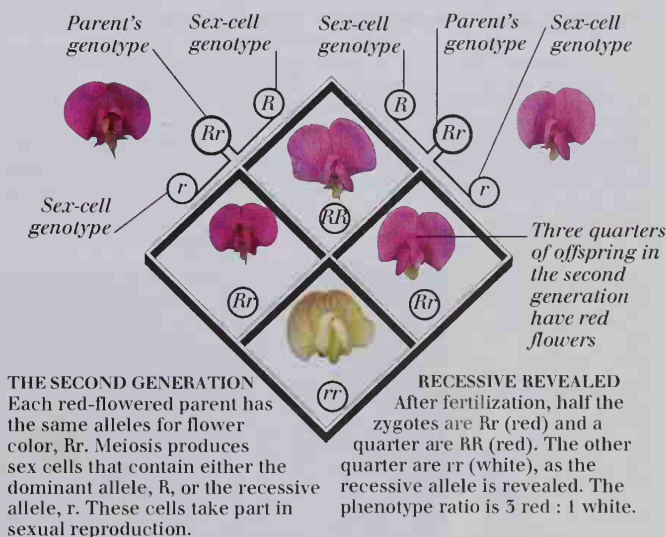
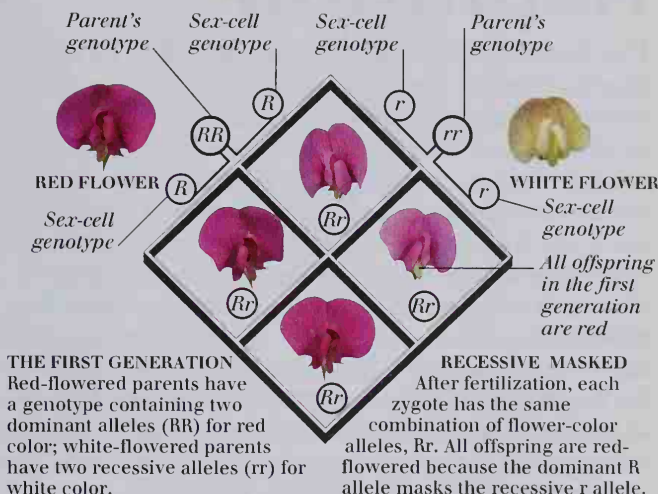

FERTILIZATION

Fertilization is the fusion of a male sex cell (sperm) and a female sex cell (ovum) to form a zygote (fertilized ovum). During fertilization, several sperm surround the ovum and use enzymes to

break through its outer covering – the zona pellucida. One sperm finally succeeds, and its nucleus, contained in the head of the sperm, fuses with the ovum's nucleus to form a zygote.



NATURAL VARIATION

Sexual reproduction results in offspring that are not identical to each other or to their parents. This natural variation occurs because each offspring inherits a slightly

different set of genes from each of its parents. Variation can be seen most obviously in differences between external features, such as coat color in these puppies.



Evolution

THE THEORY OF EVOLUTION was established by English naturalist Charles Darwin (1809-82) (see pp. 120-121). Evolution is the process whereby living things change with time. Within a species there is always variation; some individuals are more successful than others in the struggle for survival and are more likely to breed and pass on their advantageous characteristics. This process is called natural selection and is the driving force of evolution. It enables species to adapt to changing environments, and may, in time, lead to new species appearing. Since life began on Earth, millions of new species have appeared and become extinct. Organisms alive today represent only a small fraction of those that have ever existed. There is much evidence for evolution, including: the fossil record, which reveals ancestry; the current distribution of animals and plants; and modern examples of natural selection. Although evolution is a theory widely accepted by both scientists and nonscientists, some people believe that all living things were divinely created in their present form – this theory is known as creationism.

MISSING LINK

Some fossil finds have been of great importance because they have provided a “missing link” that shows how one major group has evolved from another. One such fossil is that of *Archaeopteryx*, which, with its long, bony tail, jaws with teeth, and claws on fingers, closely resembled small dinosaurs

called theropods. Like birds, it also had feathers and a forelimb adapted as a wing. It is likely, therefore, that *Archaeopteryx*, which probably glided from trees rather than flew, was a close relative of the ancestor of modern birds. The fossil also suggests that birds evolved from, and are the nearest living relatives of, the dinosaurs.

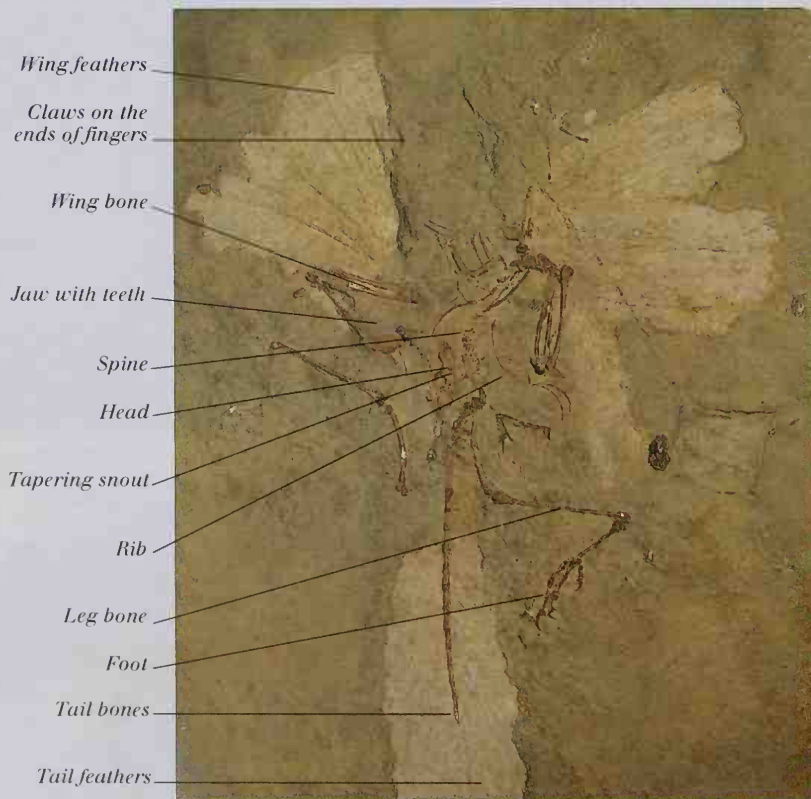

DARWIN'S FINCHES

This group of 13 finch species is found only on the Galápagos Islands, off the coast of Ecuador. Each has its own way of life, and a beak shape related to diet. When Charles Darwin observed this, he concluded that they had all evolved from a single, ancestral, South American species. This is an example of adaptive radiation – evolution from a single ancestor of many species, each exploiting different lifestyles.



NATURAL SELECTION

The peppered moth provides an example of natural selection in action. It rests on lichen-covered tree trunks, camouflaged from predatory birds by its pale color. In 19th-century industrial England, air pollution killed the lichen and blackened the tree bark with soot. Dark forms of the moth, which appeared as a result of natural variation, increased in number because they were better camouflaged against the darkened tree trunks.

Dark form of peppered moth



Pale form of peppered moth

PEPPERED MOTHS

FOSSIL EVIDENCE

Broad skull with mouth adapted to catching prey in water

Flexible backbone

Short tail



FOSSIL FROG

Fossils of early frogs reveal a newtlike animal with a flexible backbone that moved through the water with a fishlike side-to-side motion of its body and tail. They may also have kicked out with their hind legs to provide extra propulsion. Like modern frogs, they had a broad skull and a mouth adapted to catching prey in water.

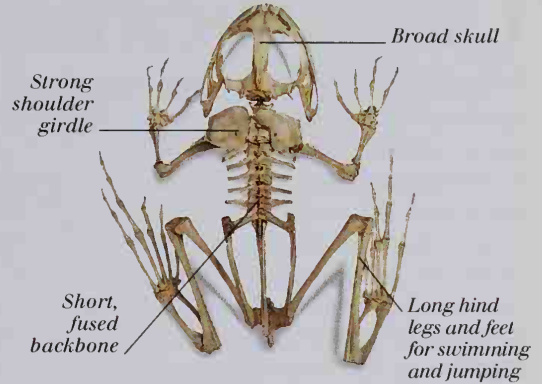

MODERN FROG

During their evolution, frogs became adapted to swimming and jumping using their long hind legs and feet. As a consequence, because their tails were no longer used, these were lost and their backbones became short and rigid. Strong shoulder girdles have also developed to resist the force of landing.

LIVING EVIDENCE OF EVOLUTION

An example of living evidence that supports evolution is the pentadactyl (five-fingered) limb. All mammals share the same arrangement of bones in the four limbs, which suggests they evolved from a common ancestor. Differences between species are a result of adaptation to different lifestyles. The chimpanzee arm has the basic pentadactyl pattern. The dolphin has short, thick arm bones and splayed hand and finger bones that form a powerful flipper. The bat's hand and finger bones are long and thin, forming a light but strong framework to support a wing.

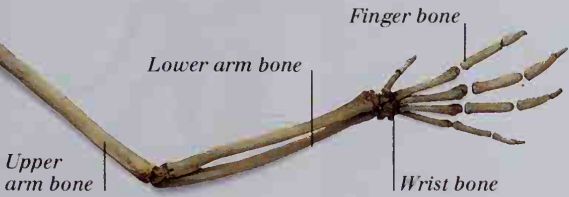

CHIMPANZEE ARM BONES

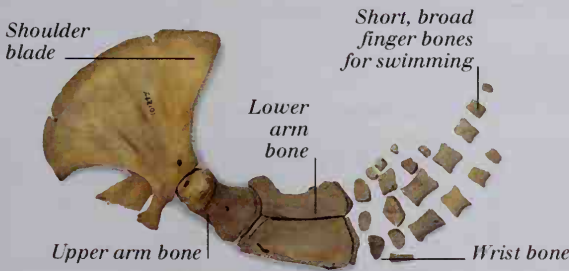

DOLPHIN FLIPPER BONES

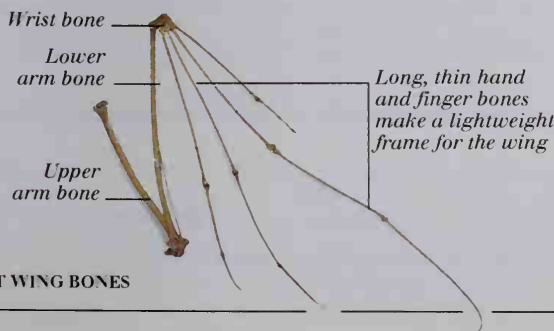

BAT WING BONES

HORSE EVOLUTION

The evolution of modern horses from a dog-sized ancestor called *Hyracotherium* took over 50 million years. It did not follow a single, straight line, but branched off in many directions and included genera that are now extinct. Four ancestors of the horse are shown below. *Hyracotherium* had splayed toes and was a forest dweller, as was three-toed *Mesohippus*. *Merychippus* lived in grasslands and walked on its middle toes. *Pliohippus* was also a grazer and, like modern horses, had a single toe ending in a hoof.

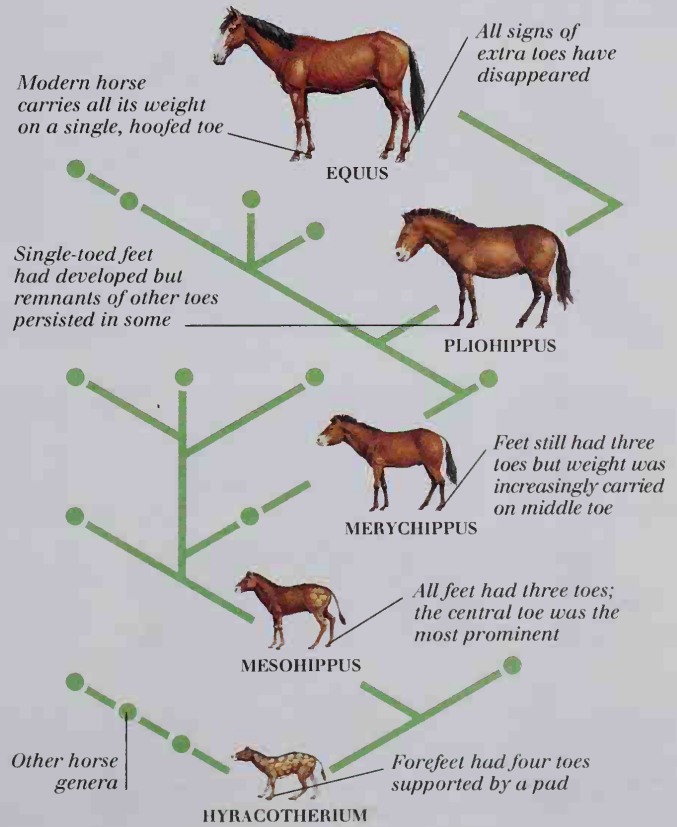

Classification 1

IN ORDER TO MAKE SENSE of the millions of species found on Earth, biologists classify them into a rational framework. Classification is used to identify and name individual species and to show how different species are related to each other. The Swedish naturalist Carolus Linnaeus (1707-78) (see pp. 120-121) devised the first rational system of classification, which is still used by biologists today. It groups different organisms together on the basis of their similarities and gives each species a Latin or latinized binomial (two-part) name. The first part identifies the genus (group of species) to which the organism belongs, and the second part identifies the species. Classification systems arrange species in groups (taxa). They are ranged in order of size from the smallest taxon – species – at the bottom, to the largest taxon – kingdom – at the top. Most systems of classification place living organisms into one of five kingdoms: monerans, protists, fungi, plants, and animals.

THE FIVE-KINGDOM SYSTEM



MONERA (BACTERIA)

The kingdom Monera contains bacteria, the simplest organisms on Earth. They are single-celled prokaryotic organisms and are found in every habitat (see pp. 134-135).



PROTISTA (PROTISTS)

The kingdom Protista is a diverse assemblage of single-celled, eukaryotic organisms. They include plantlike, animal-like, and fungilike organisms (see pp. 134-135).



FUNGI

Fungi are eukaryotic, mostly multicellular organisms that are typically made up of threadlike hyphae and reproduce by releasing spores from fruiting bodies (see pp. 136-137).



PLANTAE (PLANTS)

Plants are hugely diverse, multicellular, eukaryotic organisms whose cells have walls (see pp. 138-149). They make their own food by harnessing the Sun's energy during photosynthesis.



ANIMALIA (ANIMALS)

Animals are multicellular, eukaryotic organisms, whose cells lack walls (see pp. 150-167). They typically feed by ingesting food, which is then digested internally.

CLASSIFYING SPECIES

Species, such as the tiger, are classified by being placed in increasingly larger groups. The tiger is grouped into a genus (big cats); the family (cats) contains similar genera; families are grouped into an order (carnivores); related orders form a class (mammals); classes are grouped into a phylum (or division for plants) (chordates); and phyla that share broad characteristics collectively form a kingdom (animals).

KINGDOM: Animalia (animals)

Animals are multicellular organisms that move actively, respond to their surroundings, and feed by ingesting nutrients.

PHYLUM: Chordata (chordates)

Chordates are animals that have a notochord (a stiffening skeletal rod), a dorsal nerve cord, and gill slits at some stage in their life.

CLASS: Mammalia (mammals)

Mammals are chordates that are endothermic (warm-blooded), have hair or fur on their body, and suckle their young with milk.

ORDER: Carnivora (carnivores)

Carnivores are mammals that typically eat meat, are specialized for hunting, and have teeth adapted for gripping and tearing flesh.

FAMILY: Felidae (cats)

Cats are highly specialized predators. They have powerful jaws, and good vision and hearing.

GENUS: *Panthera* (big cats)

Big cats can roar and hold their prey with their forepaws while feeding.

SPECIES: *Panthera tigris* (tiger)

Tigers are the largest and most powerful of the big cats. Their striped coat provides camouflage.



TIGER
(*Panthera tigris*)

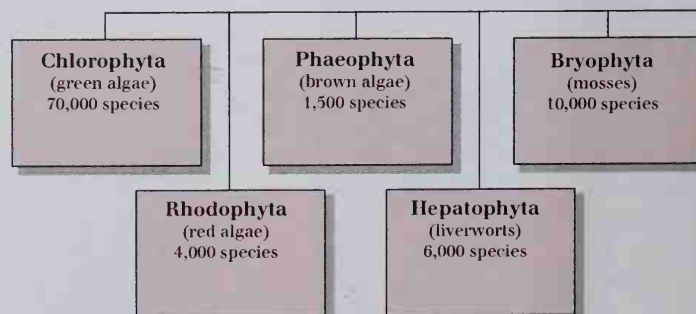

KEY

KINGDOM
 DIVISION
 CLASS

All figures given are a rough estimate of species numbers

CLASSIFYING MONERANS, PROTISTS, FUNGI, AND PLANTS

Kingdom Monera has two divisions: Archaeobacteria and Eubacteria . Kingdom Protista has 10 divisions grouped into fungilike slime and water molds (divisions Acrasiomycota, Myxomycota, Oomycota); animal-like protozoa (divisions Sarcostomastigophora, Ciliophora, Sporozoa); and plantlike algae (divisions Chrysophyta, Euglenophyta, Bacillariophyta, Pyrrophyta). The four divisions in kingdom Fungi are classified according to their means of reproduction; lichens are a symbiotic association

between fungi and algae. There are 15 divisions of kingdom Plantae: seaweeds (divisions Chlorophyta, Rhodophyta, Phaeophyta); nonvascular, spore-producing plants (divisions Hepatophyta, Bryophyta, Anthoceroophyta); vascular, spore-producing plants (divisions Psilophyta, Lycophta, Sphenophyta, Pterophyta); nonflowering, seed-producing plants (divisions Cycadophyta, Ginkgophyta, Coniferophyta, Coniferophyta); and flowering, seed-producing plants (division Anthophyta).

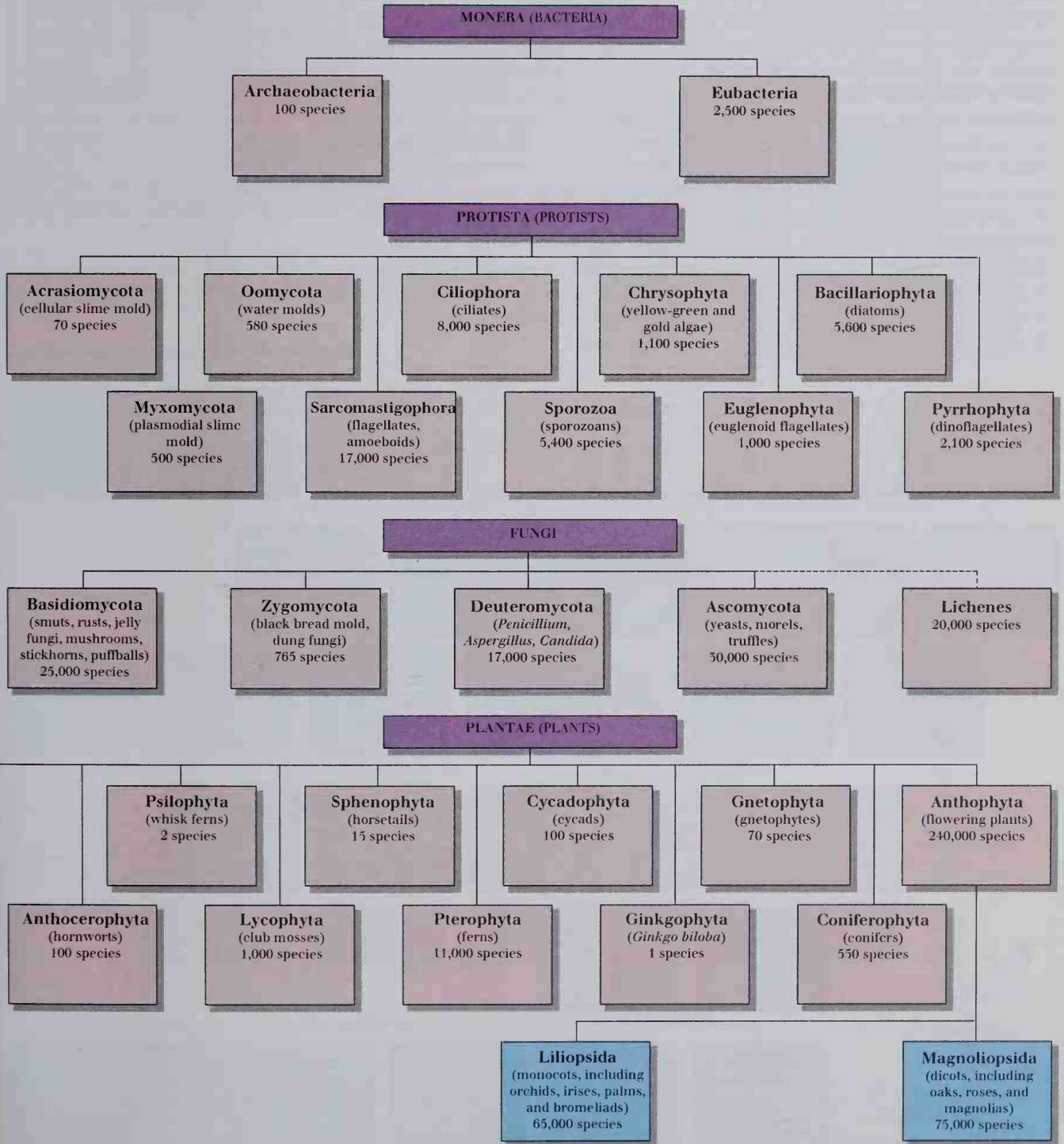

Classification 2

CLASSIFICATION ENABLES BIOLOGISTS to make sense of the bewildering array of living organisms. It identifies and names species by placing them into groups with other species that have similar characteristics. The science of classification is called taxonomy. Taxonomists – biologists that practice taxonomy – name species and trace their phylogeny – the way in which species are linked through **evolution**. They do this by looking for key **anatomical, physiological, behavioral, or molecular** characteristics. If different species share similarities, taxonomists may suggest that they are related through descent from a common ancestor – an extinct organism from which they have inherited their shared characteristics. Such characteristics may be ancient ancestral ones, such as the backbone in vertebrates, or more recently derived characteristics, such as modified forelimbs in bats. There are two major evolutionary classification systems in use today. Traditional systematics, used here for the animal kingdom and on pp. 130-131, groups organisms by using as many characteristics, both ancestral and derived, as possible. Cladistics groups species on the basis of shared derived characteristics alone.

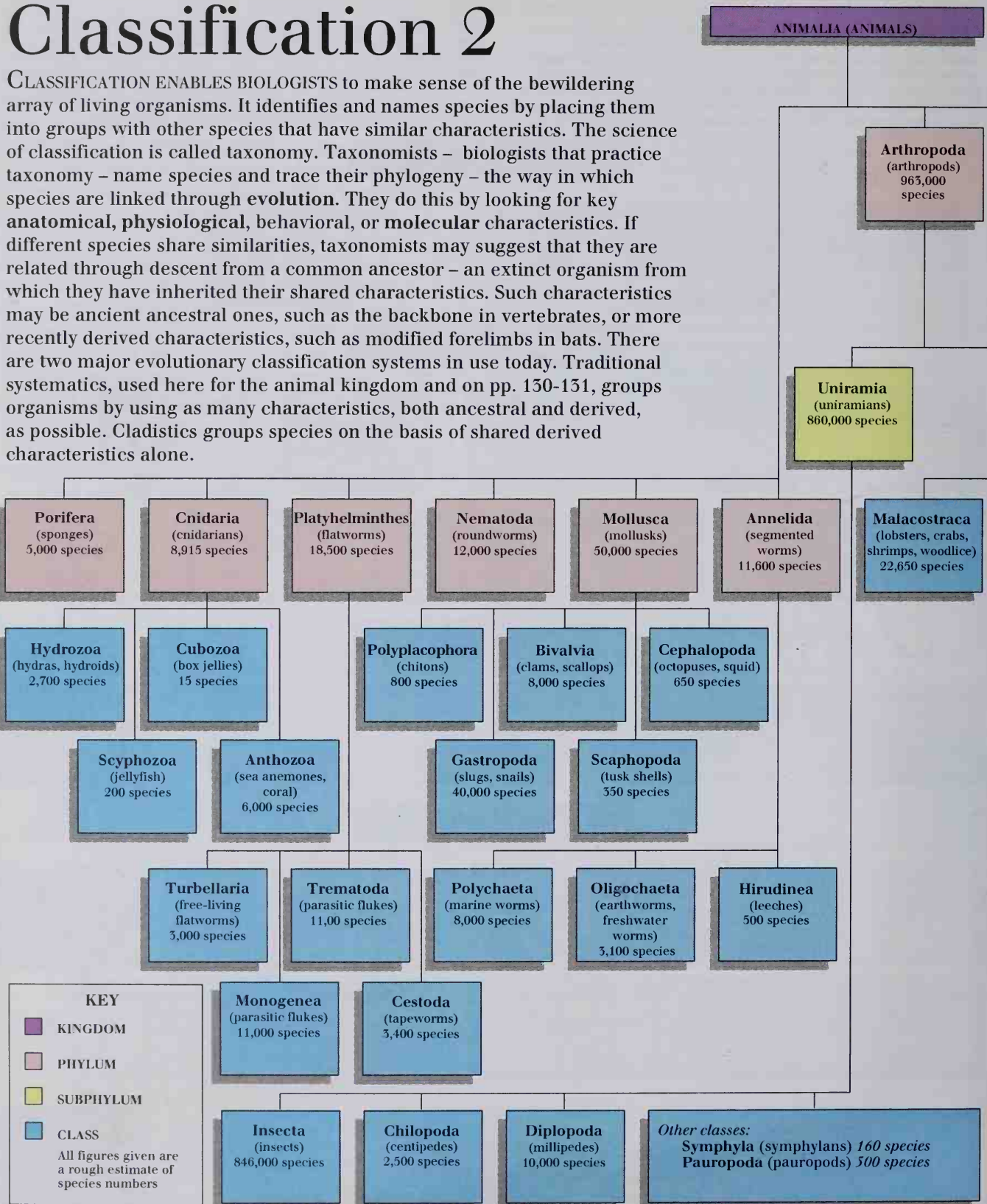

CLASSIFYING ANIMALS

The animal kingdom is one of five kingdoms into which living things are divided. It consists of over 30 phyla, some of which are shown below, with their major classes. The phyla Arthropoda (arthropods) and Chordata (chordates) are divided into subphyla, a category of

classification between phylum and class. The animal kingdom is traditionally split into invertebrates – animals without backbones, which account for most of the species – and vertebrates, animals with backbones found in the subphylum Vertebrata.

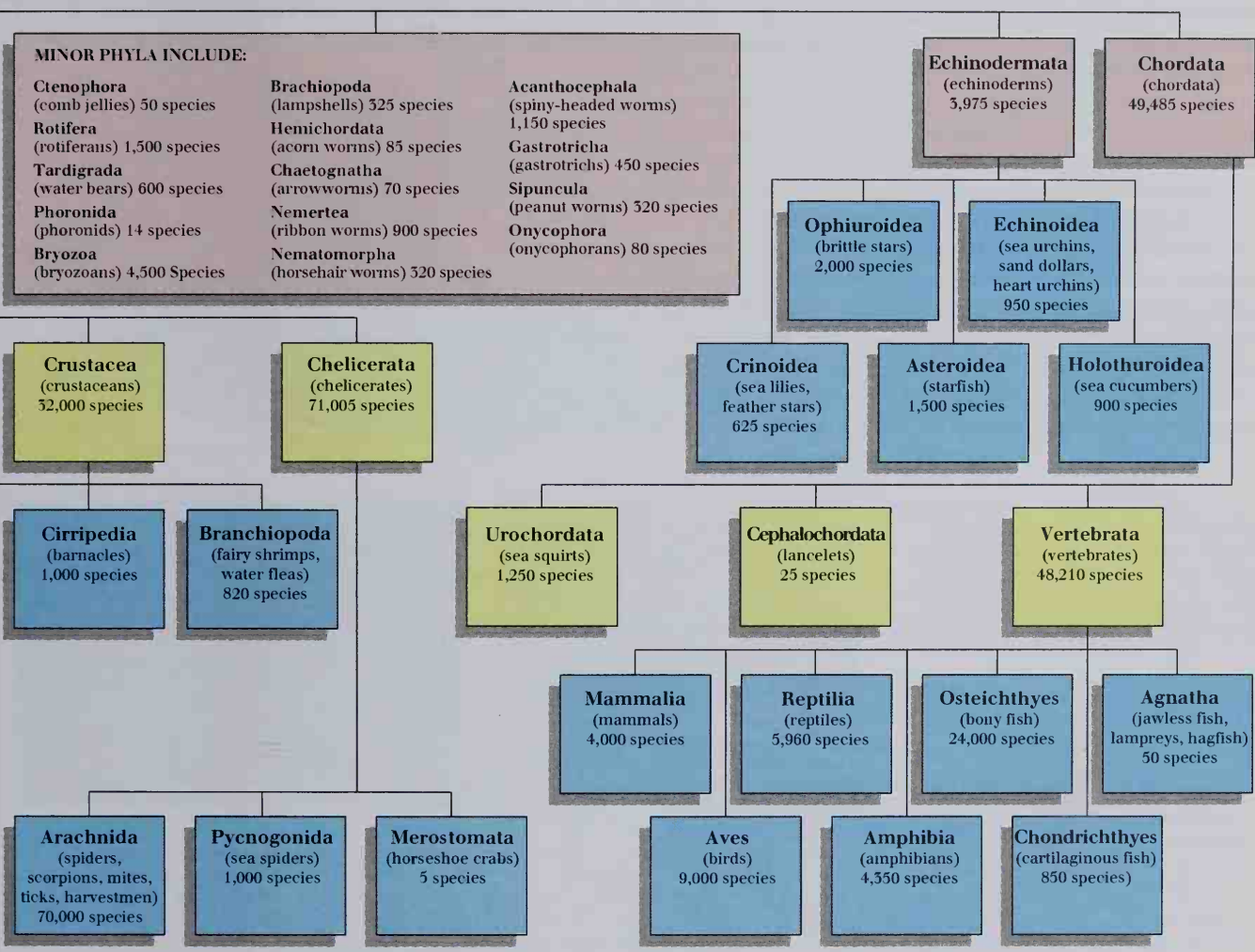

CLADISTICS

Cladistics is another method of classification. Species that share unique, derived characteristics are placed in a group called a clade. All species in a clade are descended from a single, common ancestor. Birds, for example, form a clade because they are descended from a common ancestor that evolved feathers. Clades are arranged into

a branching diagram called a cladogram, which shows those clades that are more closely related to each other. In traditional classification, turtles, lizards and snakes, and crocodiles are grouped together as reptiles (class reptilia), this is known as a grade. Although similar to clades, species in a grade evolve from more than one ancestor.

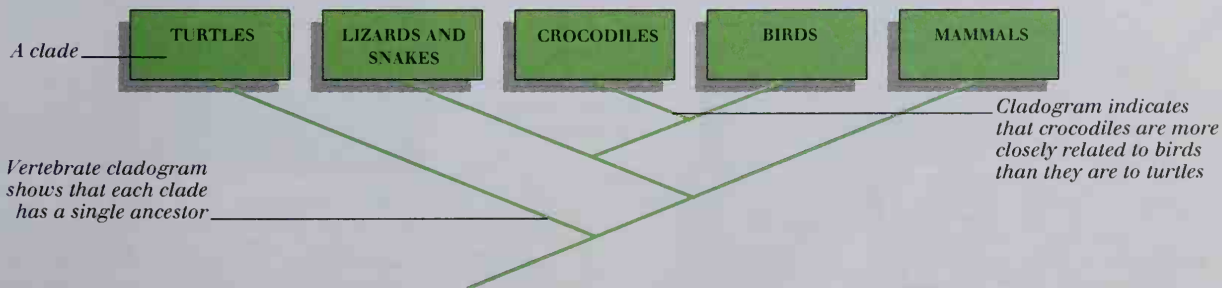

Microorganisms

LIVING THINGS THAT ARE TOO SMALL to be seen without a microscope are called microorganisms. This diverse collection of **unicellular** organisms includes bacteria, protists, and some fungi (see pp. 136-137). Bacteria (kingdom Monera or Prokaryota) are prokaryotic organisms – their cells lack a **nucleus** or any membrane-bound **organelles**. They are the most abundant and widespread organisms on Earth and include saprobes, which feed on dead material, and parasites, which feed on living organisms. Protists (kingdom Protista or Protoctista) include a wide variety of unicellular, eukaryotic organisms – their cells have a nucleus and contain membrane-bound organelles. Animal-like protists, or protozoans, are **heterotrophic** and include amoeba, ciliates, and flagellates; plantlike protists, or algae, are **autotrophic**. A third protist group includes slime and water molds. Viruses are generally included with other microorganisms but they are nonliving and must invade a living **host cell** in order to reproduce (see pp. 258-259).

BACTERIA

STRUCTURE OF A BACTERIUM

A bacterial cell is bounded by a plasma membrane and a tough cell wall. In some cases, the cell wall may be covered by a protective, gelatinous capsule. It may also have long flagella that enable it to swim, and pili that are used to attach it to other cells or food. Inside the cell, there are no

membrane-bound structures. Instead of a nucleus, a circular molecule of DNA is found in a region called the nucleoid. Bacteria may be identified according to their shape: coccus (round); spiral (coiled); and bacillus (rod-shaped) (shown here).

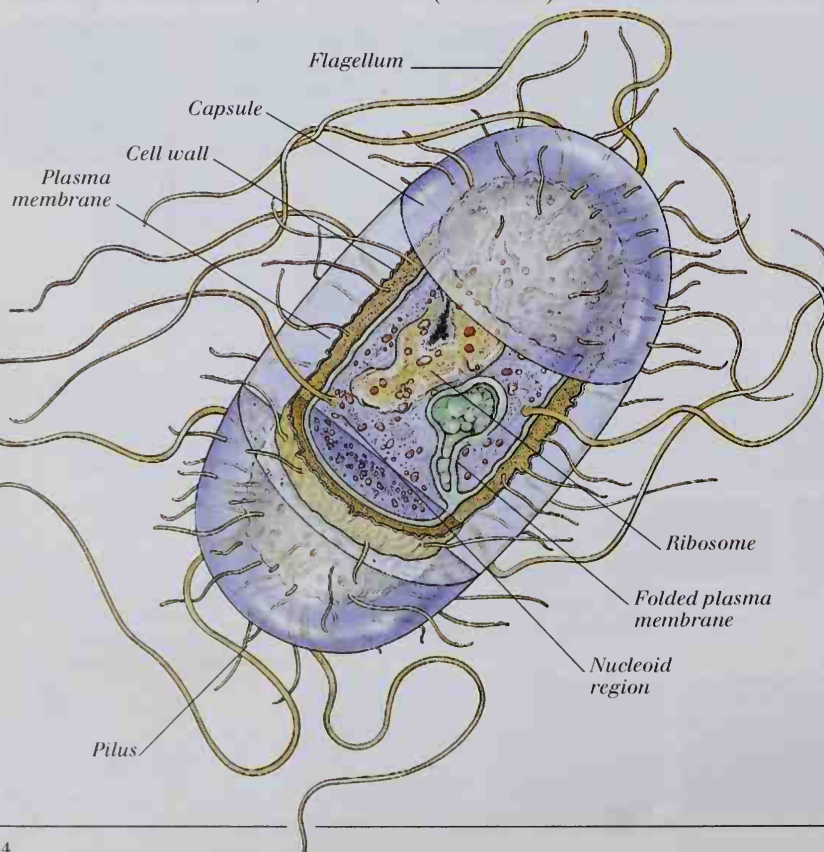

STRUCTURE OF A VIRUS

A virus consists of a core of nucleic acid (either DNA or RNA) and an outer protein coat, or capsid. The length of nucleic acid forms the virus's genetic material and can be replicated only inside a host cell (see pp. 258-259). Surface proteins, called spikes, stud the outer capsid and are involved in attaching the virus to a host cell.

Spikes
(surface
proteins)

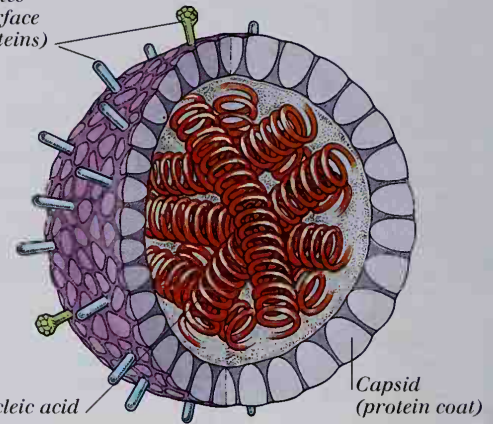

CYANOBACTERIA

Formerly known as blue-green algae, cyanobacteria are bacteria that can produce their own food by photosynthesis. Most cyanobacteria are found in water, and many exist as filaments of linked bacterial cells. Cyanobacteria also play an important role in nitrogen fixation (see pp. 172-173).

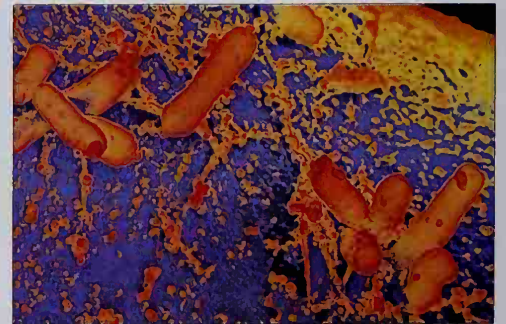

SOIL BACTERIA

Bacteria are found in vast numbers in the soil, and play a vital role as decomposers, helping to break down dead plant and animal material. This process of decomposition releases and recycles vital nutrients, including nitrogen and carbon, needed for plant growth.

PROTISTS

AMOEBIA

Amoeba are protozoans that have a simple structure and no fixed shape. They move by producing temporary extensions called pseudopodia that enable them to "flow" in a particular direction. During feeding, pseudopodia surround and engulf food, such as bacteria, which is taken into the amoeba and digested in a food vacuole. Freshwater amoebas also have a contractile vacuole, which is used for pumping out excess absorbed water.

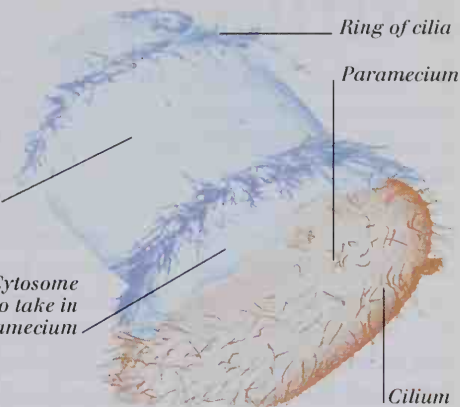
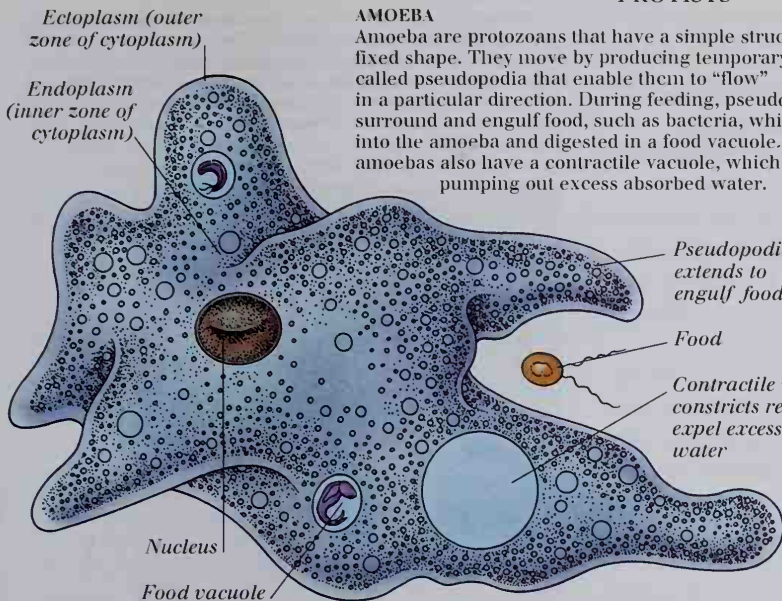

CILIATES

A Paramecium is a slipper-shaped, freshwater microorganism covered by thousands of tiny, hairlike structures called cilia, common to all ciliates. The cilia beat rhythmically, pushing the paramecium through the water as it feeds on bacteria. The barrel-shaped didinium, seen here eating a paramecium, is propelled by two rings of cilia.

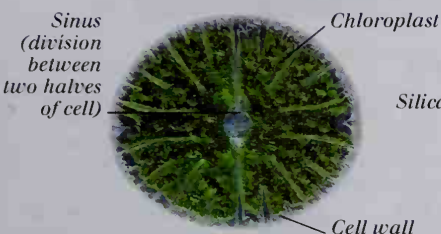

DIATOMS

These marine and freshwater algae form an important part of the phytoplankton. Diatoms have a patterned shell, made of silica, consisting of two halves that fit together like a box and its lid.

GREEN ALGAE

The freshwater desmid (shown here) belongs to the largest division of algae called Chlorophyta. These green algae make their own food by photosynthesis. As well as unicellular species, the division also includes the green seaweeds (see pp. 158-159).

SLIME MOLD REPRODUCTION

Slime molds are protists that resemble amoebae. When food is plentiful, slime mold amoeba live an independent existence, feeding on bacteria and yeasts. When food is in short supply, they secrete a chemical that attracts other amoeba to form a cell mass called a slug. The slug migrates towards the light, eventually comes to rest, and extends upward to form a fruiting body. This releases spores, which disperse and germinate to form new amoeba.

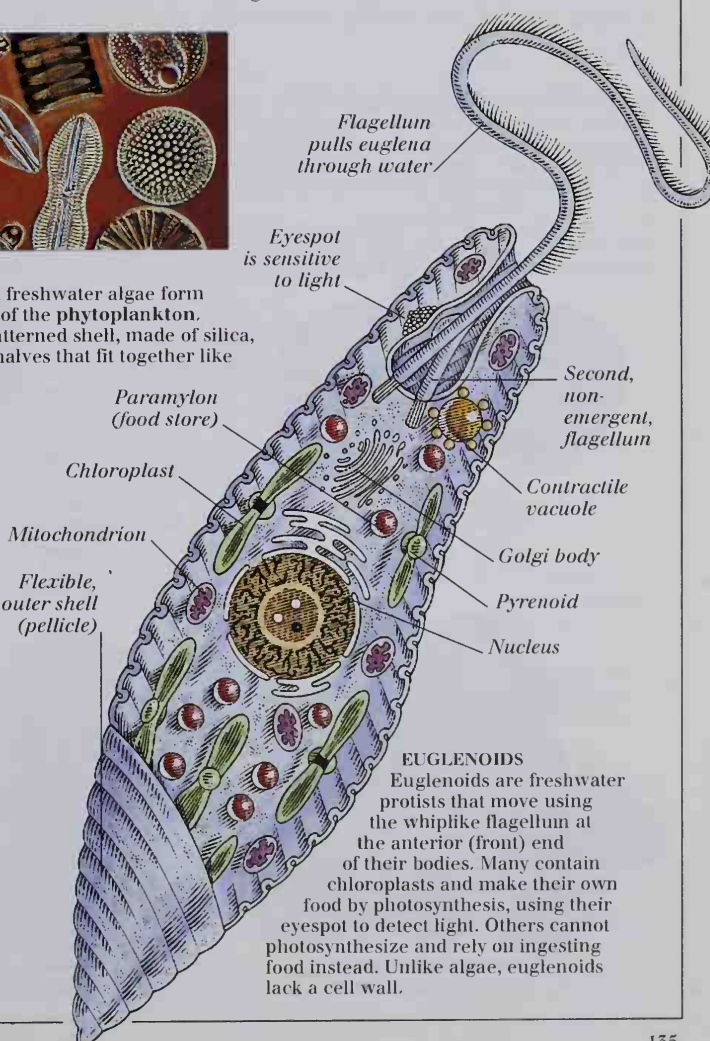
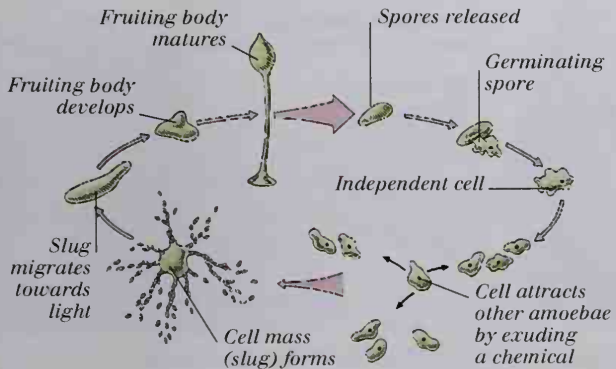

EUGLENOIDS

Euglenoids are freshwater protists that move using the whiplike flagellum at the anterior (front) end of their bodies. Many contain chloroplasts and make their own food by photosynthesis, using their eyespot to detect light. Others cannot photosynthesize and rely on ingesting food instead. Unlike algae, euglenoids lack a cell wall.

Fungi

FUNGI ARE A GROUP of eukaryotic, nonmotile, land-living organisms that includes bread molds, yeasts, mildews, mushrooms, puffballs, and smuts. Most fungi are multicellular and have cell walls that contain chitin. They consist of microscopic, threadlike filaments called hyphae, which branch profusely to form masses called mycelia. Fungi are heterotrophic and absorb nutrients at or near the growing tip of hyphae as they spread through food. Most fungi are saprobes, which means that they feed on dead and decaying organisms. Saprobiic soil fungi, for example, recycle nutrients from dead animal and plant material. Some fungi, such as the candida fungus (see pp. 258-259) are parasites, feeding on living organisms. Others form mutually beneficial symbiotic relationships with other organisms – such as mycorrhizae and lichens. Fungi reproduce by releasing spores from fruiting bodies. Spore-producing structures within fruiting bodies include gills, pores, and spines, depending on the species. The spores may be dispersed actively into air currents, or passively by rain or animals.

YEAST CELLS

Yeasts are microscopic, unicellular fungi. They reproduce asexually by budding a “daughter” cell from the “parental” yeast cell (shown below). This then becomes detached and follows an independent existence. Some yeast species respire anaerobically to convert glucose into ethanol (alcohol) and carbon dioxide. This process is called fermentation. It is exploited by brewers to produce alcoholic drinks, and by bakers, who use carbon dioxide to make bread rise.

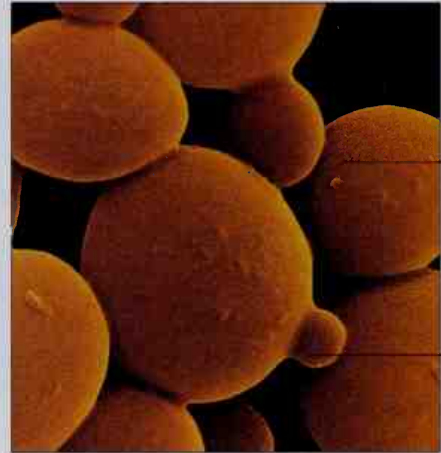

Yeast cell

New cell budding from “parental” cell

EXAMPLES OF FUNGAL FRUITING BODY SHAPES

Fungal fruiting body shapes exhibit a great variety of forms. They all support the hymenium (spore-producing tissue) and are specifically designed to aid spore dispersal. The hymenium may be exposed, as in the fluted bird’s nest and common stinkhorn fungi, or concealed, as in the summer truffle and common puffball fungi. Most fungi, such

as the gilled mushroom opposite, actively release their spores into the air to be dispersed by the wind. Other fungi, such as the fluted bird’s nest, rely on passive dispersal of their spores by splashing raindrops or passing animals. A few fungi, such as the stinkhorn, use scent to attract insects to disperse their spores.

Fruiting body forms underground

Spores are dispersed passively by digging animals or when fruiting body decays



Internal hymenium

BALL-SHAPED:
SUMMER TRUFFLE

Foul-smelling, sticky spore mass is dispersed by flies and beetles

Outer layer dries out and becomes thin and papery

Spores are puffed out through central pore by passing animals or raindrops

Spores inside dry out and become dustlike

Stem holds hymenium above the soil



Spores are produced inside the fruiting body

PESTLE-SHAPED:
COMMON PUFFBALL

Nest-shaped fruiting body

“Egg” is catapulted out by raindrops and spores are released when it decays

Hymenium forms in egg-shaped structure and bursts out

Spores develop inside “egg”



NEST-SHAPED:
FLUTED BIRD’S NEST

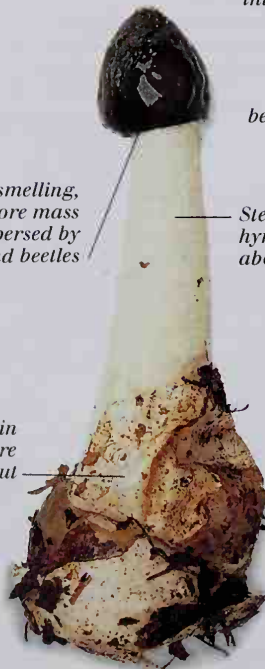

PHALLUS-SHAPED:
COMMON STINKHORN

Sporangium (from which spores are released)

Sporangiophore (stalk) grows from mycelium and supports sporangium

Fruiting bodies resemble a mass of hair

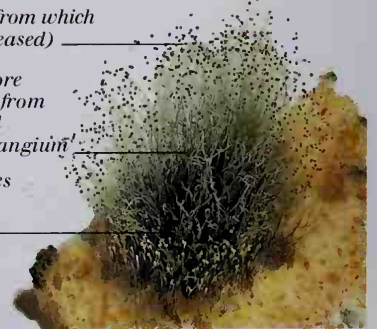

BREAD MOLD

FEATURES OF A GILLED MUSHROOM

Mushrooms are the fruiting bodies of certain fungi belonging to division Basidiomycota. They arise from underground mycelia and consist of a compact mass of hyphae. Gilled mushrooms consist of a cap, in which spores are produced,

and a stem, which lifts the cap above the ground. On the underside of the cap are vertical strips of tissue called gills, which contain spore-producing tissue. When spores are mature, they are caught by air currents as they emerge from the gills.

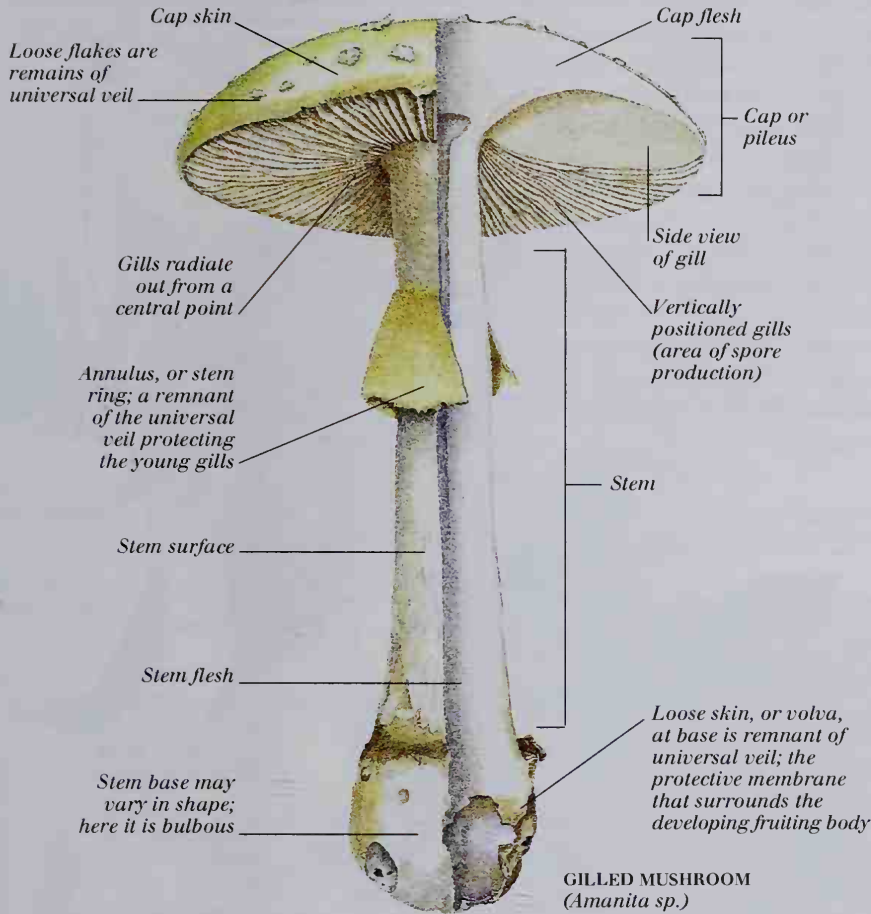

LIFE CYCLE OF A MUSHROOM

Spores germinate when they land in a suitable location. They develop into hyphae, which branch to form a primary mycelium. Adjacent mycelia fuse to form secondary mycelia. Parts of this mass give rise to spore-producing fruiting bodies (mushrooms). Mycelia differentiate within the immature mushroom to form the cap, gills, stem, and other parts. The universal veil ruptures as the stem and cap emerge. When the mushroom matures, it releases its spores.

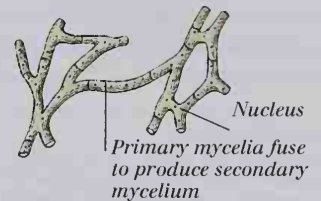
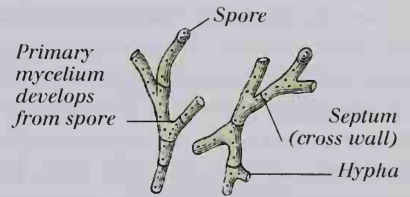

SPORES GERMINATE AND PRODUCE MYCELIUM

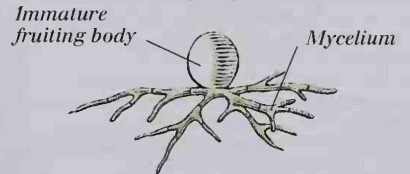

MYCELIUM FORMS FRUITING BODY

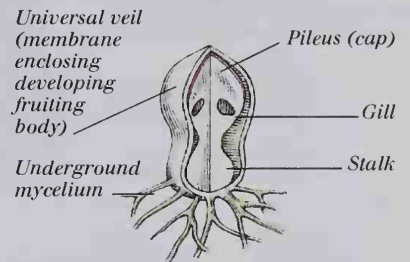

FRUITING BODY GROWS ABOVE GROUND

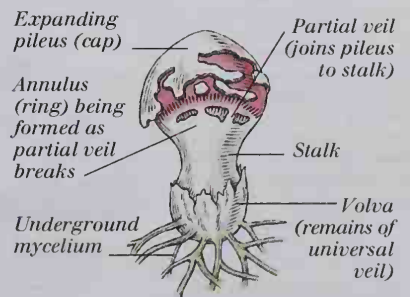

UNIVERSAL VEIL BREAKS

LICHENS

Lichens are the result of a symbiotic (mutually beneficial) relationship between fungi and either green algae or cyanobacteria (see pp. 134-135). Fungal hyphae protect algae from environmental

extremes and pass on essential minerals. Algae produce food by photosynthesis, which is shared with the fungus. This close relationship enables lichens to grow on bare surfaces and in extremely hostile habitats.

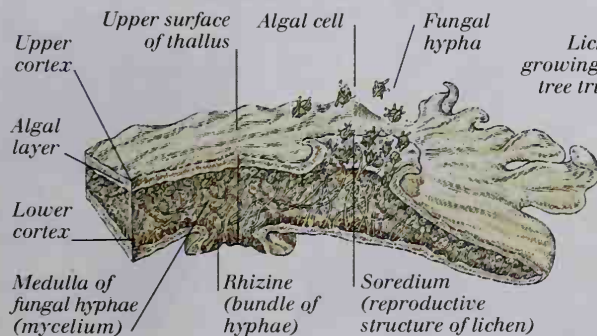

SECTION THROUGH FOLIOSE LICHEN



FOLIOSE LICHEN (Hypogymnia physodes)

Nonflowering plants 1

NONFLOWERING PLANTS REPRODUCE without producing flowers. The simplest of these reproduce by releasing **spores**; the more advanced produce **seeds** (see pp. 140-141). Mosses (division Bryophyta) and liverworts (division Hepatophyta) are the simplest spore-releasing plants. They are found in moist habitats; lack true leaves, stems, and roots; and have no vascular system. The other spore-releasers, horsetails (division Sphenophyta) and ferns (division Pterophyta), have vascular systems. The life cycle of spore-releasing plants involves two generations existing alternately. During the gametophyte generation, gametes (sex cells) are produced, which fuse to produce a **zygote**. This gives rise to the sporophyte generation, which produces spores in a sporangium. When released, these spores germinate and give rise to another gametophyte generation. In mosses and liverworts, the gametophyte is the dominant generation; in horsetails and ferns the sporophyte is the dominant generation. Although seaweeds are included as nonflowering plants here, some biologists class them as protists (see pp. 150-151).

LIVERWORTS

Liverworts are simple green plants, found in damp, shaded locations, and sometimes in water. There are two types, both of which are prostrate (grow along the ground). Thalloid liverworts are flattened and ribbonlike; leafy liverworts have scalelike "leaves" arranged in rows. Both types of liverworts can reproduce sexually and asexually. Following sexual reproduction, spore-producing sporangium develops on the underside of the archegoniophore. Asexual reproduction occurs when clusters of cells, called gemmae, are splashed out of gemma cups by raindrops. They then grow into new plants.

THALLOID LIVERWORT
(*Marchantia polymorpha*)

Gemma cup
containing gemmae

Flattened thallus (plant
body) of gametophyte



MOSSES

These small, simple plants often grow together in clumps usually under damp conditions. They have upright "stems" and spirally arranged scalelike "leaves." In most mosses, the capsule, or sporangium, is at the end of a long seta, or stalk. When ripe, this opens to release spores.

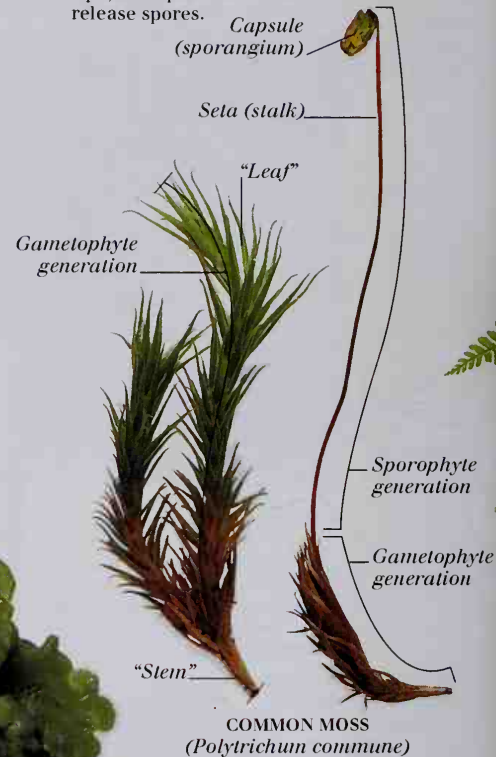

COMMON MOSS
(*Polytrichum commune*)

Supportive
midrib

Stalked archegoniophore
(female reproductive
structure)

SEAWEEDS

There are three types of seaweeds: brown, green, and red. They are all multicellular marine algae and are usually found in the intertidal zone of the shore or just below the low tide mark. Their color depends on the photosynthetic pigments they use to harness the Sun's energy. Typically, seaweeds have a flattened body, or thallus, that is attached to rocks or the seabed by a holdfast. Most reproduce sexually by releasing gametes into the sea. Fertilized eggs settle on rocks and grow into new seaweeds.

Fertile tip releases
gametes into
the sea

Supportive
midrib

Crinkled
margin

Unbranched, spirally
twisted frond

Lamina (blade)



BROWN SEAWEED
(*Fucus spiralis*)

GREEN SEAWEED
(*Enteromorpha linza*)

RED SEAWEED
(*Dilsea carnosa*)

FERNS

The sporophyte generation in ferns is a green plant with leaves, stems, and adventitious roots that grow from an underground stem. Water and nutrients from the soil are transported around the plant by its internal vascular system. The large fronds, or leaves, are divided into many pinnae, or leaflets, each of which may be divided further into smaller pinnules. Sporangia develop on the undersides of pinnules in groups called sori and release spores into the air.



LIFE CYCLE OF A FERN

Spores released from sporangia germinate in damp conditions to form a simple, heart-shaped prothallus (gametophyte). This bears antheridia and archegonia, the male and female sex organs. Antheridia release mobile gametes (sex cells) called antherozoids. These swim in a film of water to an archegonium and fertilize the oosphere (egg). A new fern plant (sporophyte) develops from the fertilized oosphere.

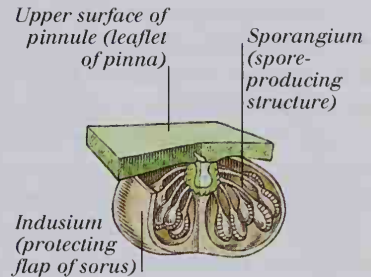

SECTION THROUGH PINNULE



RELEASE OF SPORES

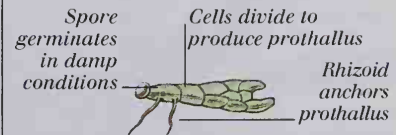

GERMINATION OF SPORE

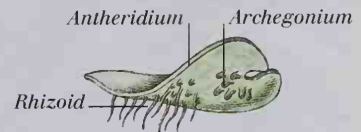

GAMETOPHYTE PRODUCES GAMETES

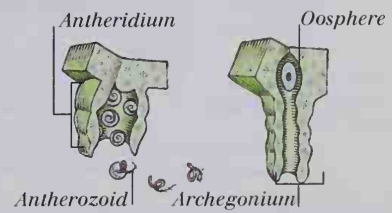

FERTILIZATION

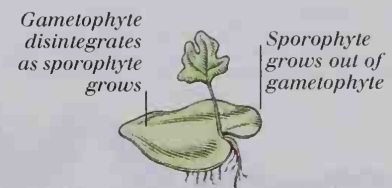

NEW SPOROPHYTE PLANT GROWS

HORSETAILS

Horsetails have upright, hollow, jointed stems with rings of small leaves. They reproduce in two ways: by releasing spores or through creeping rhizomes (underground stems) from which new shoots arise. There are two types of shoots: sterile shoots, which have whorls (rings) of narrow, green, photosynthetic branches; and fertile shoots, which are not green (contain little or no chlorophyll) and have no branches. Each fertile shoot carries a single strobilus (a mass of sporangia) where spores are produced.

Nonflowering plants 2

THE MORE ADVANCED PLANTS, of which there are five divisions, reproduce by means of seeds. Four divisions of seed-producing plants are nonflowering – collectively known as the gymnosperms (“naked seeds”) because their seeds develop unprotected by a fruit (the fifth division is the flowering plants). Most gymnosperms are evergreen trees that have male and female reproductive structures in the form of cones. Pollen is usually blown by the wind from the male cone to the female cone, where fertilization takes place. The “naked” seeds then develop on the surface of scales in a female cone. Most gymnosperms are shrubs or trees, and many are xerophytes (adapted to living in dry conditions). The four divisions of gymnosperms are: the ginkgo, a deciduous species; cycads, found mainly in the tropics; gnetophytes, mostly trees and shrubs; and conifers, which include pines.

EXAMPLES OF GYMNASPERMS

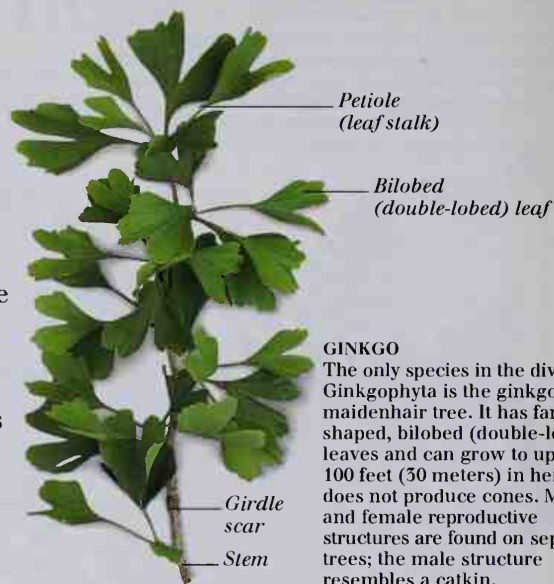

GINKGO
(*Ginkgo biloba*)

GINKGO

The only species in the division Ginkgophyta is the ginkgo, or maidenhair tree. It has fan-shaped, bilobed (double-lobed) leaves and can grow to up to 100 feet (30 meters) in height. It does not produce cones. Male and female reproductive structures are found on separate trees; the male structure resembles a catkin, and the female consists of paired ovules. After fertilization, the female tree produces seeds protected by a fleshy covering.



SAGO PALM
(*Cycas revoluta*)

CYCAD

Shaped like a small palm tree, cycads have a distinct “trunk” covered with woody scales, and a crown of long, divided leaves. Large cones grow in the center of the crown, with male and female cones appearing on different plants.



YEW
(*Taxus baccata*)

CONIFER

Conifers include pines, cypresses, redwoods, larches, cedars, and yews. Most of them are tall trees with tough, leathery, evergreen leaves that range in shape from thin needles to flat scales. Seeds typically develop within woody female cones, which are usually larger than male cones, and often grow separately on the same tree. Yews lack true cones.

GNETOPHYTE

A highly diverse gymnosperm group, the gnetophytes are mostly trees and shrubs. The desert plant welwitschia is an unusual, horizontally growing gnetophyte with two long, straplike leaves and a central, short trunk.

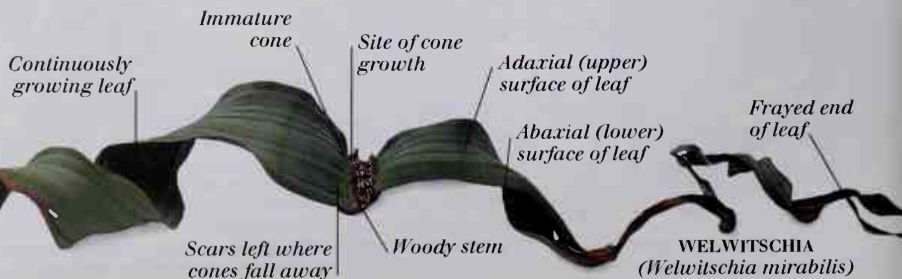

WELWITSCHIA
(*Welwitschia mirabilis*)

FEATURES OF BISHOP PINE (*Pinus muricata*)

MICROGRAPH OF FOLIAGE LEAF (NEEDLE)

The surface of a pine needle is pitted with rows of stomata (pores). The stomata are sunken in the waterproof cuticle (outer covering) of the needle. This adaptation reduces water loss from the leaf and enables the tree to withstand the drying effect of the wind.



Upper surface
Margin
Stoma (pores through which gases enter and leave)

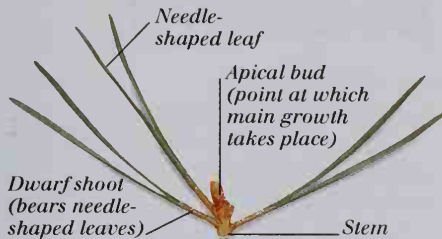

Needle-shaped leaf
Apical bud (point at which main growth takes place)
Dwarf shoot (bears needle-shaped leaves)
Stem

TERMINAL ZONE OF BRANCH

The apical bud at the tip of a branch is an active growing point from which the next year's growth of the branch will occur. Behind it are dwarf shoots that show limited growth and bear the needle-shaped leaves typical of all pines.

Second-year female cone



Ovuliferous scale (ovule and seed-bearing structure)

Group of male cones

Dwarf shoot

Needle-shaped leaf

Scar of dwarf shoot

BRANCH OF BISHOP PINE
Pines are conifers that have needles bunched on dwarf shoots that grow spirally from the stem. When dwarf shoots are shed, they leave a scar that gives the stem its rough texture. Male and female cones are borne on different branches; male cones in clusters at the tip of a branch, and female cones singly or in pairs.

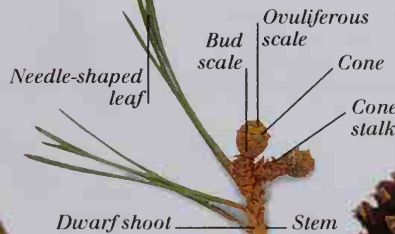

FEMALE CONE (FIRST YEAR)

Woody, ovuliferous scale (open to release seed)



FEMALE CONE (THIRD YEAR)

LIFE CYCLE OF SCOTS PINE (*Pinus sylvestris*)

Pollen grains, which contain male gametes, are released in the spring from male cones and are carried by the wind to immature (first-year) female cones. Pollination occurs when a pollen grain sticks to the micropyle – the opening to the ovule that contains the female gamete (ovum). A pollen tube grows slowly from it and carries the male gamete toward the ovum. The gametes meet, fertilization occurs, and a winged seed develops. The mature (third-year) cone opens up and releases the seed into the wind. When it reaches the soil, it germinates into a pine seedling which grows into a new plant.

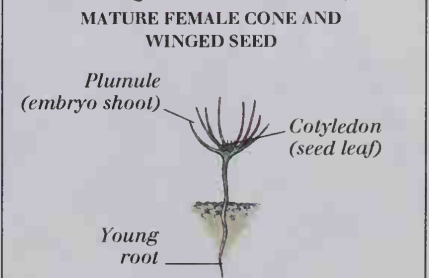
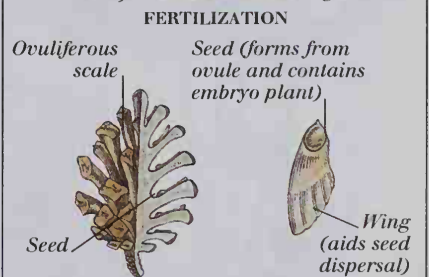
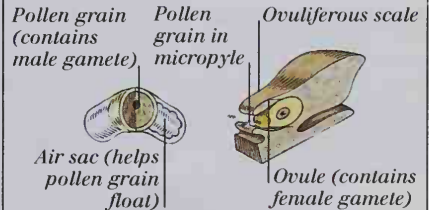
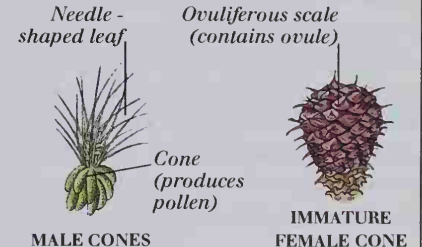

GERMINATION OF PINE SEEDLING

Flowering plants 1

THE LARGEST AND MOST DIVERSE group of plants are the flowering plants (division Anthophyta). These reproduce by releasing seeds, which are produced by reproductive structures called flowers. Flowers consist of sepals and petals, which protect the flower, and male and female reproductive organs (see pp. 146-147); many attract **pollinating** animals. There are two classes of flowering plants: monocotyledonous plants, or monocots (class Liliopsida), which produce seeds with a single **cotyledon**, and dicotyledonous plants, or dicots (class Magnoliopsida), which produce seeds with two cotyledons. Herbaceous flowering plants have green stems and die back at the end of the growing season. Woody flowering plants, which include shrubs and trees, have thick, supportive stems, reinforced with wood; these survive cold winters above ground and may live for many years. Most monocots are herbaceous, while dicots include both herbaceous and woody species.

HERBACEOUS FLOWERING PLANT

The stem of a herbaceous plant, such as this strawberry, is green and nonwoody, dying back at the end of each growing season. If the plant is perennial, the underground parts survive to produce new shoots in the next growing season. Annual plants die completely, having first produced seeds.

ANATOMY OF A WOODY FLOWERING PLANT

Flowering plants have a root system below ground that anchors the plant and takes in water and nutrients from the soil. Above ground level is a stem with leaves and buds that arise at nodes. Leaves are borne on petioles (leaf stalks). Buds may form at the stem apex (apical buds) or between the stem and petiole (lateral buds). Both types of buds may give rise to leaves or flowers. The stem of the tree mallow is typical of most woody flowering plants with, in the mature plant, a woody core surrounded by a layer of protective bark.

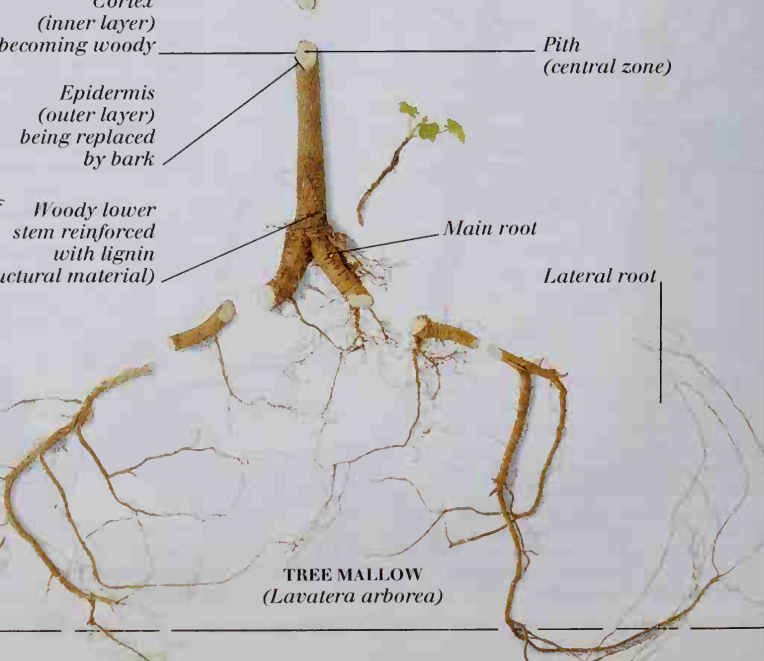
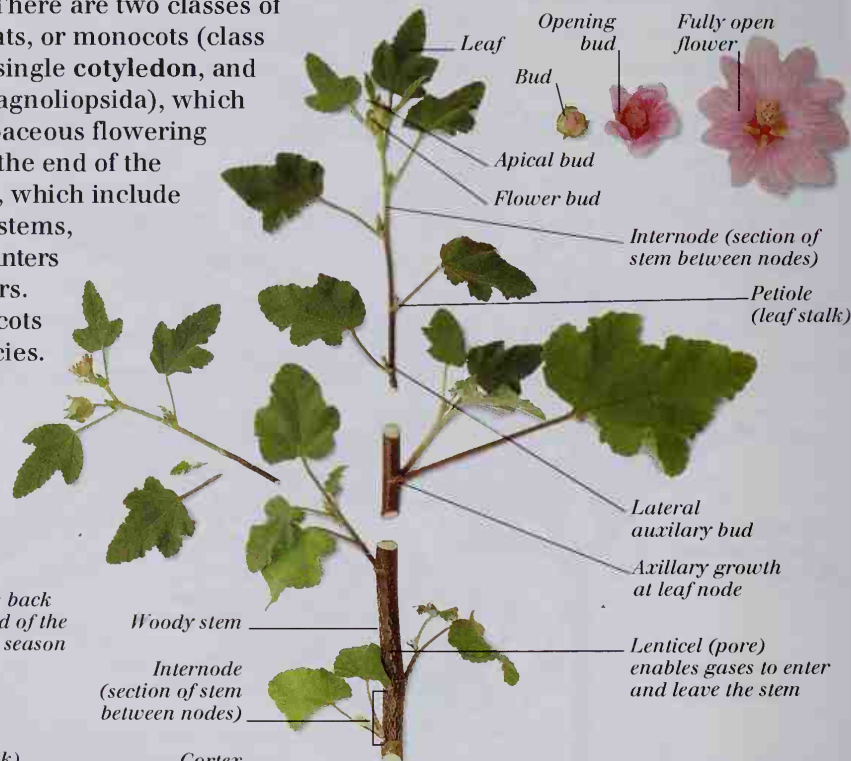

MONOCOTYLEDONOUS AND DICOTYLEDONOUS PLANTS



VEINS OF A MONOCOT LEAF



VEINS OF A DICOT LEAF

MONOCOT AND DICOT LEAF STRUCTURE

Monocot and dicot leaves differ according to the arrangement of their veins. Monocot leaves have parallel veins that run along the long axis of the leaf. Dicot leaves typically have a network of veins that radiate from a central midrib.

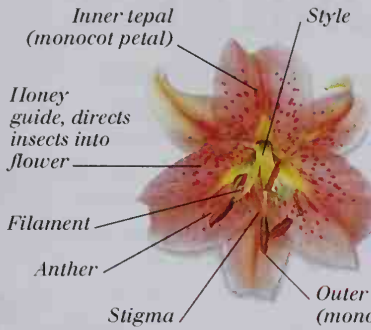

MONOCOT FLOWER

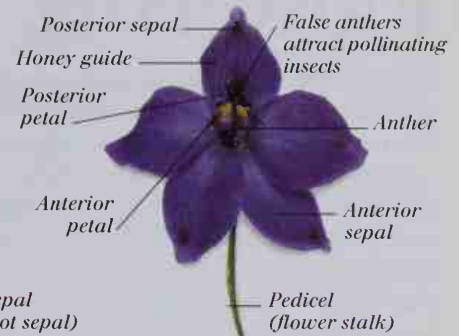

DICOT FLOWER

MONOCOT AND DICOT FLOWER STRUCTURE

Monocot flowers such as the lily (shown above) have flower parts that occur in multiples of three. The sepals and petals are typically large and indistinguishable; individually they are called tepals. Dicot flowers, such as this larkspur (shown above), have flower parts that occur in fours or fives. Most have small, green sepals and prominent, colorful petals. The larkspur, however, has large, colorful sepals and smaller petals.

GENERAL FLOWER STRUCTURE

FEATURES OF A FLOWER

A flower consists of four whorls (rings) of parts arranged around the receptacle (tip of the flower stalk). The outermost whorl, the calyx, consists of sepals – large and colorful in monocots, usually small and green in dicots. The corolla is the whorl of petals; these are prominent and colorful in animal-pollinated flowers. The androecium (male reproductive structure) is a whorl of stamens, each consisting of a filament and an anther. The gynoecium (female reproductive structure) has one or more carpels. Each carpel consists of a stigma, style, and an ovary.

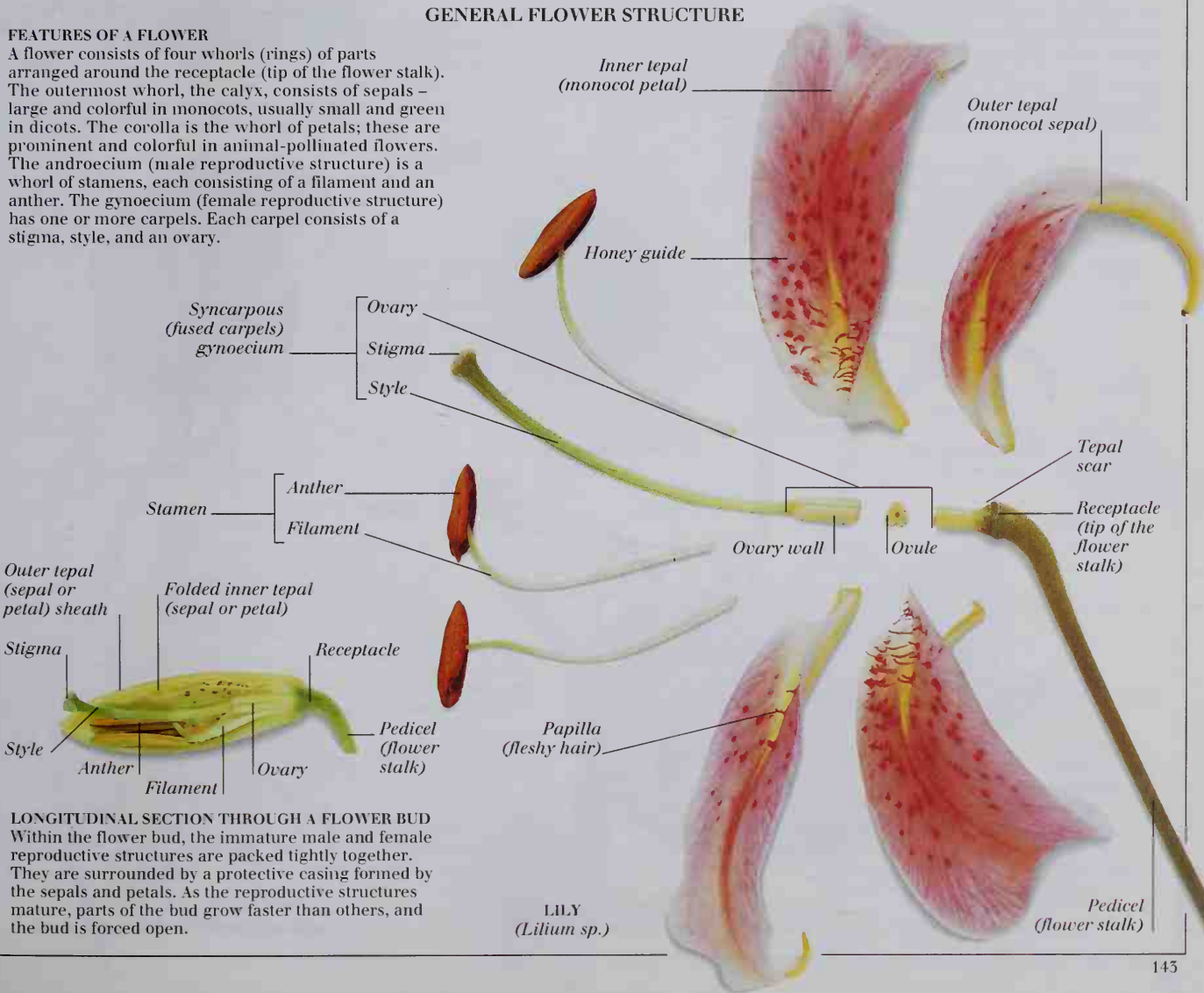

LONGITUDINAL SECTION THROUGH A FLOWER BUD
 Within the flower bud, the immature male and female reproductive structures are packed tightly together. They are surrounded by a protective casing formed by the sepals and petals. As the reproductive structures mature, parts of the bud grow faster than others, and the bud is forced open.

LILY (*Lilium sp.*)

Pedicel (flower stalk)

Flowering plants 2

FLOWERING PLANTS FORM a diverse group that ranges in size and form from delicate pondweeds to tall, ancient oak trees. They all consist of the same basic parts, but these show great variety. Flowers vary greatly in shape and size and have evolved to maximize the chances of **pollination and fertilization**. Many have large petals to attract pollinating animals; wind-pollinated flowers are small and less colorful (see pp. 146-147). Some plants have solitary flowers; others have groups of flowers. Leaves are similarly varied. All **monocots** and some **dicots** have simple leaves; other dicots have compound leaves consisting of smaller leaflets. Flowering plants have successfully exploited most of the world's **habitats**, including deserts, marshland, freshwater, and the tropics. Some are adapted to surviving in conditions that flowering plants would not normally tolerate.

EXAMPLES OF FLOWER TYPE

Some flowering plants, such as the glory lily, have a single flower on a pedicel (flower stalk). Others produce inflorescences (flower heads), which vary in size, shape, and number of flowers. They can be classified as, for example, spadix, spike, cyme, or umbel, according to the arrangement of flowers. Composite flowers, such as the sunflower, have an inflorescence that consists of many tiny flowers (florets) clustered together.

EXAMPLES OF LEAF TYPE

Leaves are classified according to the form of their lamina, or blade. In simple leaves, such as the iris and sweet chestnut, the lamina is a single unit. In compound leaves, such as the black locust, the lamina is divided into separate leaflets. Leaves can be further classified by the overall shape of the lamina and whether its margin (edge) is smooth or not.

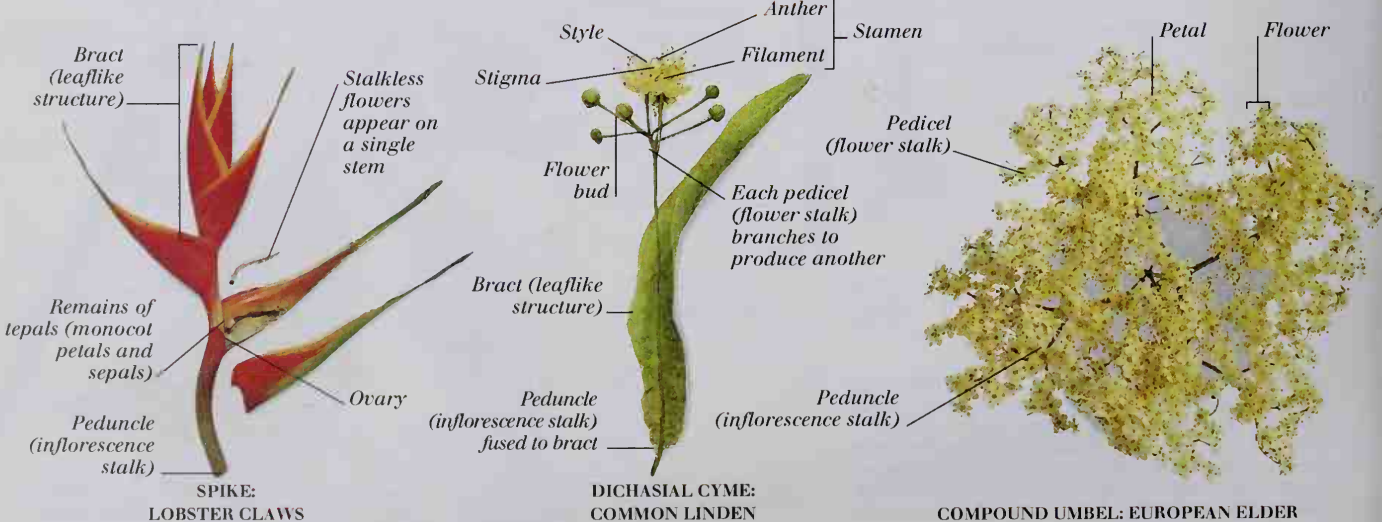
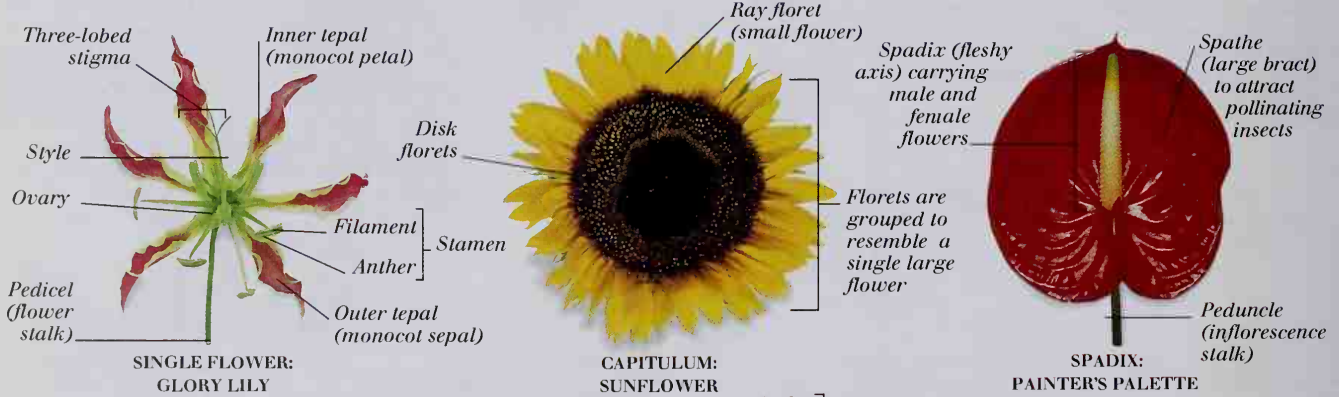

EXAMPLES OF FLOWERING PLANT DIVERSITY



EPIPHYTIC ORCHID
(*Brassavola nodosa*)

EPIPHYTIC PLANTS

Epiphytic plants grow on other plants but do not take nutrients from them. In tropical forests, epiphytic orchids grow on trees in order to reach the light that enters the canopy, but does not penetrate to the forest floor. They obtain water from rainwater or the air and extract nutrients from plant material that collects nearby on tree bark.

Flower

Leaf

Leaf

Node

Stem

Inflated petiole (leaf stalk) provides buoyancy
Isthmus (narrow connecting region)
Orbicular lamina (blade)

Abaxial (lower) surface of lamina (blade)
Adaxial (upper) surface of lamina (blade)

Dense, fibrous root system

Rhizome

Adventitious roots hang in the water

Lateral branch of adventitious root

WETLAND PLANTS

Wetland plants grow partially or completely submerged in areas of fresh water. Most have air spaces inside stems, leaves, or roots to aid buoyancy; the water hyacinth has inflated petioles (leaf stalks). Some are rooted in, and obtain nutrients from, the lake or river bottom; others absorb nutrients directly from the water.

WATER HYACINTH
(*Eichhornia crassipes*)

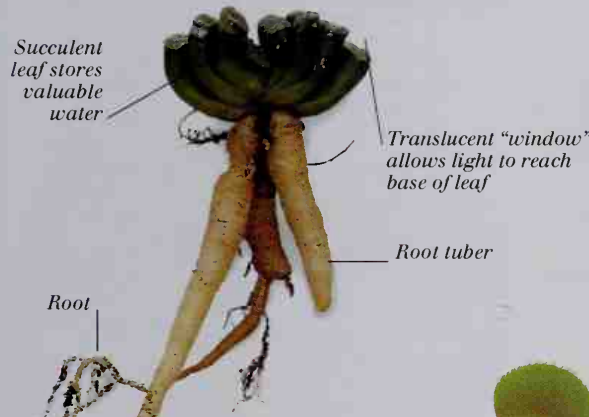

DRYLAND PLANTS

Many dryland plants, or xerophytes, are succulents – plants that can store water in their tissues. Leaf succulents have enlarged, fleshy, water-storing leaves with a waxy coating that reduces water loss through transpiration. Stem succulents, such as cacti, store water in fleshy stems; their leaves are absent or reduced to spines. Root succulents store water in tubers, underground storage organs.

LEAF SUCCULENT
(*Haworthia truncata*)

Midrib (hinge of trap)
Leaf is adapted to form a trap

Summer petiole (leaf stalk)

Phyllode (flattened petiole)

CARNIVOROUS PLANTS

In addition to making food by photosynthesis, carnivorous plants also feed on insects. Most grow in waterlogged soils lacking nitrates and other essential minerals. Insects are trapped, broken down by enzymes, and absorbed to supply these missing nutrients.

Immature trap

Closed trap

Interlocked teeth

Red color of trap attracts insects

Trap (twin-lobed leafblade)

Nectary zone (glands secrete nectar to attract insects)

Digestive zone (glands secrete digestive enzymes to break down insects)

Trigger hair detects insect and causes trap to shut

Spring petiole (Stalk leaf)

VENUS FLYTRAP
(*Dionaea muscipula*)

Flowering-plant reproduction

FLOWERS ARE THE SITES OF SEXUAL REPRODUCTION in flowering plants. In order for them to produce seeds, pollination and fertilization must occur. Pollination involves the transfer of **pollen**, which contains the male **gametes**, from an **anther** to a **stigma**. Most flowers contain both anthers and stigmas, but to ensure **genetic variation**, pollination usually occurs between flowers on different plants. The pollen may be carried between plants by animals, the wind, or water. When the male and female gametes meet, fertilization takes place. This happens within the ovule, which is surrounded by the ovary. The fertilized ovum – female gamete – develops into an **embryo**, which, with its food store and **testa**, forms the seed. When fully developed, seeds are dispersed (sometimes within their fruit) away from the parent plant. Under the right conditions, the seeds germinate and grow into new plants.

REPRODUCTIVE STRUCTURES IN A WIND-POLLINATED PLANT

Because they have no need to attract animal pollinators, wind-pollinated flowers are usually small, inconspicuous, dull-colored, and unscented. They are also commonly unisexual – male and female flowers are found on separate plants or on different parts of the same plant. Anthers in the male flower hang exposed at the end of long filaments and release large numbers of light, smooth pollen grains that are carried by the wind. Stigmas in the female flower are also exposed and poised to intercept any windblown pollen grains that pass near.



MICROGRAPH OF A POLLEN GRAIN

During the journey between the anther and stigma, the male gametes are protected within the thick walls of a pollen grain. The wall consists of an inner intine and a tough, external exine that, when viewed under a scanning electron microscope, is often seen to be elaborately sculptured. These patterns can be used to identify plant species.

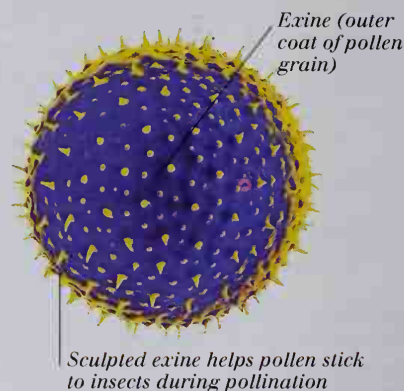

INSECT POLLINATION

Insects, such as bees, are attracted to flowers by their color, smell, and the sugary nectar they often contain. As the bee crawls into the flower, pollen grains are dusted onto it. When the insect visits another flower of the same species, pollen grains are transferred to the sticky stigma.

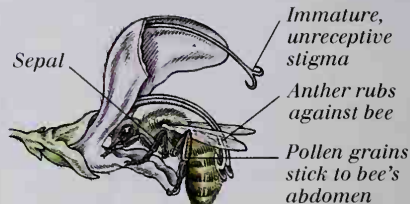

BEE VISITS FIRST FLOWER



BEE FLIES TO SECOND FLOWER

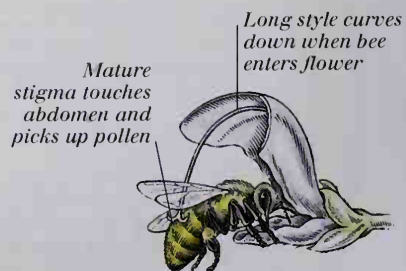

BEE VISITS SECOND FLOWER

DEVELOPMENT OF A SUCCULENT FRUIT: BLACKBERRY (*Rubus fruticosus*)

The blackberry flower attracts insects to pollinate it. Once pollination and fertilization have occurred, the flower parts wither. A seed develops inside each of the carpels, and the ovary wall

surrounding the seeds swells and ripens, forming the pericarp. Together, the seed and pericarp form a fruit. Animals eat the succulent fruit and the seeds pass out, unharmed, in their droppings.

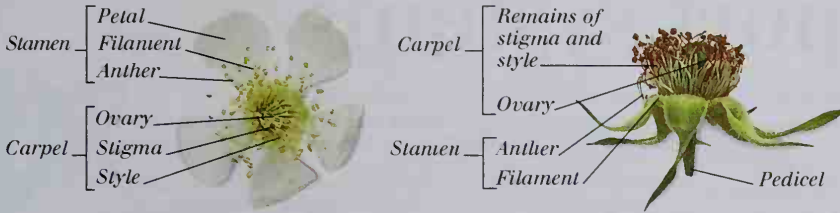

FLOWER ATTRACTS POLLINATORS

OVARIES SWELL, STAMENS WITHER

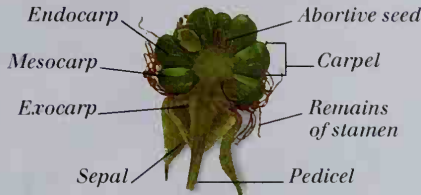

PERICARP FORMS



DRUPELETS RIPEN FULLY

GERMINATION OF A FAVA BEAN SEED (*Vicia faba*)

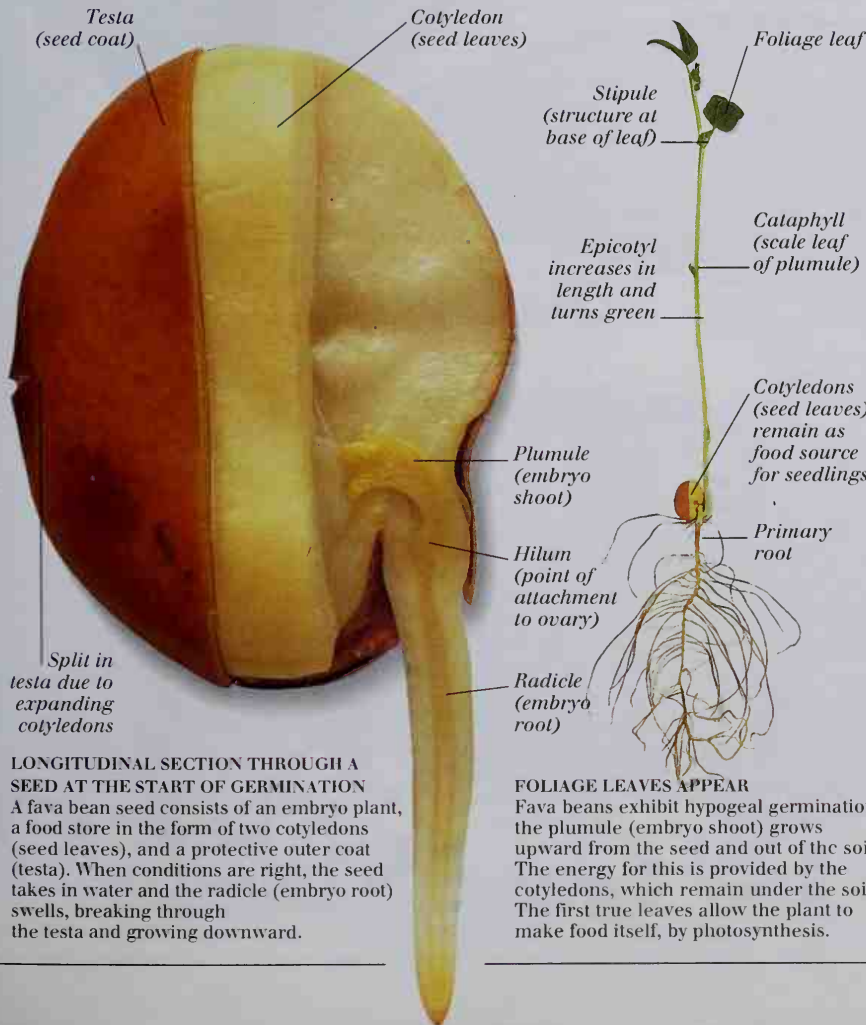

LONGITUDINAL SECTION THROUGH A SEED AT THE START OF GERMINATION
A fava bean seed consists of an embryo plant, a food store in the form of two cotyledons (seed leaves), and a protective outer coat (testa). When conditions are right, the seed takes in water and the radicle (embryo root) swells, breaking through the testa and growing downward.

FOLIAGE LEAVES APPEAR
Fava beans exhibit hypogeal germination – the plumule (embryo shoot) grows upward from the seed and out of the soil. The energy for this is provided by the cotyledons, which remain under the soil. The first true leaves allow the plant to make food itself, by photosynthesis.

THE PROCESS OF FERTILIZATION

When a pollen grain lands on a stigma it produces a pollen tube, which grows through the style and ovary wall and enters the inner part of the ovule. The two male gametes from the pollen grain travel down the pollen tube. One fuses with the ovum to form the embryo. The other fuses with the polar nuclei to form the endosperm – the embryo's food supply.

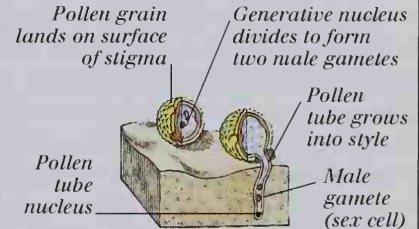

POLLEN GRAIN GERMINATES

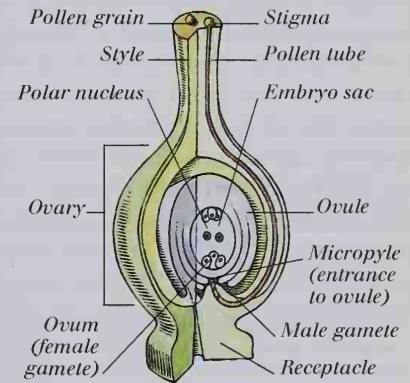

MALE GAMETES TRAVEL TO EMBRYO SAC

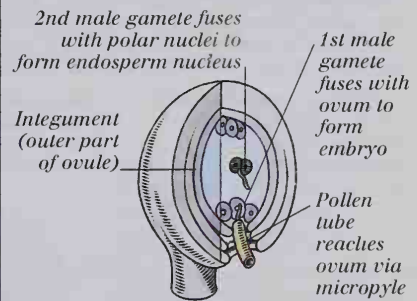

FERTILIZATION OCCURS

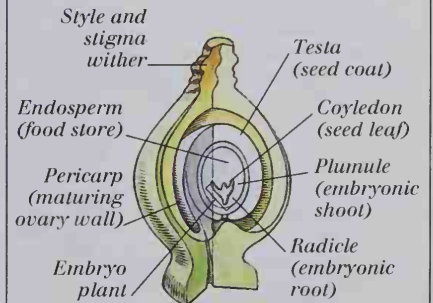

DEVELOPMENT OF EMBRYO

Photosynthesis and plant-transport systems

PLANTS ARE AUTOTROPHIC – they manufacture food themselves, by photosynthesis. This is a process that converts sunlight energy into chemical energy, which is then used to combine carbon dioxide and water to produce complex carbohydrates such as glucose, sucrose, and starch – the plant's main energy store. Photosynthesis takes place inside chloroplasts – organelles that are found only in plant and algal cells (see pp. 122-123). Chloroplasts contain pigments, including chlorophyll, that can absorb and harness sunlight energy. Photosynthesis is of vital importance to living organisms because it “fixes” carbon by removing carbon dioxide from the air to produce carbohydrates. These feed and build plants and are also the primary food source for all heterotrophic organisms. Plant-transport systems carry materials to where they are needed. There are two types of vascular tissue, which consist of tubular cells: xylem carries water and minerals from the roots to other parts of the plant and also helps to support it; phloem carries nutrients from where they are made, such as carbohydrates in the leaves, to where they are required.

STRUCTURE OF A CHLOROPLAST

A chloroplast is a disk-shaped organelle that is surrounded by an inner and outer membrane. Inside the chloroplast, molecules of chlorophyll and other pigments are packed into a system of membranes. These form flattened, saclike structures called thylakoids, which are arranged in stacks called grana that provide a large surface area for trapping sunlight energy during photosynthesis. Grana are surrounded by the stroma, a liquid matrix in which trapped energy is used to manufacture sugars.

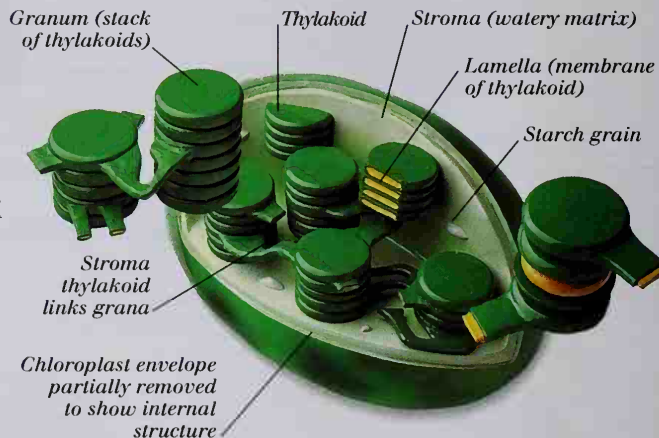

THE PROCESS OF PHOTOSYNTHESIS

Photosynthesis takes place inside the chloroplasts of leaf cells and of other green parts of the plant. The raw materials for photosynthesis are carbon dioxide from the air and water from the soil. There are two stages in photosynthesis. The first is light-dependent and takes place in the grana. Sunlight energy is “captured” by chlorophyll in

the chloroplasts and converted into chemical energy in the form of ATP. This process also splits up water into oxygen and hydrogen, with oxygen being released as a waste product. The second, light-independent stage, takes place in the stroma. Carbon dioxide is combined with hydrogen, using energy from ATP to produce glucose.

Sunlight, which is absorbed by chloroplasts in the leaf, provides the energy for photosynthesis

The leaf is the main site of photosynthesis. Its broad, thin lamina is an adaptation for this process

Glucose molecule

Glucose is a high-energy product of photosynthesis and is stored as starch

Oxygen, a waste product of photosynthesis, leaves the leaf through stomata on the lower surface of the lamina

Oxygen molecule

Lamina (leaf blade)

Petiole (leaf stalk)

Water, a raw material in the soil, travels to the leaf from the roots via the xylem

Carbon dioxide, a raw material in the air, enters the leaf through stomata on the lower surface of the lamina

Carbon dioxide molecule

Water molecule

INTERNAL PLANT ANATOMY AND TRANSPORT SYSTEMS

Leaves, shoots, and roots are all covered with an outer epidermis, which prevents water loss and protects against disease. Water vapor is constantly lost through stomata (pores) in the lower epidermis. This process, called transpiration, draws water into the leaves through the

xylem of the roots and stem. Stems and shoots support the plant and carry water from the roots to the leaves, and nutrients from the leaves to other parts of the plant. Roots anchor the plant in the soil and absorb water and mineral salts from soil water.

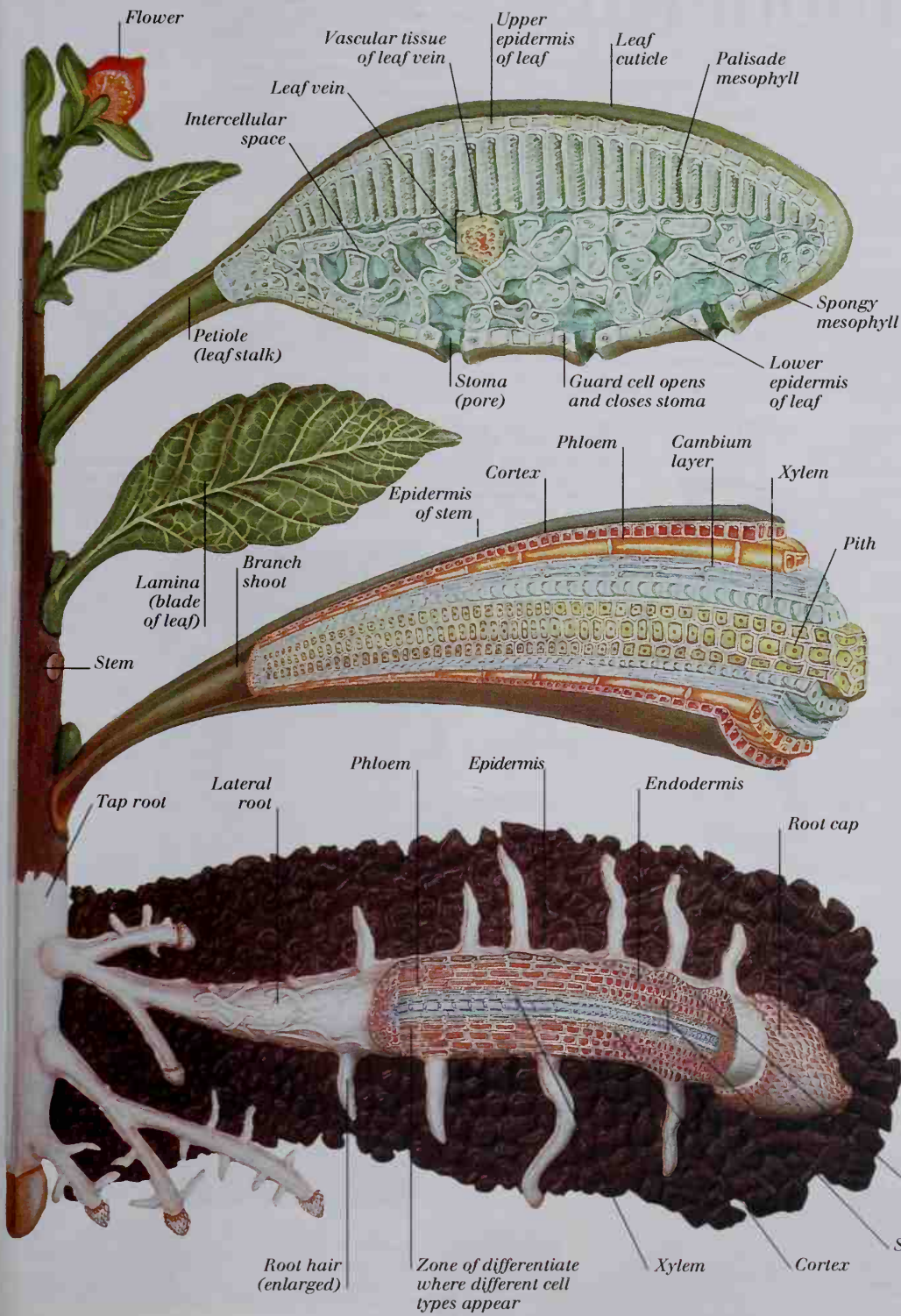

SECTION THROUGH A LEAF
The two main cell layers in a leaf are: the palisade mesophyll, column-shaped cells packed with chloroplasts; and the spongy mesophyll, irregularly shaped cells with fewer chloroplasts separated by air spaces. Veins in the leaf contain xylem and phloem that carry water and minerals into leaves, remove the products of photosynthesis, and provide support for the leaf.

SECTION THROUGH A SHOOT
A herbaceous shoot is surrounded by an epidermis and consists of an outer cortex and an inner pith, which contain packing and supportive tissue. The vascular tissue is arranged in bundles, called vascular bundles, which contain xylem, phloem, and other strengthening tissue. The vascular bundles transport materials and help keep the stem upright.

SECTION THROUGH A ROOT
The growing point of the root, the root tip, contains constantly dividing cells and is protected by a root cap. Behind the root tip, newly produced cells elongate and differentiate. The central cylinder of vascular tissue, the stele, is surrounded by packing tissue which helps the root to resist compression as it pushes through the soil. Root hairs – extensions of the epidermis – absorb water and mineral salts.

Sponges, cnidarians, and echinoderms

SPONGES, CNIDARIANS, AND ECHINODERMS are aquatic animals that belong to three very different **phyla**. Sponges, the simplest of all animals, are sessile and live firmly attached to a rock or coral reef. They extract food particles from water currents that pass through them. Cnidarians, which include hydras and corals, exhibit **radial symmetry** and are either polyps – sessile and fixed by their base to an object – or medusae – bell-shaped and free-swimming. Both forms have a single opening, the mouth, which is surrounded by tentacles armed with unique stinging cells called cnidocytes. Echinoderms, “spiny-skinned” animals, are exclusively marine. They show **pentaradial symmetry** and have an internal skeleton made from calcareous ossicles (plates). They use external, **protrusible tube feet** for moving and feeding.

INTERNAL FEATURES OF SPONGES

Sponges are supported by a **mesohyal** (gelatinous matrix), which contains **spicules** (skeletal struts) and is perforated by large numbers of pores (**ostia**). Water constantly passes into the atrium (interior) through the **ostia** and out through a large opening called the **osculum**. **Choanocytes** create a water current and filter out food particles.

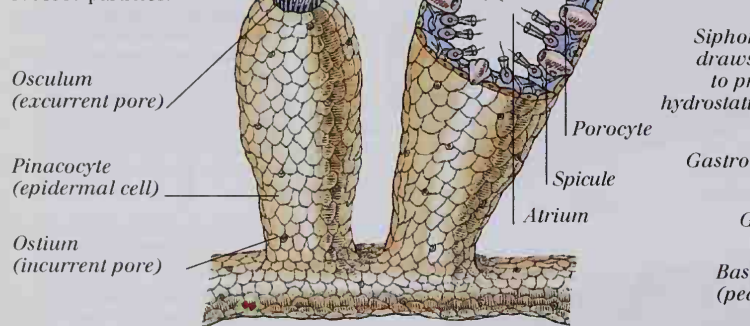

INTERNAL FEATURES OF ANEMONES

Anemones are supported by a **hydrostatic skeleton**, against which the muscular system can act. The mouth opens through the pharynx and into the gastrovascular cavity. This is partitioned by folds, called **septa**, which release enzymes that digest prey taken in through the mouth.

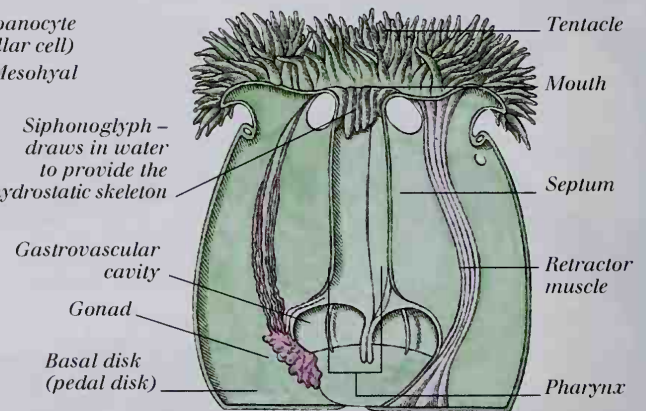

EXAMPLES OF CNIDARIAN TYPES

ANEMONES

Anemones are solitary, polypoid cnidarians. They have thick, column-shaped bodies with a suckerlike basal disk that is used to attach them to solid objects. Tentacles are used to catch passing prey and pull it toward the mouth. They can be retracted into the column to protect them from predators.

MEDITERRANEAN SEA ANEMONE (*Condylactis* sp.)

GREEN SNAKELOCK ANEMONE (*Anemonia viridis*)

BEADLET ANEMONE (*Actinia equina*)

GHOST ANEMONE (*Actinotheria sphyrodeta*)



JELLYFISH

These are medusoid cnidarians that swim actively by alternately contracting and relaxing their bell-shaped body. Trailing tentacles and oral arms catch prey, such as small fish, and pull it into the mouth on the underside of the bell.

STRUCTURE OF A CNIDOCYTE

Cnidocytes are cells that are found in the tentacles of cnidarians. If an animal touches the **cnidocil**, the **operculum** flies open and the **nematocyst** (stinging structure) is discharged. The thread of the **nematocyst** injects a **paralyzing poison**, and **hooks** secure the prey as it is pulled toward the cnidarian's mouth.

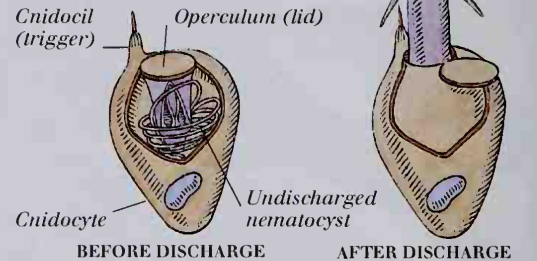

INTERNAL FEATURES OF ECHINODERMS

The echinoderm digestive system consists of the mouth, a stomach from which pairs of pyloric ceca radiate, an intestine, and an anus. The water vascular system, which is unique to echinoderms, consists of a ring canal and paired radial canals. These give rise to pairs of sacs called ampullae, each of which is connected to a tube foot. When the ampulla is squeezed the sucker-tipped tube foot extends; this enables the starfish to move or grasp food.

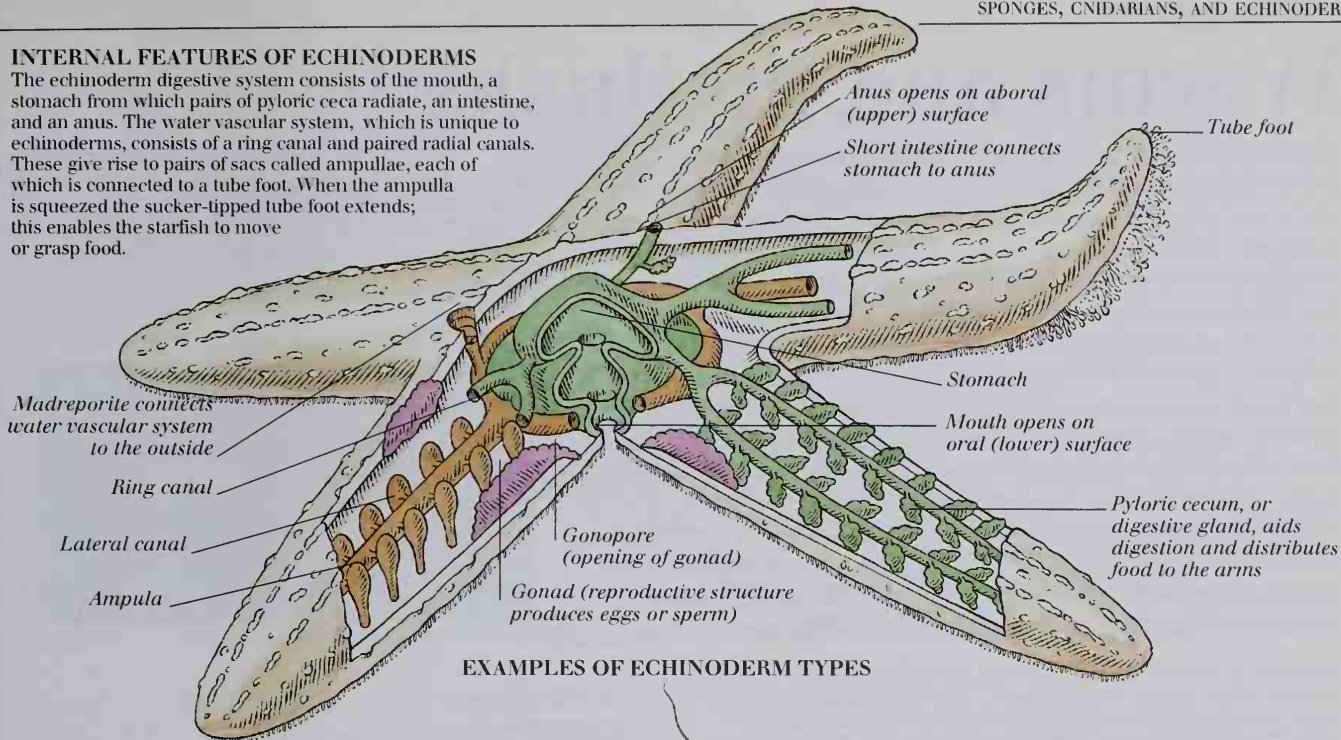

EXAMPLES OF ECHINODERM TYPES

COMMON BRITTLE STARS
(*Ophiothrix fragilis*)



BRITTLE STARS

These small echinoderms have five slender, flexible arms attached to a central disk. If attacked by a predator, brittle stars are able to shed an arm in order to escape – a new one will then grow back in its place. They live on the seabed and feed on algae or fragments of dead animals, using their tube feet to pass food to the mouth, which is located on the underside of the disk. They move quickly by “rowing” over the sea bottom using their flexible arms.

Anus on aboral (upper) surface

Tube foot

Spine

EDIBLE SEA URCHIN
(*Echinus esculentus*)

SEA URCHINS
Sea urchins have a hard, spherical body covered by movable spines that are used for defense and movement. The hard, internal skeleton (test) is formed by interlocking plates. Five rows of tube feet, which emerge through holes in the test, are used as sensors, for movement, and for attachment to surfaces. The mouth is surrounded by five “teeth,” which scrape off algae as the sea urchin creeps over rocks.

SEA CUCUMBERS

Sea cucumbers have a soft, flexible body that lacks arms or spines. It is divided lengthwise by five rows of tube feet: those on the upper surface are usually shorter; those on the lower surface are used to creep along the sea bottom. The mouth is surrounded by a ring of enlarged, branching tube feet, called tentacles. Sea cucumbers trap tiny food particles using these tentacles and push them into their mouth to wipe off the particles.

Row of tube feet

Anus

Elongated, soft body with little internal skeleton

SEA CUCUMBER

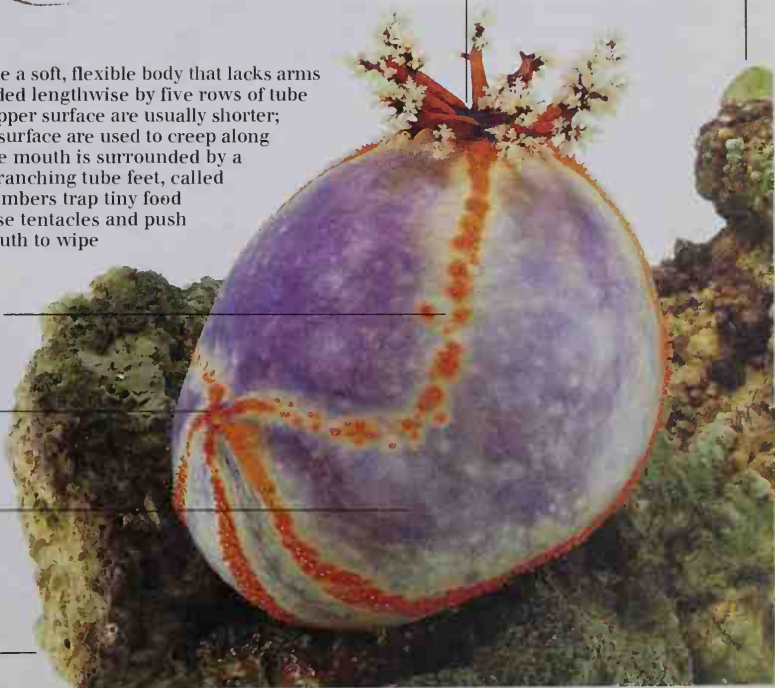

Worms and mollusks

WORMS AND MOLLUSKS ARE SOFT-BODIED, **invertebrate** animals. "Worm" is a general term that includes several **phyla**. Two such phyla are: phylum Annelida (earthworms, marine worms, and leeches), which have segmented, cylindrical bodies with a body cavity (coelom) surrounding the digestive system; and phylum Platyhelminthes (flatworms, tapeworms, and flukes), which have flattened, unsegmented bodies with a single body opening. Mollusks (phylum Mollusca) typically have a head, a muscular foot used in movement, and a visceral hump containing most internal organs. Many mollusks secrete a calcereous shell from their mantle to protect their soft, moist bodies. There are three main mollusk classes: snails and slugs (class Gastropoda), which creep along on a muscular foot and feed using a rasplike radula; clams, scallops, and mussels (class Bivalvia), which are aquatic filter feeders; and squid, octopus, and nautilus (class Cephalopoda), which are free-swimming marine predators.

EARTHWORM REPRODUCTION

Earthworms are hermaphrodites – each has both male and female reproductive organs. During reproduction two worms face in opposite directions, held together by a mucus wrap that they secrete. Each worm releases sperm, which is stored by the other. After a few days, they secrete cocoons into which eggs are laid and fertilized externally by the stored sperm.



INTERNAL FEATURES OF ANNELID WORMS

Annelid worms, such as this earthworm, have a fluid-filled body cavity divided internally into segments by transverse folds called septa. The digestive system - pharynx, esophagus, crop, gizzard, and intestine - passes through the septa from the mouth to the anus. Waste is excreted by one pair of nephridia in each segment. Blood, which is pumped by pseudohearts, surrounds the esophagus and circulate along a dorsal vessel through branches in each segment before returning along the ventral vessel. The nervous system consists of a "brain" and a ventral nerve cord, with branches in each segment to coordinate movement.

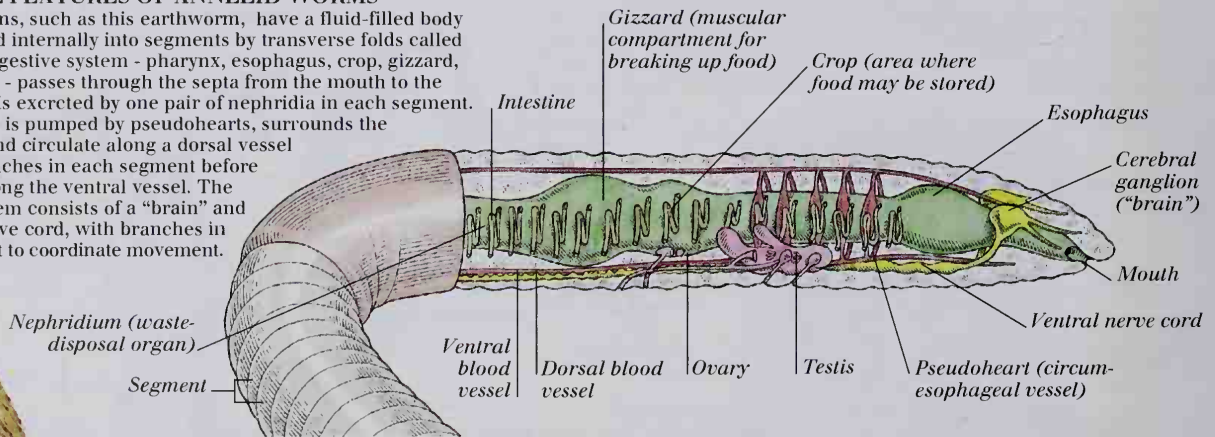

EXAMPLES OF WORM TYPES

FAN WORMS

Fan, or peacock, worms are sedentary polychaetes (marine annelids) that build tubes in which to live. Long processes form a funnel-shaped crown around the head to trap food particles from seawater. These are passed to the mouth by the movements of hairlike cilia. If predators approach, the fanworm can retreat into its tube.

Sticky mucus on long processes traps food particles

Tube constructed of grains of sand and mucus

FAN WORMS
(*Sabella sp.*)

Funnel-shaped crown

Body can be several meters long

Scolex



TAPEWORMS

Tapeworms are parasitic flatworms that live, as adults, in the intestines of vertebrates. The tiny "head" (scolex) has hooks and suckers, that attach it to the host's intestinal wall. The body consists of reproductive segments (proglottids), which leave the host's body in feces when they are ripe and filled with eggs.

INTERNAL FEATURES OF GASTROPODS

The snail's digestive system consists of the mouth (which contains a radula for rasping vegetation), a grinding stomach, a digestive gland, an intestine, and an anus. The mantle cavity, modified to form a lung, takes in oxygen. A simple heart pumps blood from the lung to the head, foot, and other tissues. The cerebral ganglion receives input from sense organs, such as the eyes, and coordinates movement. Snails are hermaphrodites and the ovotestis produces both eggs and sperm.

Visceral mass is protected by a calcareous (chalky) shell

Kidney

Stomach

Anus

Muscular foot enables gastropod to creep along

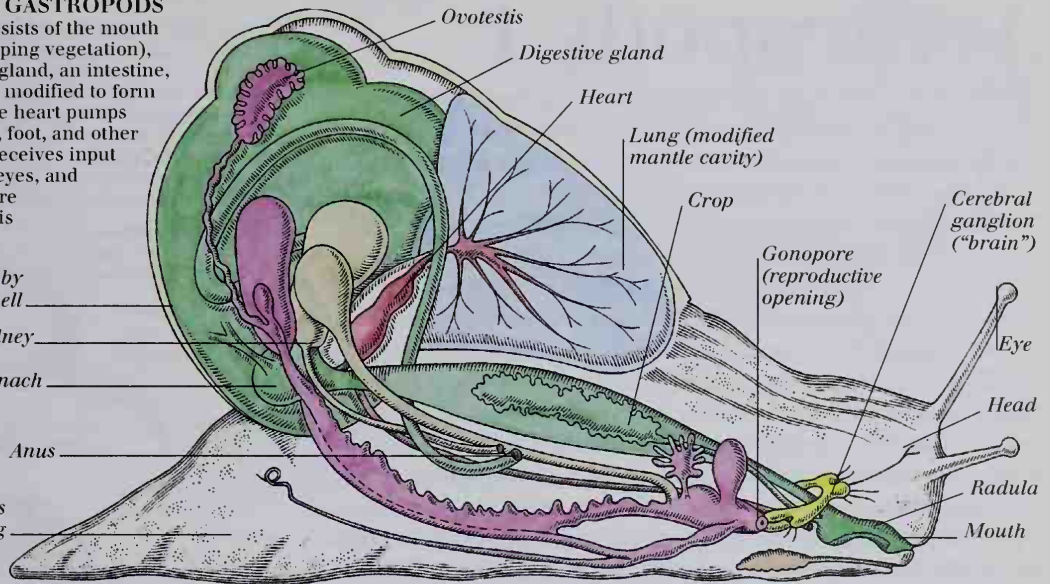

EXAMPLES OF MOLLUSK TYPES

BIVALVES

These aquatic mollusks have a shell with two halves, or valves, connected by a hinge, into which their body can be withdrawn. Most feed by filtering tiny particles from water drawn into the shell. Many bivalves attach themselves to rocks or burrow in sand. Scallops are free-swimming and move by clapping their two valves together.

Lower valve

Ocellus (eye)



SIDE VIEW

SCALLOP
(*Pecten sp.*)

Upper valve

Valves close firmly to enclose entire body



OVERHEAD VIEW

Cerata (folds through which sea slug breathes)



SEA SLUGS

Sea slugs, like snails, are gastropods, but they lack a shell or mantle cavity. Many are brightly colored, advertising to potential predators that they are poisonous or distasteful. Most sea slugs are predatory, grazing on corals and other small animals. The lettuce slug, seen above, feeds on algae and incorporates algal chloroplasts into its body where they continue to photosynthesize.

OCTOPUSES

Like other cephalopods, such as squid and cuttlefish, octopuses are intelligent predators capable of rapid movement. The cephalopod head has well-developed eyes and a horny beak for tearing apart prey. It is attached to a circle of prehensile, sucker-bearing tentacles (eight in the octopus), which are used to capture prey. Octopuses are bottom dwellers and generally move by crawling. If threatened, they move rapidly, through jet power, by forcing water out through the siphon.

Visceral hump

Large eye with horizontal iris

Siphon

Head

Tentacle

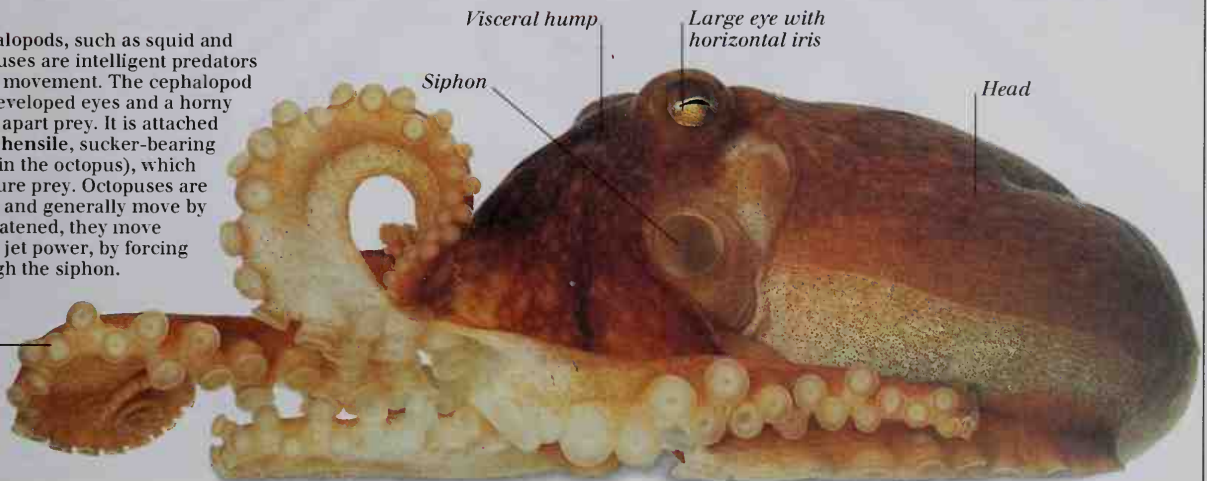

Arthropods 1

ARTHROPODS (PHYLUM ARTHROPODA) form the largest and most diverse animal group. An arthropod's body and limbs are completely covered by an exoskeleton (external skeleton), or cuticle, which consists of inflexible plates that meet at flexible joints. Arthropods are divided into three subgroups (subphyla) – crustaceans, chelicerates, and uniramians. Crustaceans (subphylum Crustacea) are mostly marine animals. Their bodies consist of a head, with **compound eyes** and two pairs of **antennae**, and a trunk, made up of a **thorax**, an abdomen, and several pairs of jointed appendages. The major classes include: lobsters and crabs; barnacles; and water fleas. The chelicerates (subphylum Chelicerata) have bodies divided into a cephalothorax and an abdomen. The cephalothorax bears a pair of feeding appendages (chelicerae), a pair of **pedipalps**, and four pairs of legs. The largest of the three chelicerate classes is the arachnids, which includes spiders, scorpions, harvestmen (or daddy longlegs), and ticks. The uniramians (subphylum Uniramia) include insects, millipedes, and centipedes (see pp. 156-157).

WALKING MECHANISMS OF AN ARTHROPOD

An arthropod limb consists of tubular plates connected by articular membranes, which form flexible joints. Sets of muscles attached across the joint between limb and body move the whole limb up and down, or back and forth. Opposing muscles, which cross joints within the limb, flex or extend the particular joint they cross. Collectively, the combined contractions or relaxations of muscle groups enable the animal to walk in a coordinated way.

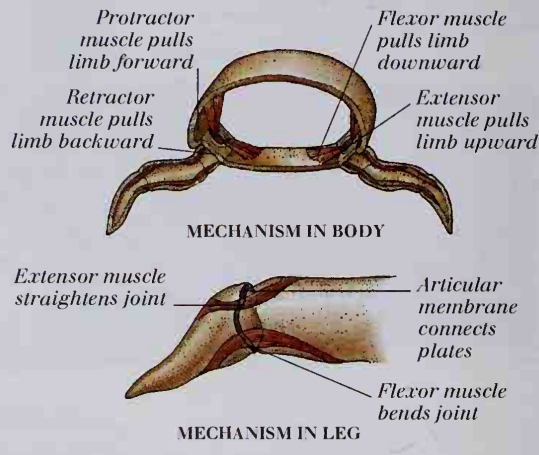

CRUSTACEANS

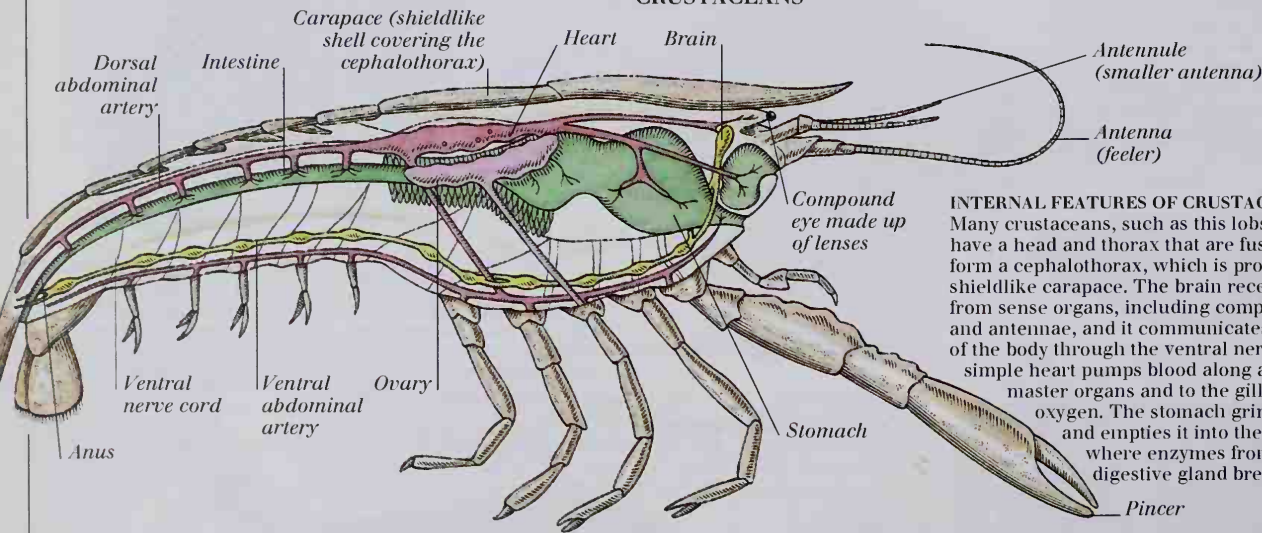

INTERNAL FEATURES OF CRUSTACEANS
Many crustaceans, such as this lobster, have a head and thorax that are fused to form a cephalothorax, which is protected by a shieldlike carapace. The brain receives input from sense organs, including compound eyes and antennae, and it communicates with the rest of the body through the ventral nerve cord. A simple heart pumps blood along arteries to the master organs and to the gills to pick up oxygen. The stomach grinds up food and empties it into the intestine, where enzymes from the digestive gland break it down.

EXAMPLES OF CRUSTACEAN TYPES

Internal organs are visible through transparent carapace

WATER FLEAS

These small, freshwater crustaceans have laterally flattened, transparent bodies. Frilled appendages, attached to the trunk, are used to filter food from the water. Water fleas move by flicking their antennae.

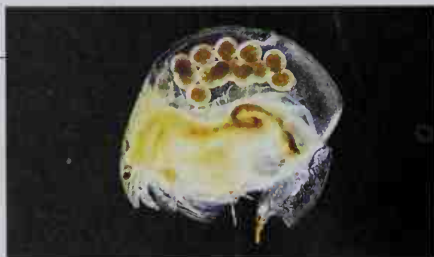

WATER FLEA
(*Turycecus lamellata*)

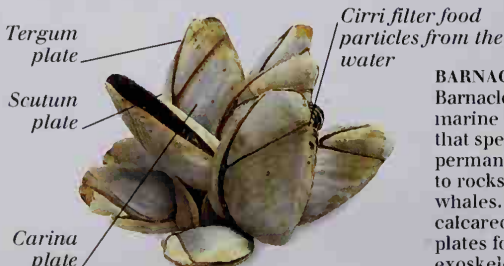

STALKED BARNACLE
(*Lepas sp.*)

Cirri filter food particles from the water

BARNACLES

Barnacles are sedentary, marine crustaceans that spend their lives permanently attached to rocks, boats, or even whales. Overlapping calcareous (chalky) plates form the exoskeleton, which surrounds and protects the animal.

ARACHNIDS

INTERNAL FEATURES OF ARACHNIDS

Scorpions capture their prey with pedipalps modified to form powerful claws. The prey is then torn apart by the chelicerae and soaked in digestive juices. The muscular foregut sucks in the liquefied food, the midgut completes digestion within the animal, and the hindgut expels waste. Air enters the book lungs through openings in the thorax and abdomen called spiracles. The posterior abdomen forms an arched "tail" at the tip of which is a sting; glands at the base of the sting produce venom, which is used to subdue prey.

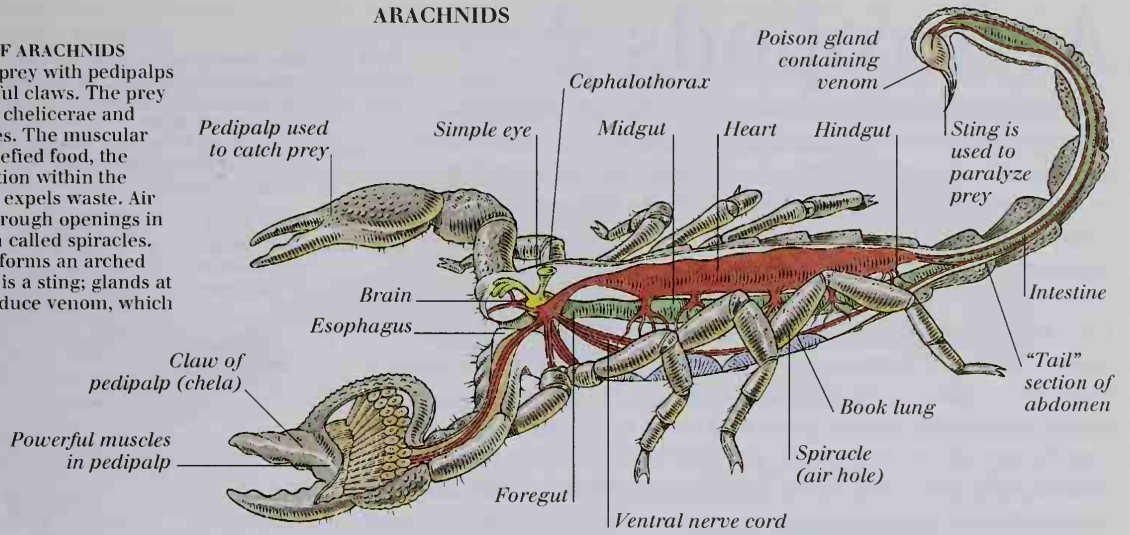

EXAMPLES OF ARACHNID TYPES

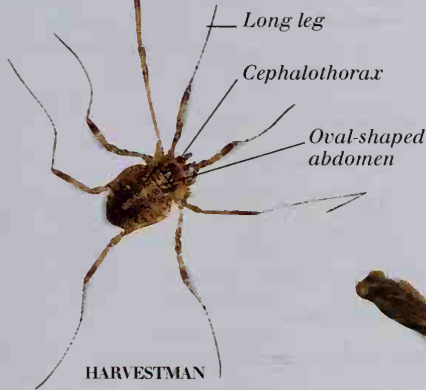

HARVESTMEN

Harvestmen inhabit damp, shaded areas of vegetation in tropical and temperate regions of the world. They have an oval-shaped body and long, thin legs. They feed on small invertebrates and scavenge for dead plant and animal material. Unlike other arachnids, harvestmen can ingest small food particles that are then digested in the gut.



SHEEP TICK (*Ixodes ricinus*)

TICKS

Ticks are small, parasitic arachnids that live on the blood of land-living vertebrates. They puncture the host's skin, using serrated chelicerae, and work their toothed mouthparts into the wound. As they feed, their bodies expand (see above).

SPIDERS

The most successful and abundant arachnids are the spiders. Their bodies consist of a distinct cephalothorax joined to the abdomen by a waistlike pedicel. They have four pairs of walking legs and a pair of leglike pedipalps, which act as sensory organs. Spiders produce silk, which is released from spinnerets at the tip of the abdomen. This may be used to produce egg cocoons, for building nests, and, in some species, to construct webs. All spiders are carnivorous, and most feed on insects. They pump digestive enzymes into paralyzed prey and then suck out the resulting juices.



Arthropods 2

ARTHROPODS ARE INVERTEBRATES that have a segmented exoskeleton (external skeleton), or cuticle. The three main groups are: uniramians, which include insects, millipedes, and centipedes; crustaceans; and chelicerates (see pp. 154-155). Uniramians are mainly **terrestrial** and breathe air through **spiracles**. Insects (class Insecta) have bodies divided into three parts: a head; a thorax, which has three pairs of legs and typically two pairs of wings; and an abdomen. During their life cycle, insects undergo **metamorphosis**. Some, such as grasshoppers, show incomplete metamorphosis: young hatch from eggs as miniature adults, which grow and **molt** until they reach adult size. More advanced insects, such as beetles, show complete metamorphosis: young hatch from eggs as larvae, which undergo reorganization in a **pupa** and emerge as adults. Centipedes (class Chilopoda) and millipedes (class Diplopoda) have a body that consists of a head and trunk. Their cuticle lacks a waxy layer, and they are found mainly in humid habitats, such as leaf litter.

COMPOUND EYES

Most insects, and many crustaceans (see p. 154), have compound eyes, which are made up of long, cylindrical units called ommatidia. These consist of an outer, transparent lens-cornea and a crystalline cone, which focus light into the inner rhabdome. This contains light-sensitive cells, which, when stimulated by light, send nerve impulses to the brain.

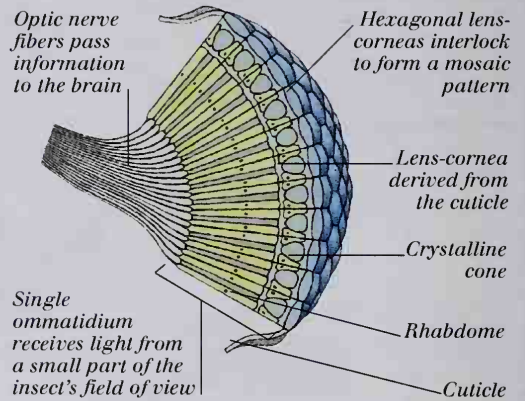

ANATOMY OF INSECTS

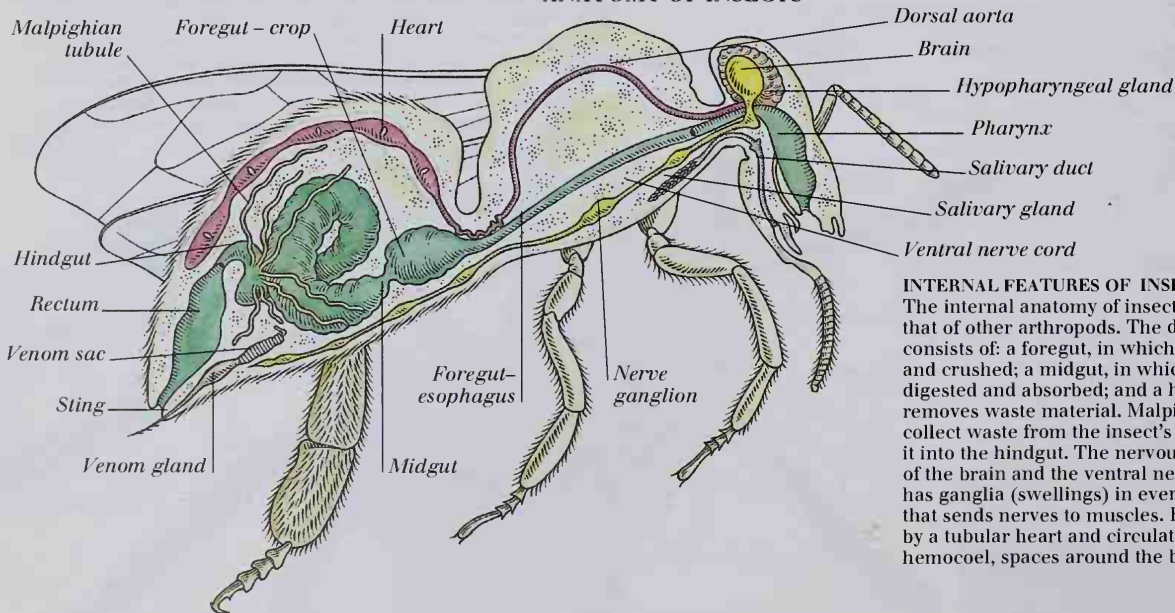

INTERNAL FEATURES OF INSECTS

The internal anatomy of insects is similar to that of other arthropods. The digestive system consists of: a foregut, in which food is stored and crushed; a midgut, in which food is digested and absorbed; and a hindgut, which removes waste material. Malpighian tubules collect waste from the insect's blood and empty it into the hindgut. The nervous system consists of the brain and the ventral nerve cord, which has ganglia (swellings) in every body segment that sends nerves to muscles. Blood is pumped by a tubular heart and circulates within the hemocoel, spaces around the body organs.

INSECT WINGS

A majority of insects have wings; most have two pairs – forewings and hindwings. The insect wing consists of two thin layers of cuticle, which form the upper and lower surfaces. They are separated by veins that support the wing and supply it with blood. Wings vary greatly in size, shape, and color. Apart from flying, wings may also be used to attract a mate, act as camouflage, and to warn predators that the insect may be poisonous.

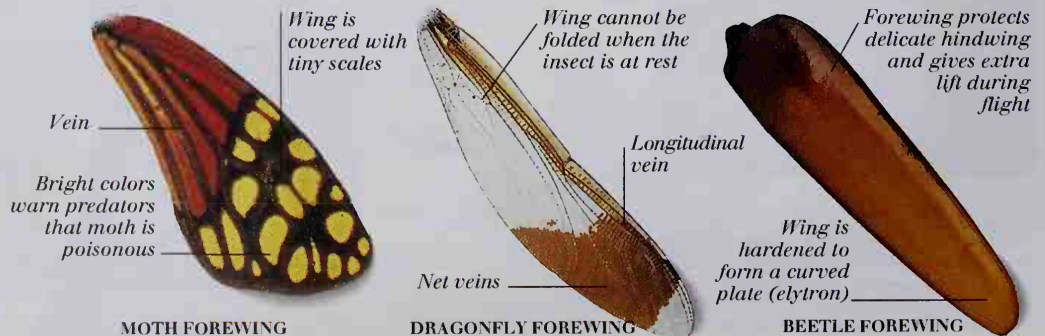

LADYBUG METAMORPHOSIS

Like all beetles, ladybugs undergo complete metamorphosis. Eggs laid by the female hatch to produce larvae that feed on other insects. They grow rapidly, molting several times, and eventually form a pupa.

The larval tissues reorganize within the pupa, and the pupal skin splits open to reveal the young, adult ladybug. Its soft wing cases harden within a few hours and, once its wings have expanded, it can fly.

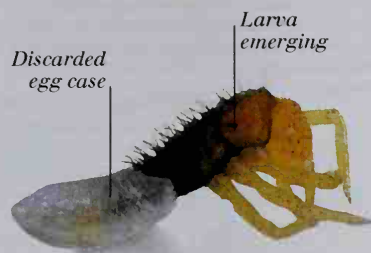

LARVA HATCHING FROM EGG



LARVA ATTACHES ITSELF TO LEAF PRIOR TO PUPATION

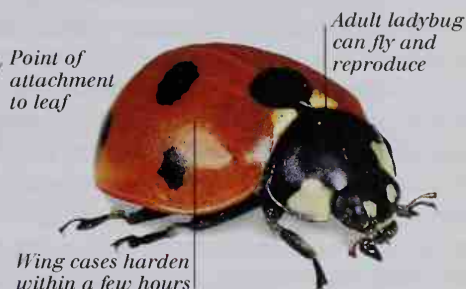

ADULT LADYBUG

EXAMPLES OF INSECT TYPES

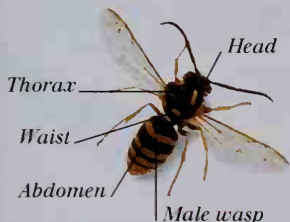

WASPS

Tree wasps, like ants, some bees, and other wasps, are social insects that live together in a nest. Within the tree wasp colony, there are three types (castes) of individuals: the queen (a fertile female) that lays eggs; workers (sterile females) that tend the nest and hunt for caterpillars to feed wasp larvae; and males that fertilize the queen.



TREE WASPS

(*Dolichovespula sylvestris*)



CAT FLEA

(*Ctenocephalides felis*)

FLEAS

Fleas are small, parasitic, wingless insects that, as adults, live on the skin of birds and mammals. They feed by pushing their stylets (piercing mouthparts) through the host's skin and sucking blood. Flea larvae live in the host's nest or bedding and feed on dried blood.

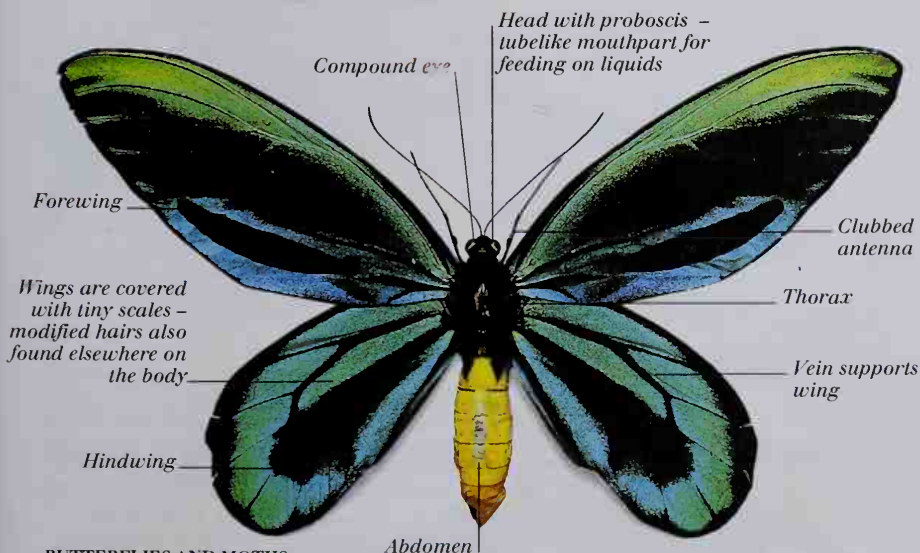

BUTTERFLIES AND MOTHS

Butterflies and moths have large, paired wings. The adults feed on liquids, particularly nectar from flowers, and the larvae, called caterpillars, feed on leaves and other plant parts. Butterflies typically have brightly colored wings, clubbed antennae, and fly by day; moths are usually duller in color, have feathery antennae, and are active at night.

QUEEN ALEXANDRA'S BIRDWING BUTTERFLY
(*Ornithoptera alexandrae*)

CENTIPEDES AND MILLIPEDES

Centipedes have a flattened body with a pair of legs on each trunk segment. They are carnivorous and kill prey using poisonous claws on the underside of their head. Millipedes have a cylindrical body with two pairs of legs on each trunk segment. They use chewing mouthparts to feed on decaying vegetation. Millipedes can roll or coil up to protect themselves against predators.



WOODLAND CENTIPEDE

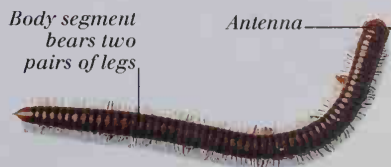

MILLIPEDE

Fish

WITH OVER 25,000 SPECIES, fish are the most successful group of vertebrates (animals with backbones) and can be found in both freshwater and saltwater habitats. They are adapted for life in water by having a streamlined head and a body typically covered with smooth, protective scales that are often coated with slippery **mucus**. These features reduce resistance as they propel themselves through the water. Fish also have fins, projecting structures supported by bony or cartilaginous rays, that are used for propulsion, steering, and stability. Respiratory organs, called **gills**, are adapted for absorbing oxygen from the water. They can be divided, on the basis of external body form and internal structure, into three main groups: the jawless fish (order Cyclostomata); the cartilaginous fish (class Chondrichthyes); and the bony fish (class Osteichthyes) to which the majority of fish belong.

HOW FISH BREATHE

Fish breathe by extracting oxygen from the water using their gills. They take in water through the mouth when the opercula (protective gill flaps) are closed. The mouth then closes and muscles in the mouth cavity contract to push water over the gills and out through the opercula. As water flows over the gills, oxygen passes through the lamellae and into the blood. Waste carbon dioxide diffuses out from the gills and into the water.

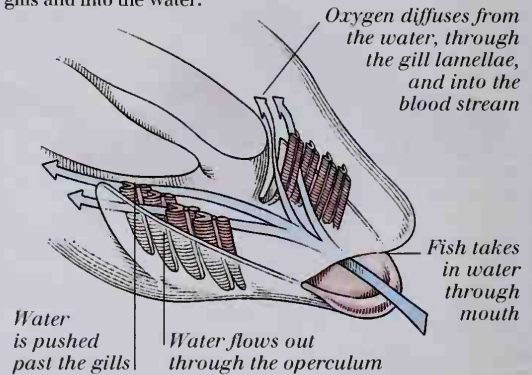

ANATOMY OF BONY FISH

SKELETON OF A BONY FISH

The cod has a typical bony fish skeleton; the main axis of this is a flexible backbone. Muscles attached to either side of the backbone contract to pull the body from side to side and propel the fish forward. The neural and hemal spines and the ribs help maintain the fish's shape during swimming. Dorsal, anal, and caudal (tail) fins and the paired pelvic and pectoral fins are supported by bony rays.

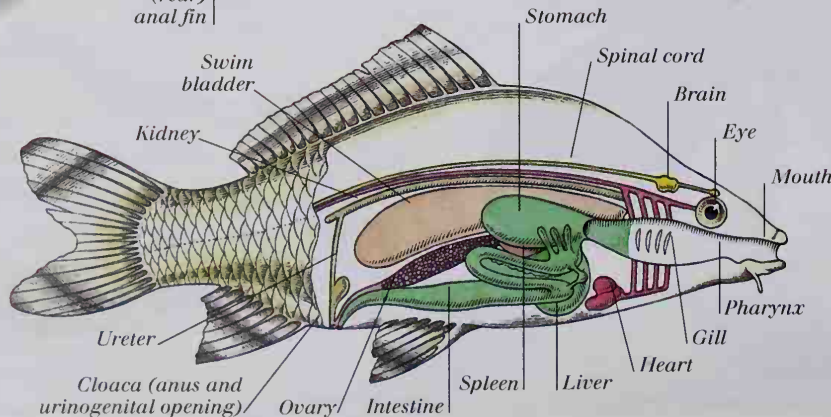
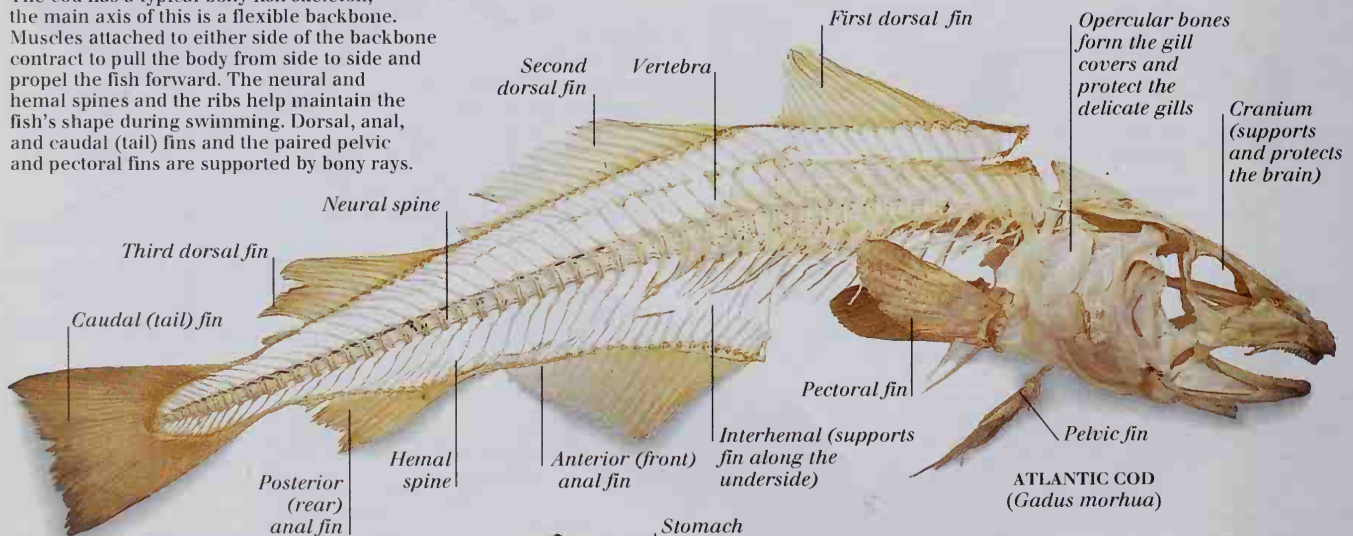

INTERNAL FEATURES OF BONY FISH

Bony fish have internal body systems typical of most vertebrates. Blood is pumped, by the heart, around the body and through the gills to pick up oxygen. The swim bladder, characteristic of bony fish, is a gas-filled sac that allows the fish to be neutrally buoyant, not sink or float, in the water. The fish can therefore maintain its position at any depth.

HOW FISH SWIM

Cartilaginous fish, such as this dogfish, swim by curving the body from one side to the other. This pushes the water sideways and backward and propels the fish forward. Most bony fish keep their

body straighter and beat their tail fin from side to side in order to achieve the same result. Fins enable fish to steer and adjust their level in the water.

The S-shaped wave begins when the dogfish swings its head to one side

The dogfish's body swivels around a point just behind the head

At the end of each wave the tail flicks backward against the water

The head turns right into the next wave



TYPES OF FISH

CARTILAGINOUS FISH: SHARKS

Most cartilaginous fish live in marine habitats and have skeletons made from strong, flexible cartilage. Their bodies are covered with tiny scales, called dermal denticles, which give them a rough, sandpaperlike feel. Both sharks and rays have gill slits instead of an operculum. Typically, sharks are predators, with a long, streamlined body and a mouth with rows of sharp teeth. They lack a swim bladder but their large, oil-filled livers help maintain their position in the water.

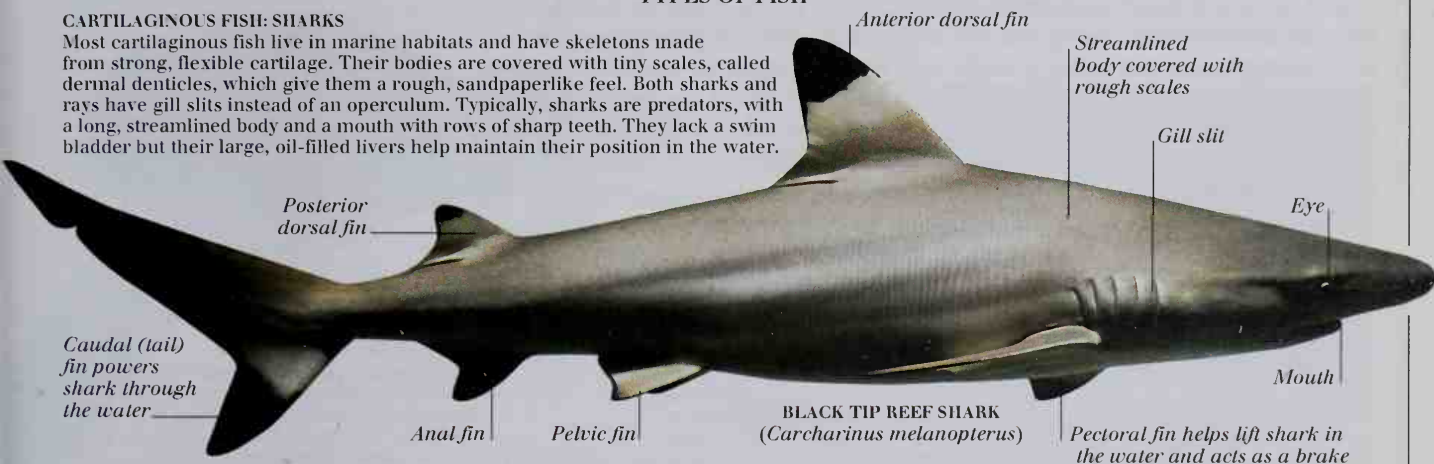

BONY FISH

These are the largest and most diverse group of fish and are found in both sea- and freshwater. They have a skeleton made of bone and a swim bladder to maintain buoyancy. Most have thin scales to protect their body. Their gills are covered by a flap called the operculum.

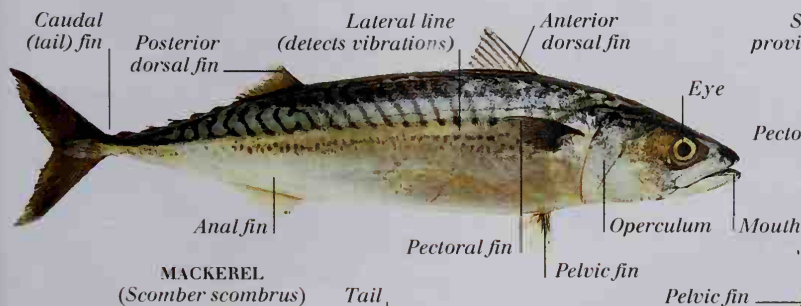

CARTILAGINOUS FISH: RAYS

Rays are cartilaginous fish with flattened bodies and enlarged, winglike pectoral fins that undulate to provide propulsion. Most rays are bottom dwellers, feeding on mollusks and crustaceans with their crushing teeth. Some, such as the large manta rays, "fly" through the water, eating plankton.

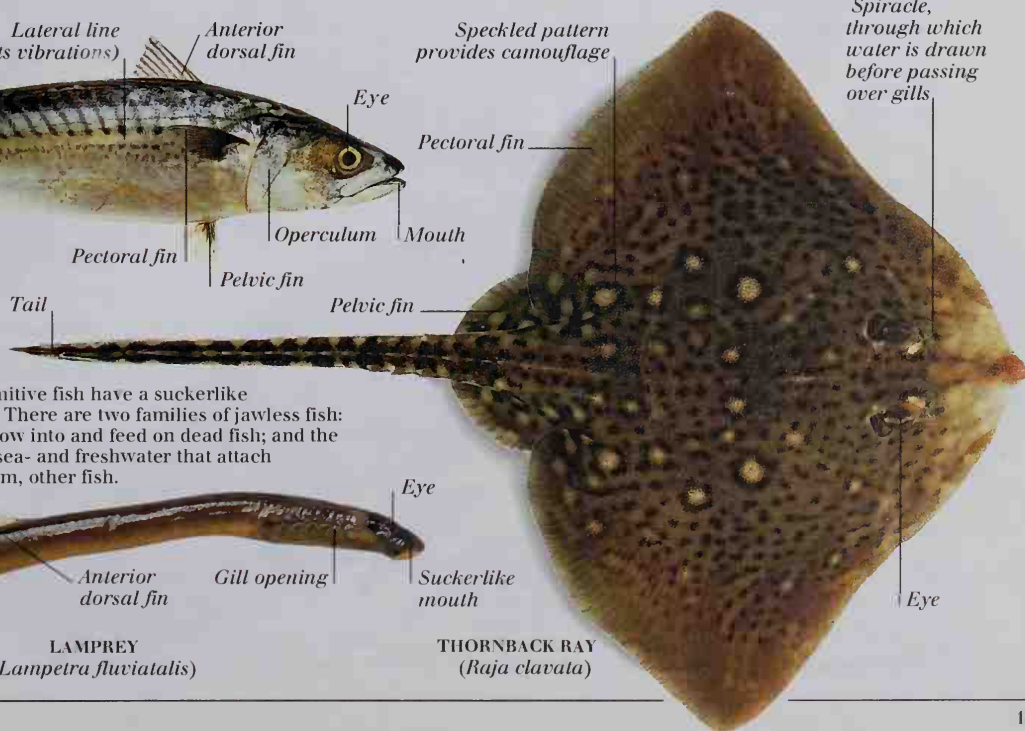

JAWLESS FISH

Instead of hinged jaws, these primitive fish have a suckerlike mouth, with sharp, rasping teeth. There are two families of jawless fish: the hagfish, marine fish that burrow into and feed on dead fish; and the lampreys, parasitic fish found in sea- and freshwater that attach themselves to, and suck blood from, other fish.



Amphibians

AMPHIBIANS ARE VERTEBRATES that typically develop in water. Female amphibians lay eggs, which are **fertilized** externally by the male. Legless larvae, called tadpoles, hatch from the fertilized eggs and undergo metamorphosis – a rapid change from larval form to an air-breathing adult with four legs. Most adults leave the water and then return to it to breed; some never leave and may spend their entire lives in water. As adults, amphibians are **carnivorous** and will eat any animal they can catch, kill, and swallow. They have moist, nonwaterproof, naked skin, and most land-living species live in damp **habitats** to help prevent the skin from drying out. All amphibians are **ectothermic** – their body temperature and activity levels vary with the external temperature. The greatest diversity of amphibians is found in tropical regions, where conditions are warm and moist, although there are also some **temperate** and desert species. There are three groups of amphibians: frogs and toads, which form the largest and most advanced group; salamanders, which includes newts, axolotls, mud-puppies, and sirens; and caecilians – wormlike, legless amphibians found in **tropical** regions.

ANATOMY OF AMPHIBIANS

INTERNAL FEATURES OF AMPHIBIANS

Frogs breathe using paired, saclike lungs and by absorbing oxygen through their skin. Male frogs can amplify the sounds produced in their larynx (voice box) by inflating a vocal sac beneath their mouth. The heart has a single ventricle and two atria; a circulatory system moves the blood around the body. The testes, which produce sperm, share a common duct with the kidneys, which remove waste from the blood. This duct joins with the rectum to form a common opening called the cloaca.

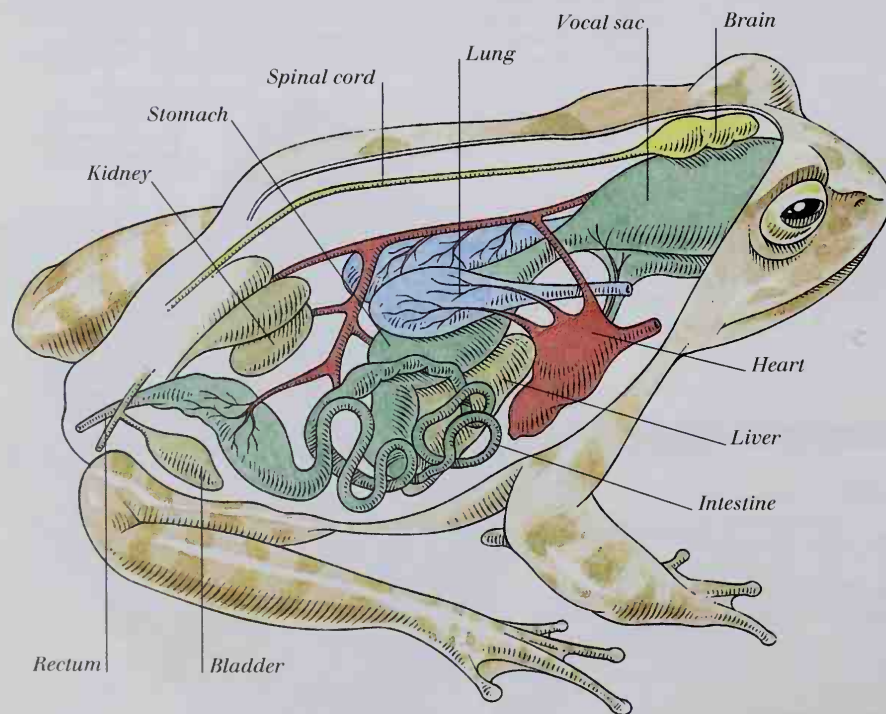

AMPHIBIAN SKIN

Amphibian skin lacks the scales, feathers, and fur found in other vertebrates. Mucus keeps their skin damp and protects it from damage and infection. Amphibians can take in oxygen through their skin to “assist” their lungs in breathing. It is also **permeable** to water and helps to control the amount of water lost or gained by the animal.

Skin of a White's tree frog

Skin is naked, smooth, and covered with mucus



FOOT ADAPTATIONS

Amphibian feet vary considerably according to habitat and lifestyle. Some amphibians are primarily aquatic and have webbed feet for swimming; others may have feet adapted for walking, climbing, gripping, or digging.

Webbed hind foot for swimming



PALMATE NEWT FOOT

Flattened foot for walking and digging



TIGER SALAMANDER FOOT

Sticky disk for gripping leaves and branches



TREE FROG FOOT

Claw for gripping slippery surfaces



Webbed foot for swimming

CLAWED TOAD FOOT

FROG METAMORPHOSIS

Frogs and toads undergo a complete change in body form during metamorphosis. When the tadpole hatches from its egg, it feeds on vegetation and breathes using gills. Six to nine weeks after hatching, the

hind legs appear and the tadpole begins to eat dead animals. Gradually the front legs emerge, the tail is absorbed, and the body shape becomes froglike. Lungs develop internally, and the frog is ready for life on land.

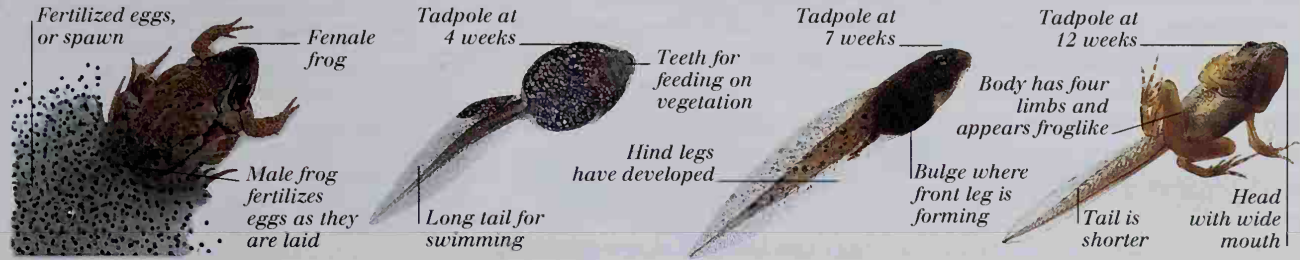

TYPES OF AMPHIBIANS

Crest is used in courtship displays

Short leg

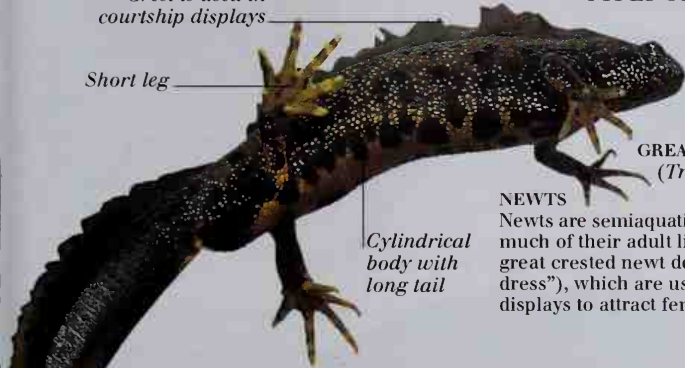

Long, flexible body

Streamlined head with small eyes

GREAT CRESTED NEWT (*Triturus cristatus*)

NEWTs

Newts are semiaquatic salamanders that spend much of their adult lives in water. The male great crested newt develops crests ("breeding dress"), which are used in elaborate courtship displays to attract females.

Cylindrical body with long tail

Silvery stripe on male's tail is used to attract females



CAECILIANS

Caecilians are wormlike, legless amphibians. Most burrow in the soft soil and leaf litter of tropical forest floors and some live in water. Burrowing caecilians (see above) feed on earthworms and other soil invertebrates.

Warty skin typical of toads

Skin patterns and color provide camouflage

Squat, tailless body



TOADS

Toads, like frogs, are tailless amphibians with short, compact bodies, large heads, bulging eyes, and wide mouths. Unlike frogs, toads typically have dry, warty skin and spend most of their adult life away from water. Their feet are not webbed, and they move by walking or in short hops.

Brightly colored paratoid (poison gland) warns off predators

EUROPEAN FIRE SALAMANDER (*Salamandra salamandra*)

Cylindrical body

Narrow head with small eyes



Short leg

Hind foot moves at the same time as opposite front foot

Long tail

SALAMANDERS

As adults, most salamander species are terrestrial. They move slowly by bending their body from side to side, in a fishlike motion. Some salamanders, such as this fire salamander, ooze a poisonous secretion if attacked; their brightly colored skin acts as a warning to deter predators.

Reptiles

REPTILES FORM A HIGHLY VARIED class of mainly land-living vertebrates. There are four orders: tortoises and turtles, including river turtles (terrapins); snakes and lizards, the largest reptile order; the tuataras, two lizardlike species found in New Zealand; and the crocodylians (crocodiles, alligators, caimans, and gavials). Typically, reptiles have scaly, waterproof skin that helps them to retain water and survive in hot, dry habitats. To permit growth, the skin is shed periodically either as flakes, as in lizards, or in one piece, as in snakes. Most reptiles are **oviparous** and lay eggs (on land) that are protected by a shell. Within the egg the **embryo** is contained in a fluid-filled sac (amnion), which prevents it drying out. Usually, female reptiles lay their eggs and leave them, but crocodylians lay their eggs in a nest and show **parental care** after hatching. Reptiles are **ectothermic**, depending on external warmth to keep them active. Most live in tropical or subtropical regions, where they bask in the morning sun in order to raise their body temperature.

JACOBSON'S ORGAN

Snakes and some lizards use a sense organ called the Jacobson's organ for detecting smells. This is located in the roof of the mouth and smells, or tastes, airborne chemicals picked up by the continually flicking tongue. As snakes have poor eyesight, smell is important to find prey, taste food, detect enemies, and find a mate.

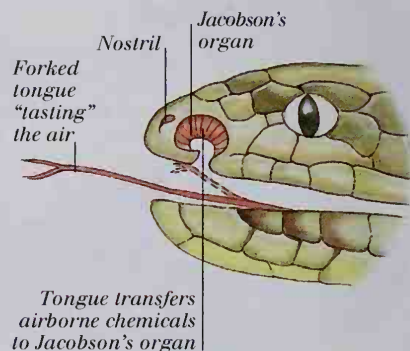

ANATOMY OF REPTILES

SKELETON OF A TORTOISE

Like other reptiles, tortoises have a bony endoskeleton (internal skeleton). They also have a hard, protective shell, which encloses their body and into which the head, limbs, and tail, can be retracted. This consists of an inner layer of bony plates that are fused to the ribs and trunk vertebrae, and an outer layer of horny shields (scutes), which are comparable to the scales of other reptiles.

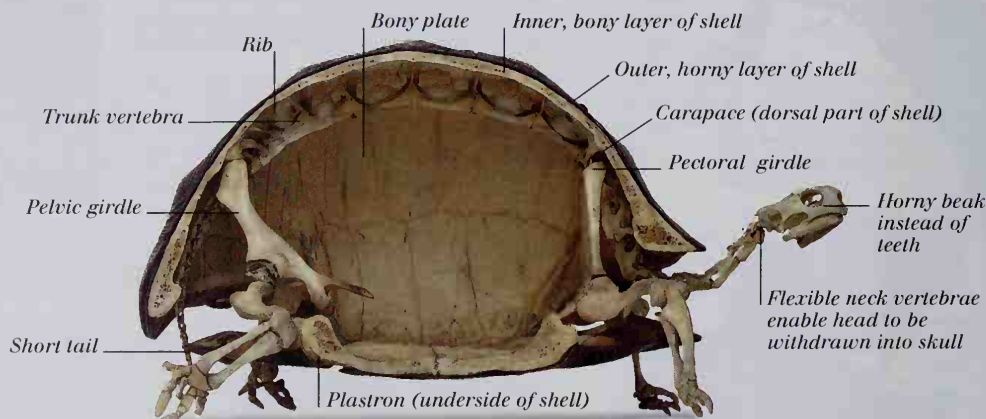

RADIATED TORTOISE (*Testudo radiata*)

INTERNAL FEATURES OF REPTILES

The lizard has an internal structure similar to most reptiles. Its brain is relatively small but permits fairly complex behavior patterns. Food is broken down in the digestive system prior to absorption. The heart, with its single ventricle and two atria, pumps the blood around the body. Eggs are produced, after fertilization, in the female reproductive system. A shell is secreted around each one as it passes down the oviduct. The digestive and reproductive systems empty into a common cloacal chamber.

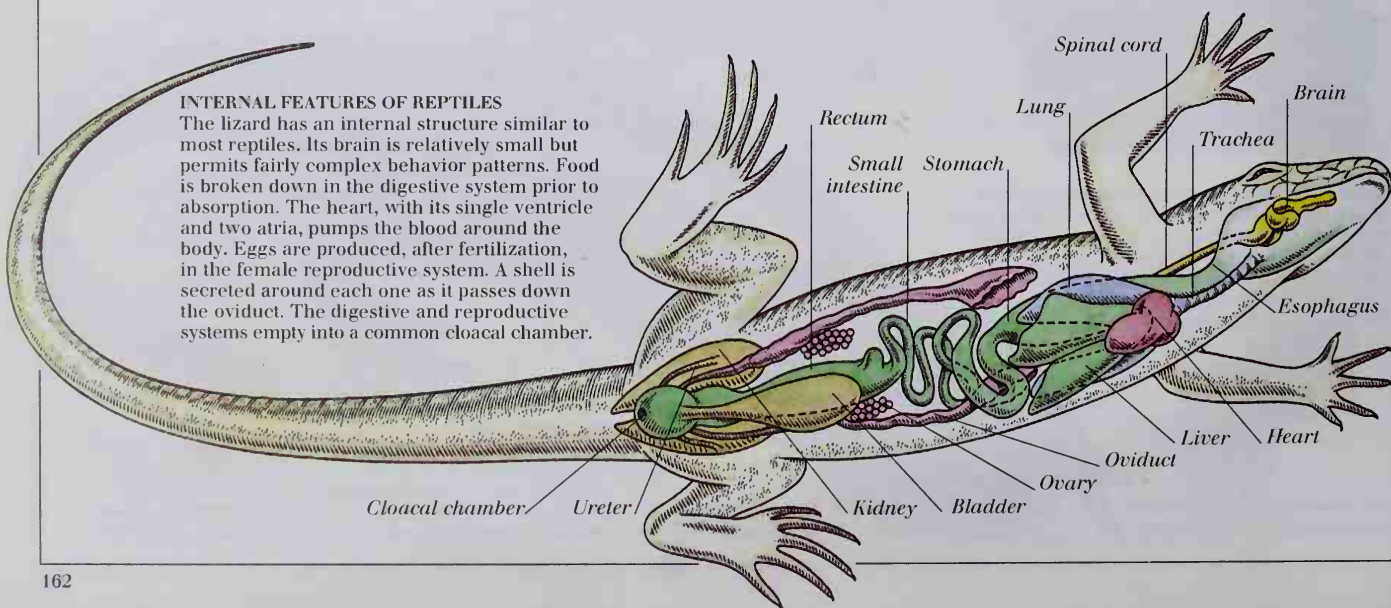

REPTILE EGG HATCHING

Most snakes lay eggs. The female rat snake (see below) lays soft-shelled eggs in material, such as leaf litter, that releases heat as it decays. Inside the egg, the developing embryo snake absorbs nutrients from a sac containing yolk. Between 7 and 15 weeks

after laying, depending on the external temperature, the young rat snake hatches. It uses a temporary "egg tooth" on the upper jaw to break through the eggshell. The hatchling, like all other young reptiles, looks like a smaller version of its parents.

Soft-shelled egg

Hatchling breaks through using egg tooth

Young snake "tastes" air

Snake emerges from shell and leaves it rapidly to avoid discovery by predators.

Snake's long body has been tightly coiled inside the egg

EXAMPLES OF REPTILE TYPES

SNAKES

These legless reptiles have a long body and a flexible backbone. All snakes are carnivores (meat eaters) and can swallow large prey whole. Constrictors, such as boas and pythons, coil around their prey and squeeze it until it suffocates. Venomous snakes, such as vipers and cobras, inject lethal venom (poison) through hollow or grooved fangs (teeth).

Patterned, scaly skin provides camouflage

Snake coils around prey to suffocate it

Prey is swallowed whole and head first

BOA CONSTRICTOR
(*Boa constrictor*)

Strong muscles around a flexible backbone enables snake to move

Lower jaw is loosely attached to skull allowing mouth to open wide and sideways

Old skin must be shed in order for the lizard to grow

Long, legless body

Scaly skin

Head with small eyes

SLOW WORM
(*Anguis fragilis*)

LIZARDS

Typically, lizards are fast-moving hunters that prey on smaller animals. They have four legs, feet with sharp claws, and a long tail to help them balance. A few species, such as this slow worm, are legless. Although most lizards live on the ground, some live in trees, some are burrowers, and a few are aquatic. The majority of lizards, including chameleons and geckos, are insectivores (insect eaters); many larger species, such as iguanas, are herbivores (plant eaters).

CROCODILIANS

Crocodylians are all carnivores that hunt and feed in water. Their long snouts house many sharp teeth used to grasp prey and tear it apart. They have thickened, "armored" scales, four short, strong legs for moving on land, and a powerful, flattened tail used for swimming. Their eyes and nostrils are set high on the head so that they can see and breathe while the rest of the body is immersed and concealed in water.

Powerful, laterally flattened tail

Broad, rounded snout

Sharp tooth

Tongue

Large eyes set high on head

SPECTACLED CAIMAN
(*Caiman crocodilus*)

Body covered by hard scales

Partially webbed foot with sharp claws

Birds

BIRDS ARE THE ONLY ANIMALS that have feathers and, apart from bats, are the only vertebrates capable of powered flight. This has enabled them to become established all over the world, from the hottest deserts to Antarctica. Most birds, apart from the flightless species, have a uniform body plan especially adapted for flight. Modified forelimbs form wings and their bodies are covered with feathers: down feathers **insulate** the bird's body; contour feathers produce a **streamlined** shape; and flight feathers on the wings enable flight and steering. Hollow bones reduce the weight of the skeleton and a light, horny beak has replaced heavy jaws and teeth. The size and shape of the bird's beak depends on its diet. Most birds have feet with four digits and claws that vary according to lifestyle: perching birds have gripping feet, and waterbirds have webbed feet for swimming. All birds lay hard-shelled eggs; most are **incubated** in a nest until they hatch. Like mammals, birds are **endothermic**, with a body temperature of about 40° C. They also have a high **metabolic rate** that reflects the energy demands of flight.

SECTION THROUGH A CHICKEN'S EGG

A shelled egg provides a protective environment for the embryo bird to develop. Within the hard shell, a system of membranes surrounds the embryo: the amnion prevents the embryo from drying out and acts as a shock absorber; the allantois stores waste and, with the chorion, acts as a respiratory surface. Food is provided by the yolk sac.

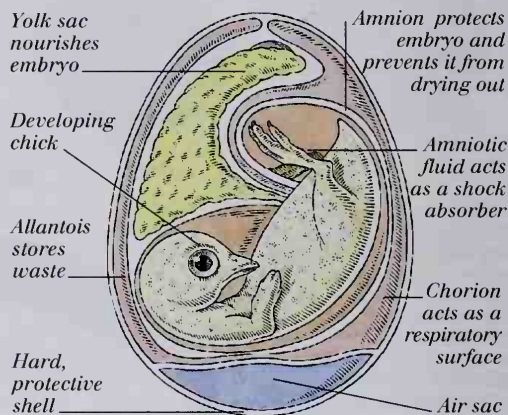

ANATOMY OF BIRDS

INTERNAL FEATURES OF BIRDS

Birds have organs that are unique to their class. The crop is used for storing food, and a muscular bag called the gizzard grinds up food, in the absence of teeth, to a digestible pulp. Plant-eating birds swallow small stones to aid the grinding action of the gizzard. The lungs are linked to extensive air sacs that improve their efficiency and increase the uptake of the oxygen needed to release energy for flight.

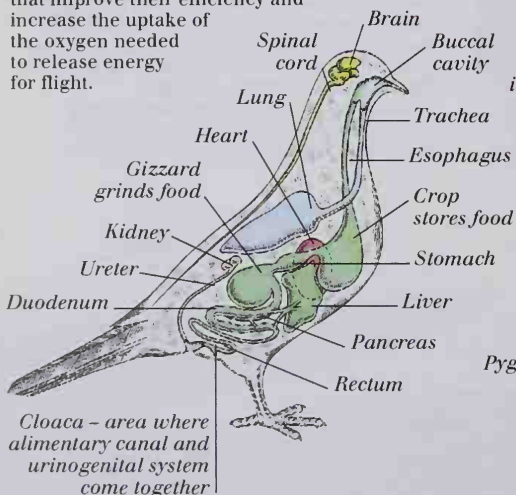

BEAK ADAPTATIONS

A bird's beak consists of two bony jaws covered by a layer of the structural protein keratin. Birds use their beaks to build nests, to preen, and to gather and hold food before it is swallowed. Beak shapes and sizes are highly specialized, varying enormously according to a bird's diet and its feeding technique.

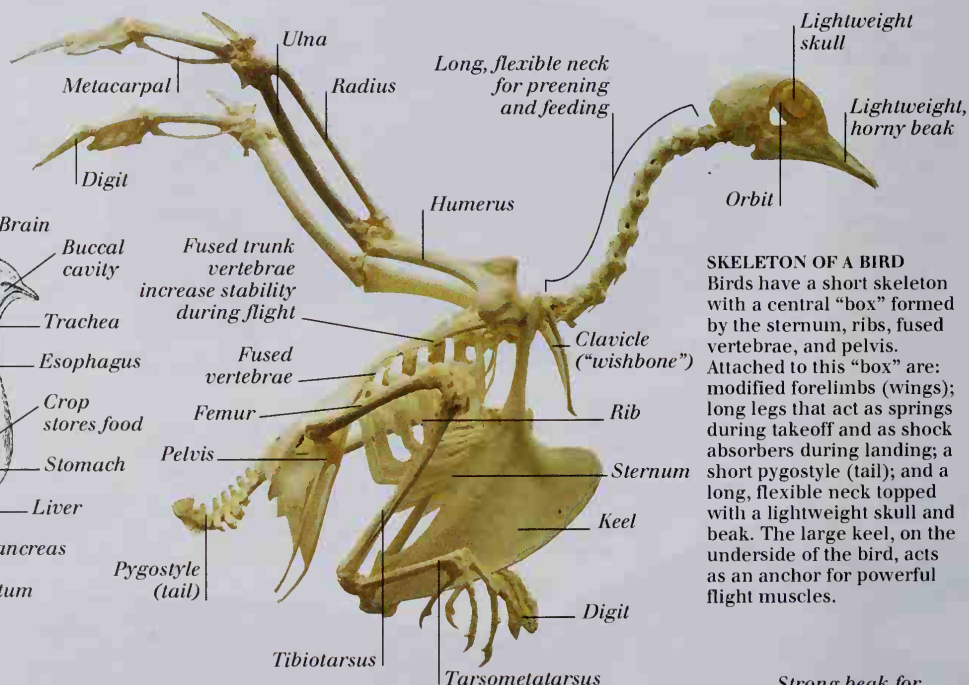

SKELETON OF A BIRD

Birds have a short skeleton with a central "box" formed by the sternum, ribs, fused vertebrae, and pelvis. Attached to this "box" are: modified forelimbs (wings); long legs that act as springs during takeoff and as shock absorbers during landing; a short pygostyle (tail); and a long, flexible neck topped with a lightweight skull and beak. The large keel, on the underside of the bird, acts as an anchor for powerful flight muscles.

Fringes on either side of the bill sift water and trap small animals and plants



FLAMINGO BEAK

Serrated beak for catching fish



MERGANSER BEAK

Strong, hooked beak for tearing flesh



FALCON BEAK

Strong beak for cracking nuts and hook for tearing fruit



PARROT BEAK

HOW A BIRD FLIES

A bird's wing has an airfoil shape – a convex upper surface and concave lower surface – which naturally generates lift when air flows over it. Propulsion occurs when the wings are pulled up and down by separate sets of muscles. During the downstroke, the wing

twists to push down and back, creating forward propulsion and lift. During the upstroke, the feathers separate to let air through and the wing twists in the opposite direction, fanning backward to create further propulsion.

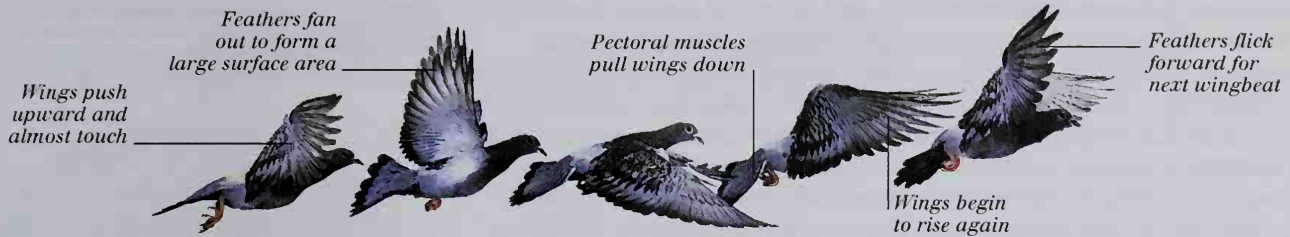

FLIGHTLESS BIRDS

Over millions of years, some bird species, such as the ratites and penguins, have lost the power of flight. Their wings have become smaller and in some cases, have adapted to perform other functions. Penguins, for example, use their flipperlike wings to swim rapidly underwater in search of food. The ratites, including emu, ostrich, rhea, and kiwi, have relatively small wings that lack flight feathers, no keel, and long legs that enable them to run quickly to escape predators.

WADING BIRDS

Wading birds, which include herons, ibises, oystercatchers, snipes, and avocets, are well adapted for life on the edges of rivers, lakes, estuaries, and the sea. They have long, thin legs that enable them to wade through the water in search of food. The beaks of wading birds vary according to their feeding method and prey. Avocets, for example, sweep their narrow, upturned beaks from side to side through the water, in search of tiny animals.

EXAMPLES OF BIRD TYPES

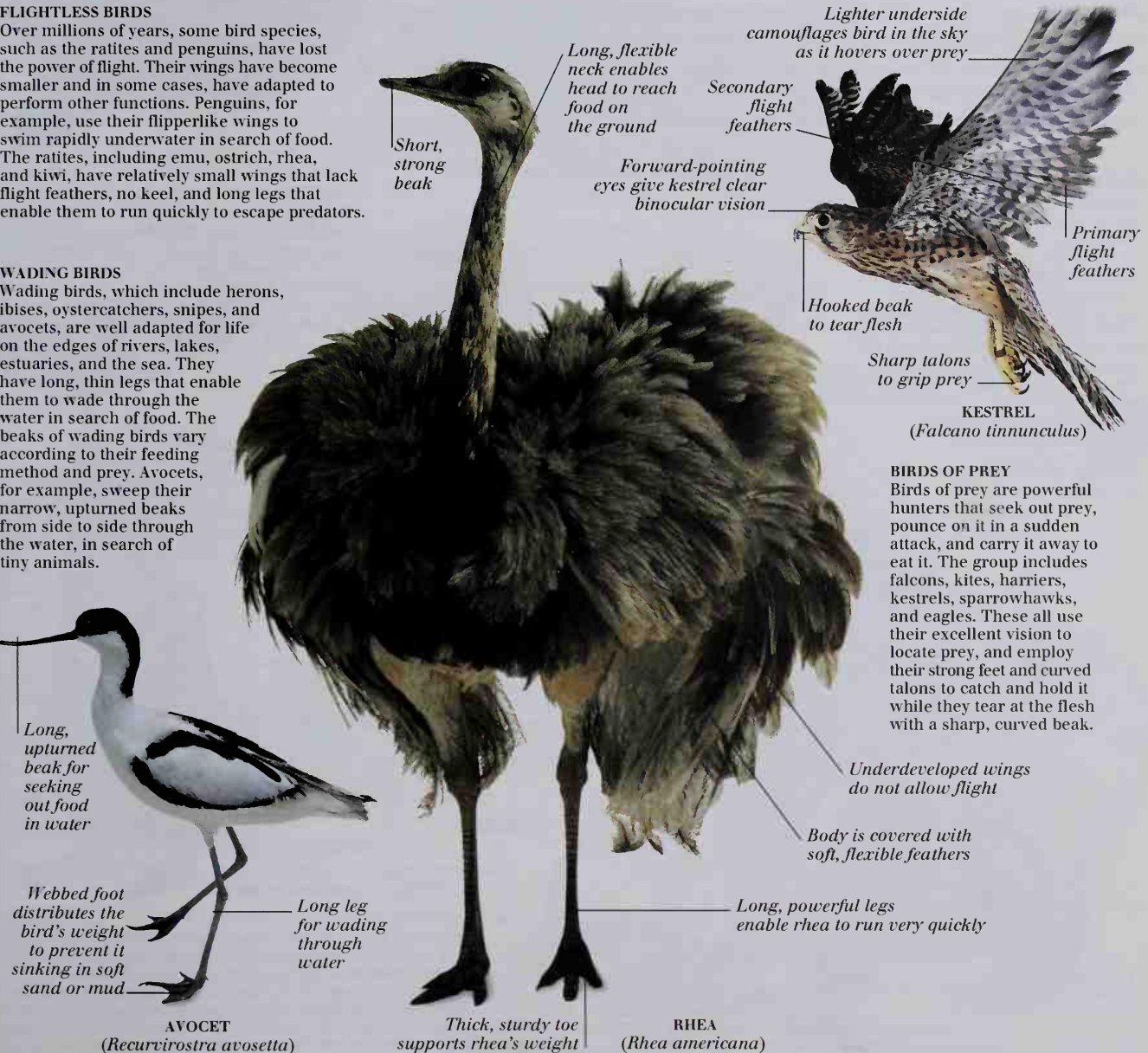

Short, strong beak

Long, flexible neck enables head to reach food on the ground

Lighter underside camouflages bird in the sky as it hovers over prey

Secondary flight feathers

Forward-pointing eyes give kestrel clear binocular vision

Primary flight feathers

Hooked beak to tear flesh

Sharp talons to grip prey

KESTREL
(*Falco tinnunculus*)

BIRDS OF PREY

Birds of prey are powerful hunters that seek out prey, pounce on it in a sudden attack, and carry it away to eat it. The group includes falcons, kites, harriers, kestrels, sparrowhawks, and eagles. These all use their excellent vision to locate prey, and employ their strong feet and curved talons to catch and hold it while they tear at the flesh with a sharp, curved beak.

Underdeveloped wings do not allow flight

Body is covered with soft, flexible feathers

Long, powerful legs enable rhea to run very quickly

Thick, sturdy toe supports rhea's weight

RHEA
(*Rhea americana*)

AVOCET
(*Recurvirostra avosetta*)

Mammals

MAMMALS FORM A DIVERSE GROUP of vertebrates, which includes bats, elephants, baboons, whales, rabbits, and tigers. All female mammals produce milk with which they feed their young. This is formed in modified skin glands, called mammary glands, and plays a key role in parental care. As mammals are endothermic, most have a covering of fur or hair that helps insulate their bodies. They also have dentition that is adapted to coping with their diet. Mammals are divided into three groups according to the way they reproduce. Monotremes, found in Australasia, lay soft-shelled eggs from which young hatch. The other two groups give birth to live young. Marsupials, found in the Americas and Australasia, give birth to tiny, undeveloped young, which make their way to an abdominal pouch where they attach themselves to a nipple and continue their development. The largest group is the placental mammals. Their young develop inside the mother's uterus and are nourished through an organ called the placenta.

SUCKLING

Suckling is unique to mammals and is an essential part of parental care. Female mammals produce milk in mammary glands and release it through their nipples. After birth, newborn mammals instinctively seek out a nipple. Milk is released in response to the infant's sucking action. As they grow older, mammals are weaned onto solid food.



SKELETON OF A MAMMAL

Mammals have a bony endoskeleton typical of tetrapods (four-limbed vertebrates). A backbone forms the main body axis; an anterior skull houses the brain and sense organs; and ribs surround the thorax. Considerable variations do occur, especially in the limbs. For example, monkeys and apes have long arms and hands for climbing; the forelimbs of seals are modified as flippers for swimming; fast-running horses have slender legs that end in a hoof; and moles have short, strong, spadelike forelimbs for digging.

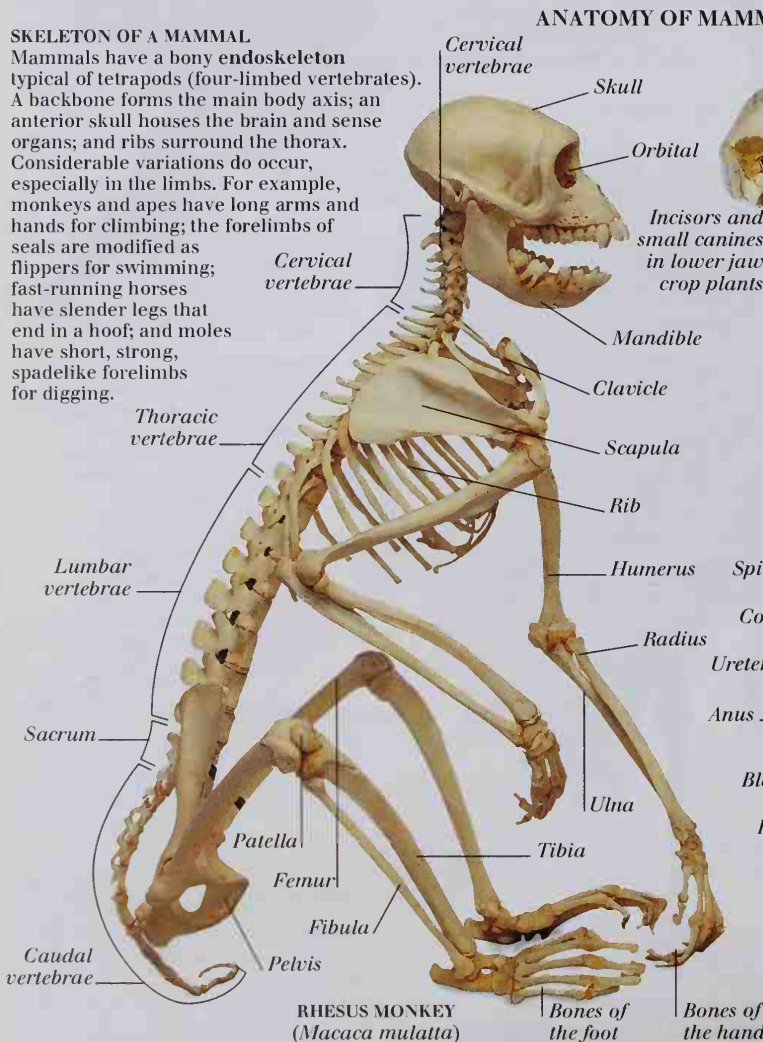

RHESUS MONKEY (*Macaca mulatta*)

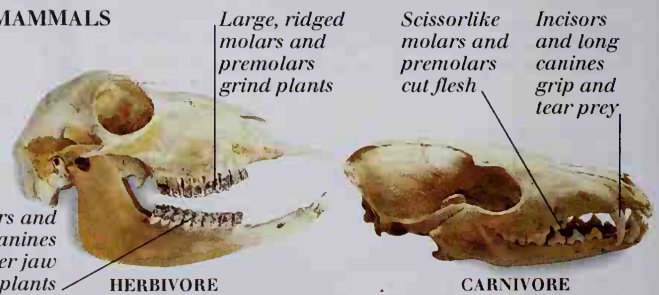

MAMMAL DENTITION

The number, shape, and arrangement of teeth in a mammal's mouth are related to diet and lifestyle. Herbivores, such as sheep, have teeth adapted to cropping plants and grinding up vegetation. Carnivores, such as dogs, have teeth adapted to gripping, tearing, and cutting up flesh.

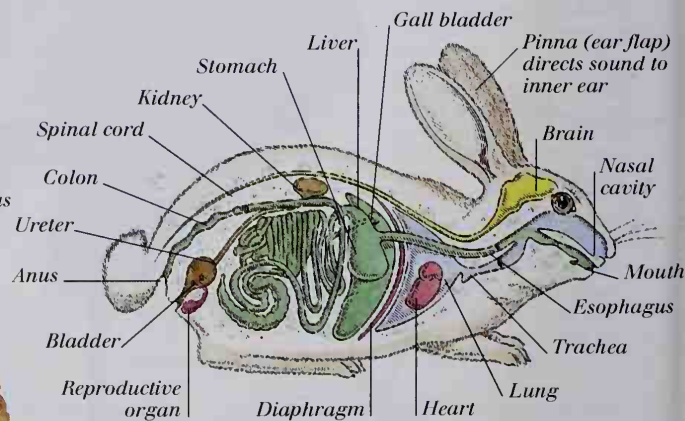

INTERNAL FEATURES OF MAMMALS

Mammals have a relatively large brain, a dorsal spinal cord, and an extensive nervous system. A four-chambered heart pumps blood around the circulatory system and paired kidneys excrete metabolic waste as urea in watery urine. The thorax and abdomen are separated by the diaphragm, a sheet of muscle found only in mammals, which contracts to help draw air into the lungs during breathing.

HOW CHEETAHS RUN

Over short distances, cheetahs can reach speeds of up to 100 kilometers per hour. Their hind legs push off together, providing the main propulsive thrust. Nonretractable claws act like running spikes

to increase grip. Cheetahs also have a streamlined body and a highly flexible backbone. As the backbone extends and flexes, it increases the stride length and overall speed.



TYPES OF MAMMALS



PLACENTAL MAMMALS: FLYING MAMMALS
Bats (order Chiroptera) are the only mammals capable of powered flight. Their forelimbs are modified as wings; a flap of skin is stretched over elongated finger bones. There are two groups of bats: fruit bats, which use their large eyes to find food, such as fruit and nectar; and insect-eating bats, which use echolocation.



PLACENTAL MAMMALS: SEA MAMMALS
There are three groups of sea mammals: whales and dolphins (order Cetacea) and dugongs and manatees (order Sirenia), which spend their entire life in water; and seals and walrus (order Pinnipedia), which come ashore in order to breed.



MARSUPIALS
Marsupials, or pouched mammals (order Marsupialia), show considerable diversity in shape, lifestyle, and habitat. They include grazing kangaroos and wallabies, tree-living koalas, omnivorous opossums, burrowing wombats, the marsupial mole, and the carnivorous Tasmanian devil.



MONOTREMES
There are three species of monotreme or egg-laying mammals (order Monotremata): the platypus and two species of echidnas. The platypus is semi-aquatic, swimming in streams and rivers. Echidnas are armed with spines and use their snout and long tongue to feed on ants.



PLACENTAL MAMMALS: PRIMATES
Primates (order Primates) include lemurs, tarsiers, monkeys, apes, and humans. Most are tree-dwelling, but some, such as this gorilla, are adapted for life on the ground. Primates typically have grasping hands and feet with long digits for climbing and manipulating objects.

Ecology

ECOLOGY IS THE STUDY of the relationship between living **organisms** and their **environment**. It is studied by scientists called **ecologists**, who analyze interrelationships such as **energy flow** and **food webs** (see pp. 170-171), and **nutrient recycling** (see pp. 172-173). In the same area or habitat, different species form a **community**; the community, together with its surroundings, such as **vegetation**, **temperature**, or **soil type**, forms an **ecosystem**. This can range in size, complexity, and **species diversity**, from a puddle to an ocean. In any ecosystem, individuals compete for resources, and there is a limit to the resources available to each species. This is described as the **carrying capacity** – the maximum size of population for which the ecosystem can provide resources. Different species in an ecosystem interact by, for example, competing for food or shelter, or by having a **predator** and prey relationship. Two species may also have a **symbiotic** relationship, such as **mutualism**, **commensalism**, or **parasitism**, from which one or both benefits.

GEOGRAPHICAL LIFE ZONES

Life zones, or biomes, are geographical areas of the world that have particular physical and climatic characters and distinctive vegetation and animal life. Biomes are essentially large ecosystems. The same biomes can appear in different continents; for example tropical rainforests occur in both South America and West Africa. They have life forms that appear similar because they are adapted to the same environmental conditions.

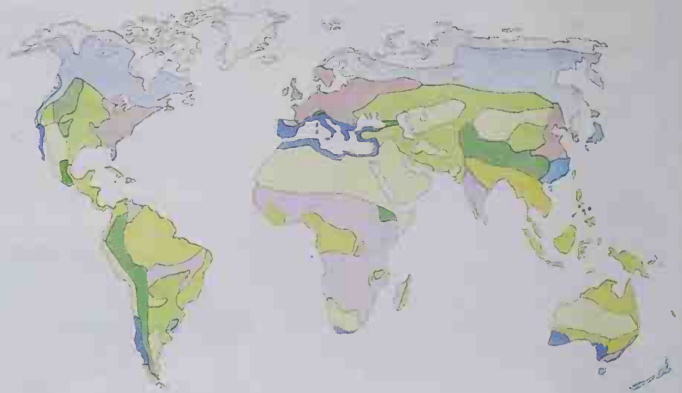

KEY

Tundra	Temperate forest	Savanna	Temperate grassland	Temperate rainforest
Boreal forest	Desert	Tropical rainforest	Mountain	Scrubland

HIERARCHY OF COMPLEXITY

The hierarchy of complexity describes the different levels of relationships between living organisms and their environment. At the base of the hierarchy are individual organisms. Organisms of the same species form a population, and populations that live in the same area

form a community. An ecosystem, such as a pond or a woodland, is made up of a community and its surroundings – both living and non-living. The biosphere is the sum total of all Earth's ecosystems, and includes oceans, land, inland water, and the lower atmosphere.

Biosphere – all regions of the world inhabited by living organisms

Ecosystem – a community and its surroundings

Population – a group of individuals of the same species

Individual – an animal or plant

Biome – ecosystems in the same geographical and climatic zone

Community – populations that exist together in the same area

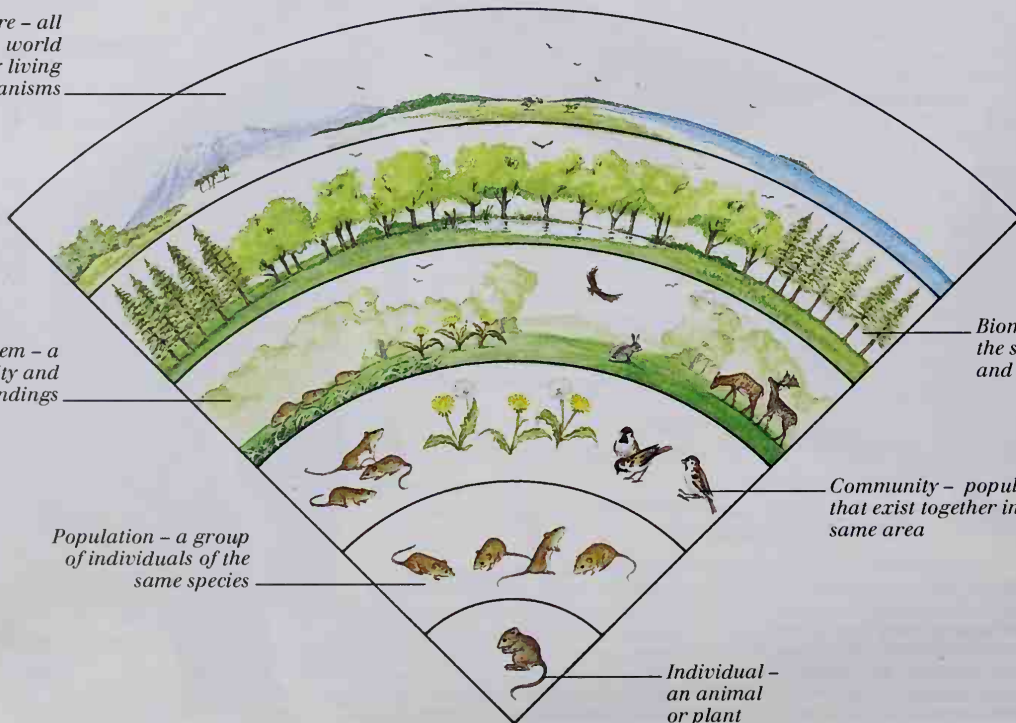

REPRODUCTIVE STRATEGIES



Baby elephants are born in an advanced state of maturity

K STRATEGY

K is a measure of the carrying capacity of a species. K strategists are organisms that are long-lived, reproduce slowly, and produce only a small number of offspring. A population of K strategists tends to remain close to the carrying capacity for its ecosystem. Elephants are K strategists that produce one offspring at a time in an advanced state of development. They nurture the offspring to increase its chances of survival.

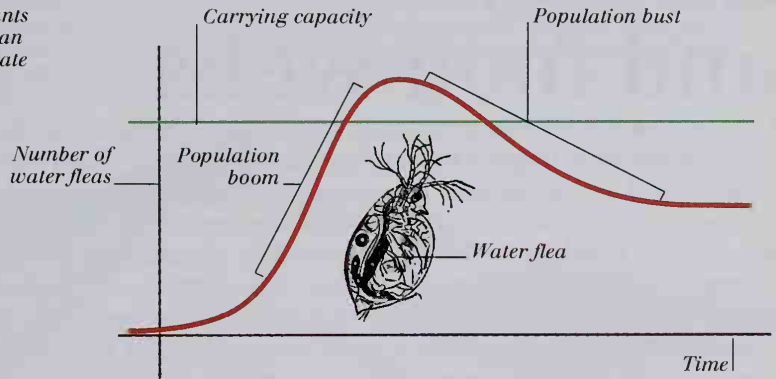

r STRATEGY

r is a measure of population growth speed. r strategists, such as water fleas, are organisms that exploit available resources by reproducing as quickly as possible. They are usually small, short-lived, and invest energy in reproducing frequently and prolifically. Populations can increase rapidly (boom) or decrease dramatically (bust) if environmental conditions change. The r strategy enables populations to recover quickly.

SPECIES INTERACTIONS



Threadlike stem of dodder twined around stem of host plant

DODDER
(*Cuscuta europaea*)

COMMENSALISM

Commensalism is a form of interaction where one species benefits while the other remains unaffected by the relationship. Clownfish, for example, are small reef fish that seek protection from predators by sheltering among the poisonous tentacles of sea anemones; a mucus covering protects the clownfish from the anemone's stings.



Cleaner wrasse picks parasites from the mouth of the sweetlip

MUTUALISM

Mutualism is a relationship where both species benefit. In the case of the sweetlip fish and the cleaner wrasse, the sweetlip remains motionless while the wrasse picks off irritating parasites from its skin, mouth, and gills. Thus the sweetlip loses its parasites and the wrasse gets food.

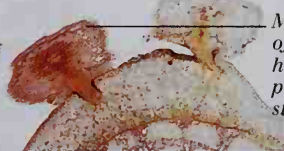

Micrograph of dodder haustorium penetrating stem of host

PARASITISM

Parasitism is a relationship in which one species, the parasite, benefits at the expense of the other, the host. Dodder, for example, is a parasitic flowering plant that wraps around a host plant and forms specialized absorptive organs, called haustoria, which penetrate the host's stem and extract nutrients.



Sea anemone

Clownfish

Energy flow and food webs

LIFE ON EARTH DEPENDS ON A CONSTANT input of energy from the Sun. Sunlight energy is trapped by **autotrophs** (producers), which use it to produce food for themselves. The trapped energy is passed to **herbivorous** animals (primary consumers), which eat the producers. They, in turn, are eaten by **carnivorous** animals (secondary consumers), which are themselves eaten by tertiary consumers. This pathway is called a food chain. The position each species occupies within the food chain is called a trophic (feeding) level. At each level, energy is stored as biomass, the mass of living plants or animals. Much energy is used for maintaining the organism or is lost into the environment as heat. This means that only a small percentage of the energy taken in by one trophic level is available to the next. An ecosystem, such as a woodland or coastline, can contain thousands of different species, many of which are involved in different food chains. These interconnect to form a complex food web.

THE TROPHIC PYRAMID

The trophic pyramid reflects the loss of energy that occurs at each trophic level as energy flows through an ecosystem. The area of each section of the pyramid is proportional to the biomass in each trophic level – it also represents the amount of potential energy available to the next level. As only about 10 percent of the energy in each level is taken up by the level above, each level supports less biomass and fewer individuals. Because of the energy lost, the maximum number of trophic levels that can be supported in a food chain is limited to six. The trophic pyramid shown at right relates to a food chain found in a deciduous woodland.

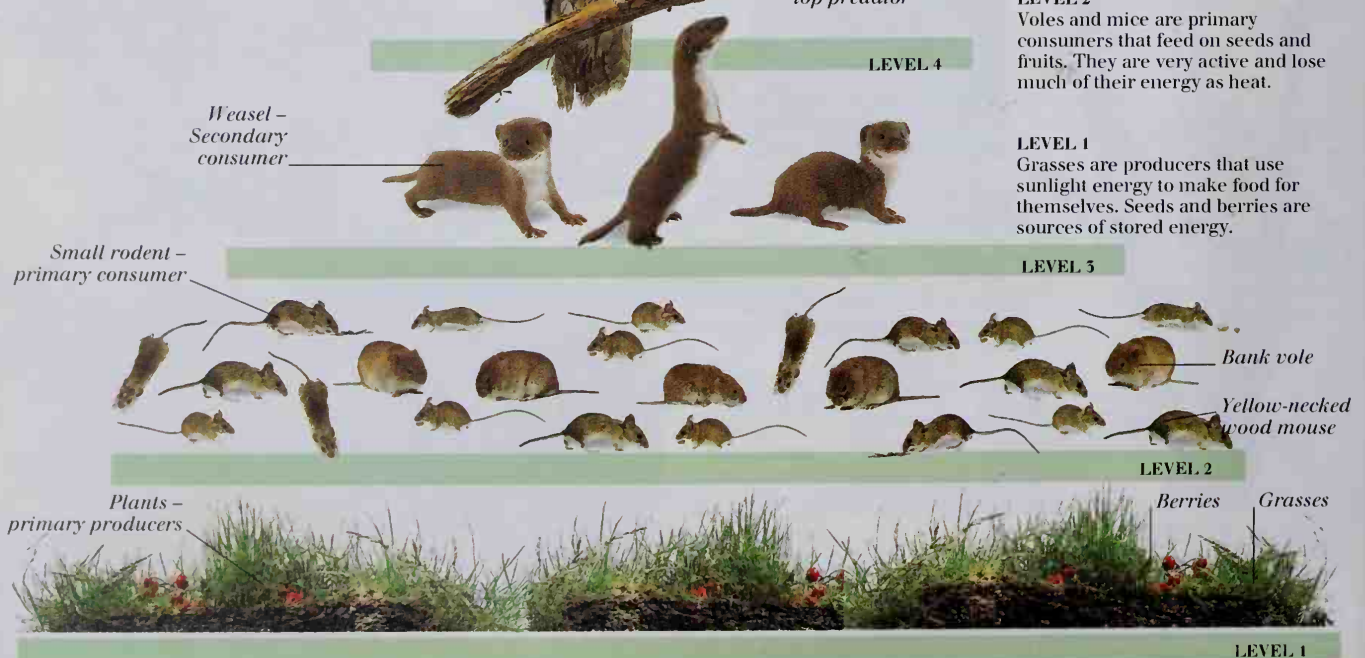

MEASURING ENERGY

The amount of energy contained in a trophic level can be measured using a bomb calorimeter. An organism is weighed and then burned rapidly in a combustion chamber. The energy stored within the organism is converted to heat energy, which can be measured. This is then multiplied by the estimated mass or numbers of all the organisms in the trophic level to give its total energy content.

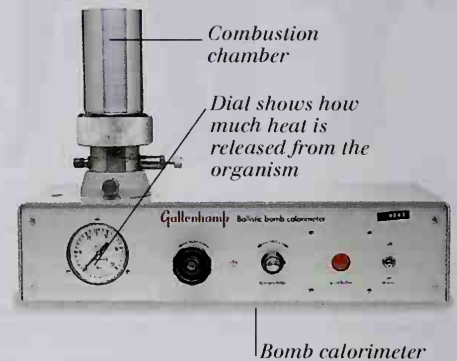

COASTAL FOOD WEB

The food web below shows the feeding relationships among species that live in the sea in coastal waters. It indicates how energy enters and flows through this particular ecosystem. At the "base" of the food web are autotrophic organisms – seaweeds and phytoplankton – which use simple raw materials and sunlight energy to produce energy-rich organic compounds by photosynthesis (see pp. 148-149). The food energy they produce is passed on within a series of food chains. In

each food chain the direction of the arrows indicates which species is being eaten by which, and also the direction of energy flow. Because in an ecosystem, each species is involved in different food chains, they become interconnected to form an intricate food web, within which animals may feed at different trophic levels. This coastal food web is highly simplified and shows only a few of the interlinked food chains and species involved.

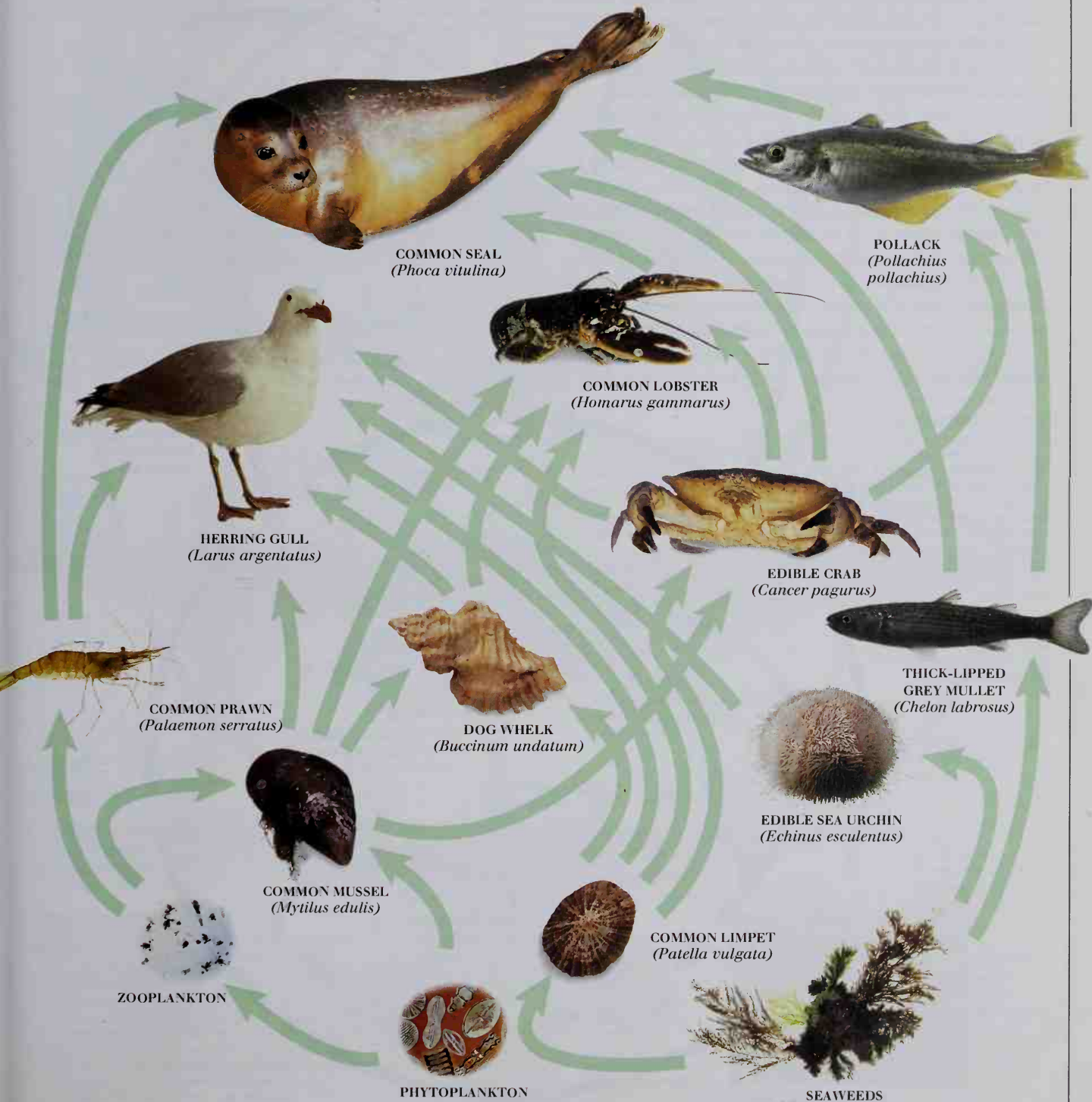

Natural cycles

CARBON, NITROGEN, OXYGEN, WATER, and other raw materials that make up living organisms are continually recycled between the living and nonliving parts of the biosphere; energy from the Sun drives these natural cycles. All life is based on complex organic molecules that have a "skeleton" of carbon atoms. These are synthesized during photosynthesis, using carbon dioxide, water, and sunlight energy, and are passed to animals when they eat plants. Carbon dioxide is returned to the atmosphere when carbohydrates are broken down during respiration. Oxygen is released during photosynthesis and is used during respiration. Nitrogen is taken in by plants as nitrates and added to the carbon skeleton to form proteins, DNA, and other essential compounds. When organisms die, the complex molecules from which they are made are broken down by decomposing organisms to yield simple substances that can be reused. Water forms a large part of all organisms and is constantly being lost and recycled.

THE WATER CYCLE

Wind and the heat of the Sun cause water molecules to evaporate from the surface of oceans and lakes, from soil, and from living organisms. The water vapor formed rises, cools, and condenses to form water droplets, which collect as clouds. As clouds rise and move into cooler air, they become saturated with water droplets which fall as rain or snow, soaking into the soil and running into lakes, rivers, and oceans.

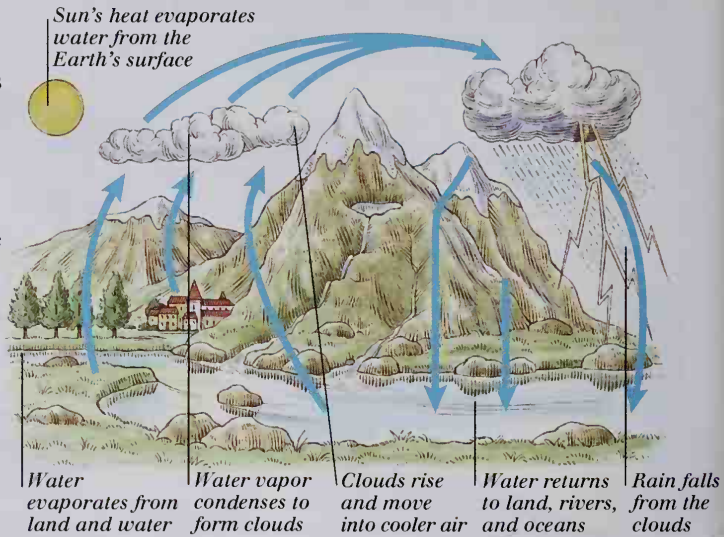

THE NITROGEN CYCLE

Nitrogen-fixing bacteria absorb nitrogen and combine it with oxygen to form nitrates, which can be absorbed by plants. Nitrogen is also fixed by lightning. Animals obtain nitrogen by eating plants. Decaying dead animals and plants release nitrogenous compounds, which are then converted by nitrifying bacteria to nitrates. These are absorbed by plants through their roots. Denitrifying bacteria also break down nitrates released from dead animals and plants and release nitrogen back into the atmosphere.

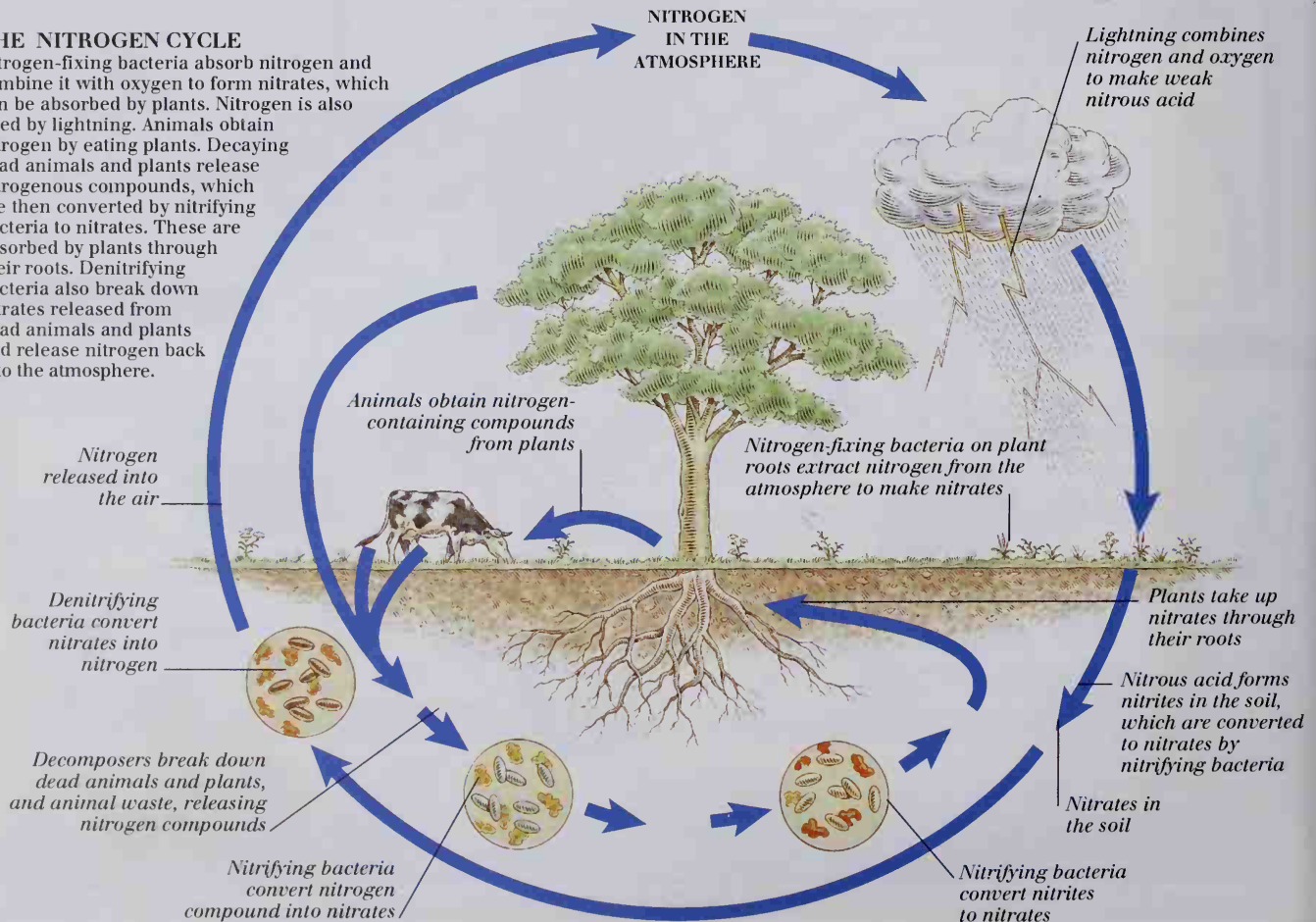

THE CARBON CYCLE

Green plants and some bacteria use carbon dioxide as a raw material in photosynthesis to make organic, carbon-containing compounds, such as carbohydrates, which are eaten by animals. Both animals and plants use carbohydrates in respiration and release waste carbon dioxide into the atmosphere. During the day, the amount of carbon dioxide consumed by plants for photosynthesis is greater than that released from respiration; at night, however, the reverse is true.

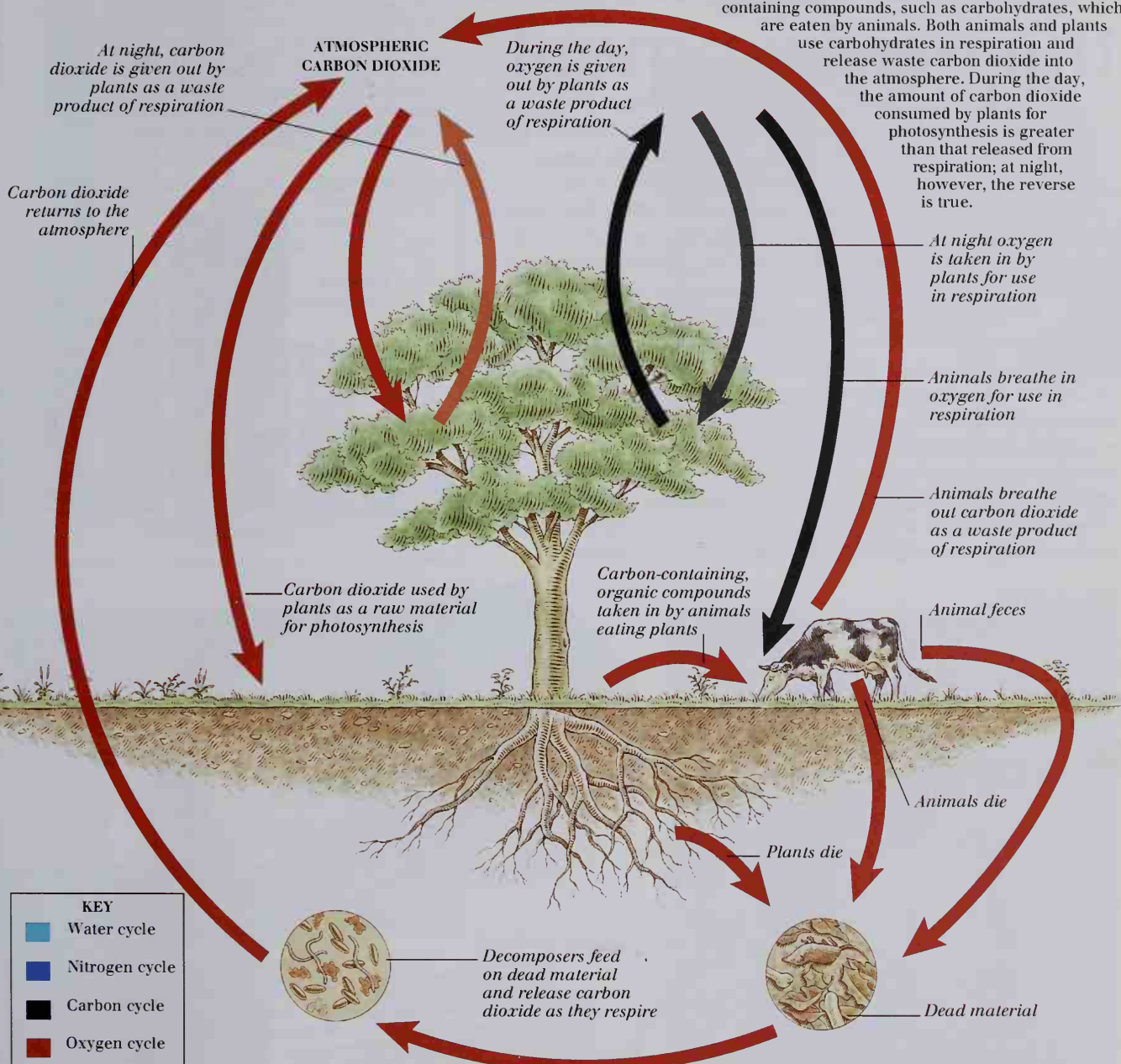

THE OXYGEN CYCLE

Animals and plants take in oxygen and use it to release energy from carbohydrates through aerobic respiration (see pp. 124-125). During the day, when sunlight energy is available, plants release oxygen as a waste product of photosynthesis. The amount of oxygen released by day from photosynthesis far exceeds oxygen consumed by the plant for respiration. At night, there is a net intake of oxygen as photosynthesis ceases but respiration continues.

DECOMPOSITION

When a living organism dies, its constituent organic compounds are broken down into simple raw materials by organisms called decomposers. During this process, carbon dioxide, nitrates, phosphates, and other essential nutrients are released. Large decomposers (detritivores), such as earthworms, break down larger pieces of dead material so that fungi and bacteria can complete the process of decomposition.



Flies lay eggs

Maggots hatch and feed on dead shrew

Human impact on the environment

HUMAN BEINGS HAVE HAD A GREATER IMPACT on the environment than any other species in the Earth's history. The main reason for this has been the huge increase in human population, from 2.5 billion in 1950 to over 5 billion in the 1980s, and it is estimated to reach 8.5 billion by 2025. The rising population has required more space for towns and cities and more land to produce food. The resulting **habitat** destruction has led to the **extinction** of many species and a decrease in the Earth's **biodiversity**. Modern manufacturing methods, transportation systems, and intensive agriculture consume vast amounts of energy and often nonrenewable natural resources. This frequently causes pollution, which has reduced biodiversity, affected human health, and caused global warming. Ecologists have monitored the changes to ecosystems caused by human impact. Such monitoring may indicate the need to slow or reverse the damage caused by conserving habitats and endangered species, cutting pollution, and reducing consumption of nonrenewable resources.

POLLUTION

Pollution is the release, by humans, of agents that upset the natural balance of the living world. Vast quantities of pollutants, such as garbage, sewage, chemical waste, pesticides, and waste gases from vehicle exhausts and power plant emissions, are released every day. Pollution is now seriously affecting the environment by introducing synthetic and potentially poisonous chemicals in huge quantities.

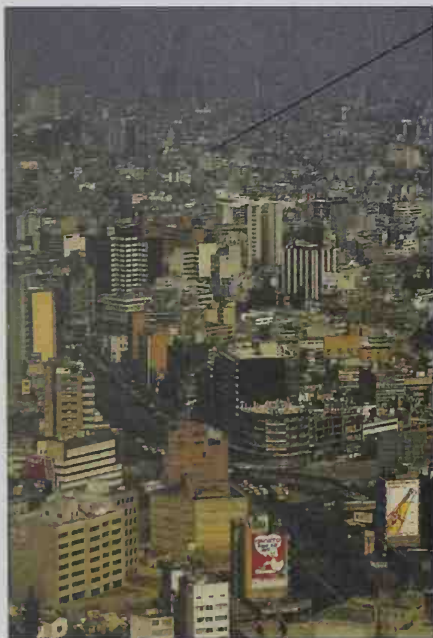

MEXICO CITY, MEXICO

Smog is produced mainly by vehicle exhaust fumes



OZONE LAYER

The ozone layer screens out harmful ultraviolet rays from the Sun. As a result of damage from atmospheric pollutants, particularly CFCs (chlorofluorocarbons), holes in the ozone layer appear annually over Antarctica, and the layer is also thinning elsewhere.

False-color photograph taken from space shows ozone levels

Ozone "hole" over Antarctica

Acid rain removes vital minerals from soil



Conifers dying

Acid water runs off into lakes and rivers

ACID RAIN

The burning of fossil fuels releases nitrogen and sulfur oxides into the air. These combine with water vapor in the atmosphere to form acidic droplets that fall to Earth as acid rain. This damages trees, erodes and defaces buildings, and lowers the pH of lakes, killing fish.

Fish dying as a result of water pollution



WATER POLLUTION

Rivers, ponds, and lakes can be polluted by chemicals from industry and agriculture. Acid rain, chemical spills, and agricultural pesticides poison fish and other aquatic organisms. Fertilizers are washed into lakes where they encourage algal growth; this depletes oxygen levels and "suffocates" aquatic animals.

HOW GLOBAL WARMING OCCURS

The Sun's rays are reflected from the Earth's surface into space. Gases in the atmosphere, particularly carbon dioxide, act like greenhouse glass, trapping some of the Sun's heat energy. This "greenhouse effect" naturally warms the Earth enough to sustain life. This century, carbon dioxide levels have risen due to increased burning of fossil fuels. This has led to global warming – the retention of extra heat by the atmosphere and a rise in the Earth's average temperature.

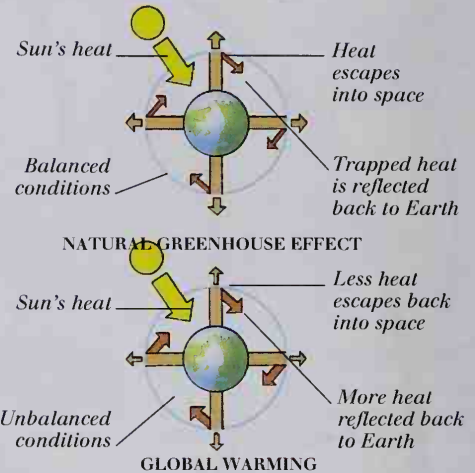

THREATS TO WILDLIFE

ENDANGERED SPECIES

During evolution, species naturally become extinct. However, in recent centuries the rate of extinction has accelerated enormously due to human pressures, such as pollution, loss of habitat, hunting, and the introduction of alien species. The numbers of endangered species are monitored by the World Conservation Union (IUCN – International Union for the Conservation of Nature). This chart shows the relative proportions of endangered species, in different animal groups, that are recorded in the IUCN's Red Data Book.

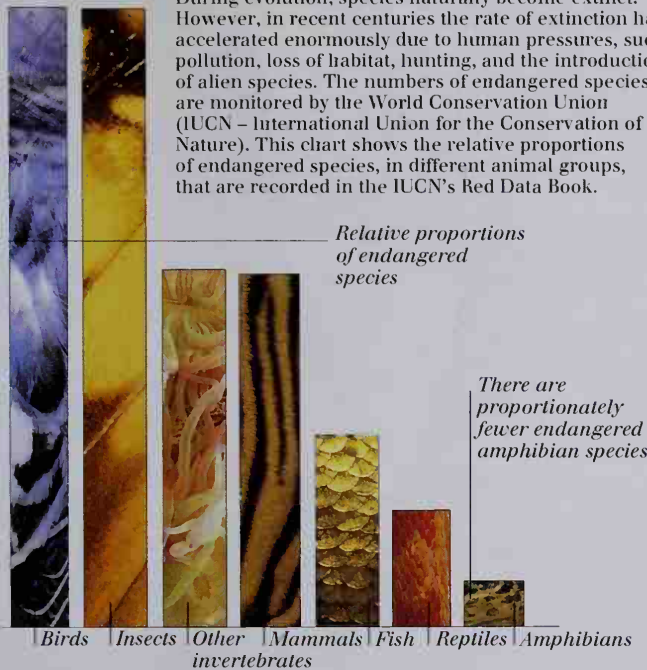

Paratoid gland produces toxic secretions

Cane toad can grow up to 24cm in length



CANE TOAD
(*Bufo marinus*)

INTRODUCED SPECIES

In 1935, the cane toad was introduced from South America to Queensland, Australia, in order to eat the cane beetle, which was destroying the sugar-cane crop. This large toad ate not only cane beetles but also many native invertebrates and vertebrates, some of which are now threatened with extinction. The cane toad population has increased rapidly, as it has no natural predators due to the toxic secretions it produces, which kill its attackers.

MONITORING AND CONSERVING LIVING ORGANISMS



The bird is tagged with a loose fitting ring

MARKING AND TAGGING ANIMALS

Marking animals with a tag allows scientists to monitor their movements. The type of tag must be chosen carefully to ensure that it does not interfere with the animal's normal behavior. Birds are tagged, or banded, with a ring on the leg; fish are marked with a tag attached to a fin; and larger mammals have a radio collar that transmits a radio signal.

WILDLIFE RESERVES

Wildlife reserves are areas of habitat that are set aside, protected from human impact, and managed to ensure conservation of their natural populations of animals and plants. Yellowstone Park, seen here, was the world's first national park. Its inhabitants include bison, an animal that was hunted to near extinction in the 19th century by European settlers. Bison have since prospered in this protected area.



American bison in Yellowstone National Park, Wyoming

Number of organisms are recorded

Scientist sampling species distribution on the seabed

Quadrat

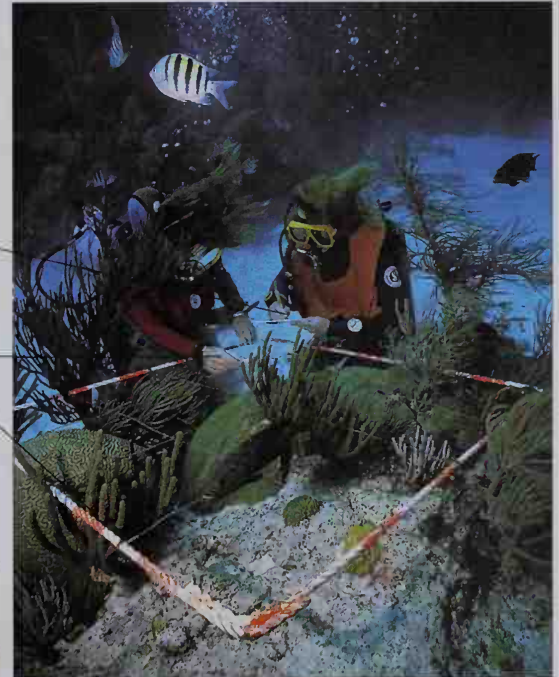

SAMPLING THE ENVIRONMENT

It is impossible to count all the organisms in an area, but by taking samples, the numbers and distribution of species can be calculated. One method is to use a quadrat, a square frame of known area, within which the numbers of members of species are counted. Random placement of quadrats allows scientists to look for changes in patterns of distribution.



Lateral and posterior views of the head and neck

HUMAN ANATOMY

DISCOVERING HUMAN ANATOMY	178
BODY AREAS	180
SKELETON	182
MUSCLES	184
BRAIN, SPINAL CORD, AND NERVES	186
ENDOCRINE SYSTEM	188
HEART AND BLOOD VESSELS	190
LYMPHATIC SYSTEM	192
RESPIRATORY ORGANS	194
DIGESTIVE ORGANS	196
URINARY AND REPRODUCTIVE SYSTEMS	198
HEAD AND NECK 1	200
HEAD AND NECK 2	202
HEAD AND NECK 3	204
HEAD AND NECK 4	206
TRUNK 1	208
TRUNK 2	210
THORAX 1	212
THORAX 2	214
ABDOMEN 1	216
ABDOMEN 2	218
ABDOMEN 3	220
PELVIC REGION 1	222
PELVIC REGION 2	224
SHOULDER AND UPPER ARM	226
FOREARM AND HAND	228
THIGH	230
LOWER LEG AND FOOT	232



Discovering human anatomy

THE STUDY OF HUMAN ANATOMY is closely related to physiology and to medical science. Physiology is the study of how the body works, and medical science is concerned with keeping the body healthy. Since the restrictions on dissection of human bodies were lifted by the 16th century, progress in the field of anatomical research has been rapid, and modern anatomists now have a detailed understanding of the human body.

ANCIENT IDEAS

Members of early civilizations had very little experience of the internal organs of the human body, glimpsing them only when people were badly injured. Crude surgery also provided opportunities for acquiring a working knowledge of the body. Embalmers of ancient Egypt removed the organs of dead bodies while making mummies, but this was done for religious rather than scientific reasons. The human skeleton, however, was well known to the ancients, because it remains intact after death.

THE INFLUENCE OF GALEN

The quest of the ancient Greek philosophers to understand the world around them included attempts to comprehend the human body. As in other civilizations, dissection of a human being was illegal in ancient Greece. The greatest contributions to anatomy during this time were made by **Galen**. Galen performed dissection on animals and made many precise observations. During such dissections, he observed the valves in the heart, identified several nerves in the head (cranial nerves), and described muscles and bones with great accuracy. In experiments on living animals (vivisection), he demonstrated the functions of nerves in several parts of the body, by observing the effect of tying them off, or by slicing through the spinal chord between different vertebrae. He also showed that arteries carry blood, not air as had been taught previously. However, Galen made as many wrong guesses as he did accurate observations. He considered, for example, that flesh formed from blood. After Galen,

almost all anatomical research ceased until the 15th century, and until then all his ideas were accepted as correct.

THE RENAISSANCE

During the 15th and 16th centuries, restrictions on human dissection were lifted. It was then that many of the experiments that Galen described were first reproduced, and some of his claims about the human body were at last shown to be false. During this time, most artists studied anatomy to help them draw the human body. For example, the Italian artist **Leonardo da Vinci** is famous for his remarkably accurate drawings of the human body, including drawings of fetuses developing in the womb. Leonardo carried out several dissections himself, but his anatomical work remained unknown until long after

his death. Interest in human anatomy was focused on Italy, in particular in Padua and Bologna. It was at Padua that a brilliant anatomist called **Andreas Vesalius** carried out most of his important work.

Vesalius is known as the founder of modern human anatomy. He was one of the first to deny some of Galen's anatomical studies – he produced far more accurate ones of his own. In 1543, he published *De Humani Corporis Fabrica* (*On the Structure of the Human Body*). This comprehensive work gave details of all the major systems of the human

SETTING BONES

Jointed models were used, from the late 16th century, to teach bonesetting to students of anatomy. This model has joints that correspond to human joints such as the shoulder, elbow, and wrist.



ANATOMICAL MODEL

After restrictions on human dissection were lifted, the study of anatomy spread. Students would often use models such as this one. It is a fairly accurate anatomical model of a woman and includes the uterus (womb), containing a fetus.



body, including the nervous system, reproductive system, and the blood vessels.

THE MICROSCOPE

The invention of the microscope in the 17th century was important in most of the sciences, including human anatomy. The study of anatomy on the microscopic scale is called histology. An important example of the impact of the microscope on human anatomy is the verification of the theory of blood circulation. **William Harvey** formulated the theory in the 1620s. In a set of inspired experiments, he contradicted many of Galen's ideas about blood. Whereas Galen had assumed that blood is manufactured directly from food and then becomes flesh, Harvey correctly realized that blood circulated continuously, out from the heart in arteries and back through veins. The theory had one major problem that prevented it from being widely accepted. No one could find any links between arteries and veins. Without such links, blood could not circulate as Harvey had suggested. In 1661, **Marcello Malpighi** observed tiny blood capillaries under his microscope. These capillaries were the missing link in Harvey's theory. Histology also added to knowledge of muscles and bones. Microscopic observations of muscle fibers led to the classification of the three types of muscle (voluntary, involuntary, and cardiac), and the realization that muscles contract due to the combined shortening of thousands of individual fibers. **Clopton Havers** used the microscope in his important examinations of the inner structure of bones.

18TH AND 19TH CENTURIES

During the 18th century, anatomical studies were becoming more and more detailed. In the 19th century the first comprehensive textbook on histology was published. In physiology, however, many questions remained unanswered. One such question concerned the action of nerves. Toward the end of the 18th century, **Luigi Galvani** made the legs of dead frogs move by applying electrical impulses to them. This work inspired a whole new avenue of research, known as electrophysiology, which led eventually to the modern understanding of nerve impulses. During the 19th century, there were two main advances in the study of physiology. The first was the



INSIDE AN EYE

This model of the human eye shows the different parts that make up this sensitive and complicated organ. Until around AD 1000, it was believed that the eye gave out light, which somehow formed a picture. Anatomical research eventually revealed this to be untrue.

development of the cell theory – the cell is the basic unit of all living things, including human beings. The second was an understanding of the chemical basis of physiology. One of the pioneers in this field was **Claude Bernard**. Among his many important discoveries was the fact that the liver breaks down a compound called glycogen into a sugar called glucose. This reaction helps to regulate the sugar content of the blood. Bernard's discovery made him begin to realize how the body's internal environment remains so nearly constant, a process known as homeostasis.

20TH CENTURY

Perhaps the most important developments in anatomy and physiology during the 20th century are studies of the endocrine system, the immune system, and the brain. The endocrine system distributes hormones, which help to carry out many of the body's vital functions. The term "hormone" was coined in 1905, and the identification and isolation of hormones such as insulin and epinephrine kept many physiologists busy throughout the century. The body's immune response was not understood until the 1950s, when the electron microscope was used to study minute structures within the cell and the structure of viruses. Other technological advances, including magnetic resonance imaging (MRI) and computer-assisted tomography (CAT) have increased understanding of the brain. MRIs and CAT scans of the living brain have helped physiologists to understand how the brain's functions are related to its structure.

TIMELINE OF DISCOVERIES

	500 BC	Alcmaeon of Croton , probably the first person to scientifically dissect human beings, discovers the optic nerves and identifies the brain as the seat of intellect
Empedocles shows that the heart is the center of the body's system of blood vessels	450 BC	
	AD 170	Galen carries out detailed dissections, but works mainly on animals
Mondino de Luzzi publishes the first practical manual of anatomy	1316	
	1545	Andreas Vesalius publishes probably the most important book ever on anatomy, <i>On the Structure of the Human Body</i>
Bartolommeo Eustachio describes many human features in great detail, including the adrenal glands and the Eustachian tubes, named after him	1552	
	1605	Heironymus Fabricius presents a detailed study of the valves in veins
William Harvey announces his idea that blood circulates around the body, with the heart as a pump. The idea is published 12 years later	1616	
	1652	Thomas Bartholin discovers the lymphatic system
Francis Glisson publishes an important study of the liver	1654	
	1658	Jan Swammerdam is the first scientist to observe red blood cells
Marcello Malpighi studies the lungs and the blood capillaries under the microscope	1660	
	1669	Richard Lower shows that blood changes color in the lungs
Clopton Havers produces the first complete textbook of the bones of the human body	1681	
	1772	Italian anatomist Antonio Scarpa , makes an extensive study of the ear, discovering the semicircular canals and the cochlea
William Beaumont studies digestion in the open stomach of a wounded man	1822	
	1850	Charles Bell releases an enlarged version of his 1811 book, <i>The Nervous System of the Human Body</i> , in which he distinguishes between sensory and motor neurones (nerves)
Paul Langerhans discovers the islets of Langerhans, groups of cells that were later shown to produce insulin in the pancreas	1869	
	1875	Camillo Golgi devises a way to stain nervous tissue so that it can be studied under the microscope
William Bayliss and Ernest Starling discover the importance of hormones in the body	1902	

Body areas



HUMAN ANATOMY IS THE STUDY of the structure of the body. This section describes the different parts of the body and how they “fit together” to produce a living human being. The first part (pp. 180-199) describes the various body systems – such as the reproductive system (pp. 198-199) – which each consist of **organs** that work together to perform particular functions. The second part (pp. 200-235) describes the detailed internal structure of the body. The body has been divided into areas: the head and neck

(pp. 200-207); the **thorax** (pp. 212-215), **abdomen** (pp. 216-221), and **pelvic region** (pp. 222-225), which together form the **trunk** (pp. 208-211); the shoulder and upper arm (pp. 226-227); the forearm and hand (pp. 228-229); the thigh (pp. 230-231); and the lower leg and foot (pp. 232-233). Males and females have the same body areas, but their body shapes and reproductive organs differ. The entire body is covered by skin, a waterproof layer that stops the entry of **microorganisms** and acts as a **sense organ**.

ANTERIOR VIEW OF FEMALE

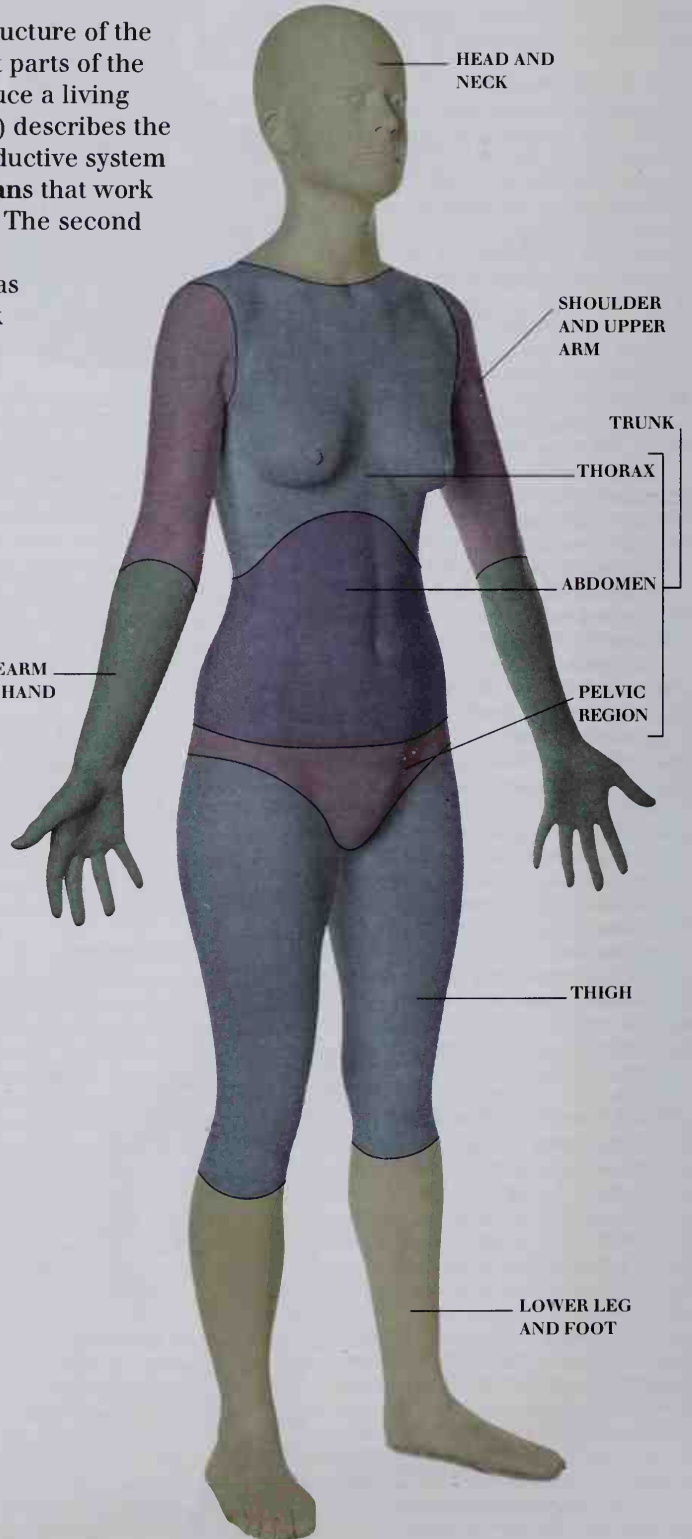

POSTERIOR VIEW OF FEMALE

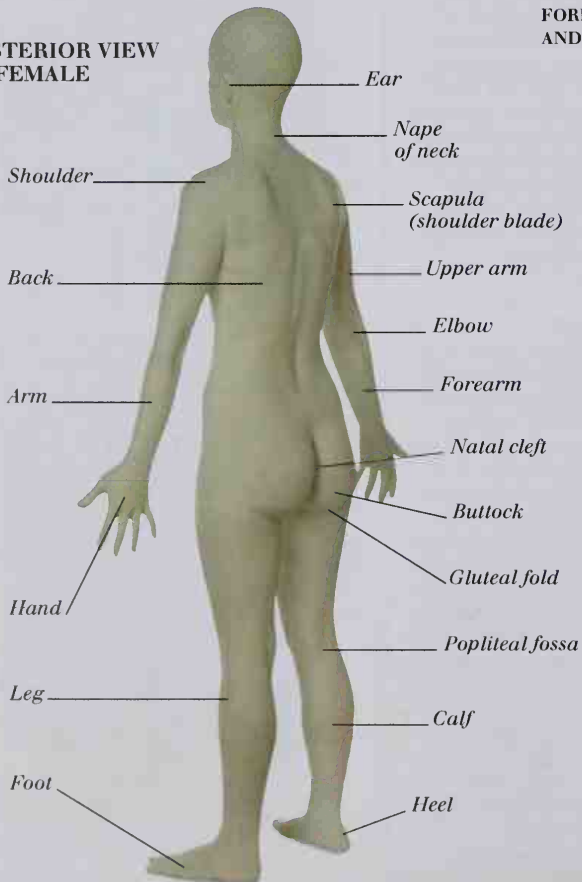

ANTERIOR VIEW OF MALE

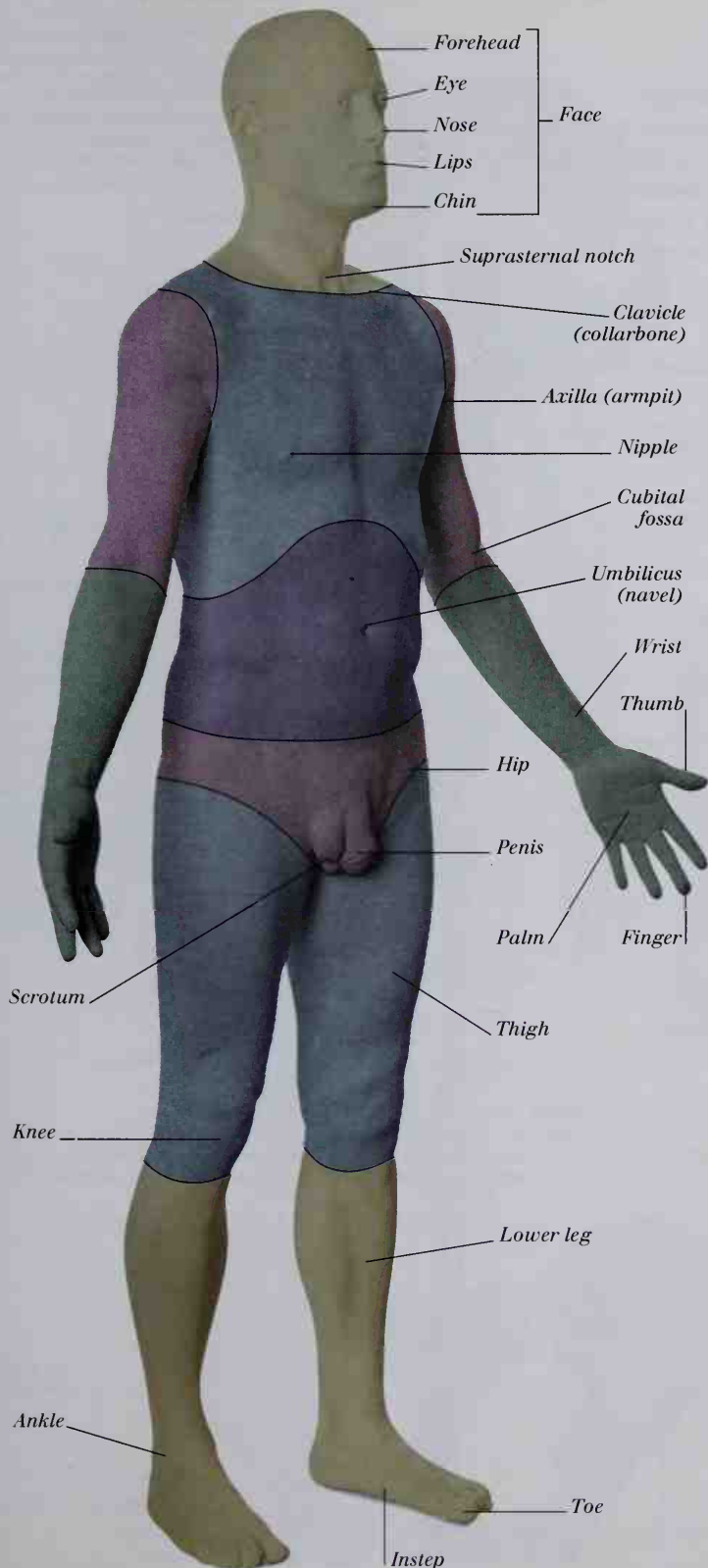

SKIN, HAIR, AND NAILS

DERMIS

Skin consists of two layers, the outer epidermis and the dermis. The dermis contains nerve endings, hair follicles, and oil-producing sebaceous glands.

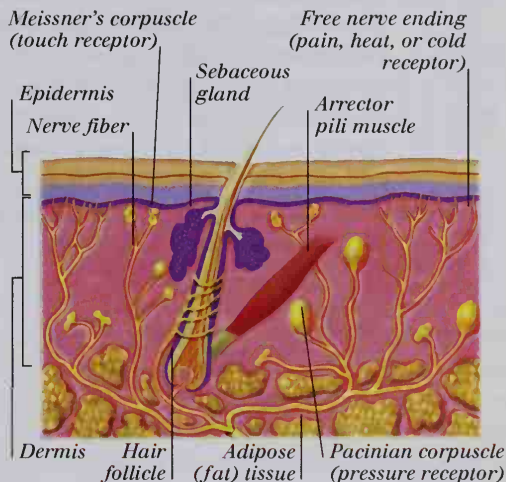

EPIDERMIS

The uppermost of the five epidermal layers consists of tough, flattened cell remnants that protect the lower layers. The upper layer is continually worn away and replaced by cells produced by the basal layer; these flatten and die as they move toward the surface.

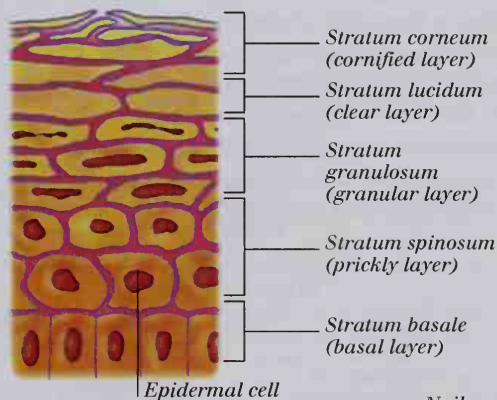

NAIL STRUCTURE

Nails are plates that are derived from the epidermis. They contain keratin to make them hard. Their function is to protect the tips of the fingers and toes and to help the fingers grasp small objects. Nails grow from the matrix, where nail cells divide, lengthening the nail plate by pushing it forward over the nail bed.

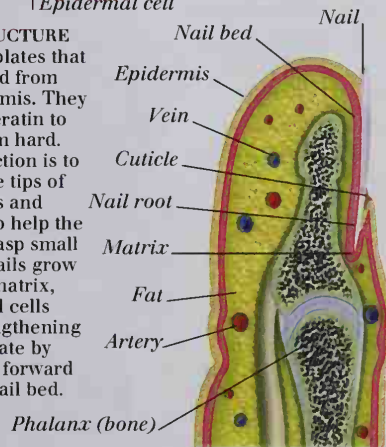

Skeleton



THE SKELETON IS A STRONG but lightweight framework that supports the body, protects the major organs, and enables movement to take place. In adults, it consists of 206 bones, and makes up 20 percent of the body's mass. Bone is a living tissue, supplied by blood vessels and nerves. In addition to its supportive role, it also stores calcium and other minerals, and manufactures blood cells.

The skeleton is divided into two parts. The axial skeleton forms the axis of the body trunk and consists of the skull, which protects the brain; the vertebral column, which surrounds the spinal cord; and the ribs, which encircle the heart and lungs, and assist in breathing. The appendicular skeleton consists of the bones of the arms and legs, as well as those of the pectoral (shoulder) and pelvic (hip) girdles that attach the limbs to the axial skeleton. Where two or more bones meet, a joint is formed. Joints are held together and stabilized by tough, straplike ligaments. Muscles attached to the bones on both sides of a joint produce movement when they contract.

BONES OF THE BODY

There are four basic types of bones that make up the body's internal framework: long bones, such as the femur and humerus; flat bones, such as the ribs and most skull bones; short bones, such as the carpals and tarsals; and irregular bones, such as the vertebrae.

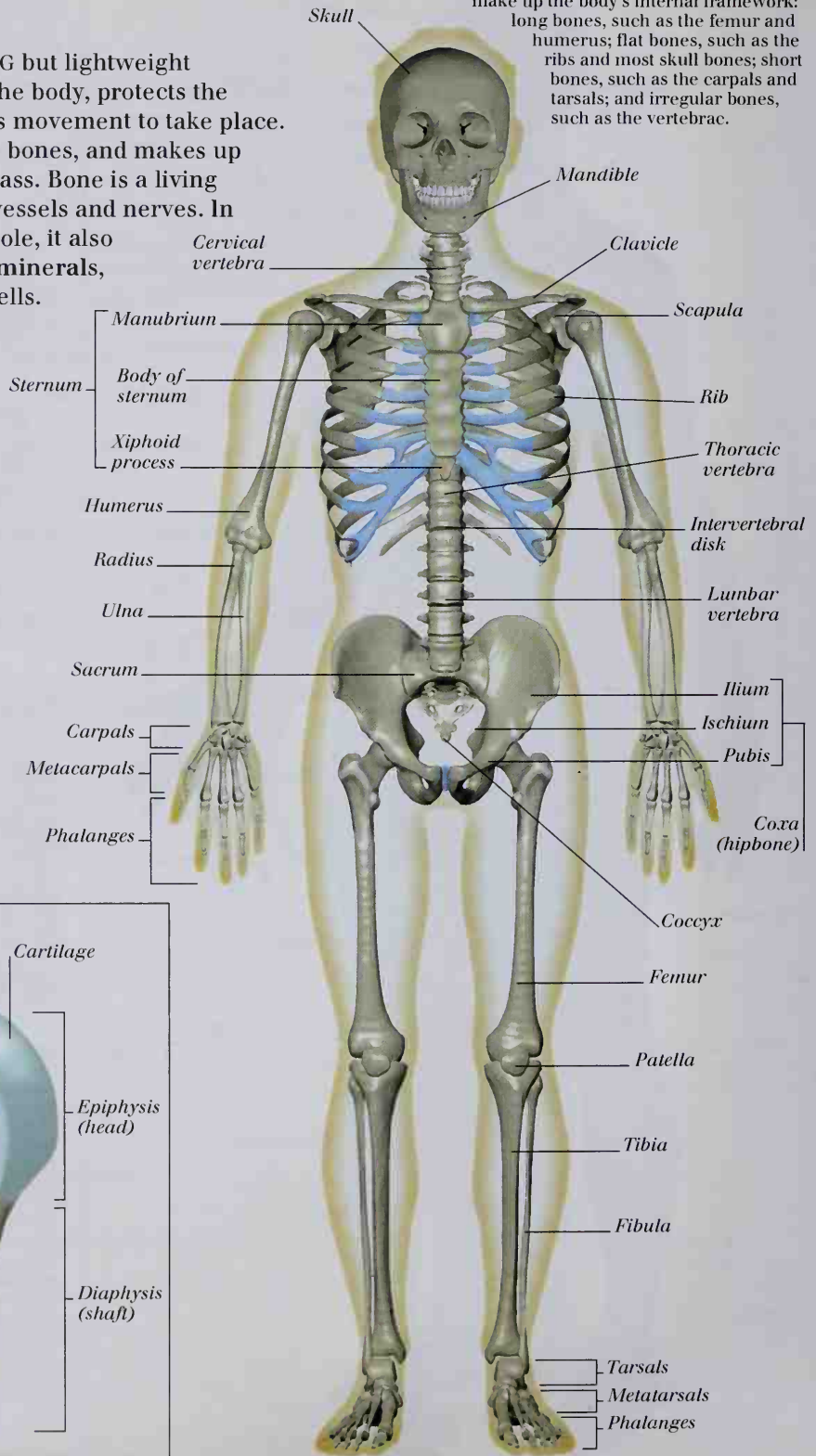

BONE STRUCTURE

The combination of an outer covering of dense compact bone with an inner layer of lighter, spongy bone, makes bones both strong and light. A medullary canal, which contains marrow, runs along the length of the shaft of long bones.

Spongy (cancellous) bone

Compact bone

Medullary cavity

Yellow bone marrow

Periosteum (thin membrane covering bone surface)

Artery

Cartilage

Epiphysis (head)

Diaphysis (shaft)

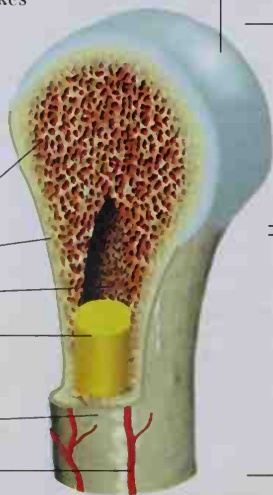

EXPLODED LATERAL VIEW OF THE SKULL

The skull surrounds and protects the brain and forms the framework of the face. It consists of 22 bones. Apart from the freely movable mandible (lower jaw), these bones are united by immovable interlocking joints called sutures.

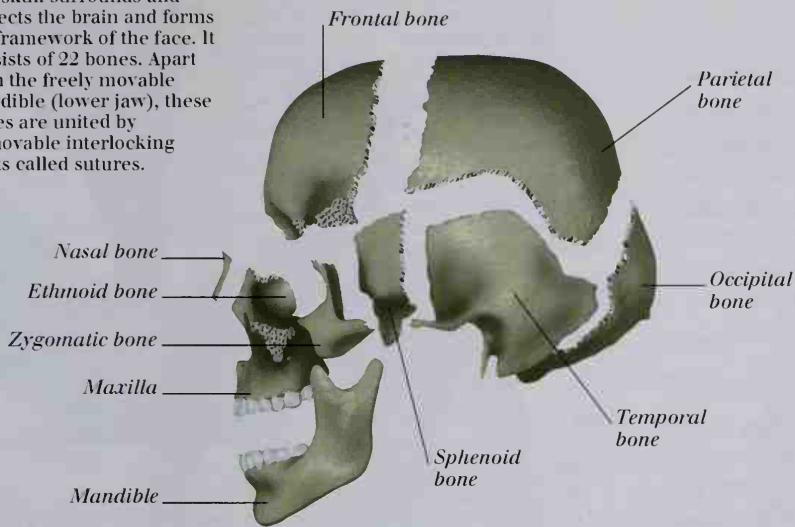

THE SPINE (VERTEBRAL COLUMN)

The S-shaped vertebral column, which consists of 55 vertebrae, supports the head and trunk. Cartilage disks in the joints between pairs of vertebrae individually allow only limited movement, but collectively produce considerable flexibility. This allows the body to bend and twist.

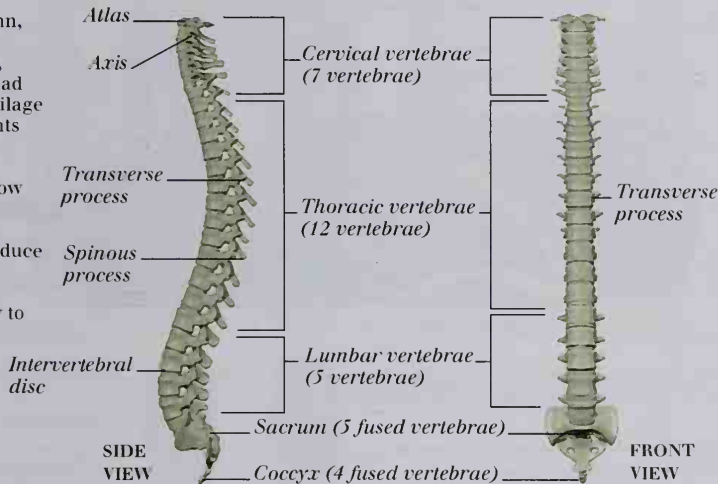

EXPLODED LATERAL VIEW OF THE PELVIS

The pelvis is made up of the pelvic girdle and the sacrum. The pelvic girdle consists of two hipbones that are formed by the fusion of three bones (the ilium, ischium, and pubis) and connected at the pubic symphysis.

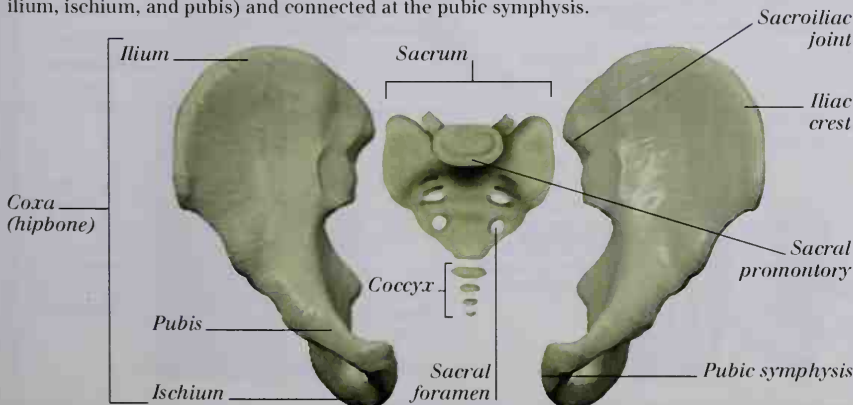

MOVABLE JOINTS

Some joints between bones show little or no movement, but most joints are freely movable. Four types of movable joints are shown below.

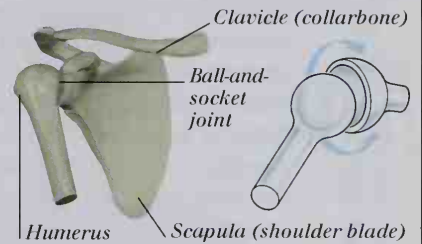

BALL-AND-SOCKET JOINT

Both hip and shoulder are ball-and-socket joints. Here, the spherical head of one bone moves inside the cup-shaped socket of another – an arrangement that permits movement in all planes.

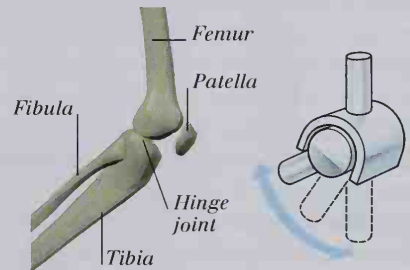

HINGE JOINT

Hinge joints, which include the knee, elbow, and the interphalangeal joints of the finger, move in one plane, like the hinge of a door.

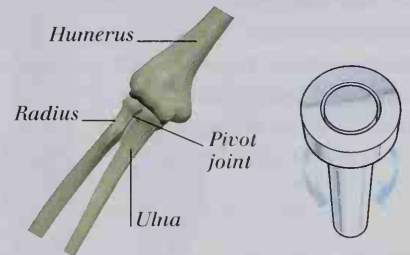

PIVOT JOINT

Here, the end of one bone rotates inside a ring formed by another. The radius and ulna form a pivot joint that allows the forearm to twist.

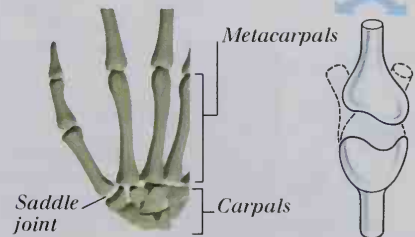

SADDLE JOINT

This joint permits movement both backward and forward, and side to side, with limited rotation. It is found at the base of the thumb.

Muscles



MUSCLE IS TISSUE that can contract, or shorten, in response to a nerve impulse (message) from the central nervous system (the brain and spinal cord). Three types of muscles – skeletal, smooth, and cardiac – make up nearly 40 percent of the body's weight. Over 600 skeletal, or voluntary, muscles operate under conscious control to move the body, stabilize joints, and maintain body

posture. Skeletal muscles are attached to bones by tough, fibrous cords called tendons. Typically, each muscle connects two bones by stretching across the joint between them. When the muscle contracts, one bone (the muscle's origin) remains fixed in position, while the other (the muscle's insertion) moves. Muscles lying near the skin's surface are called superficial, while those layered beneath them are called deep. Smooth, or involuntary, muscle is found in the walls of hollow organs, such as the intestine, and performs functions that are not under conscious control, such as moving partially digested food. Cardiac muscle is found only in the heart. It contracts rhythmically to pump blood around the body, but needs external nerve stimulation to accelerate or slow its pace.

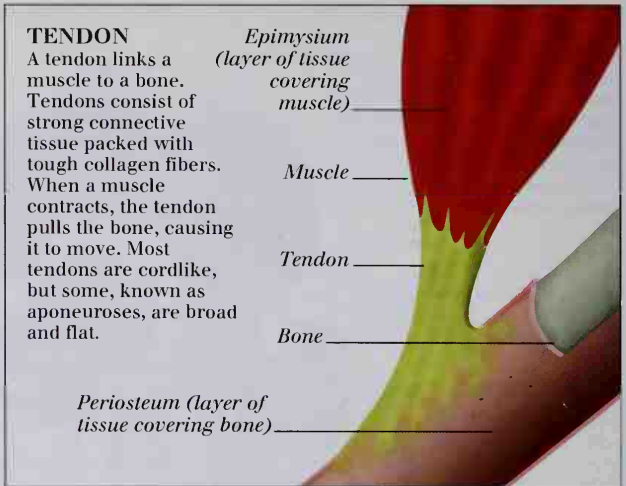

TENDON

A tendon links a muscle to a bone. Tendons consist of strong connective tissue packed with tough collagen fibers. When a muscle contracts, the tendon pulls the bone, causing it to move. Most tendons are cordlike, but some, known as aponeuroses, are broad and flat.

NEUROMUSCULAR JUNCTION

Skeletal muscle fibers (cells) contract when stimulated by nerve impulses arriving along a motor neuron (nerve cell). A neuromuscular (nerve-muscle) junction is the site at which motor neuron and muscle fiber meet but do not touch; there is a tiny gap, or synapse, between them, across which impulses are chemically transmitted.

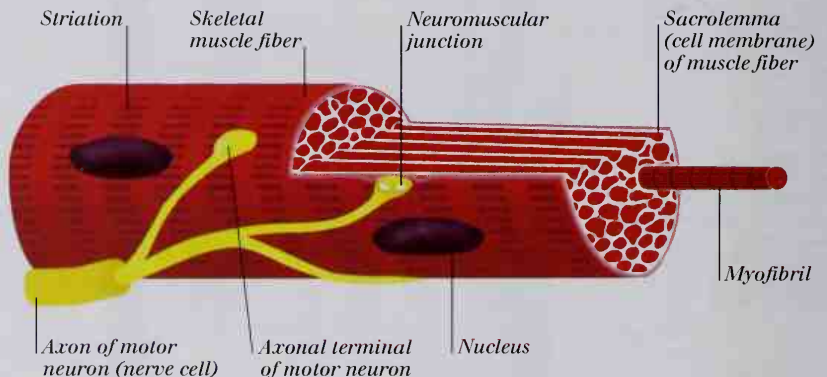

TYPES OF MUSCLE

SKELETAL MUSCLE

Skeletal muscle makes up the bulk of the body's muscles. It consists of long, cylindrical muscle fibers (cells), which lie parallel to each other. Each fiber has a regular pattern of transverse striations (bands).

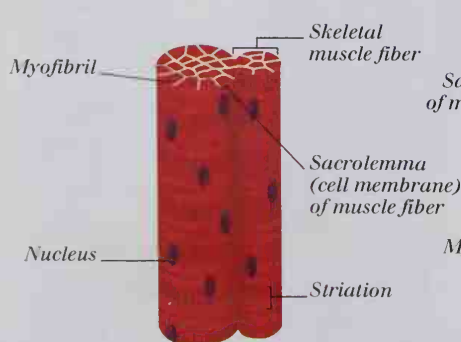

SMOOTH MUSCLE

Smooth muscle, found in the walls of internal organs, consists of short, spindle-shaped muscle fibers (cells) packed together in muscle sheets. Its slow, sustained contractions are not under voluntary control.

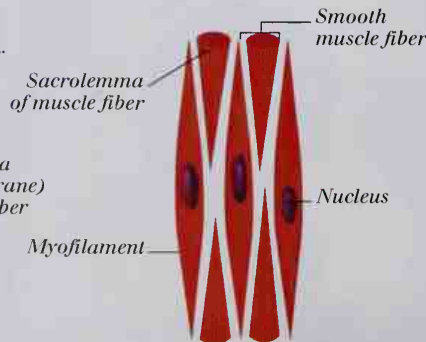

CARDIAC MUSCLE

Cardiac muscle, contained in the heart wall, consists of anastomosing (branched) chains of muscle fibers (cells) which, like skeletal fibers, are striated. It relaxes and contracts automatically, and never tires.

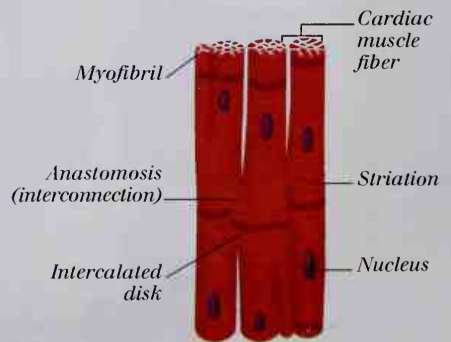

MAJOR SKELETAL MUSCLES

ANTERIOR VIEW

This view shows the main superficial muscles of the front of the head, trunk, and upper and lower limbs.

Frontalis

Temporalis

Orbicularis oculi

Nasalis

Orbicularis oris

Trapezius

Deltoid

Pectoralis major

Triceps brachii

Biceps brachii

Brachialis

Extensor muscles of wrist and fingers

Gluteus maximus

Sartorius

Vastus lateralis

Vastus medialis

Gastrocnemius

Soleus

Plantaris

Gastrocnemius

Soleus

Flexor digitorum longus

Tendon of extensor digitorum longus

Tendon of extensor hallucis longus

Masseter

Sternocleidomastoid

Latissimus dorsi

Serratus anterior

External oblique

Flexor muscles of wrist and fingers

Aponeurosis of external oblique

Iliopsoas

Pectineus

Adductor longus

Rectus femoris

Gracilis

Peroneus longus

Tibialis anterior

Extensor digitorum longus

Tendon of extensor digitorum longus

Tendon of extensor hallucis longus

Shoulder

Biceps brachii partially contracted

Triceps brachii relaxed

Forearm

EXTENDED FOREARM

Skeletal muscles, which include the biceps brachii and triceps brachii, are often arranged in antagonistic (opposing) pairs.

Shoulder

Biceps brachii partially contracted

Triceps brachii relaxed

Forearm

EXTENDED FOREARM

Skeletal muscles, which include the biceps brachii and triceps brachii, are often arranged in antagonistic (opposing) pairs.

POSTERIOR VIEW

This view shows the main superficial muscles of the back of the head, trunk, and upper and lower limbs.

Occipitalis

Sternocleidomastoid

Splenius capitis

Latissimus dorsi

Triceps brachii

Biceps brachii

Brachialis

Extensor muscles of wrist and fingers

Gluteus maximus

Sartorius

Vastus lateralis

Vastus medialis

Gastrocnemius

Soleus

Plantaris

Gastrocnemius

Soleus

Flexor digitorum longus

Tendon of extensor digitorum longus

Tendon of extensor hallucis longus

Shoulder

Biceps brachii contracts

Triceps brachii relaxes

Forearm

FOREARM FLEXION

Each member of the pair works against the other. The biceps contracts to flex (bend) the forearm, while the triceps relaxes.

Shoulder

Biceps brachii contracts

Triceps brachii relaxes

FOREARM FLEXION

Each member of the pair works against the other. The biceps contracts to flex (bend) the forearm, while the triceps relaxes.

Trapezius

Deltoid

Infraspinatus

Teres major

Latissimus dorsi

Extensor digitorum

External oblique

Gluteus medius

Adductor magnus

Biceps femoris

Gracilis

Seminembranosus

Peroneus longus

Peroneus brevis

Shoulder

Biceps brachii relaxes

Triceps brachii contracts

Forearm

FOREARM EXTENSION

The triceps contracts to extend the forearm, while the biceps relaxes and lengthens passively. Muscles can only pull, not push.

Shoulder

Biceps brachii relaxes

Triceps brachii contracts

FOREARM EXTENSION

The triceps contracts to extend the forearm, while the biceps relaxes and lengthens passively. Muscles can only pull, not push.

Shoulder

Biceps brachii relaxes

Triceps brachii contracts

FOREARM EXTENSION

The triceps contracts to extend the forearm, while the biceps relaxes and lengthens passively. Muscles can only pull, not push.

MUSCLE ACTION

EXTENDED FOREARM

Skeletal muscles, which include the biceps brachii and triceps brachii, are often arranged in antagonistic (opposing) pairs.

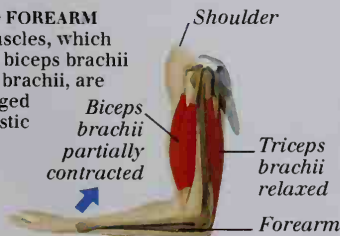

FOREARM FLEXION
Each member of the pair works against the other. The biceps contracts to flex (bend) the forearm, while the triceps relaxes.

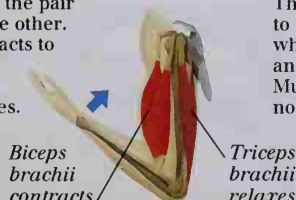

FOREARM EXTENSION

The triceps contracts to extend the forearm, while the biceps relaxes and lengthens passively. Muscles can only pull, not push.

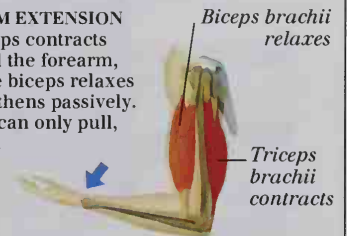

Brain, spinal cord, and nerves



THE BRAIN, SPINAL CORD, AND NERVES together form the nervous system, the communication network of the body. It has two main parts: the central nervous system (CNS), which consists of the brain and spinal cord, and is the control center of the network; and the peripheral nervous system (PNS), which consists of cablelike nerves that link the CNS to the rest of the body. The nervous system contains billions of intercommunicating neurons, highly specialized cells capable of rapidly

transmitting impulses (one-way electrochemical messages). There are three types of neurons. The first, sensory neurons, carry impulses from internal and external sensory receptors, such as the eye and ear, to the CNS, constantly updating it about events occurring both inside and outside the body. The second type, motor neurons, transmit impulses from the CNS to effector organs, such as muscles, instructing them to respond by contracting. Sensory and motor neurons are bundled together to form nerves. The third type, association neurons, are found only in the CNS, and link sensory and motor neurons. They form complex pathways that enable the brain to interpret incoming sensory messages, compare them with past experiences, decide on what should be done, and send out instructions in response along motor pathways to keep the body functioning properly.

THE NERVE NETWORK

Twelve pairs of cranial nerves arising from the brain, and 31 pairs of spinal nerves arising from the spinal cord, connect the brain and spinal cord to all parts of the body.

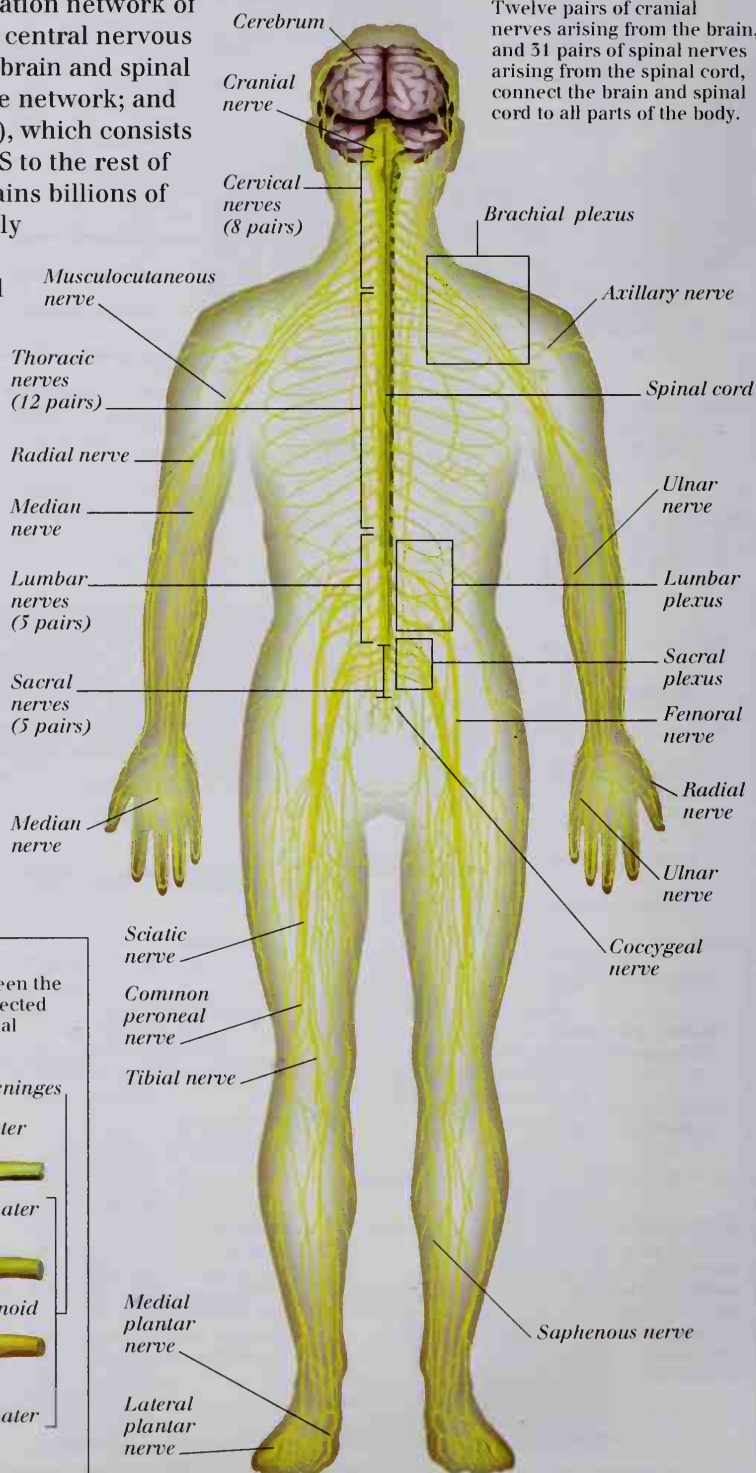

ANATOMY OF THE SPINAL CORD

The spinal cord forms a two-way information pathway between the brain and the rest of the body via the spinal nerves. It is protected by three layers of tissue called meninges and by cerebrospinal fluid circulating in the subarachnoid space.

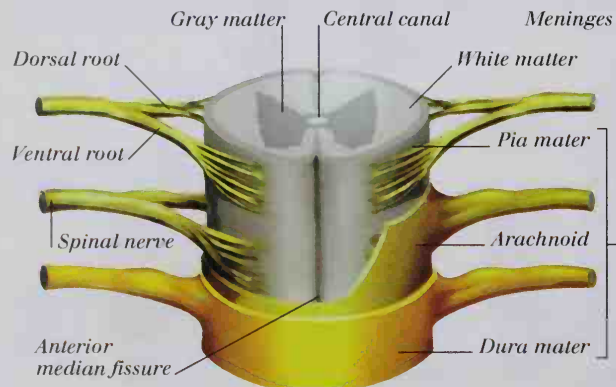

THE BRAIN

The brain, with the spinal cord, controls and coordinates all body functions. The largest part of the brain is the cerebrum, which is divided into two halves, the left and right cerebral hemispheres. The outer, thin layer of the cerebrum (the cerebral cortex) consists of gray matter (the cell bodies of neurons); the inner part is white matter (nerve fibers). The cerebral cortex is the site of conscious behavior. Different areas of the

cortex are responsible for different functions, such as movement, touch, vision, hearing, and thought. The cerebellum, the second largest part of the brain, coordinates balance and movement. The brain stem (the midbrain, pons, and medulla oblongata) regulates heartbeat, breathing, and other vital functions. The thalamus relays and sorts the nerve impulses that pass between the spinal cord and brain stem, and the cerebrum.

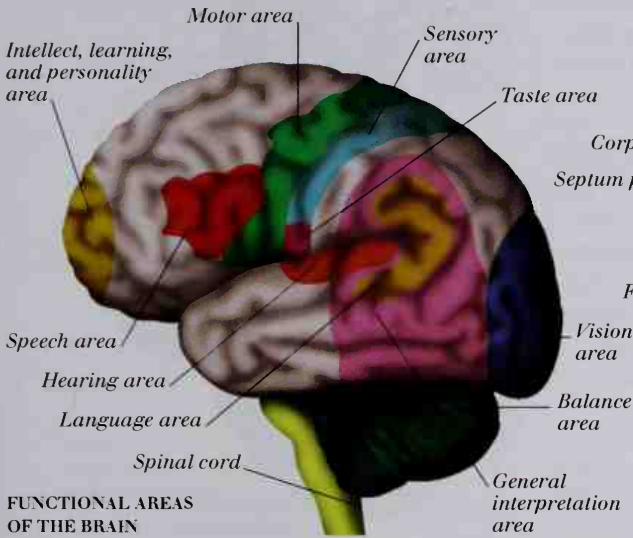

FUNCTIONAL AREAS OF THE BRAIN

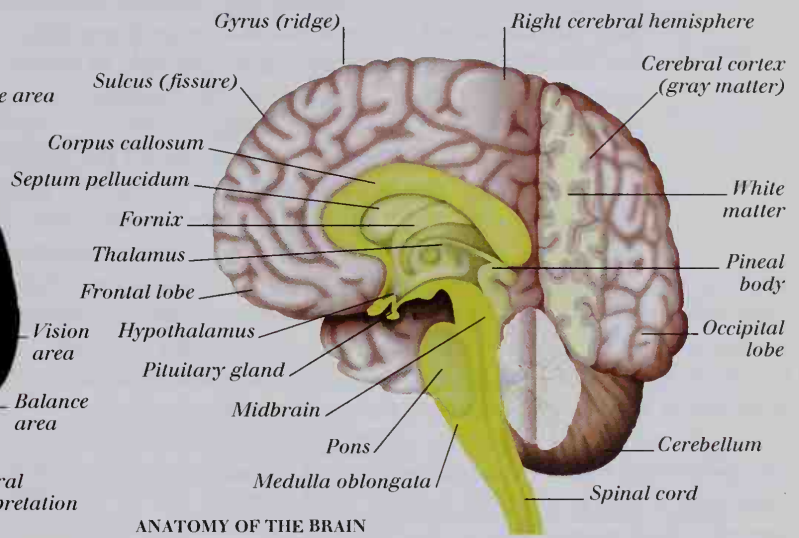

ANATOMY OF THE BRAIN

NERVES AND NEURONS

Neurons are the basic structural units of the nervous system. They typically consist of a cell body, which lies in or near the central nervous system (brain and spinal cord); a single long process (the nerve fiber or axon), which carries nerve impulses; and short,

multiple branches (dendrites), which carry impulses from one neuron to the next and link each neuron with many others. Nerves are long, cordlike organs that consist of bundles of the nerve fibers of both sensory and motor neurons.

NERVE STRUCTURE

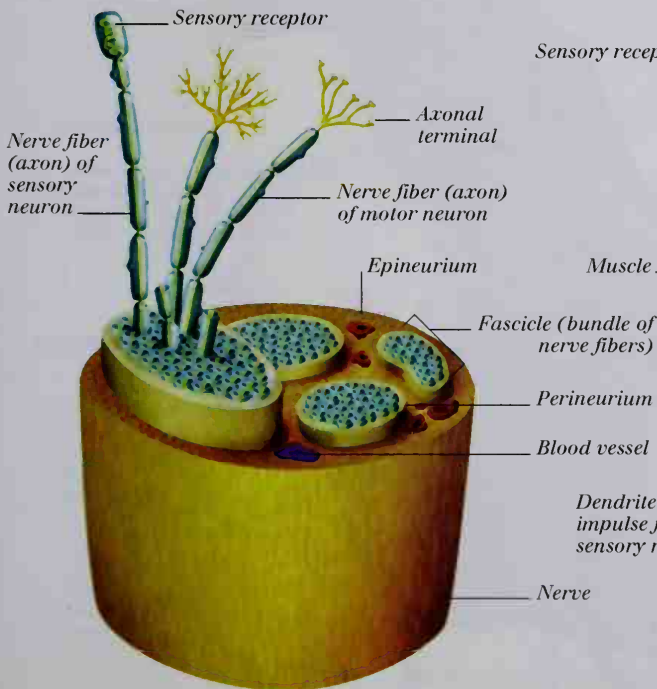

A SIMPLE NERVE PATHWAY

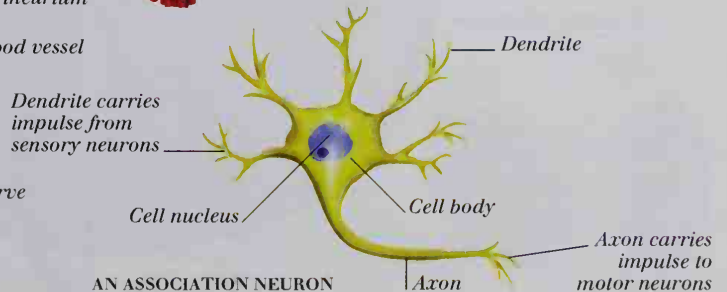
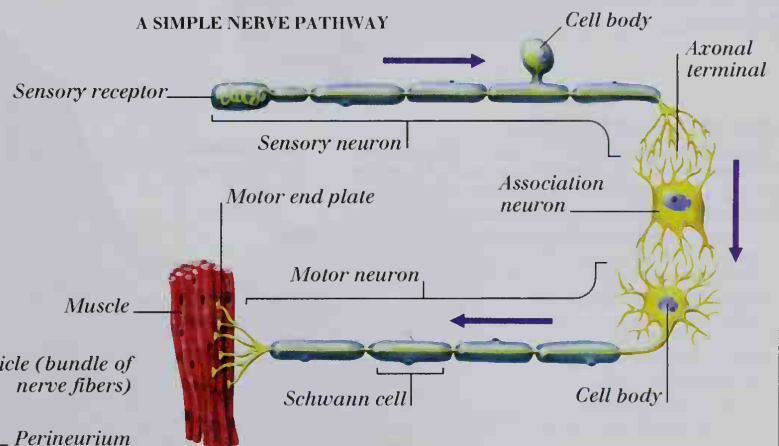

AN ASSOCIATION NEURON

Endocrine system



THE ENDOCRINE, OR HORMONAL, SYSTEM consists of a number of endocrine glands, which are scattered around the body. These glands manufacture chemical messengers called hormones and release them into the bloodstream. Hormones control the rate at which specific target organs or glands work. Together, the endocrine system and the nervous system (see pp. 186-187) control and coordinate all the body's activities. While the nervous system acts rapidly, with short-lived results, hormones act more slowly, and with longer-lasting effects. The endocrine glands include the pineal, which controls the daily rhythms of sleeping and waking; the parathyroids, which determine calcium levels in the blood; the thyroid, which controls metabolism (the rate at which the body uses energy); the adrenals, which release a number of hormones, including fast-acting epinephrine, which increases the heart rate under stress conditions; the pancreas, which controls the level of blood glucose (the body's energy supply); and the ovaries and testes, which release the sex hormones that produce secondary sexual characteristics, such as breasts in women and facial hair in men. Most, but not all, endocrine glands are controlled by hormones released by the pituitary gland in the brain. This, in turn, is controlled by the hypothalamus – an adjacent part of the brain.

THE PITUITARY GLAND

The pituitary consists of two parts. The anterior lobe produces a number of hormones, including growth hormone and thyroid-stimulating hormone, which stimulates the thyroid gland to release hormones. The posterior lobe stores two hormones produced by the hypothalamus: oxytocin, which causes uterine contractions during labor, and antidiuretic hormone, which controls urine concentration.

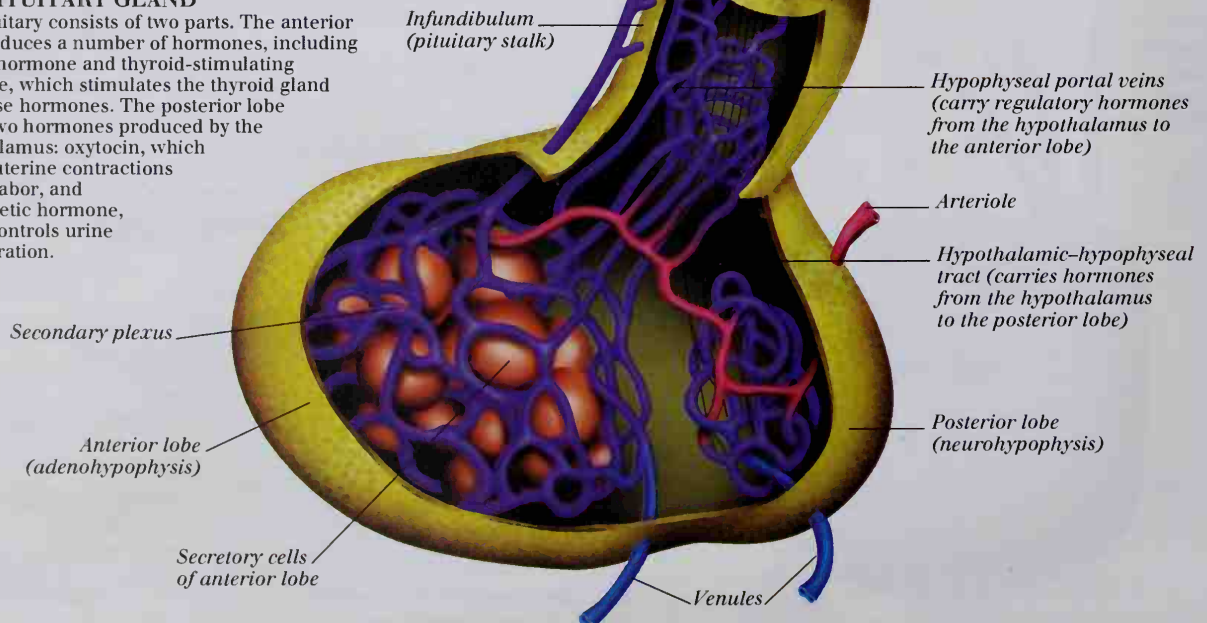

ENDOCRINE GLANDS OF THE BRAIN

The hypothalamus plays an important part in coordinating hormone production. It sends instructions to the nearby pituitary gland, which then releases hormones that target other endocrine glands.

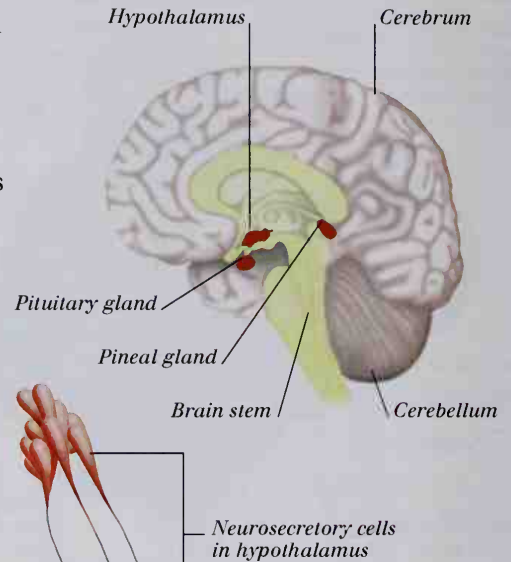

HOW THE ENDOCRINE SYSTEM WORKS

Hormones manufactured by an endocrine gland are secreted into the circulatory system, and carried in the blood to specific target tissues. Here, they attach themselves to tissue cells and exert their effect.

THE RELEASE OF HORMONES INTO THE BLOODSTREAM

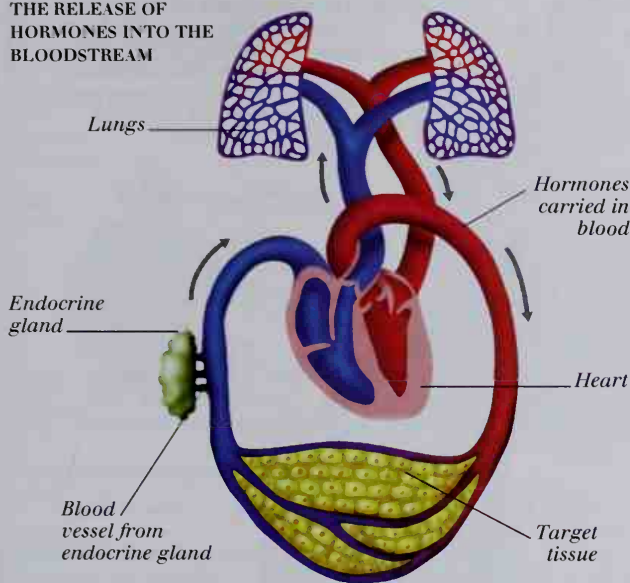

ENDOCRINE GLANDS

Even though they are scattered around the body, most of the endocrine glands come under the control of the pituitary gland.

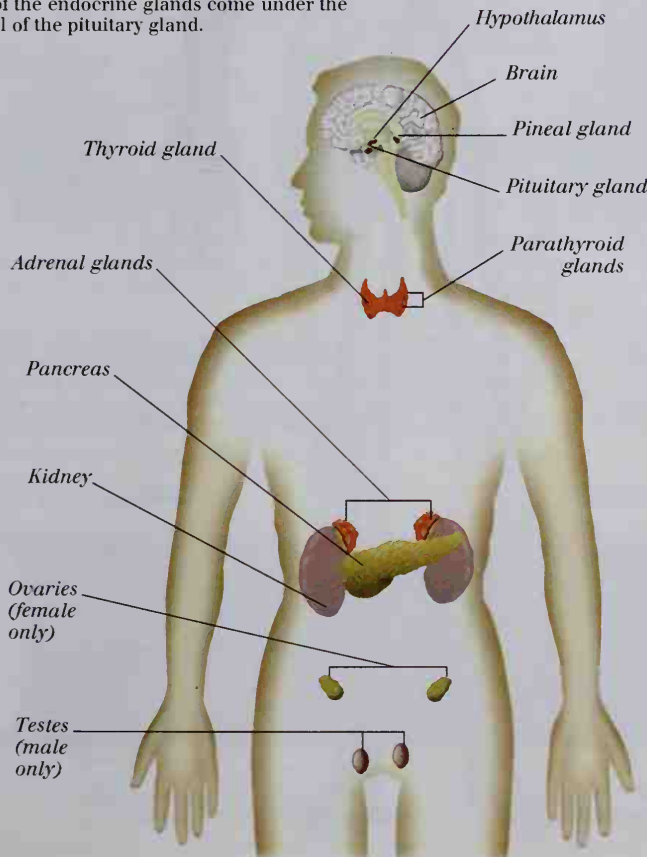

HORMONE-PRODUCING GLANDS

The hormone-producing endocrine glands are also known as ductless glands. Unlike other glands, such as salivary glands, which release their products along ducts, endocrine glands release their products directly into the bloodstream.

POSTERIOR VIEW OF THE THYROID GLAND

The thyroid gland produces two hormones: thyroxine, which speeds up metabolism, and calcitonin, which decreases calcium levels in the blood. The parathyroids produce parathyroid hormone, which increases blood calcium levels.

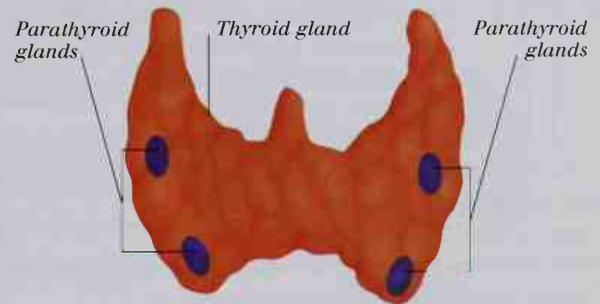

THE PANCREAS

The pancreas produces two hormones, insulin and glucagon, which respectively decrease and increase the level of blood glucose to keep it within set limits. The pancreas also has an exocrine (ducted) portion that produces digestive enzymes.

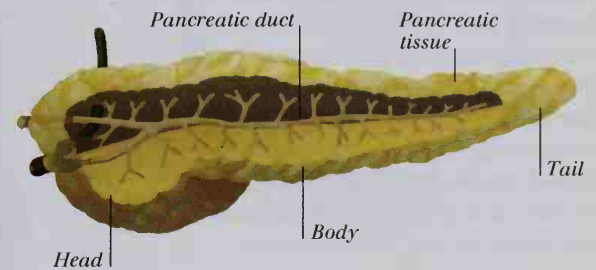

ADRENAL GLANDS

On top of each kidney there is an adrenal gland. The outer part (cortex) produces corticosteroids, which regulate blood concentration and influence metabolism. The inner part (medulla) produces epinephrine, which prepares the body for dealing with stress or danger by increasing heart and breathing rate.

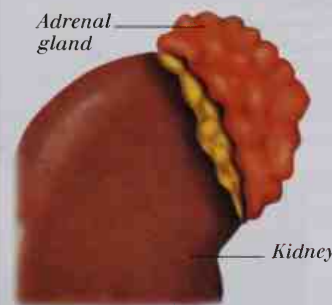

OVARIES AND TESTES

Testes release testosterone, which controls sperm production. Ovaries release progesterone and estrogen, which prepare women's bodies for pregnancy. Secondary sexual characteristics, such as facial hair and breasts, are also produced by these hormones.

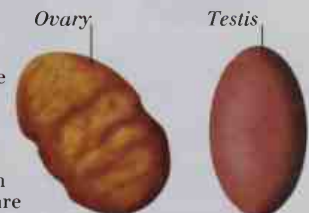

Heart and blood vessels



THE HEART AND BLOOD VESSELS, together with the blood they contain, form the cardiovascular, or circulatory, system. This transports **nutrients** and **oxygen** to all body cells and removes their waste products. It also carries specialized cells that help protect against infection. The heart is a powerful muscle. It pumps blood around the circuit of blood vessels that supplies the whole body.

There are two circulatory routes: the pulmonary circulation, which carries blood through the lungs, and the systemic circulation, which carries blood through body tissues. The heart is composed of two halves, each divided into an atrium (upper chamber) and a ventricle (lower chamber). Blood returning from the body to the heart is low in oxygen. It enters the right atrium, passes into the right ventricle, and is pumped into the lungs, where it is enriched with oxygen. The oxygen-rich blood passes back into the left atrium and is pumped back into the body via the left ventricle.

THE CIRCULATORY SYSTEM

This consists of a massive network of over 100,000 km (60,000 miles) of blood vessels (arteries, veins, and capillaries). This circulates blood between the heart and all parts of the body.

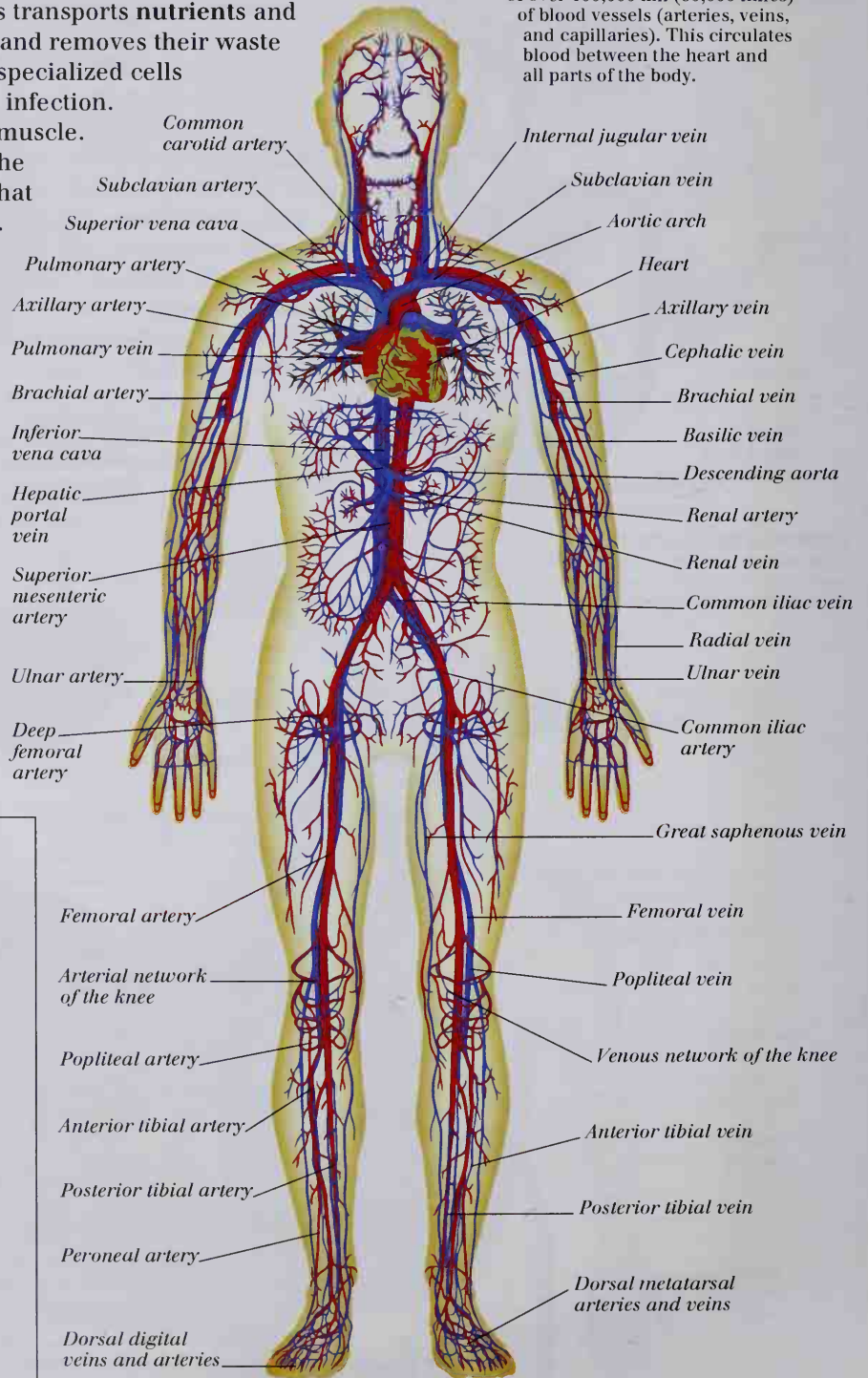

BLOOD VESSELS

Thick-walled arteries carry blood at high pressure. They branch repeatedly to form microscopic capillaries that carry blood through the tissues, and then merge to form veins that carry blood back to the heart.

ARTERY

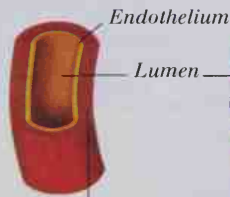

VEIN



Middle layer of smooth muscle

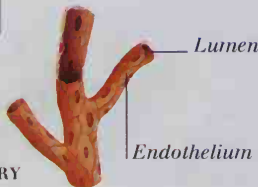

CAPILLARY

THE HEART

The heart is made of cardiac muscle that contracts automatically and never tires. The left pump pushes blood around the body; the right pump pushes blood into the lungs. Both sides beat together in a cycle with three stages: diastole, atrial systole, and ventricular systole.

ANTERIOR VIEW

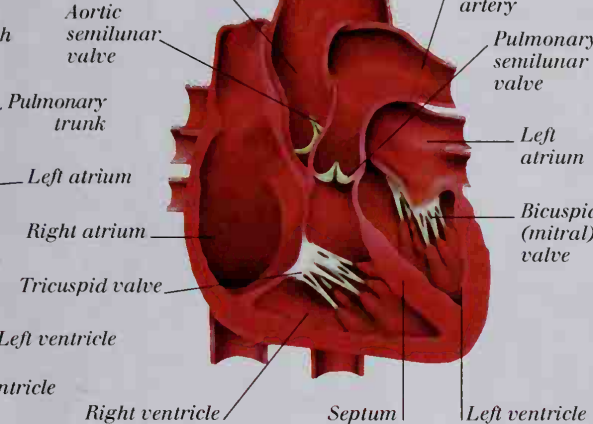
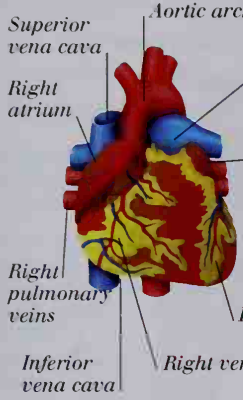

DIASTOLE

Blood returning from the body flows into the right atrium, and oxygen-rich blood flowing from the lungs flows into the left atrium.

ATRIAL SYSTOLE

The right and left atria contract to push blood into the ventricles. The semilunar valves close to stop blood flowing back into the heart.

VENTRICULAR SYSTOLE

The ventricles contract to push blood out of the heart through semilunar valves. The bicuspid and tricuspid valves close to prevent backflow.

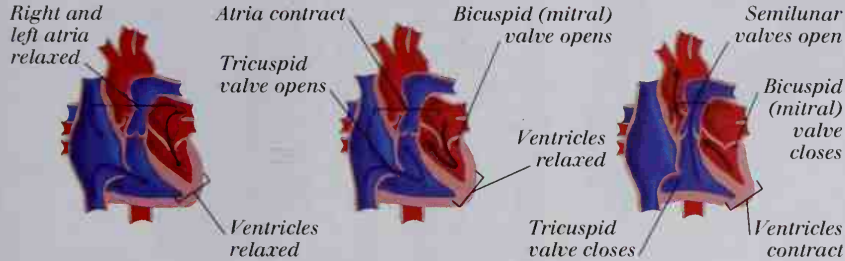

SYSTEMIC AND PULMONARY CIRCULATIONS

The circulatory system has two parts. The systemic circulation carries oxygen-rich blood to all body tissues except the lungs, and returns oxygen-poor blood to the right atrium. The pulmonary circulation carries oxygen-poor blood from the right ventricle to the lungs, and returns oxygen-rich blood to the left atrium.

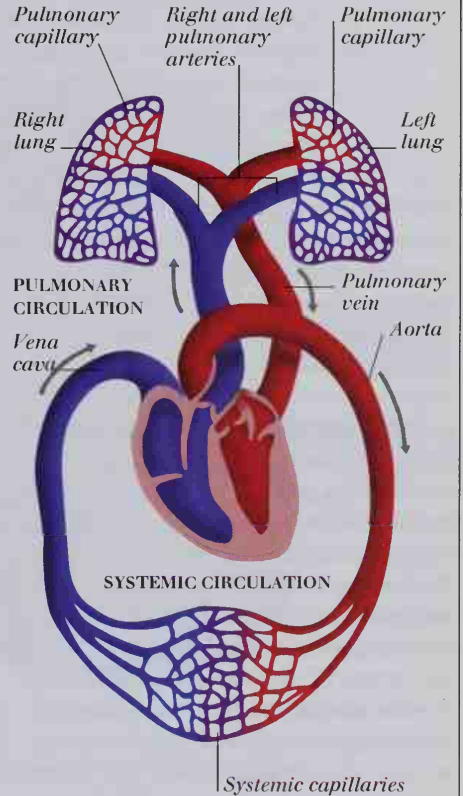

STRUCTURE AND FUNCTIONS OF BLOOD

Blood is a liquid tissue consisting of 55 percent plasma (a yellowish fluid that contains proteins) and 45 percent blood cells. Suspended in the plasma are red and white blood cells, and cell fragments called platelets. Blood has two main functions: transport and defense. Plasma transports nutrients and hormones to cells, and removes

wastes. Erythrocytes (red blood cells) carry oxygen. Three types of white blood cells protect the body against infection: neutrophils and monocytes hunt and eat invaders; lymphocytes produce chemicals called antibodies that destroy foreign cells. Platelets help the blood clot when a wound occurs.

COMPONENTS OF BLOOD

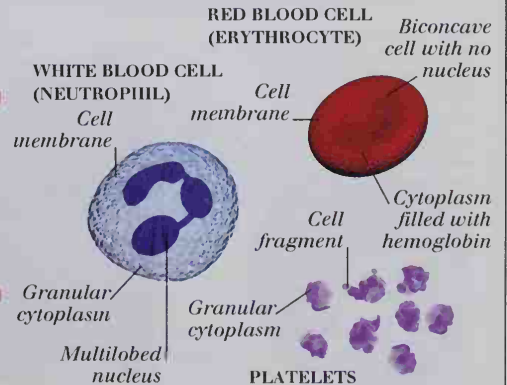
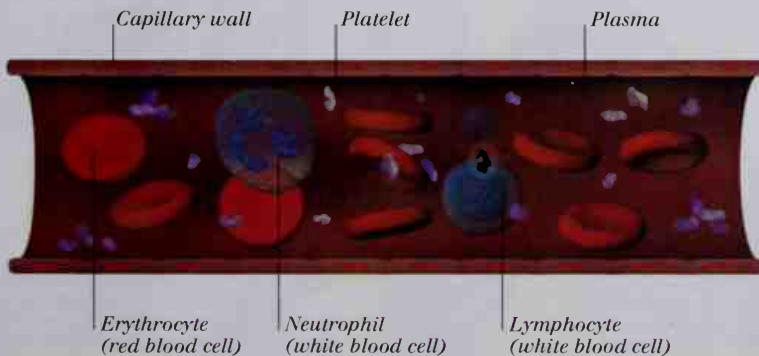

Lymphatic system



THE LYMPHATIC SYSTEM removes excess fluid from the body's tissues and returns it to the circulatory system. It also helps the body fight infection. It consists of lymphatic vessels, lymph nodes, and associated lymphoid organs, such as the spleen and tonsils. Lymph vessels form a network of tubes that reach all over the body. The smallest vessels – lymphatic capillaries – end blindly in the

body's tissues. Here, they collect a liquid called lymph, which leaks out of blood capillaries and accumulates in the tissues. Once collected, lymph flows in one direction along progressively larger vessels: firstly, lymphatic vessels; secondly, lymphatic trunks; and, finally, the thoracic and right lymphatic ducts, which empty the lymph into the bloodstream. Lymph nodes are swellings along lymphatic vessels that defend the body against disease by filtering disease-causing microorganisms, such as bacteria, as lymph passes through them. There are two types of defensive cells in lymph nodes: macrophages, which engulf microorganisms, and lymphocytes, which release antibodies that target and destroy microorganisms. Lymphoid organs also contain defensive cells that destroy microorganisms found in blood or, in the case of the tonsils, air. Lymphoid organs do not filter lymph.

THE LYMPHATIC SYSTEM

Fluid lost from the blood is constantly accumulating in the body's tissues. The lymphatic network returns this excess fluid back into the bloodstream, and at the same time filters out disease-causing microorganisms.

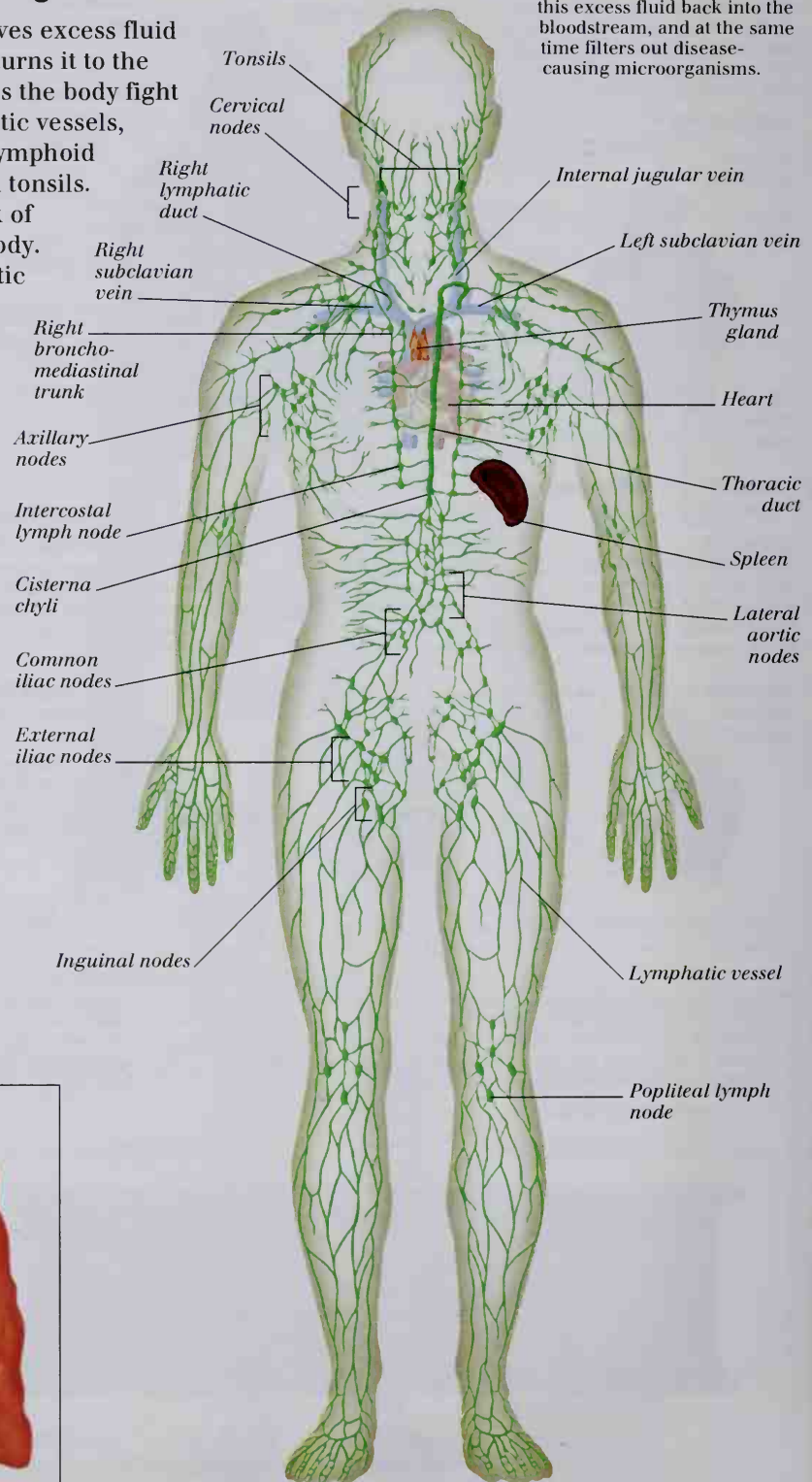

THE THYMUS GLAND

This lymphoid organ assists in the production of cells called "T lymphocytes," which target specific disease-causing microorganisms for destruction and help defend the body against infection. The thymus is most active in children and gradually shrinks during adulthood.



Right lobe

Left lobe

HOW THE LYMPHATIC SYSTEM WORKS

Lymph capillaries join to form larger lymphatic vessels, which transport lymph and empty it into the bloodstream.

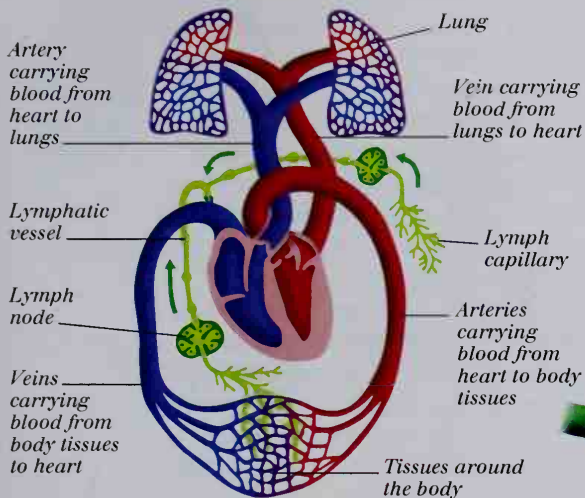

STRUCTURE OF A LYMPH NODE

Hundreds of these small, bean-shaped organs are clustered along lymphatic vessels. Each one is surrounded by a capsule and divided into compartments by trabeculae. These compartments contain a network of fibers supporting the lymphocytes and macrophages that filter out foreign microorganisms and general debris. This process "cleans up" the lymph as it flows through the lymph node.

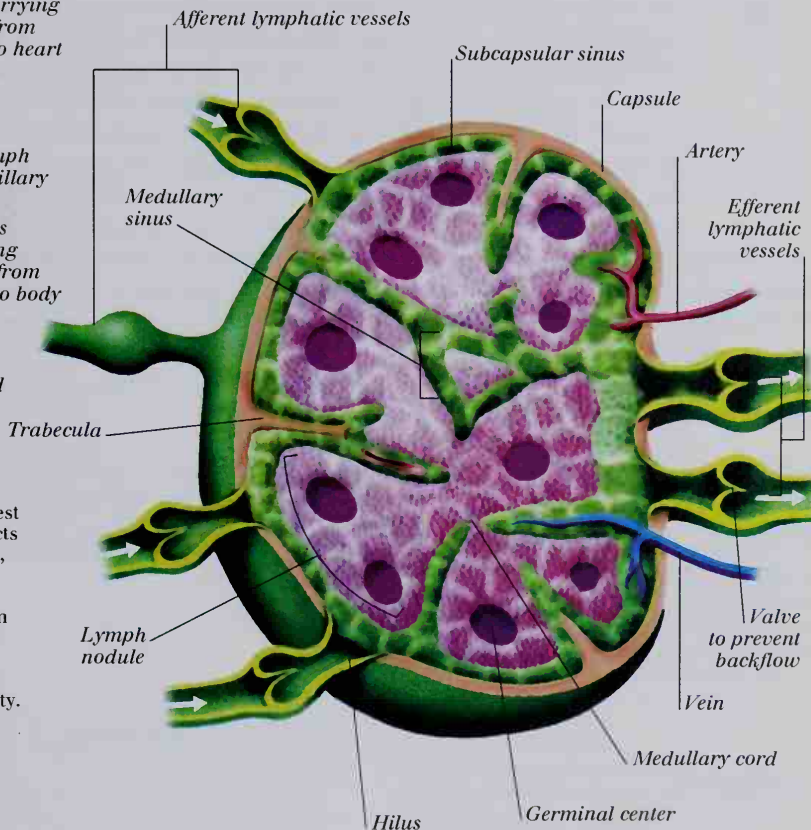

THE SPLEEN

The spleen is the largest lymphoid organ. It acts as a blood reservoir, removes worn-out red blood cells (erythrocytes) from the blood, and provides a site for lymphocyte and macrophage activity.

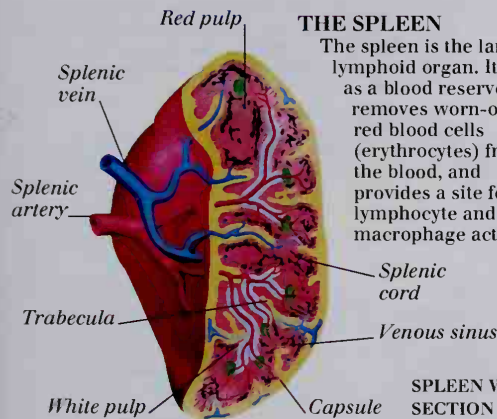

SPLEEN WITH SECTION REMOVED

ANTIBODY AND CELLULAR DEFENSES

The body has two mechanisms to protect itself from infection. The antibody defense system employs lymphocytes that release killer chemicals called antibodies. When substances called antigens - located on the surface of bacteria, viruses, and other disease-causing microorganisms - are detected, the antibodies target them and either

disable or destroy them. The cellular defense system employs phagocytes ("cell eaters"), which seek out invaders, engulf them, and destroy them. Lymphocytes and phagocytes are found in both lymphatic and circulatory systems, and phagocytes also wander through the tissues. One type of phagocyte is called a macrophage.

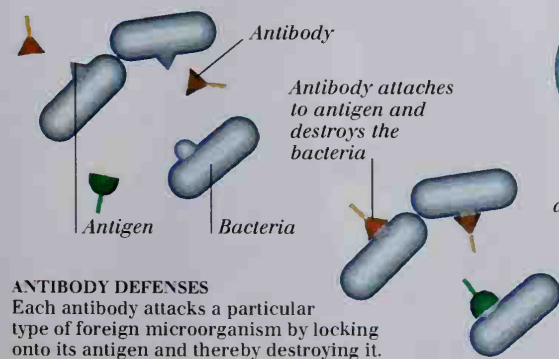

ANTIBODY DEFENSES
Each antibody attacks a particular type of foreign microorganism by locking onto its antigen and thereby destroying it.

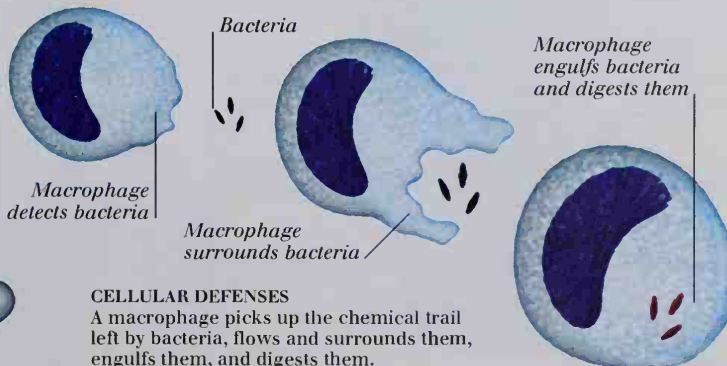

CELLULAR DEFENSES
A macrophage picks up the chemical trail left by bacteria, flows and surrounds them, engulfs them, and digests them.

Respiratory organs



THE RESPIRATORY ORGANS CONSIST OF THE NOSE, pharynx (throat), larynx (voice box), trachea (windpipe), the bronchi (sing. bronchus), and the lungs. Collectively, they form the respiratory system, which supplies the body with **oxygen** and removes waste **carbon dioxide**. Air is moved into and out of the respiratory system by breathing. During inhalation (breathing in), air is drawn in through the nose, pharynx, trachea and bronchi, and into the lungs. Inside the lungs, each bronchus divides repeatedly to form a “tree” of tubes called bronchioles, which progressively decrease in diameter and end in microscopic air sacs called alveoli (sing. alveolus). Oxygen from the air that reaches the alveoli diffuses through the alveolar walls and into the surrounding blood capillaries. This oxygen-rich blood is carried first to the heart and is then pumped to cells throughout the body. Carbon dioxide diffuses out of the blood into the alveoli and is removed from the body during exhalation (breathing out). Breathing is the result of muscular contraction. During inhalation, the **diaphragm** and **intercostal muscles** contract to enlarge the **thorax** (chest), decreasing pressure inside the thorax, so that air from the outside of the body enters the lungs. During exhalation, the muscles relax to decrease the volume of the thorax, increasing its internal pressure so that air is pushed out of the lungs.

LATERAL VIEW OF THE LARYNX

The larynx (voice box) links the pharynx with the trachea. It consists of an arrangement of nine pieces of cartilage and has two main functions. First, during swallowing, the upper cartilage (the epiglottis) covers the larynx to stop food from going into the lungs. At other times, the epiglottis is open, and the larynx provides a clear airway. Second, the larynx plays a part in voice production. Sound is produced as vocal cords vibrate in the stream of air flowing out of the body.

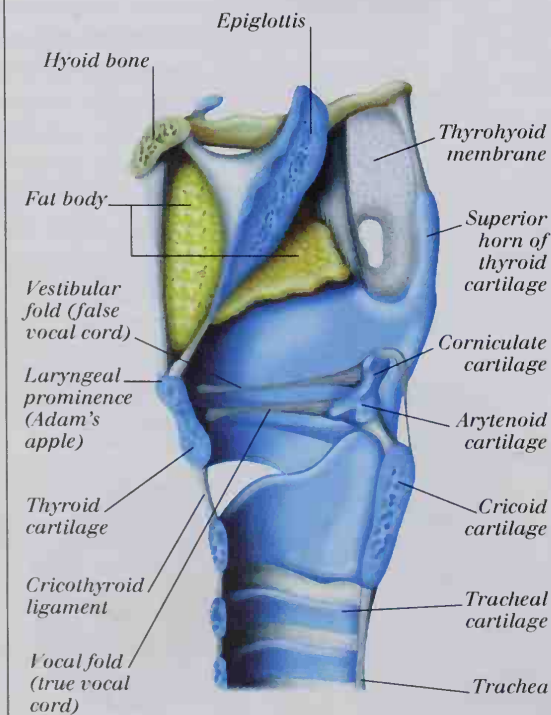

THE RESPIRATORY SYSTEM

The two lungs are located on either side of the heart. The left lung has one oblique fissure, dividing it into superior and inferior lobes. The right lung has two fissures (oblique and horizontal), dividing it into superior, middle, and inferior lobes. Below the lungs, separating the thorax from the abdomen, is a muscular sheet called the diaphragm.

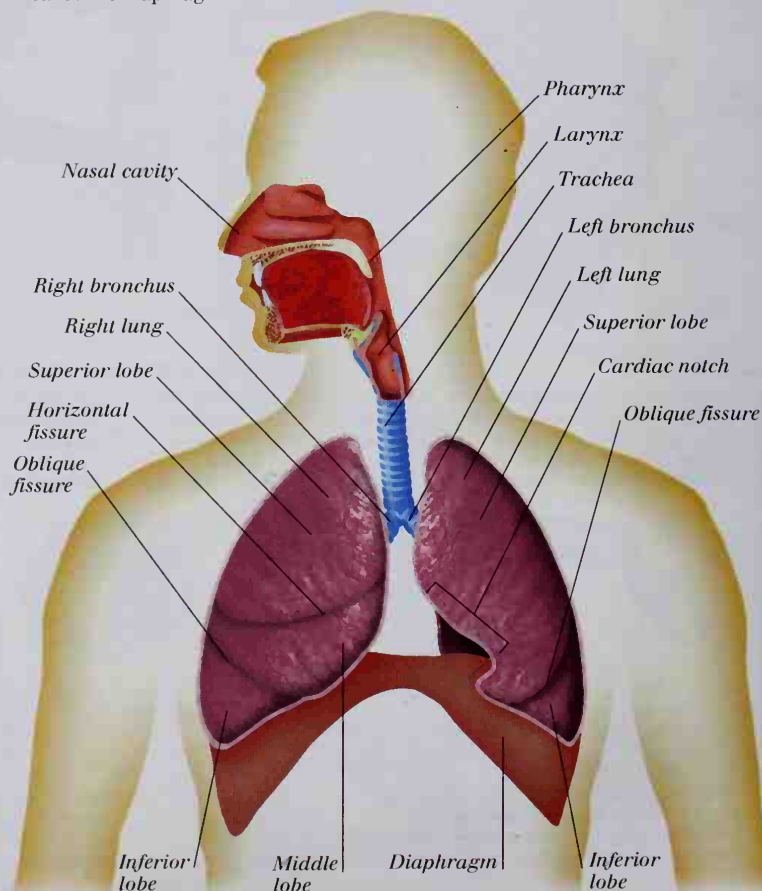

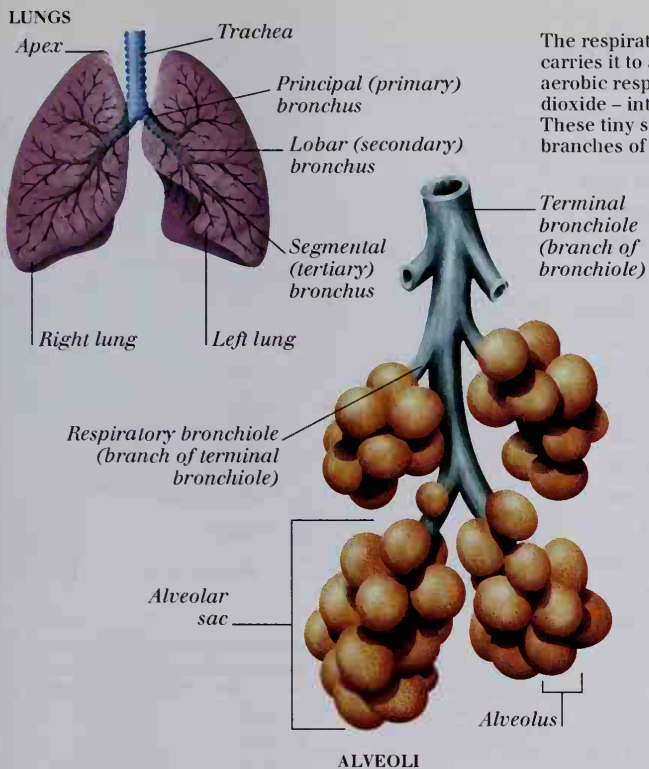

HOW LUNGS WORK

The respiratory system takes oxygen from the air into the bloodstream, and carries it to all body cells, where it is used to release energy from food during aerobic respiration. It also expels the waste product of respiration - carbon dioxide - into the air. The exchange of these gases takes place in the alveoli. These tiny sacs are found at the ends of bronchioles, which are the smallest branches of the lung's network of bronchi.

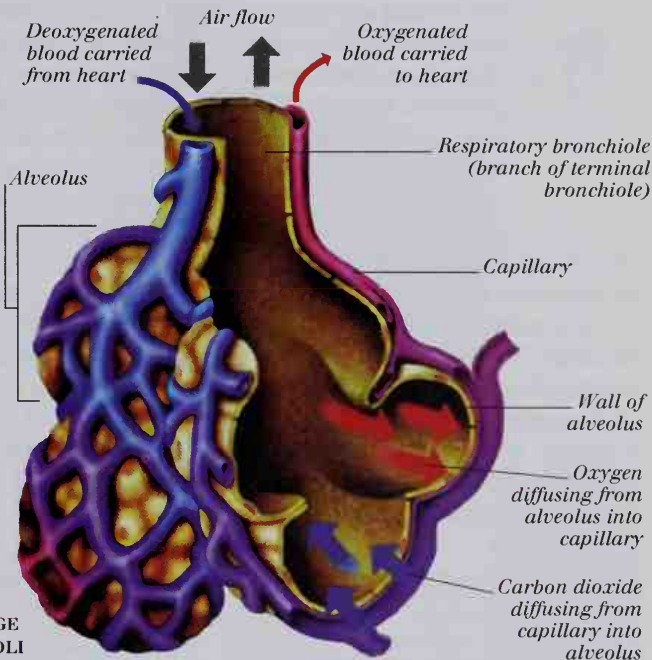

HOW BREATHING WORKS

BREATHING IN

Breathing moves air in and out of the lungs. During breathing in (inhalation), the diaphragm contracts and flattens, increasing the volume and decreasing the pressure inside the thorax, sucking air into the lungs.

BREATHING OUT

The reverse occurs during breathing out (exhalation). The diaphragm relaxes, reducing the volume and increasing the pressure inside the thorax, forcing air out of the lungs.

RIB ACTION

The ribs also play a part in breathing. During inhalation, the intercostal muscles connecting the ribs contract. This lifts the ribs outward and upward, increasing the volume and decreasing the pressure inside the thorax.

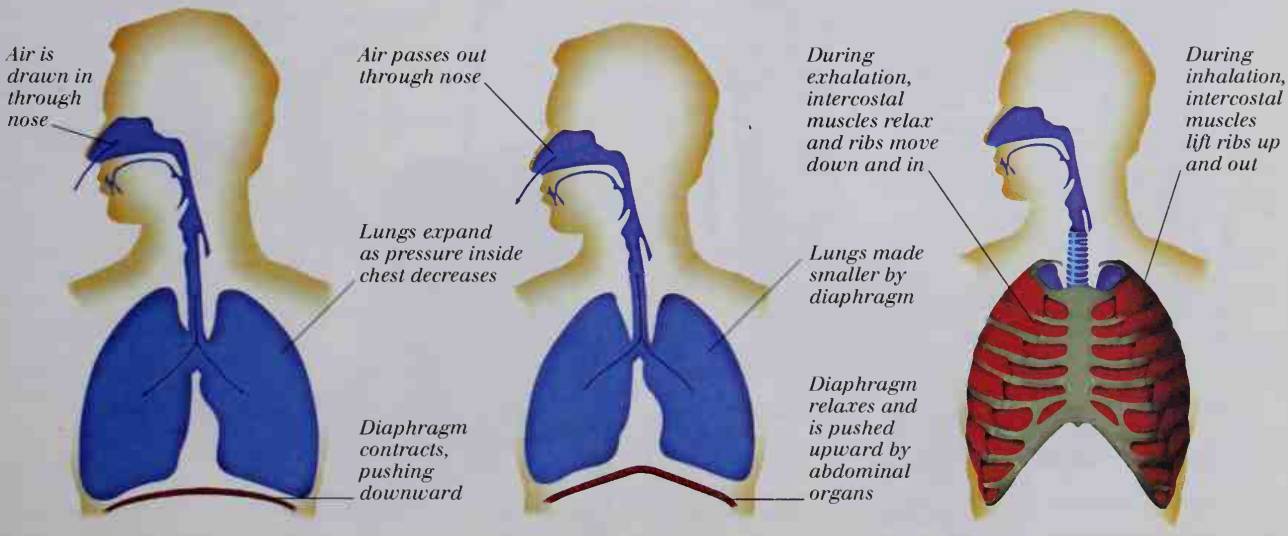

Digestive organs



THE DIGESTIVE ORGANS BREAK DOWN food into small **nutrient molecules** that are used to supply the body's energy needs and the raw materials that are required for growth and repair. Mechanical **digestion**, such as chewing, breaks down food by physical action; chemical digestion uses digesting agents called **enzymes** to break down food particles even further. Food ingested through the mouth is cut and ground by the teeth, lubricated with **saliva**, pushed by the tongue into the pharynx, where it is swallowed, and squeezed down the esophagus into the stomach by muscular action. Here, mechanical and chemical digestion occur, producing a souplike fluid that is released into the small intestine. The digestive process is completed here, assisted by enzyme-containing secretions from the pancreas, as well as **bile** produced in the liver. Digested food is then absorbed through the small intestine wall into the bloodstream. The large intestine absorbs most of the remaining water from undigested food, which is eliminated through the anus as feces.

SALIVARY GLANDS

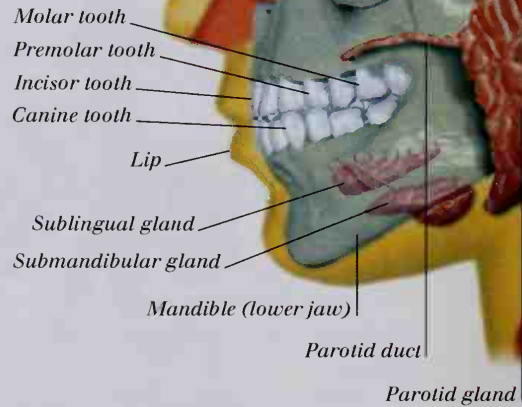

There are three pairs of salivary glands that release saliva into the mouth through ducts, especially during eating. Saliva moistens and lubricates food, and digests starch.

SWALLOWING

Swallowing, the sequence of movements that takes food from mouth to stomach, has two phases. In the first, the tongue forces the bolus (ball) of chewed-up food backward into the pharynx.

PHASE 1

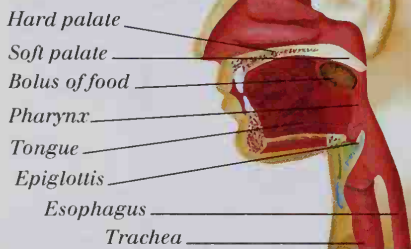

In the second, reflex (automatic) phase, the epiglottis closes to stop food going into the trachea; the soft palate blocks the entrance to the nasal cavity; and throat muscles push the food bolus into the esophagus.

PHASE 2

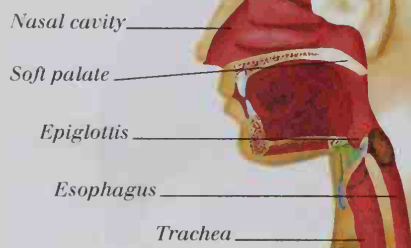

THE DIGESTIVE SYSTEM

The digestive system has two parts: the alimentary canal, formed by the mouth, pharynx (throat), esophagus, stomach, and small and large intestine; and the accessory organs, formed by the salivary glands, teeth, tongue, liver, gallbladder, and pancreas.

LIVER AND GALL BLADDER

The liver produces bile, which is stored in the gall bladder and emptied into the duodenum to help digest fats.

THE PANCREAS

The pancreas produces digestive enzymes. These are released into the duodenum in the pancreatic juice, through the pancreatic duct.

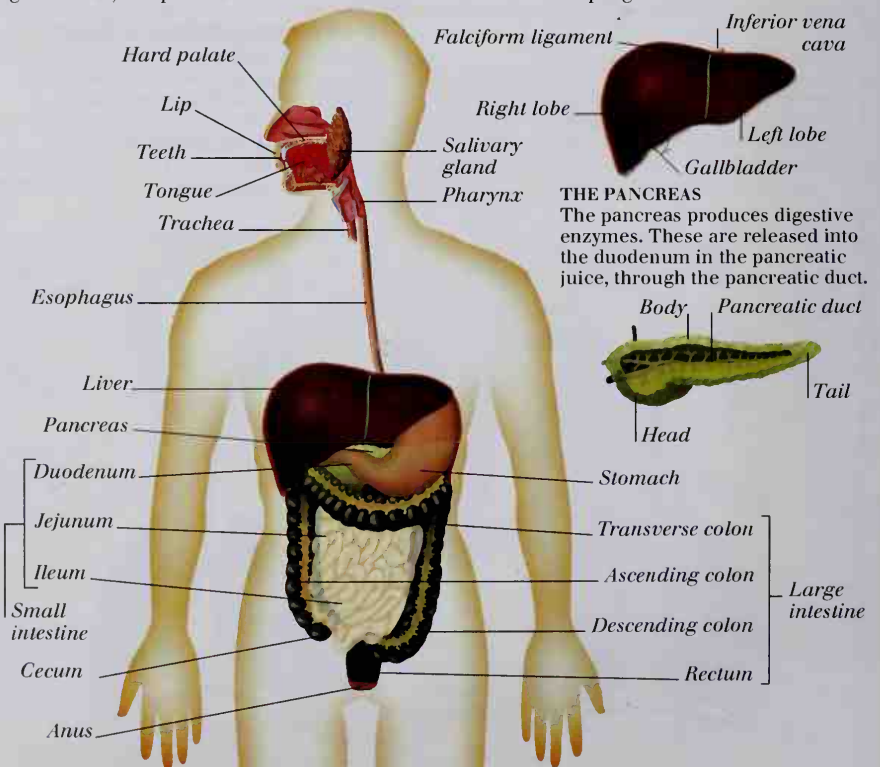

TEETH

Teeth cut and crush food so that it can be swallowed and digested more easily. A tooth has an outer layer of hard enamel, overlying a layer of bonelike dentine, which encloses the pulp cavity.

MOLAR TOOTH

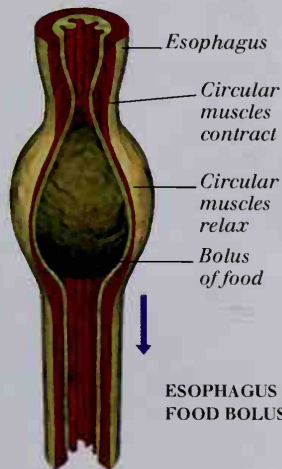
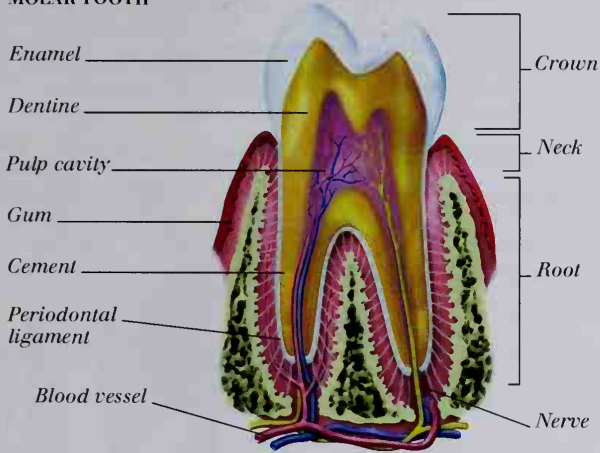

PERISTALSIS

This is the process that moves food along the alimentary canal toward the stomach. After swallowing, for example, the circular muscle that surrounds the esophagus contracts behind the food, but relaxes in front of it. As this powerful wave of contraction moves toward the stomach, it pushes the food forward.

ESOPHAGUS WITH FOOD BOLUS

THE STOMACH

The stomach stores food for several hours, during which time its muscular wall contracts to churn up food, and its digestive juices work to break down proteins. This partially digests food into a souplike liquid, which is then released into the duodenum.

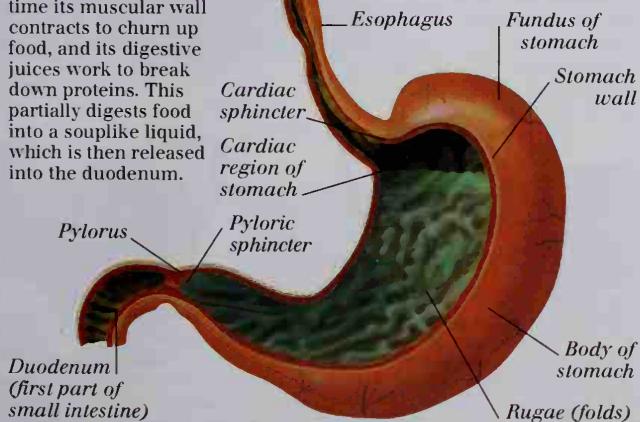

INTERIOR VIEW OF STOMACH

THE SMALL INTESTINE

This is the part of the alimentary canal where digestion is completed with the aid of enzymes secreted by the intestinal wall. Microscopic projections called villi give the small intestine wall a larger surface area to make the absorption of food more efficient.

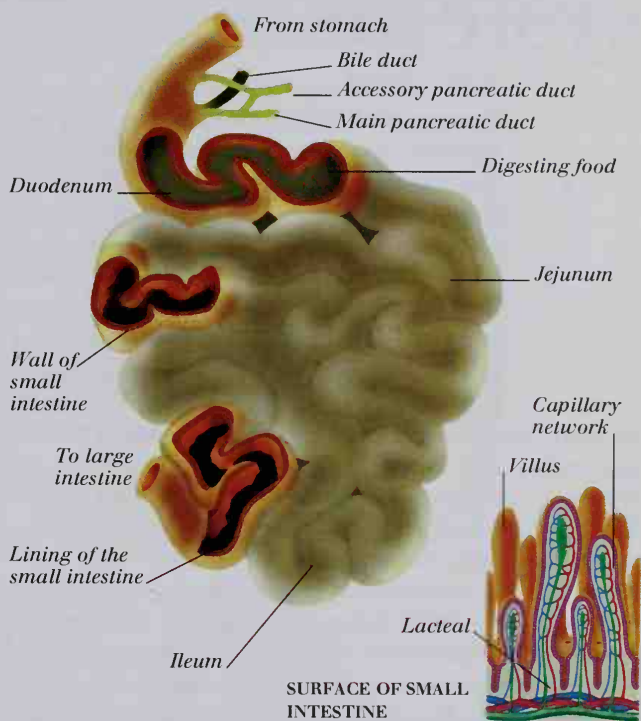

SURFACE OF SMALL INTESTINE

THE LARGE INTESTINE

This carries undigested waste out of the body. Water is absorbed from liquid waste as it passes through the colon, leaving only solid feces. These are stored in the rectum before being released through the anus.

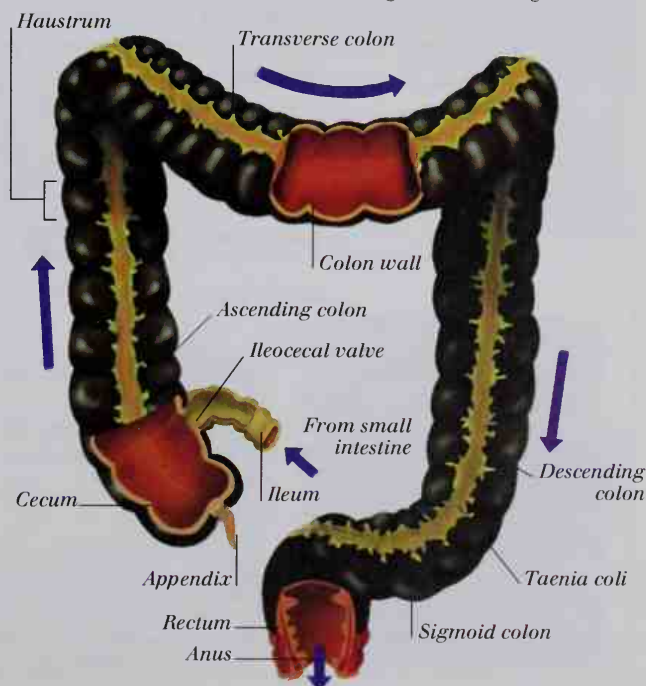

Urinary and reproductive systems



THE URINARY SYSTEM, which consists of the urinary bladder, ureters, urethra, and kidneys, produces **urine**, a waste liquid, and transports it out of the body. Urine forms as the two kidneys remove all water and salts excess to the body's requirements, along with urea (a waste substance produced by the liver), and other poisonous wastes from the blood. It flows down the ureters to the muscular bladder which, when full,

gently squeezes the urine out of the body through the urethra. The reproductive system works by generating and transporting male and female sex cells (sperm or ova) with the purpose of producing offspring. The male reproductive system consists of two sperm-producing testes, the vasa deferentia (sing. vas deferens), the urethra and **erectile penis**, and semen-producing glands, including the prostate. The female reproductive system consists of two ovaries, which alternately release one ovum (egg) each month, the fallopian tubes, the uterus, and the vagina. The male and female reproductive systems are brought together when the erect penis is placed inside the vagina during sexual intercourse. Sperm, activated by semen, are transported along the vasa deferentia and ejaculated from the penis. They then swim through the uterus and fertilize an ovum, if present, in the fallopian tubes.

THE URINARY SYSTEM

Daaily, over a million filtration units called nephrons, found in the kidney's medulla and cortex, process up to 180 liters (39.5 gallons) of fluid from blood to produce about 1.5 liters (2.6 pints) of urine. This passes down the ureter and is stored in the bladder.

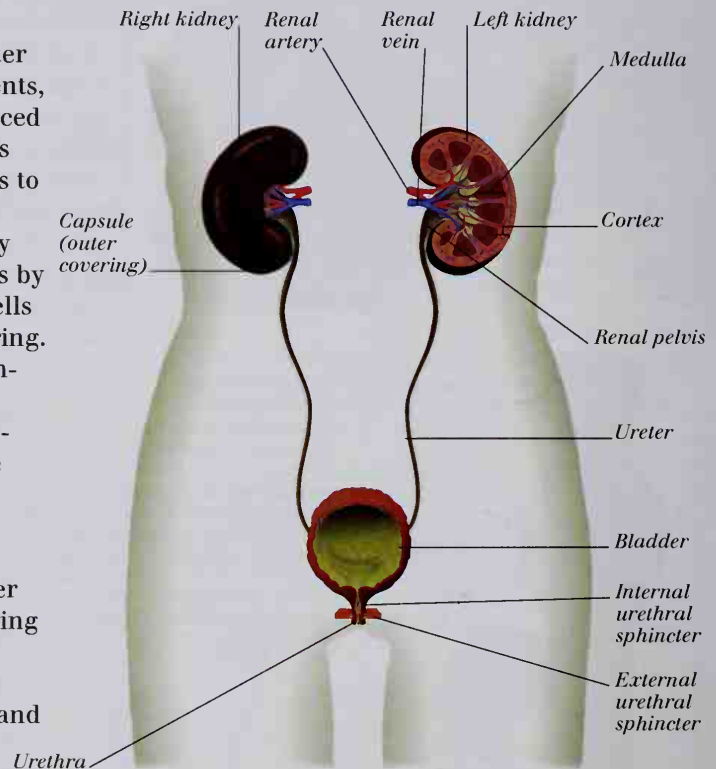

THE BLADDER

As the bladder fills with urine, it expands and triggers a conscious urge to urinate. The two sphincters (muscle rings) are relaxed, the bladder contracts rhythmically, and urine is expelled along the urethra.

BLADDER FILLING

Bladder wall thins and stretches upward and outward as urine collects.

BLADDER EMPTYING

Bladder wall thickens and folds as bladder empties.

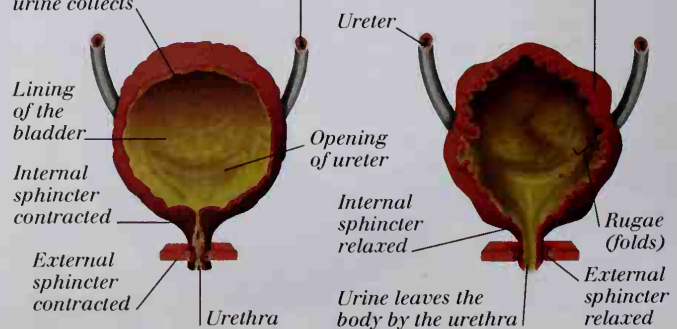

HOW KIDNEYS WORK

Tiny blood-processing units (nephrons) collect fluid from the blood through Bowman's capsules. Useful substances are reabsorbed into the blood as the fluid passes through the tubules. When it reaches the collecting duct, it contains only waste (urine).

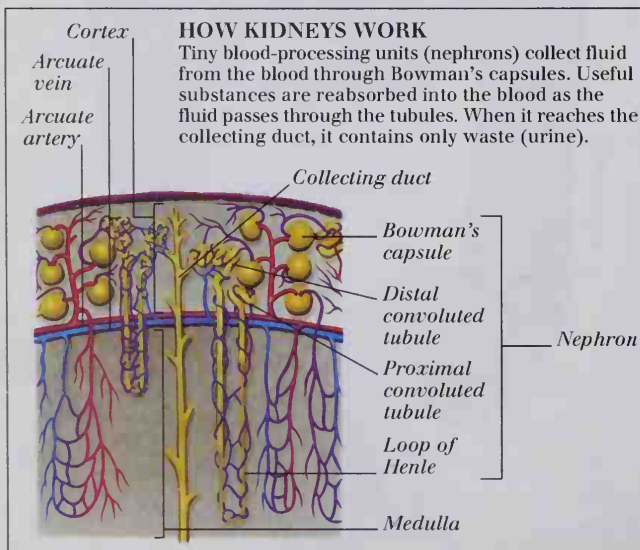

REPRODUCTIVE ORGANS

FEMALE REPRODUCTIVE ORGANS

Each month, one ovary releases an ovum and the endometrium (lining of the uterus) thickens in preparation to receive the ovum, should it be fertilized in the fallopian tube on its way to the uterus. The vagina is the canal through which sperm enter a woman's body, and through which a baby is born.

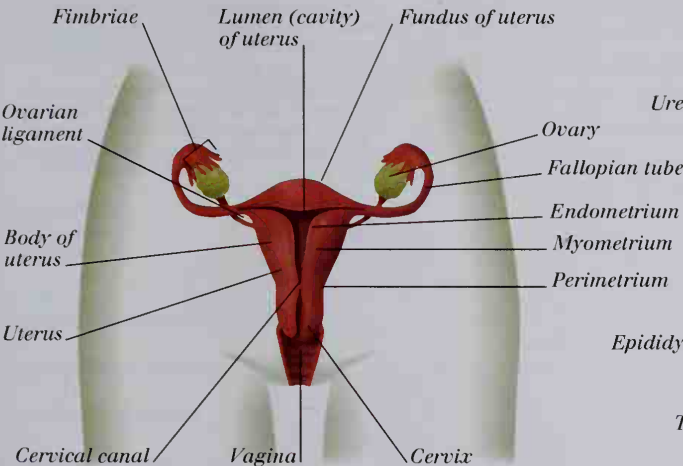

MALE REPRODUCTIVE ORGANS

The testes produce millions of sperm each day. On their way to the penis along the vasa deferentia (sing. vas deferens), sperm are mixed with fluid from the seminal vesicles and prostate gland to form semen. The penis contains spongy tissue that fills with blood before sexual intercourse, making the penis erect.

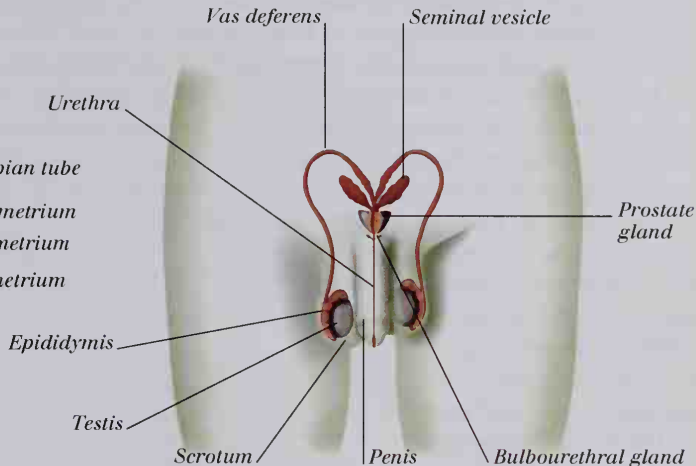

HOW REPRODUCTION WORKS

SEXUAL INTERCOURSE

Sexual intercourse (coitus) is the act that brings male and female sex cells into contact. When a couple becomes sexually aroused, a man puts his erect penis inside his partner's vagina. As they move together, the man ejaculates, releasing semen into the vagina. Sperm in the semen swim through the cervix, into the uterus, and up to the fallopian tubes.

FERTILIZATION OF THE OVUM

The union of the ovum with a single sperm produces a zygote (fertilized ovum) that will develop into a baby in the uterus. For fertilization to occur, sperm must reach the ovum within 24 hours of its release from the ovary.

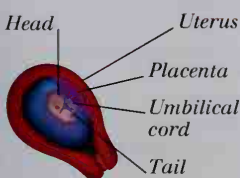
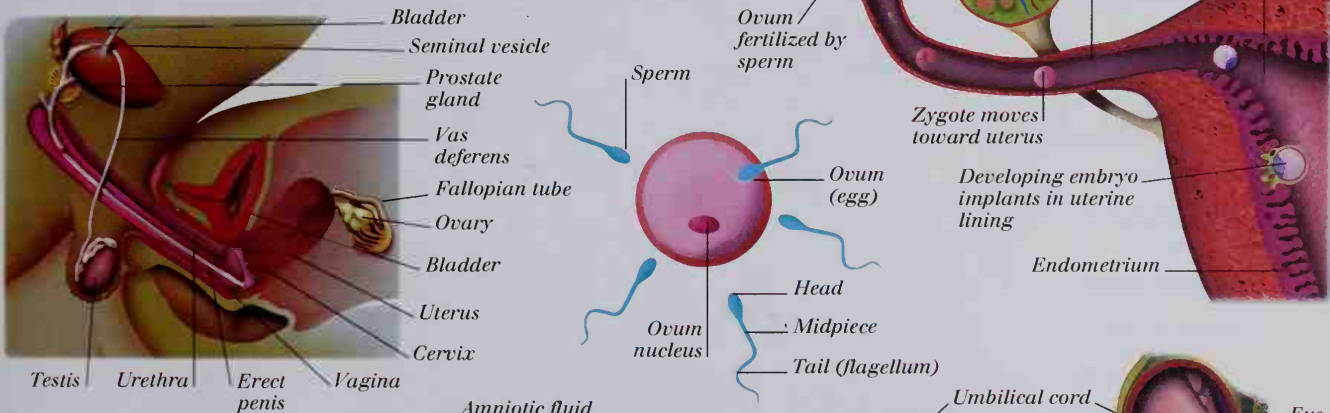

SIX-WEEK-OLD EMBRYO

For its first eight weeks inside the uterus, the developing baby is called an embryo. At six weeks, the apple-seed-sized embryo has limb buds, a simple brain, and eyes. It obtains food and oxygen from its mother through the placenta and umbilical cord.

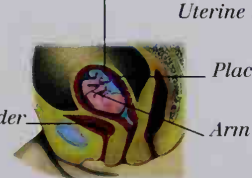
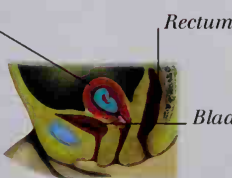

12-WEEK-OLD FETUS

At 12 weeks, the developing baby, now called a fetus, has tiny fingers and toes. Amniotic fluid protects it from external shocks.

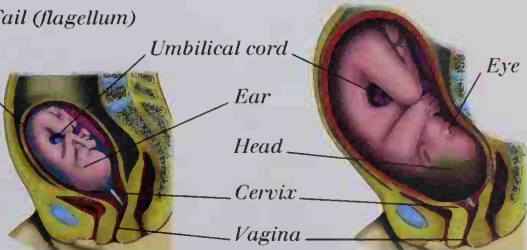

22-WEEK-OLD FETUS

By week 22, the fetus is recognizably human, with its major body systems in place. Its kicking movements can be felt by the mother.

FULL-TERM FETUS

The fetus is fully developed and ready to be born. During the birth, the cervix widens, and the uterus muscles contract to push the baby out of the vagina.

Head and neck 1

THE HEAD CONTAINS THE BRAIN – the body’s control center – and major sense organs. Its framework is provided by the skull, which is made up of the cranium and the facial bones. The cranium encloses and protects both the brain and the organs of hearing and balance. The facial bones form the face and provide the openings through which air and food enter the body. They also contain the organs of smell and taste, hold the teeth in place, house and protect the eyes, and provide attachment points for the facial muscles. The neck supports the head and provides a conduit for communication between the head and trunk. Blood is carried to and from the head by the carotid arteries and jugular veins. The spinal cord, which links the brain to the rest of the nervous system, runs protected within a tunnel formed by the cervical vertebrae. The trachea (windpipe) carries air between the pharynx (throat) and lungs. The esophagus transports food from the pharynx to the stomach.

SUPERFICIAL AND DEEP FACIAL MUSCLES

These muscles produce the wide range of facial expressions that communicate thoughts and emotions. These muscles include the frontalis, which wrinkles the forehead; the orbicularis oculi, which causes blinking; the risorius, which pulls the edge of the lip sideways into a smile; and the depressor labii inferioris, which pulls the lower lip downward into a pout.

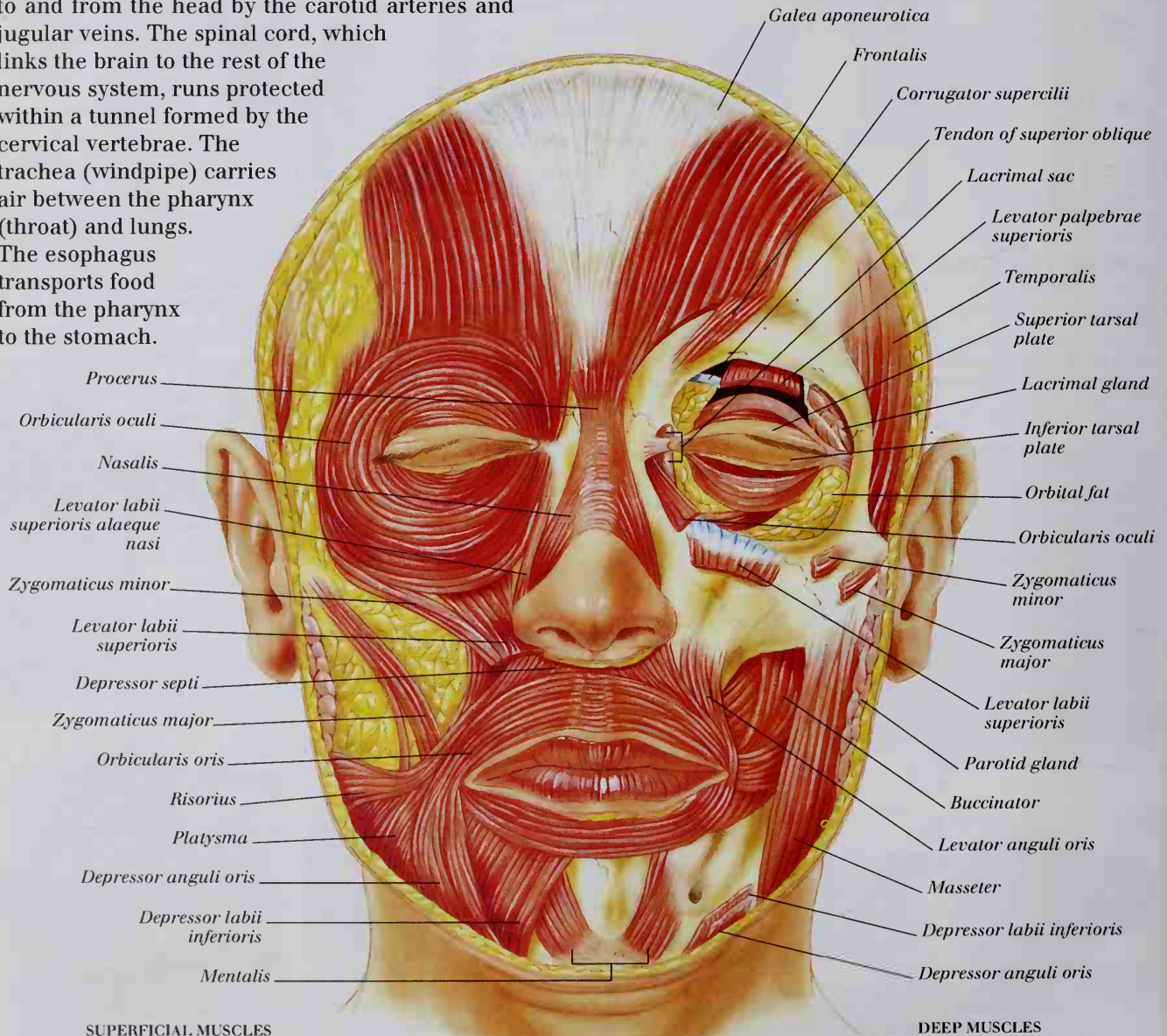

MUSCLES OF THE HEAD AND NECK

Two muscles located on each side of the head, the masseter and temporalis, close the jaw by pulling the mandible upward. The deeper buccinator (cheek muscle) keeps food between the teeth during chewing. The larger neck muscles (the sternocleidomastoid and the splenius capitis) support and move the head.

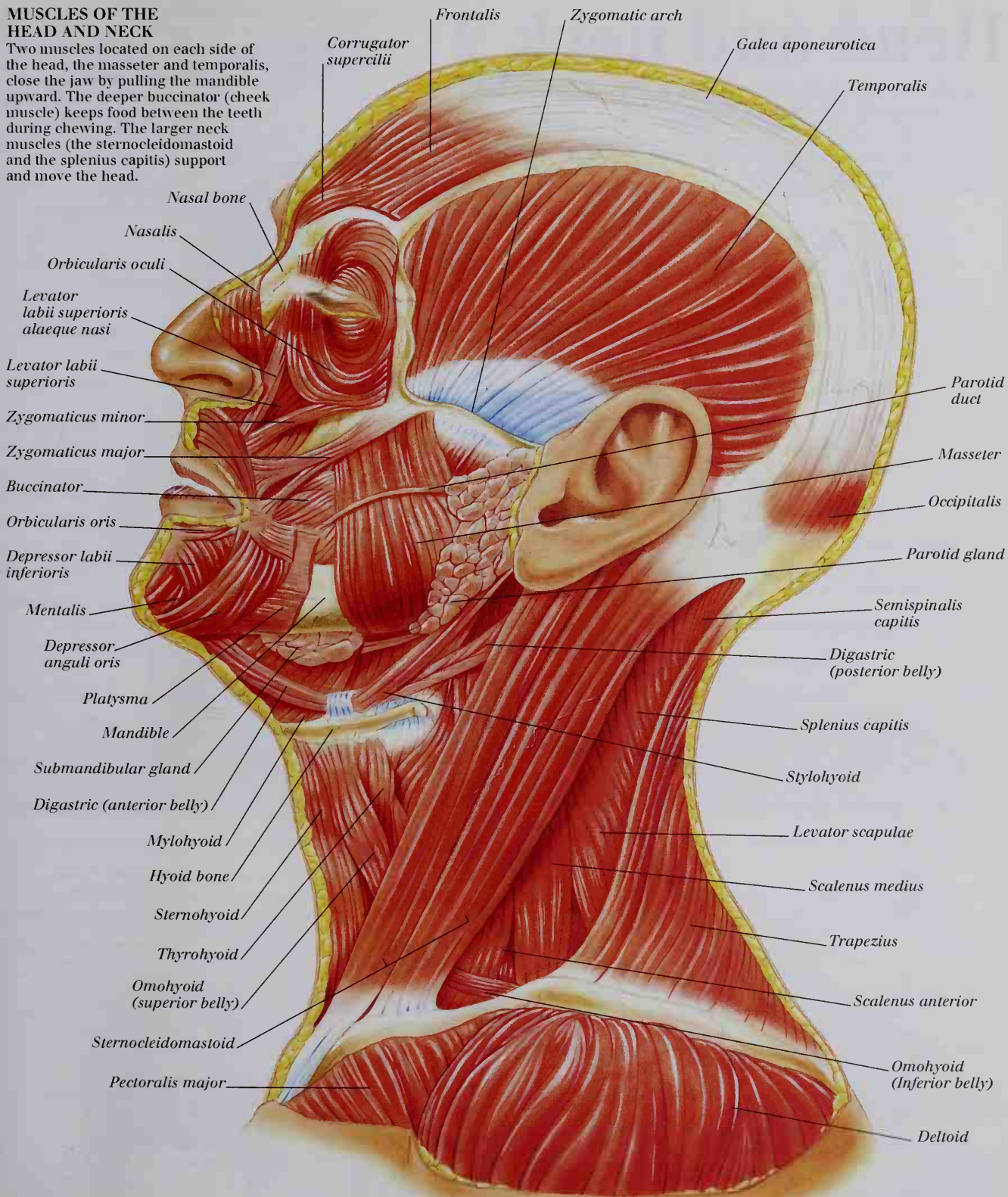

Head and neck 2

SUPERFICIAL MUSCLES, NERVES, AND BLOOD VESSELS

Branches of the facial nerve supply the muscles of facial expression, such as the risorius. Blood is supplied to most parts of the head by branches of the external carotid arteries and internal jugular veins. These include the superficial temporal, and facial arteries and veins.

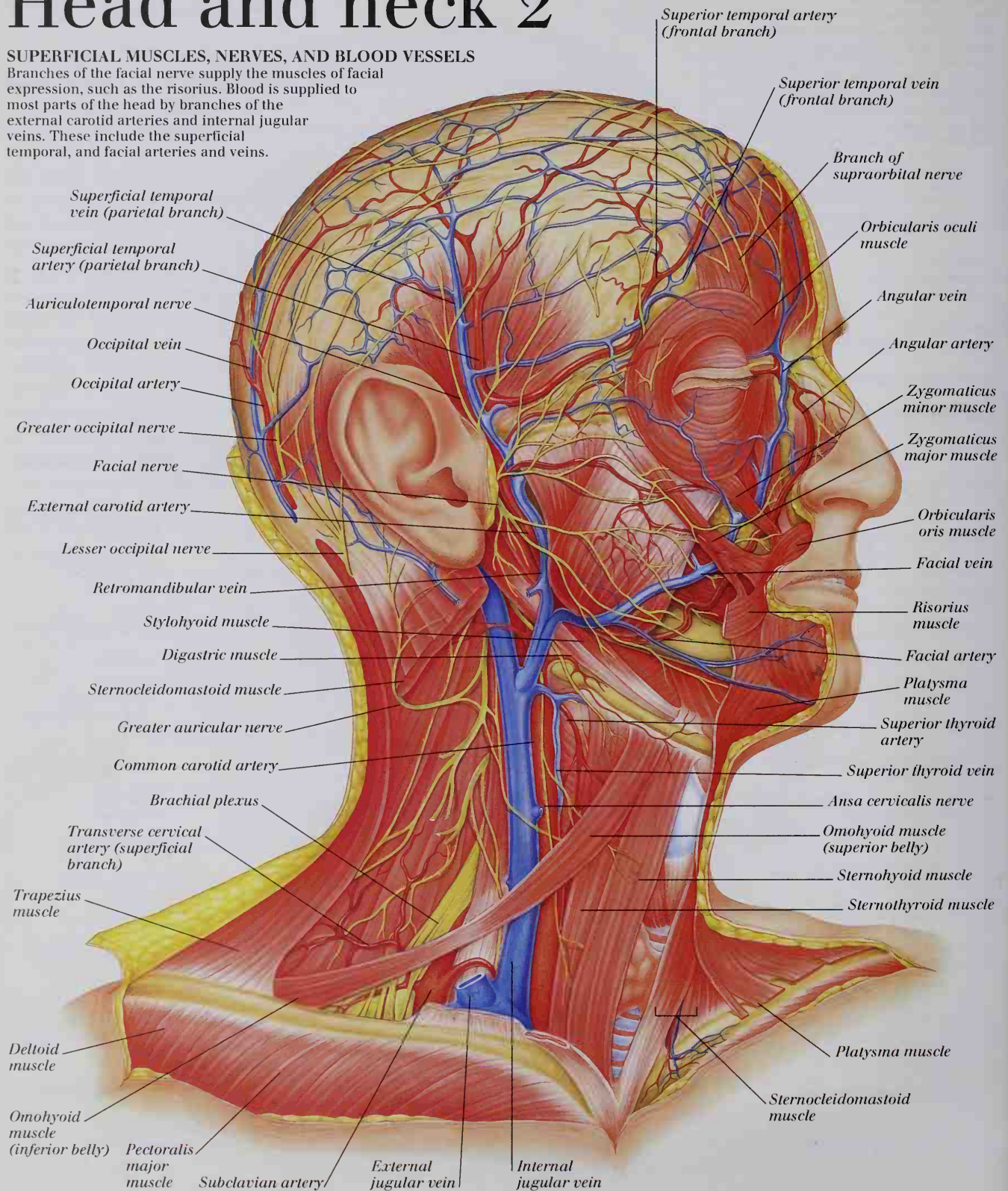

POSTERIOR VIEW OF THE NECK AND HEAD

The head is balanced on top of the vertebral column. The muscles of the posterior of the neck, such as the splenius capitis and semispinalis capitis, assisted by the trapezius, support the head by pulling it back to prevent it from falling forward.

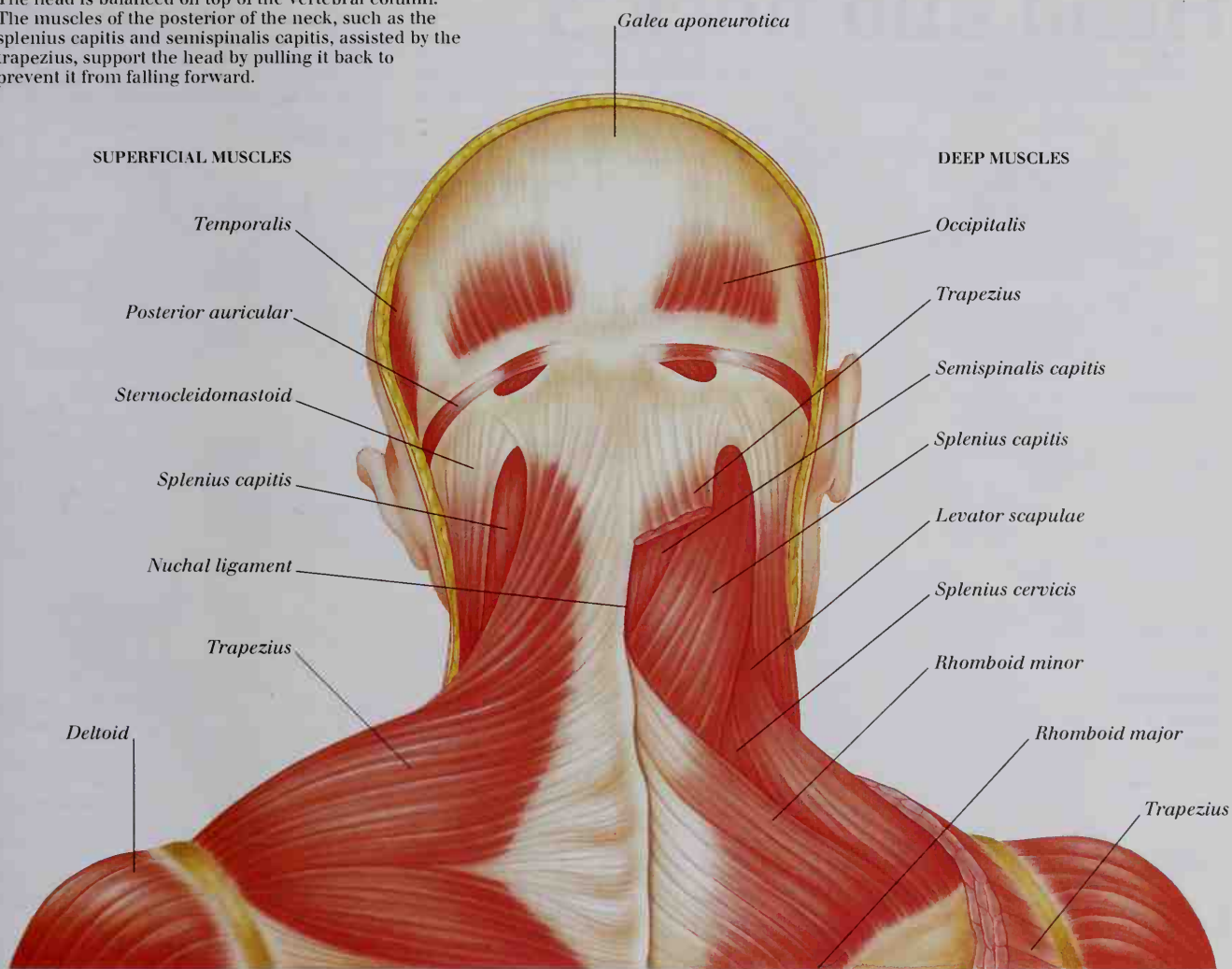

ANATOMY OF THE EAR, NOSE, AND EYE

EAR

The middle section of the ear is traversed by three small bones, which carry sounds to the cochlea, where they are converted into nerve impulses and then carried to the brain for interpretation.

NOSE

The framework of the external nose has a bony part, consisting mainly of the nasal bones, and a more flexible cartilaginous part, consisting of the lateral, septal, and alar cartilages.

EYE

The spherical eyeball consists of a tough outer layer (the sclera) with a clear cornea at the front. It is moved up and down, and from side to side by four rectus and two oblique muscles.

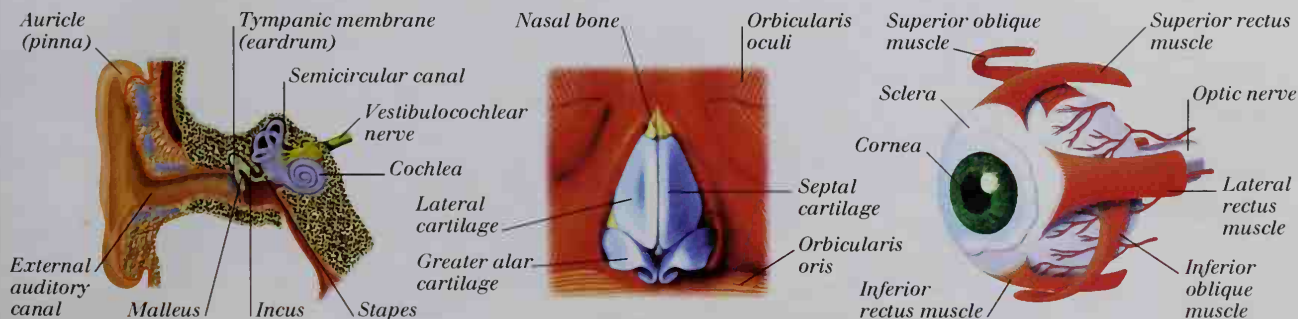

Head and neck 3

LATERAL VIEW OF HEAD AND NECK
 The removal of the skull bones reveals three sense organs: the eye, nasal cavity, and tongue. The muscles of the neck rotate the head and bend it to the side. The epiglottis closes the entrance to the trachea during swallowing to stop food from entering it.

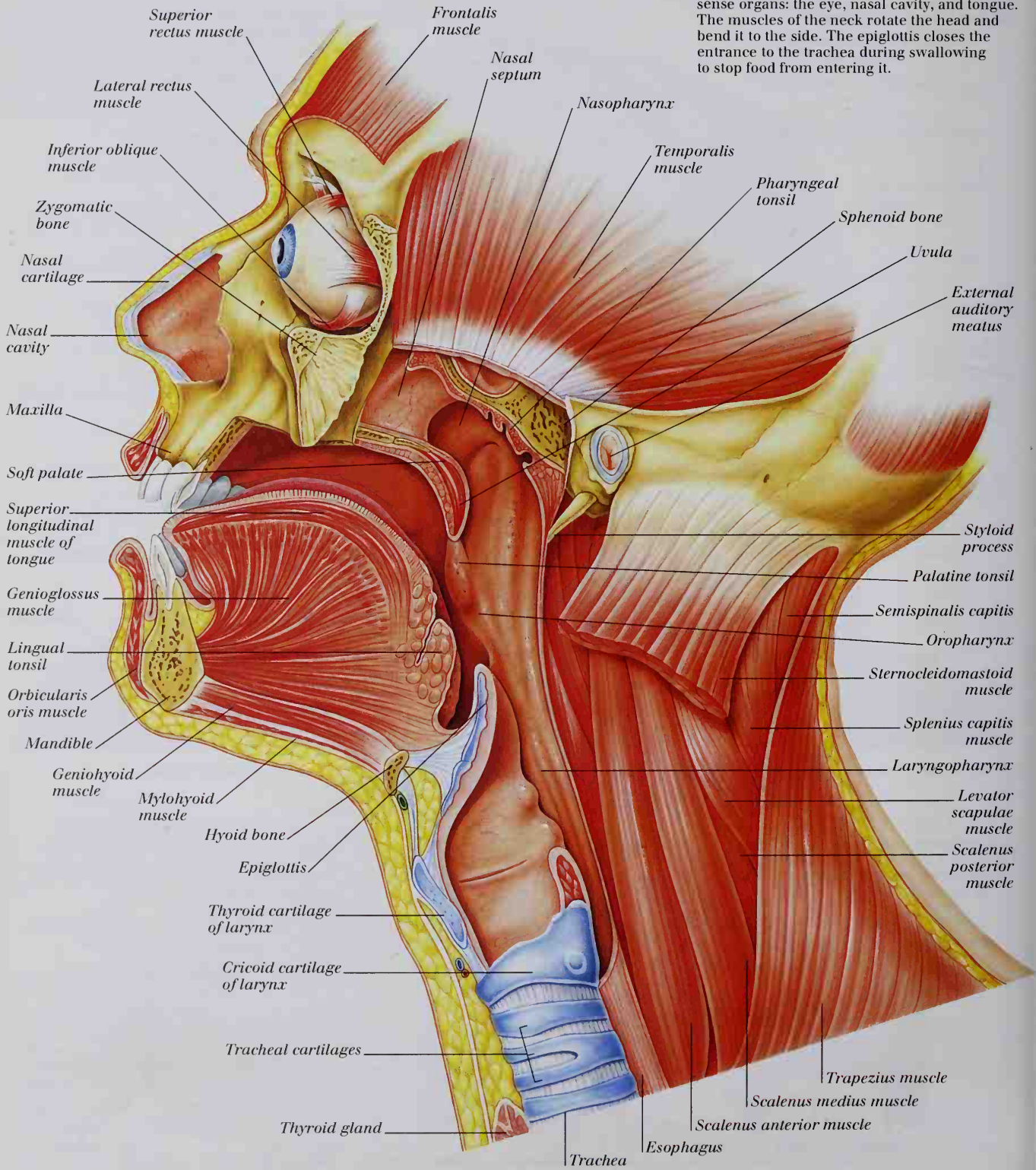

HOW THE NOSE, TONGUE, AND EYE WORK

NOSE
The nose is used for breathing and smelling. Smell receptors in the olfactory epithelium, which lines the upper nasal cavity, detect odor molecules in the air passing over them.

TONGUE
The tongue is a muscular organ used to swallow and taste food. Tastes are detected by taste buds located on papillae, protuberances on the tongue.

EYE
The eye enables us to see our surroundings. Light enters, and is focused by, the cornea and lens, and is detected by sensors in the retina, which send nerve impulses to the brain.

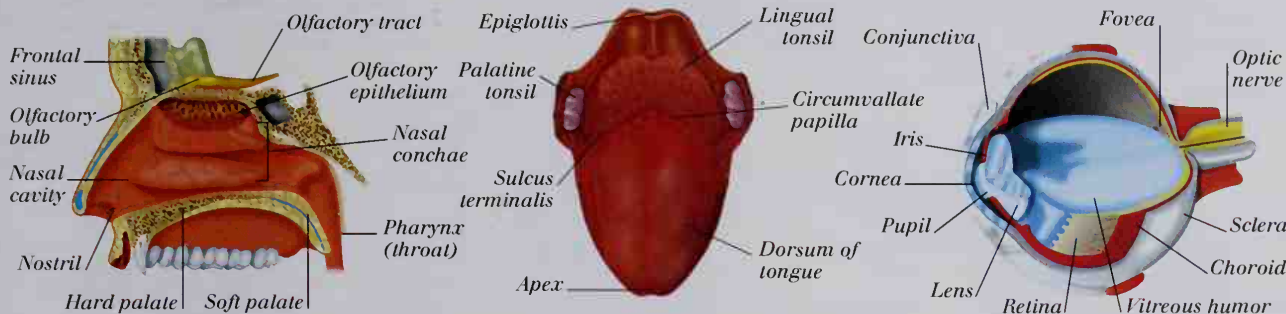

ANTERIOR VIEW OF NECK
Most anterior neck muscles, including the omohyoid, sternohyoid, digastric, thyrohyoid, and mylohyoid, are involved in the movements that occur during swallowing.

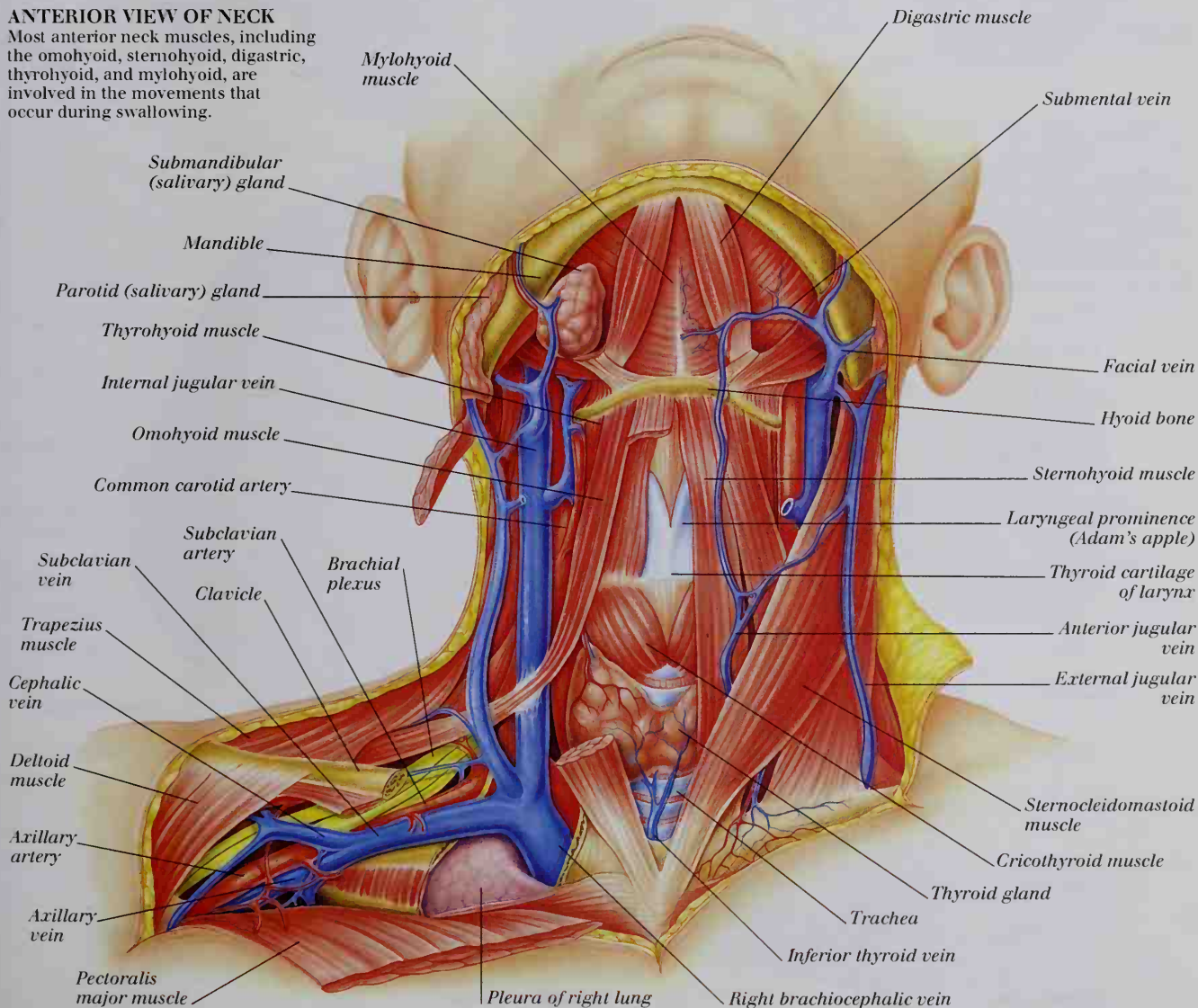

Head and neck 4

ANTERIOR VIEW OF SKULL

The skull is made up of 22 bones. Cranial bones, such as the frontal bone, form the helmetlike cranium; facial bones, such as the maxilla, form the face.

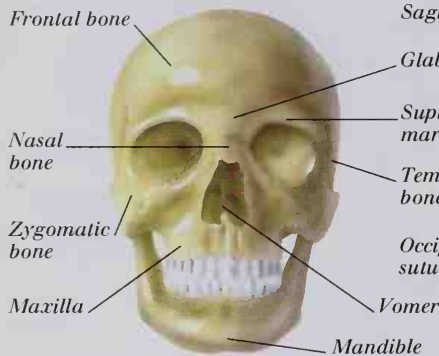

POSTERIOR VIEW OF SKULL

Skull bones, apart from the mandible (lower jaw), are fused together at interlocking joints called sutures, which stop the bones from moving.

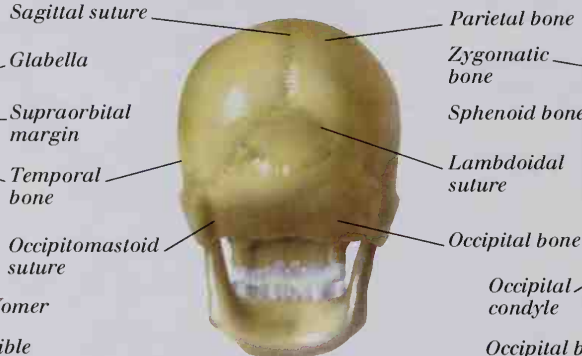

INFERIOR VIEW OF SKULL

The foramen magnum is a large hole through which the brain connects to the spinal cord. The occipital condyles form a joint with the top of the backbone.

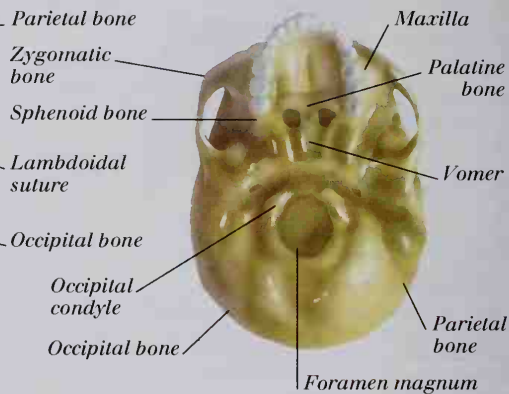

LATERAL VIEW OF SKULL AND BRAIN

The cerebrum is the largest part of the brain. Its surface is folded into ridges called gyri (sing. gyrus) and separated by grooves called sulci (sing. sulcus). It is divided into left and right cerebral hemispheres. Deep sulci divide each hemisphere into five lobes.

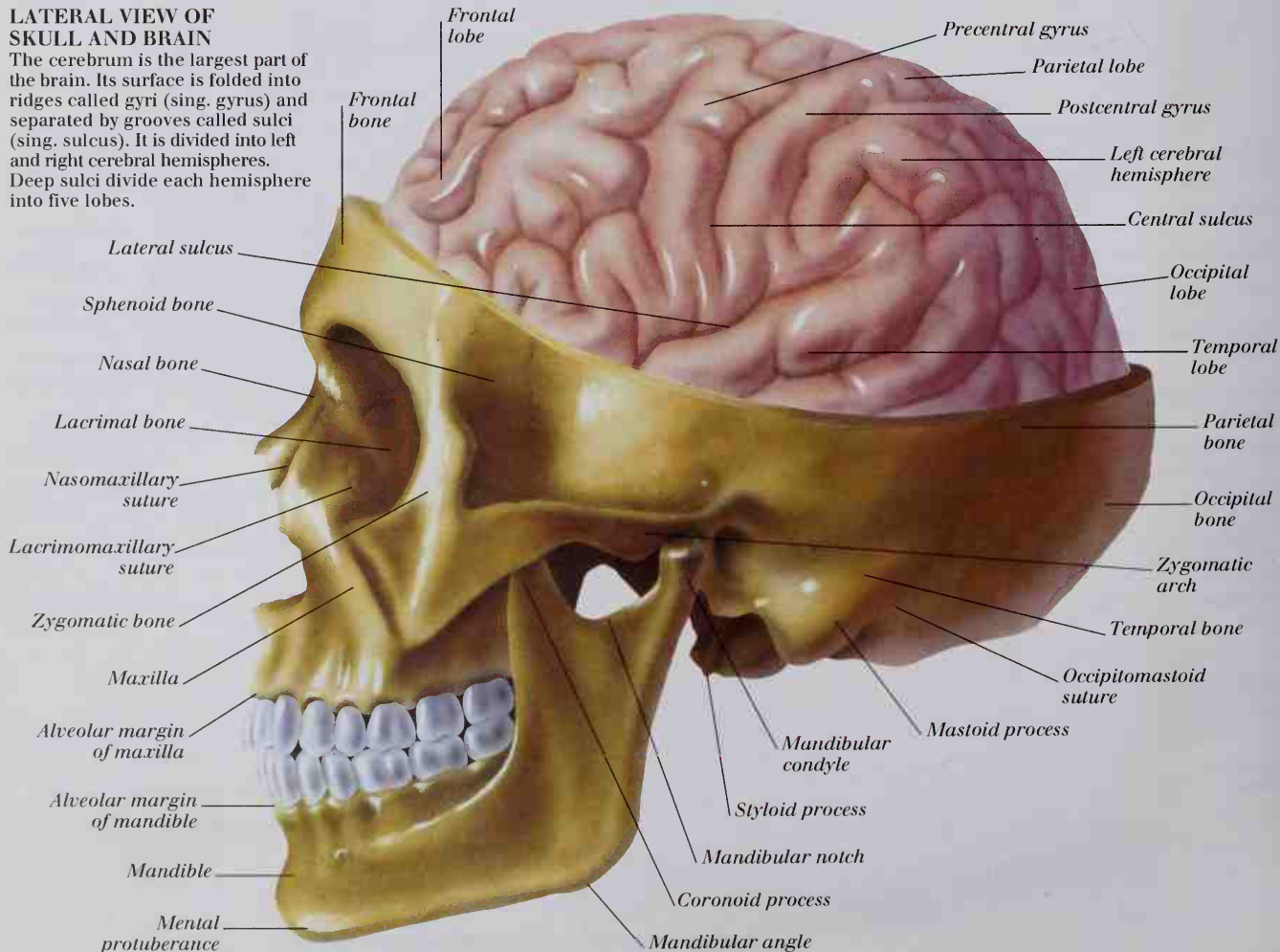

CORONAL SECTION OF BRAIN

Each cerebral hemisphere consists of gray matter, where conscious thought takes place, and white matter, made up of a communication network of nerve fibers. Ventricles are spaces filled with cerebrospinal fluid, which protects and nourishes the brain.

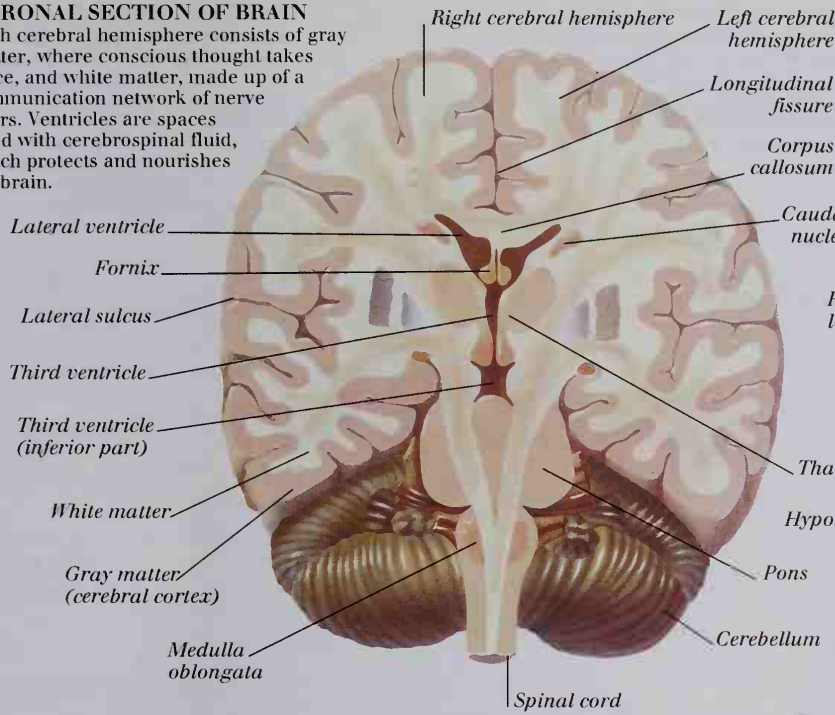

SAGITTAL SECTION OF BRAIN

This section shows the corpus callosum, which links the left and right cerebral hemispheres; the cerebellum, which coordinates balance and movement; the brain stem, which controls automatic functions such as breathing; and the thalamus, which sorts and filters nerve impulses traveling to the cerebrum.

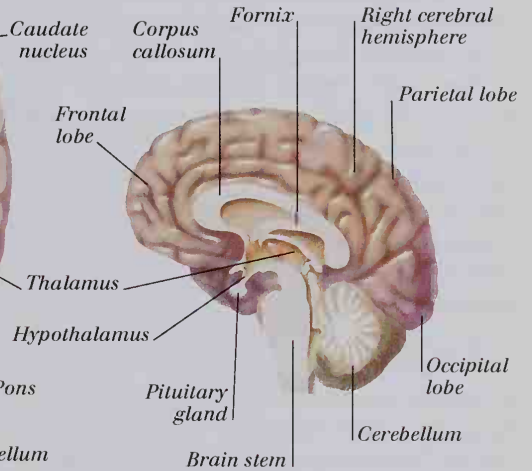

INFERIOR VIEW OF BRAIN

From below, the cranial nerves – nerves that arise from the brain – can be seen. These include the olfactory tract, from the nose; the optic nerve, from the eyes; and the vagus nerves, which supply the heart, lungs, and abdominal organs.

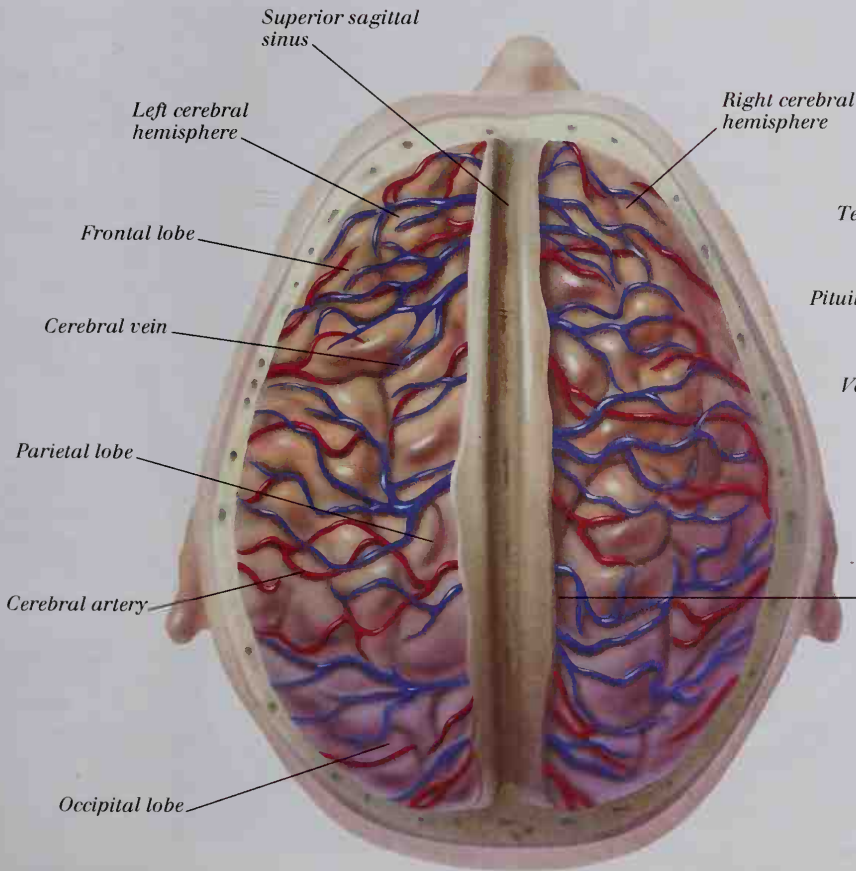
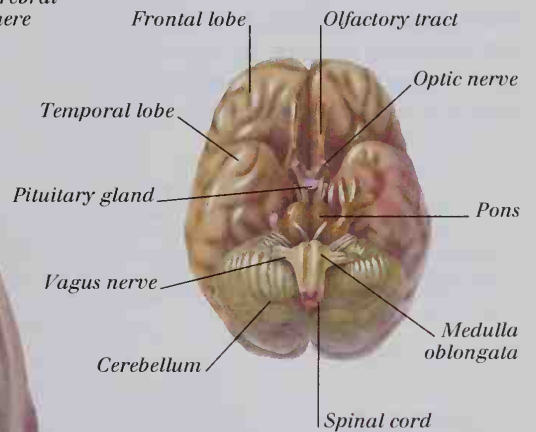

SUPERIOR VIEW OF BRAIN

Oxygen-rich blood from the heart is distributed to all parts of the cerebral hemispheres by the cerebral arteries. Oxygen-poor blood, removed from the hemispheres by the cerebral veins, empties into the superior sagittal sinus on its return journey to the heart.

Trunk 1

THE TRUNK, OR TORSO, IS THE CENTRAL part of the body, to which the head, arms, and legs are attached. It is divided into an upper thorax, or chest, and a lower abdomen. Major superficial muscles of the anterior trunk include the pectoralis major, which pulls the arm forward and inward, and the external oblique, which holds in the contents of the abdomen and flexes the trunk. Major deep muscles include the external intercostals, which move the ribs upward during breathing, and the rectus abdominis, which flexes the lower back. Women have breasts – soft, fleshy domes that surround the mammary glands overlying the pectoralis major muscle. Each breast consists of lobes of milk-secreting glands, which are supported by ligaments and embedded in fat, with ducts that open out of the body through the nipple. Major superficial muscles of the posterior trunk include the trapezius, which stabilizes the shoulder, and the latissimus dorsi, which pulls the arm backward and inward. Major deep muscles include the rhomboid minor and rhomboid major, which “square the shoulders.” The trunk has a bony axis, which is known as the vertebral column, or spine. Spinal nerves emerge from the spinal cord, which is protected within the spine.

LATERAL VIEW OF SUPERFICIAL MUSCLES

The lateral view of the trunk shows two powerful muscles that act as antagonists (work in opposite directions to each other): the latissimus dorsi, which extends the arm, pulling it backward, and the pectoralis major, which, assisted by the biceps brachii, flexes the arm and pulls it forward.

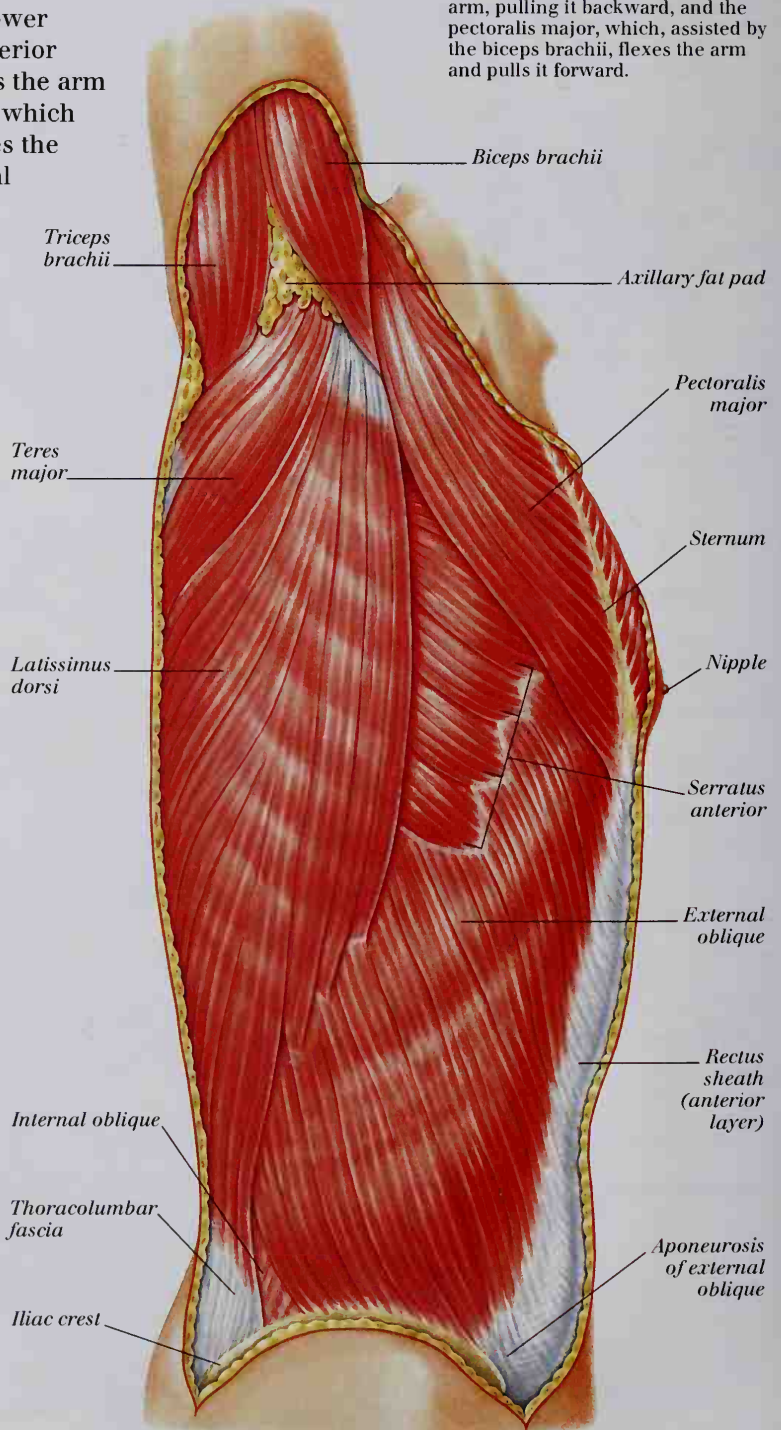

SAGITTAL SECTION OF LEFT BREAST

After a baby is born, a woman begins to produce milk (lactate). This is produced by the glands in the lobules, and accumulates in the lactiferous sinuses. It is released from the sinuses through the lactiferous ducts when the baby sucks on the nipple.

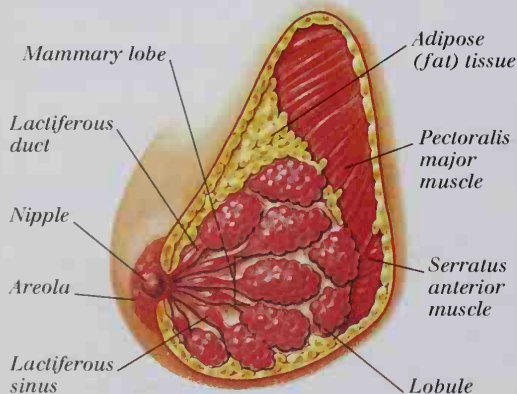

ANTERIOR VIEW OF SUPERFICIAL AND DEEP MUSCLES

While the upper trunk is supported by the bony framework of the rib cage, the walls of the abdomen are formed solely by broad, flat muscles. The flattened tendons (aponeuroses) of these muscles fuse medially to form the linea alba. If not well-toned, the abdominal muscles sag outward, forming a "pot belly."

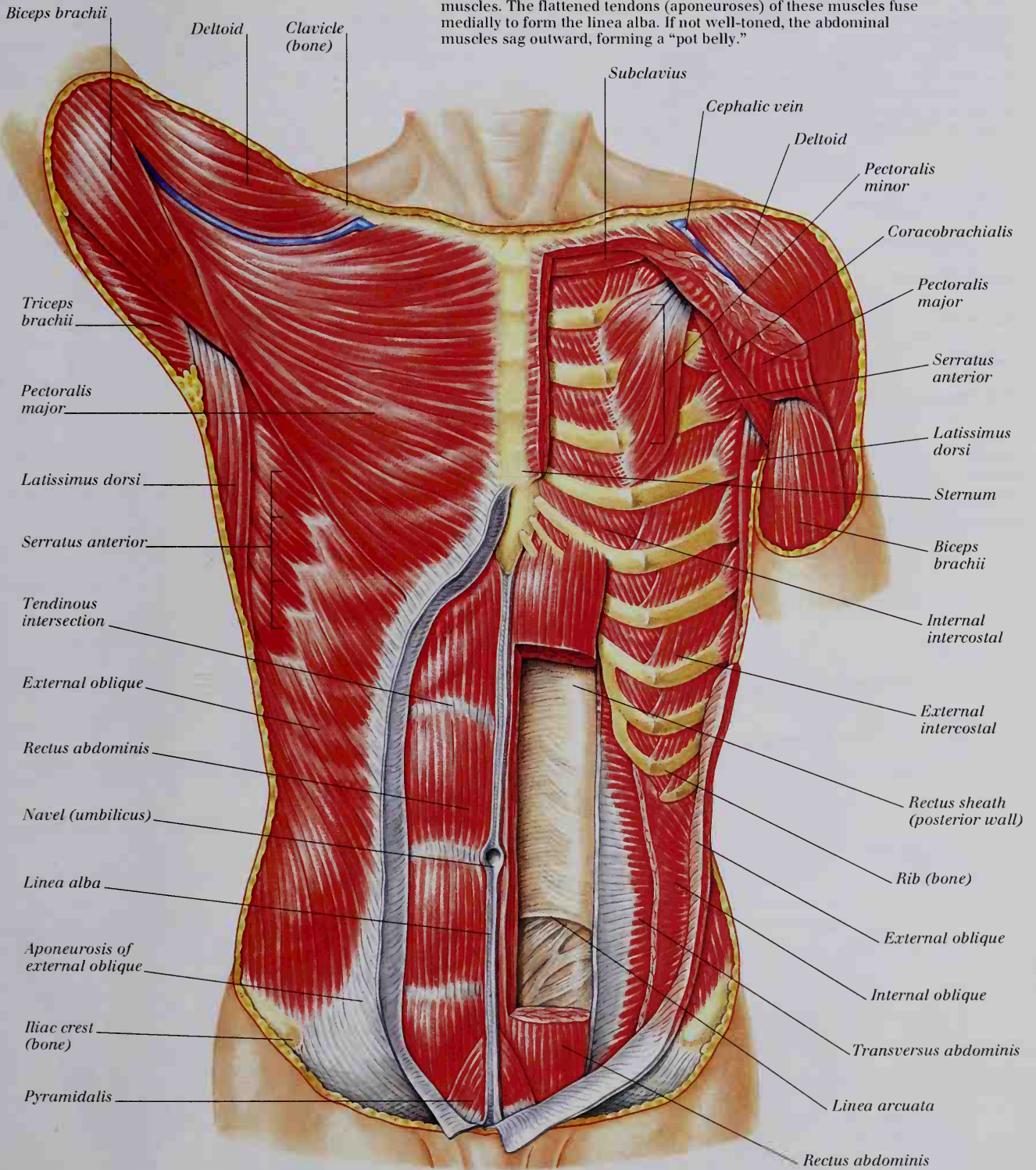

SUPERFICIAL MUSCLES

DEEP MUSCLES

Trunk 2

POSTERIOR VIEW OF SUPERFICIAL AND DEEP MUSCLES

The superficial back muscles move the arms and shoulders. The deep erector spinae muscles act to extend (straighten) the back by pulling the trunk upward to an erect position, and to control back flexion (bending forward at the waist).

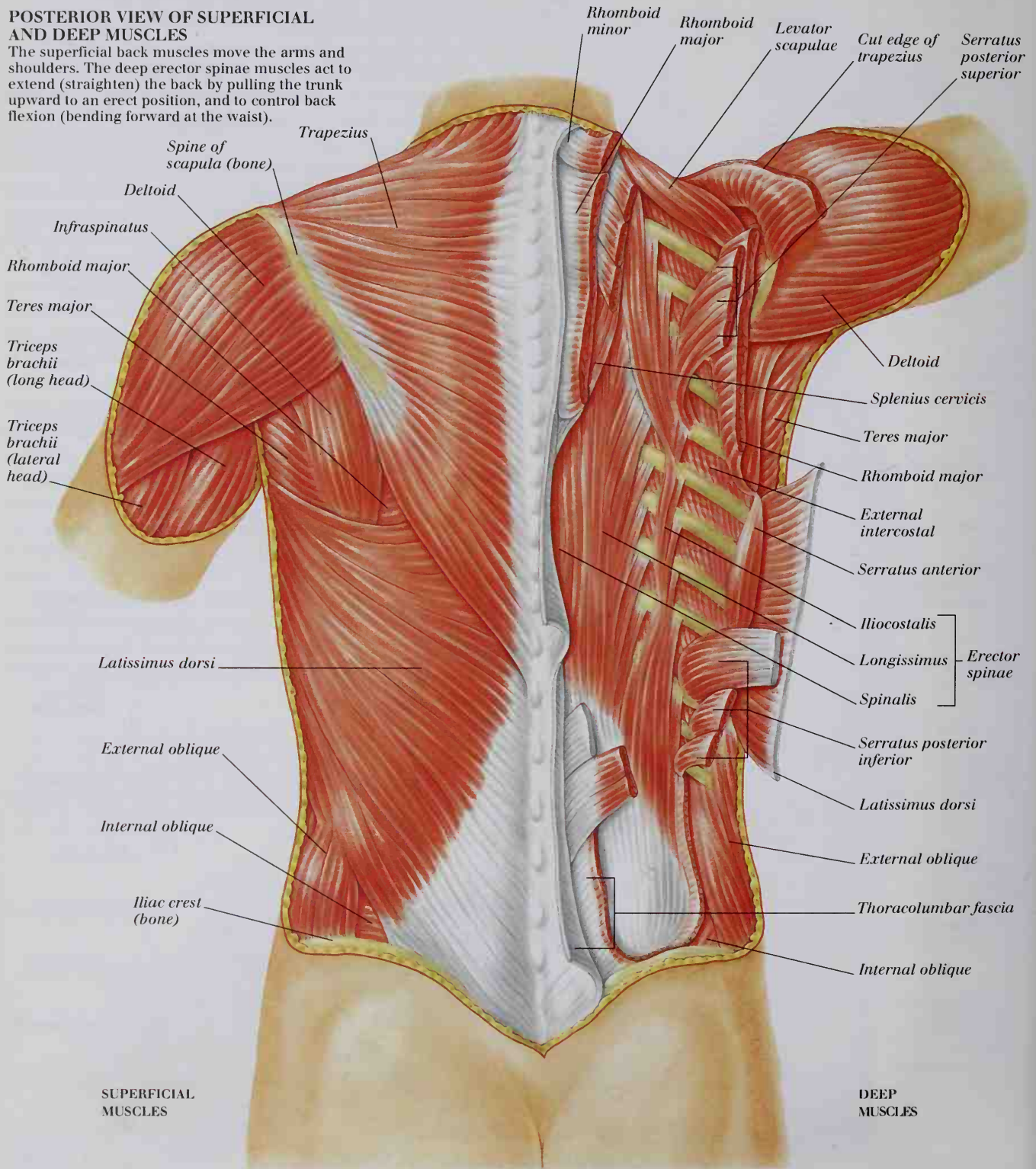

SUPERFICIAL MUSCLES

DEEP MUSCLES

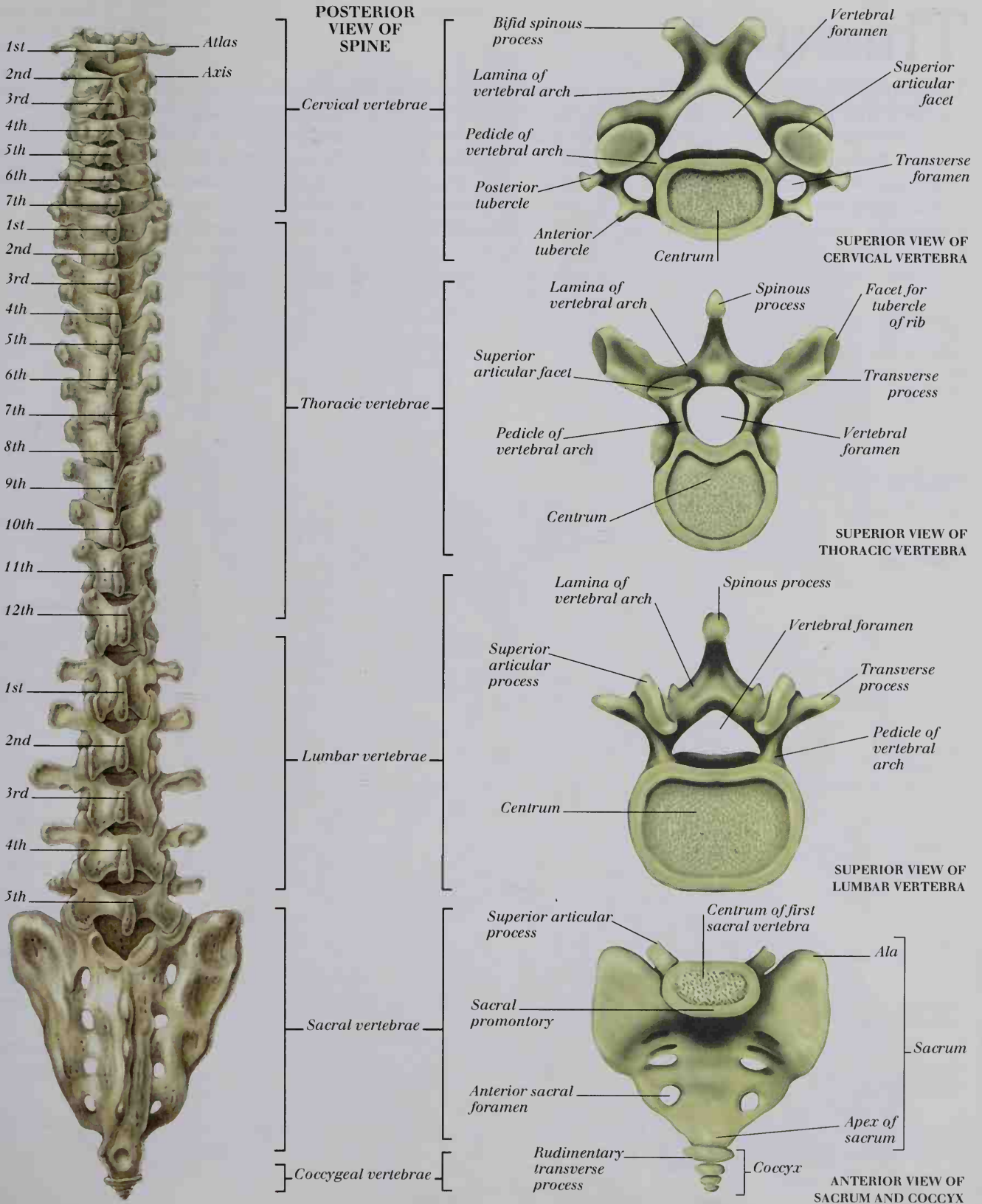

Thorax 1

THE THORAX, OR CHEST, IS THE UPPER PART OF THE TRUNK, and lies below the neck and above the abdomen. The wall of the thorax – formed by the chest muscles, ribs, and intercostal muscles – surrounds the thoracic cavity. This is separated from the abdominal cavity by the diaphragm. The thoracic cavity contains the heart and major blood vessels; right and left lungs; the trachea and bronchi; and the esophagus, which connects the throat and stomach. Two thin membranes called pleurae surround the lungs, sliding over each other to prevent friction with the thoracic wall during breathing. The heart is enclosed by membranes that form a sac called the pericardium, which protects the heart and reduces friction as it beats. Blood vessels entering the heart are the inferior and superior venae cavae and the pulmonary veins. Leaving the heart, blood is carried through the aorta and the pulmonary trunk.

THE THORACIC CAVITY

The open thorax reveals the rib cage and diaphragm, which form the boundaries of the thoracic cavity, and the heart, lungs, and major blood vessels, which occupy most of the space within the cavity.

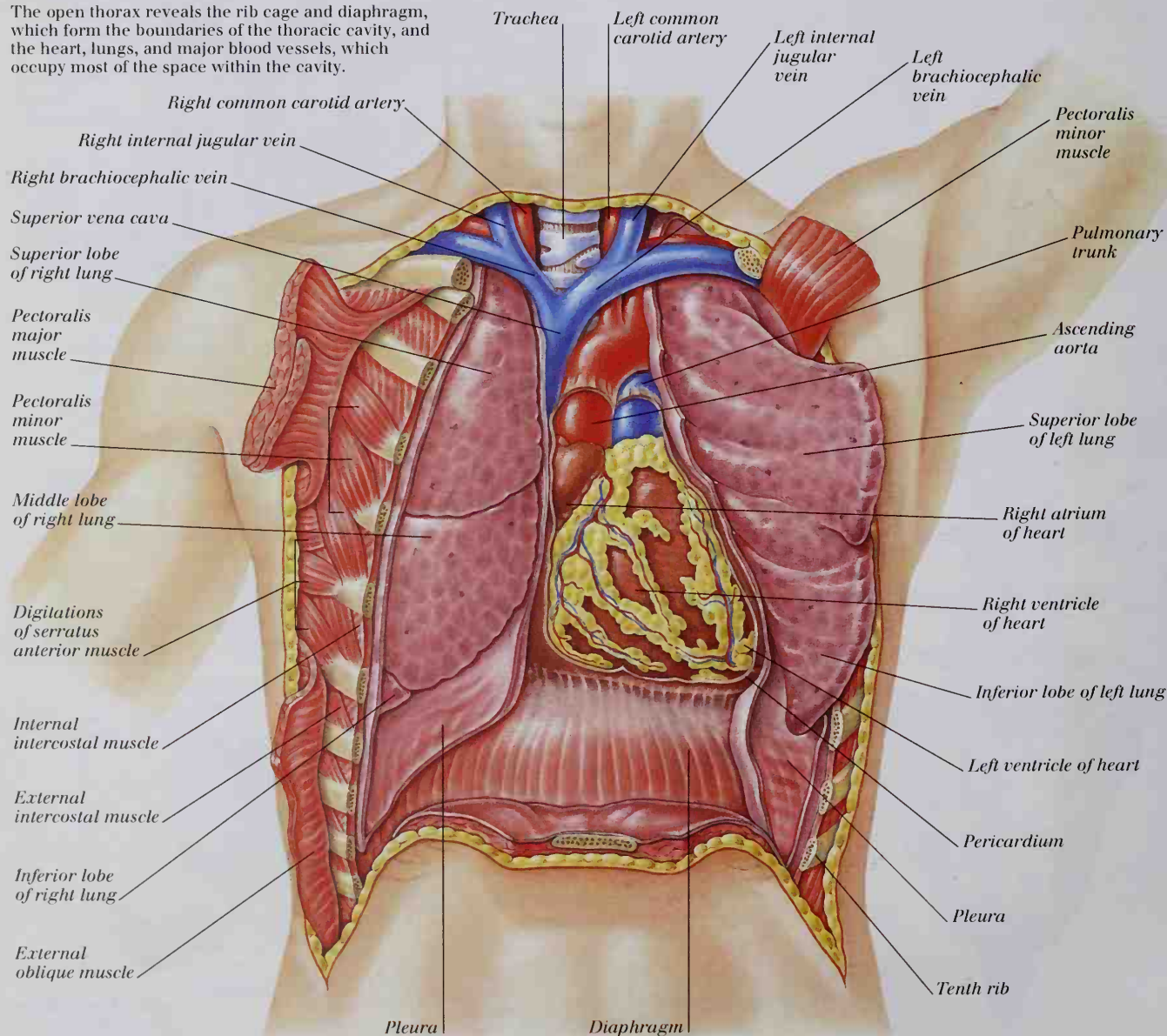

THE LUNGS

Each lung consists of an air-conducting network of tubular passages, known as the bronchial tree. This consists of the principal (primary) bronchi - two branches of the trachea - which divide into lobar (secondary) bronchi. These, in turn, divide into segmental (tertiary) bronchi, which divide repeatedly to form tiny tubes called bronchioles.

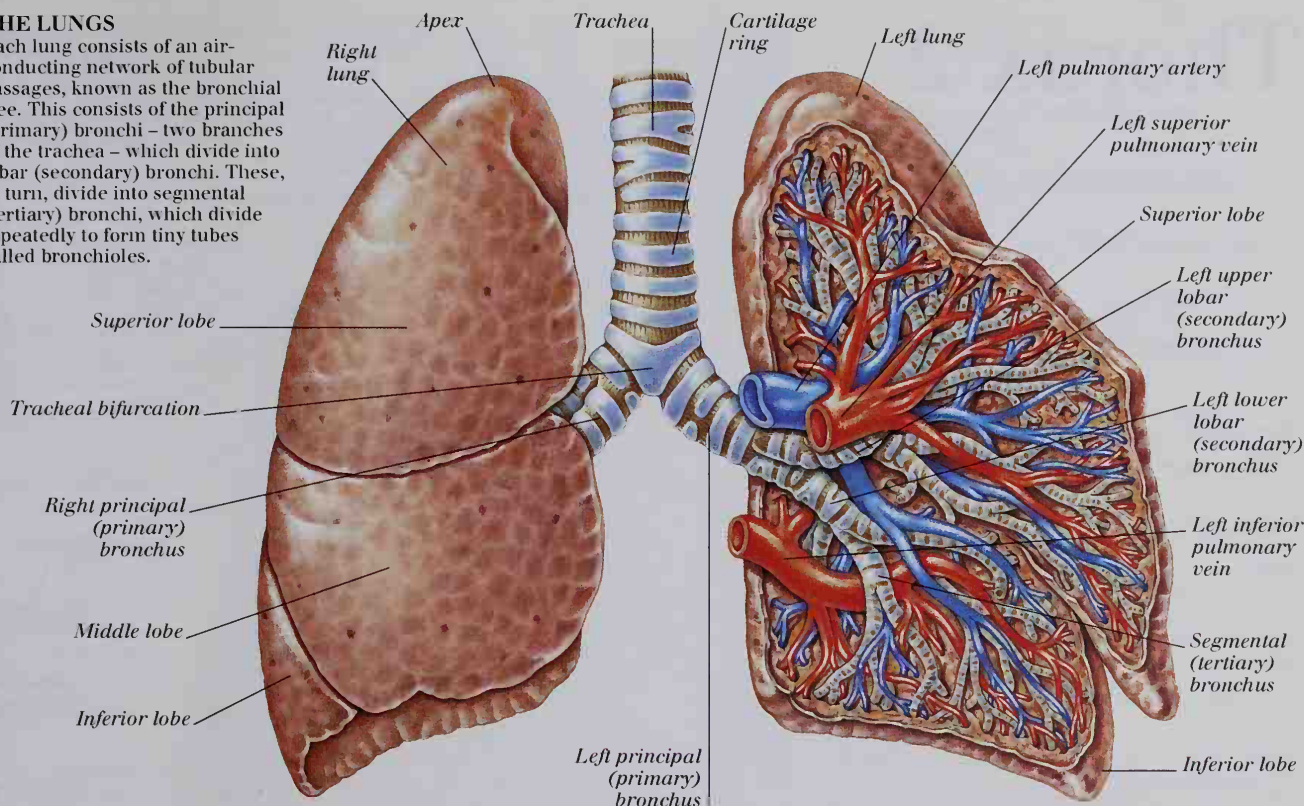

POSTERIOR VIEW OF THE HEART

The heart's muscular walls have their own blood supply. Oxygen-rich blood is carried to the walls of the atria and ventricles by the coronary arteries; oxygen-poor blood is removed by the cardiac veins that join to form the coronary sinus.

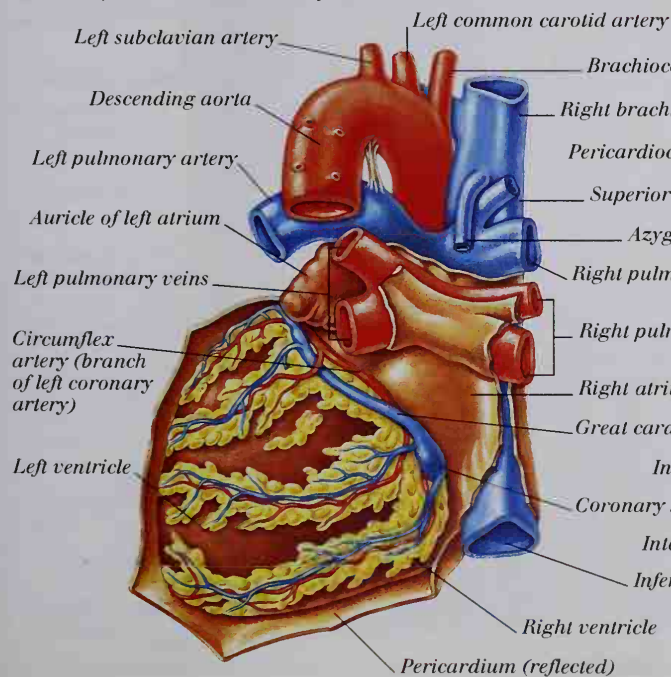

RIGHT LATERAL VIEW OF THE HEART

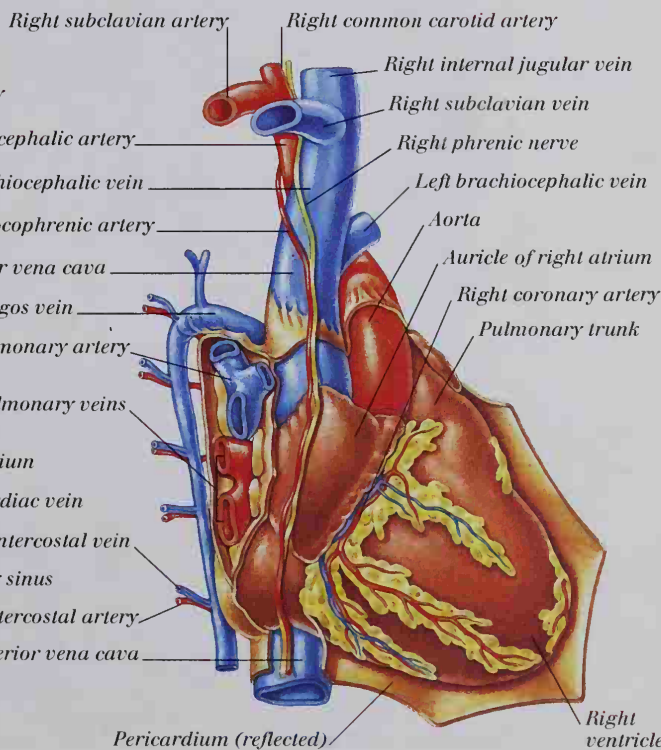

Thorax 2

LUNGS PULLED BACK TO SHOW HEART

The fist-sized heart is contained within a cavity in the middle of the thorax. It is enclosed by the double-walled pericardium, which prevents friction, and is normally overlapped and partially covered by the lungs.

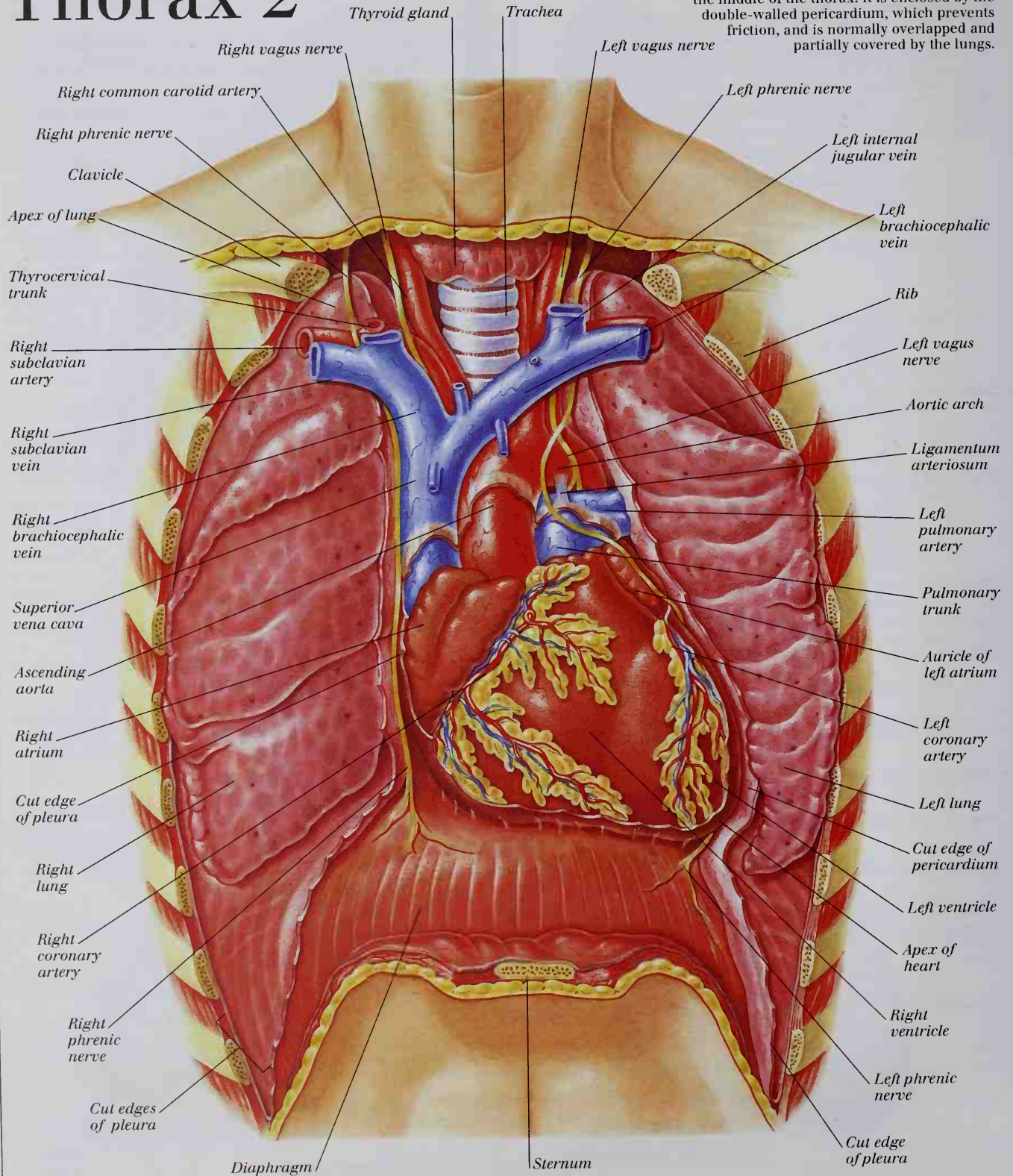

ANTERIOR VIEW OF THORACIC CAVITY

The back wall of the thoracic cavity is formed by the ribs, intercostal muscles, and spine (vertebral column).

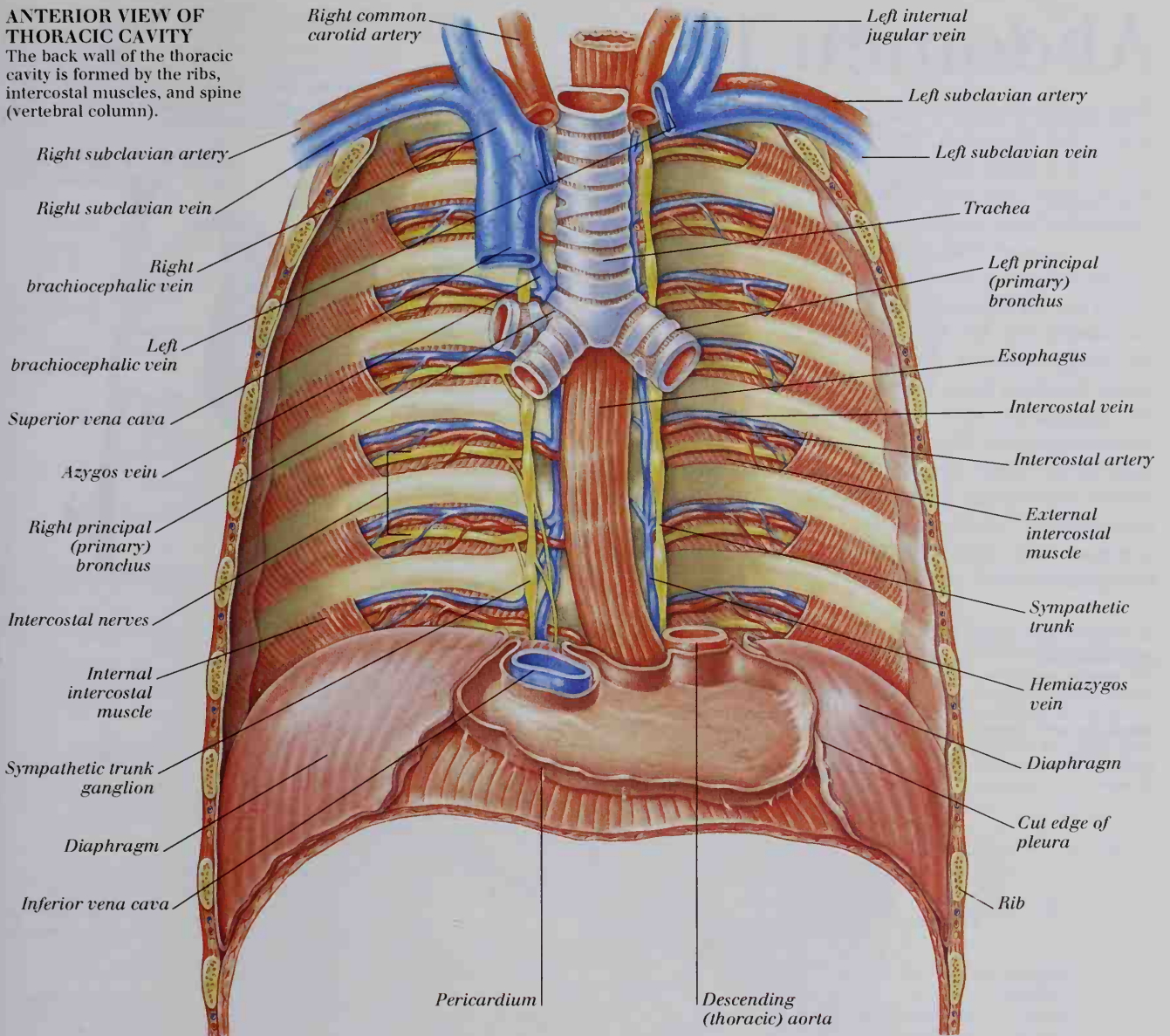

SUPERIOR VIEW OF LARYNX

The vocal cords are horizontal membranes stretching between the pieces of cartilage that make up the larynx (voice box). They vibrate in the airstream to produce sounds.

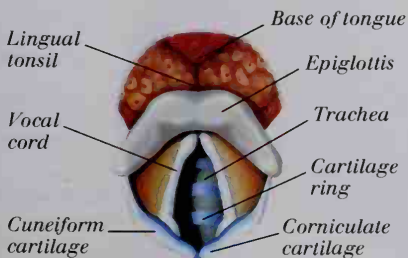

CROSS SECTION OF TRACHEA

C-shaped cartilage rings prevent the trachea from collapsing, unlike the esophagus, which remains flattened unless food passes along it.

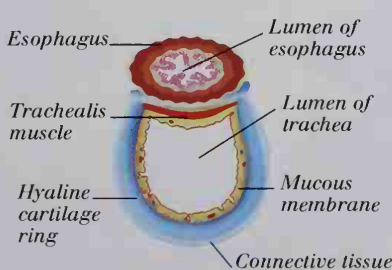

EXPLODED VIEW OF RIB CAGE

The rib cage consists of twelve pairs of curved ribs, the vertebral column, and the sternum, to which most are attached anteriorly through the costal cartilages.

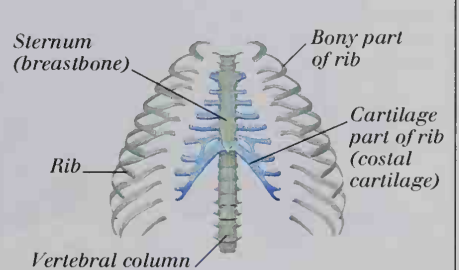

Abdomen 1

THE ABDOMEN LIES IN THE LOWER part of the trunk between the thorax and the pelvis. The wall of the abdomen surrounds the abdominal cavity (which is separated from the thoracic cavity by the diaphragm), and protects the organs contained within it. Four pairs of muscles form the abdominal wall: the external oblique, internal oblique, transversus abdominis, and rectus abdominis. Within the abdominal cavity are the stomach, and the small and large intestines, which are all digestive organs; the liver and pancreas, which are associated with the digestive system; the spleen, which forms part of the body's defenses against disease; and two kidneys, which remove waste products from the blood. A thin, continuous membrane called the peritoneum covers the abdominal organs and lines the abdominal cavity to prevent organs from sticking to each other and causing severe pain. In the lower abdomen, the dorsal aorta (the large artery that carries blood away from the heart) divides into right and left common iliac arteries, which supply the pelvic region and legs. The right and left common iliac veins join to form the inferior vena cava, a large vein that carries blood back to the heart.

THE GALLBLADDER

This muscular sac stores a greenish liquid called bile, produced by the liver. During digestion, the gallbladder contracts, squirting bile along ducts into the duodenum, where it aids the breakdown of fats.

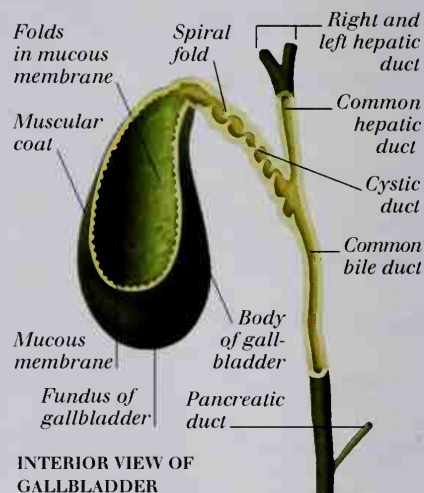

INTERIOR VIEW OF GALLBLADDER

SUPERFICIAL VIEW OF ABDOMINAL CAVITY

The greater omentum covers the intestines like a fatty apron. It serves to attach digestive organs to each other and to the body wall, and to protect and insulate the intestines.

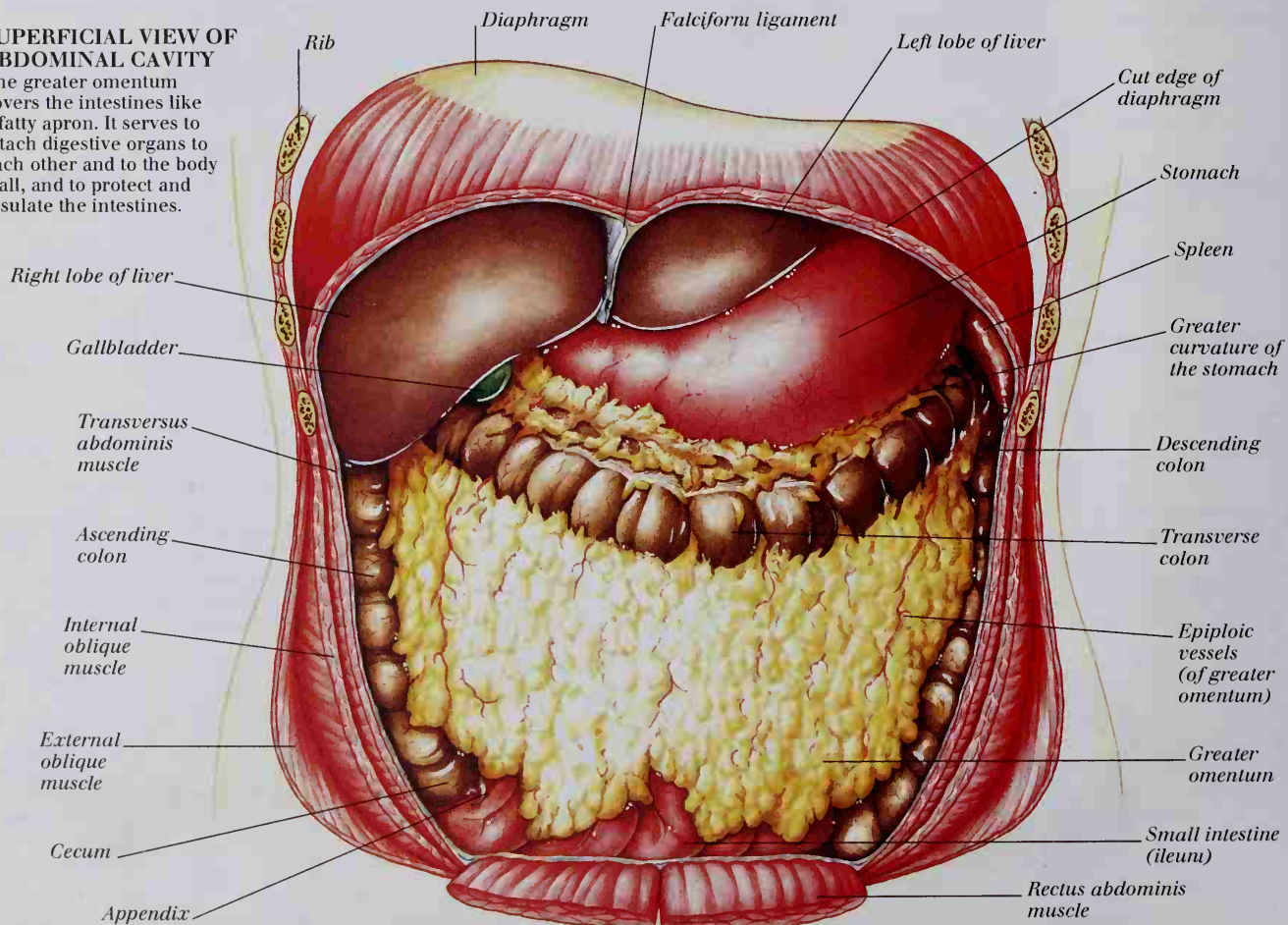

THE ABDOMINAL CAVITY

The intestines form the longest part of the digestive system. In the small intestine, food is digested and absorbed into the bloodstream. The large intestine carries undigested material to the outside of the body, and absorbs water from this waste back into the body.

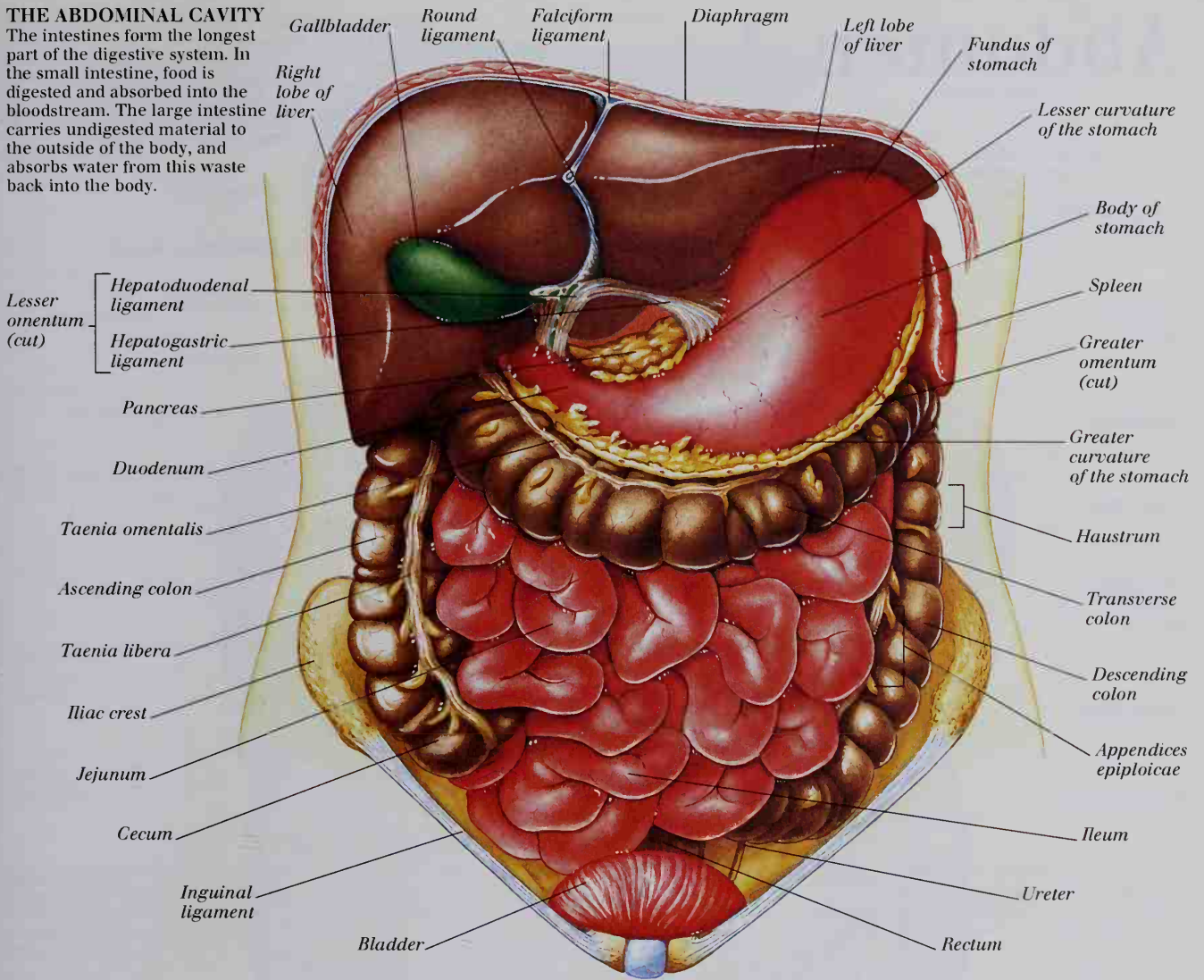

THE LIVER

The liver is the body's largest gland. It performs over 500 functions, which include processing the blood that arrives through the hepatic portal vein, its direct link with the digestive system (see pp. 196-197), and the hepatic artery. It controls levels of fats, amino acids, and

glucose in the blood; stores vitamins A and D; removes worn-out red blood cells; removes drugs and poisons; warms the blood; and produces bile, which is used in digestion. Blood leaves the liver through the hepatic veins, which empty into the inferior vena cava.

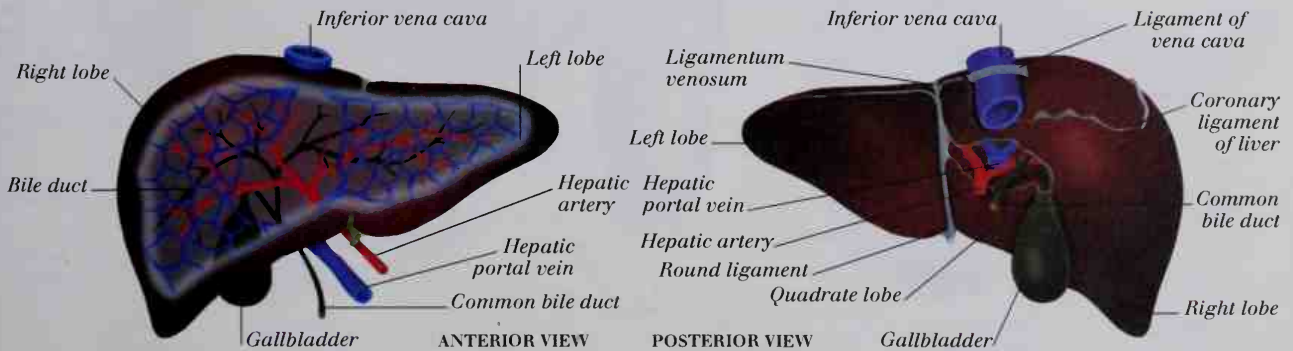

Abdomen 2

THE ABDOMINAL CAVITY WITH LIVER REMOVED

The removal of the liver reveals the opening in the diaphragm through which the esophagus enters the abdomen from the thorax. This carries food into the stomach and then the duodenum, which is the first, short section of the small intestine.

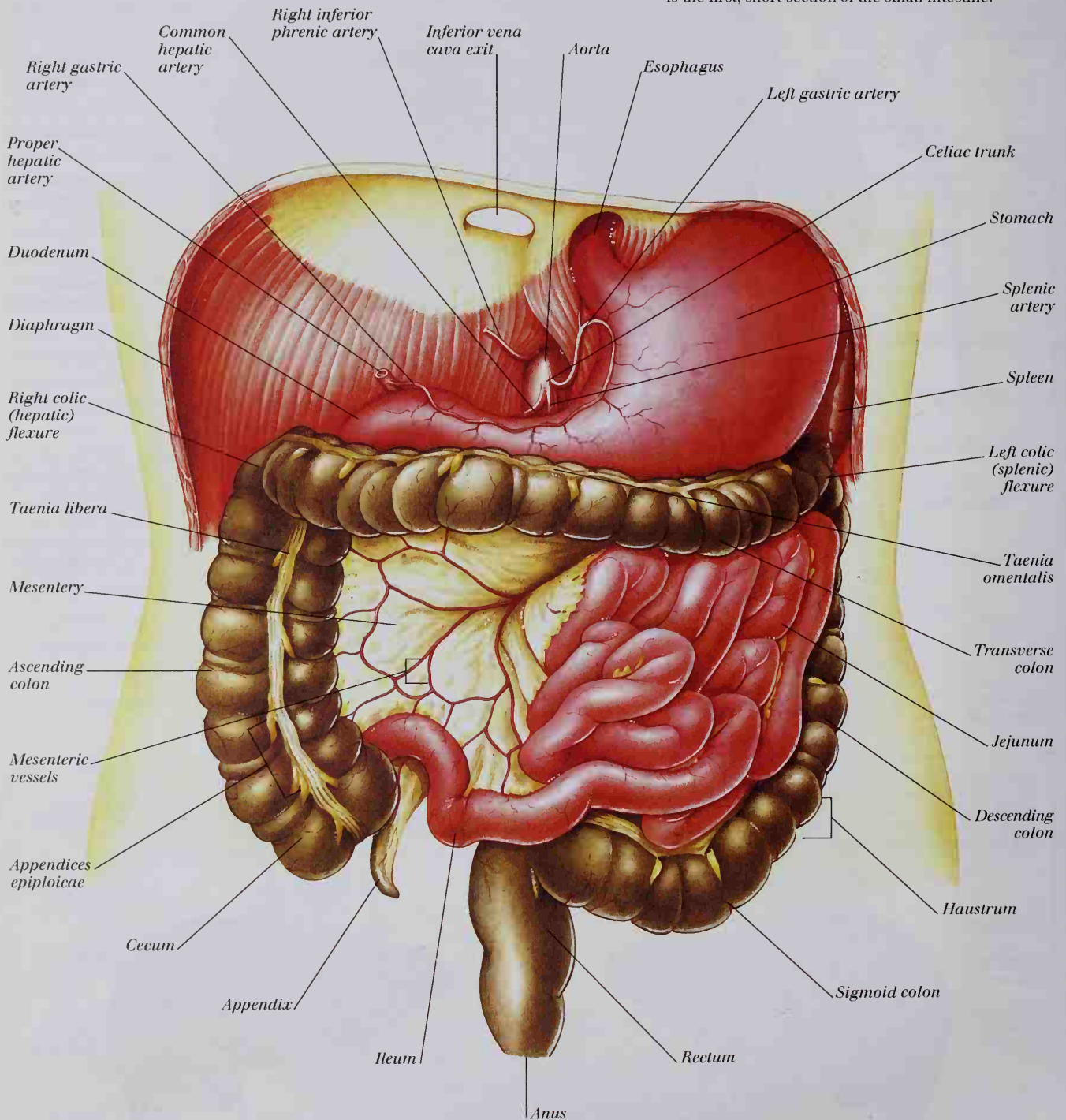

THE HEPATIC PORTAL SYSTEM

The hepatic portal system of veins carries blood, rich in food, from the digestive organs to the liver. There, liver cells break down some foods and store others. This process restores the normal chemical composition of blood.

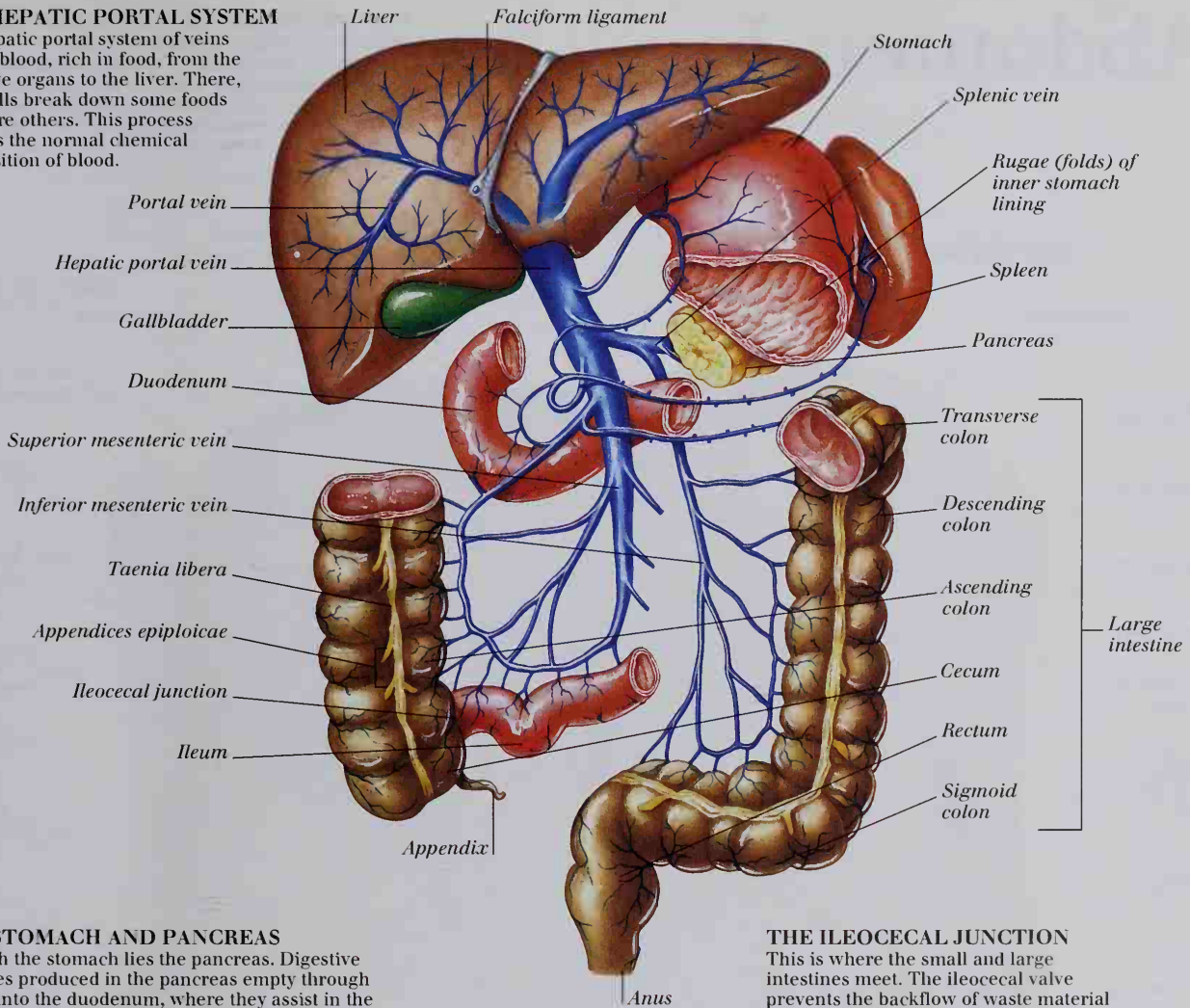

THE STOMACH AND PANCREAS

Beneath the stomach lies the pancreas. Digestive enzymes produced in the pancreas empty through a duct into the duodenum, where they assist in the breakdown of food.

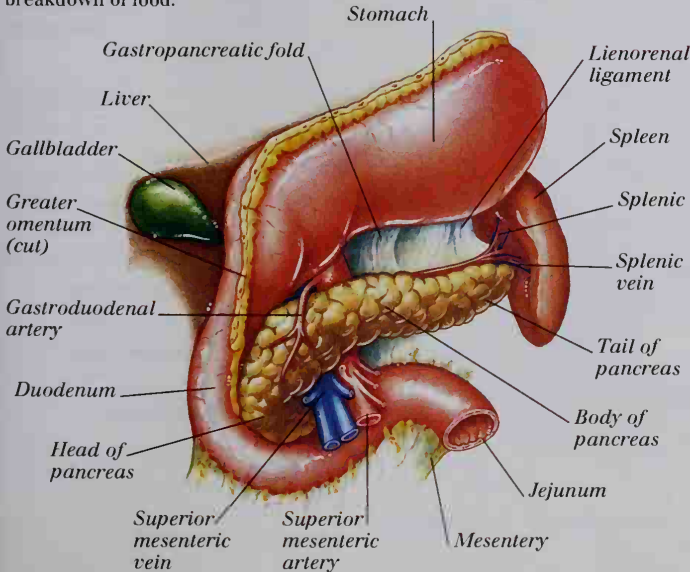

THE ILEOCECAL JUNCTION

This is where the small and large intestines meet. The ileocecal valve prevents the backflow of waste material from the colon into the ileum.

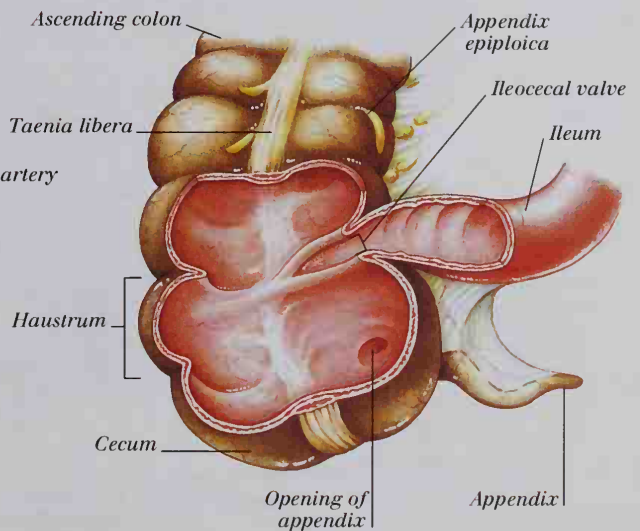

Abdomen 3

THE ABDOMINAL CAVITY WITH DIGESTIVE ORGANS REMOVED

The removal of the digestive organs reveals the two kidneys. These remove waste products and excess water from blood, which enters the kidneys through the renal arteries; the waste is then passed to the bladder, where it is stored before release from the body.

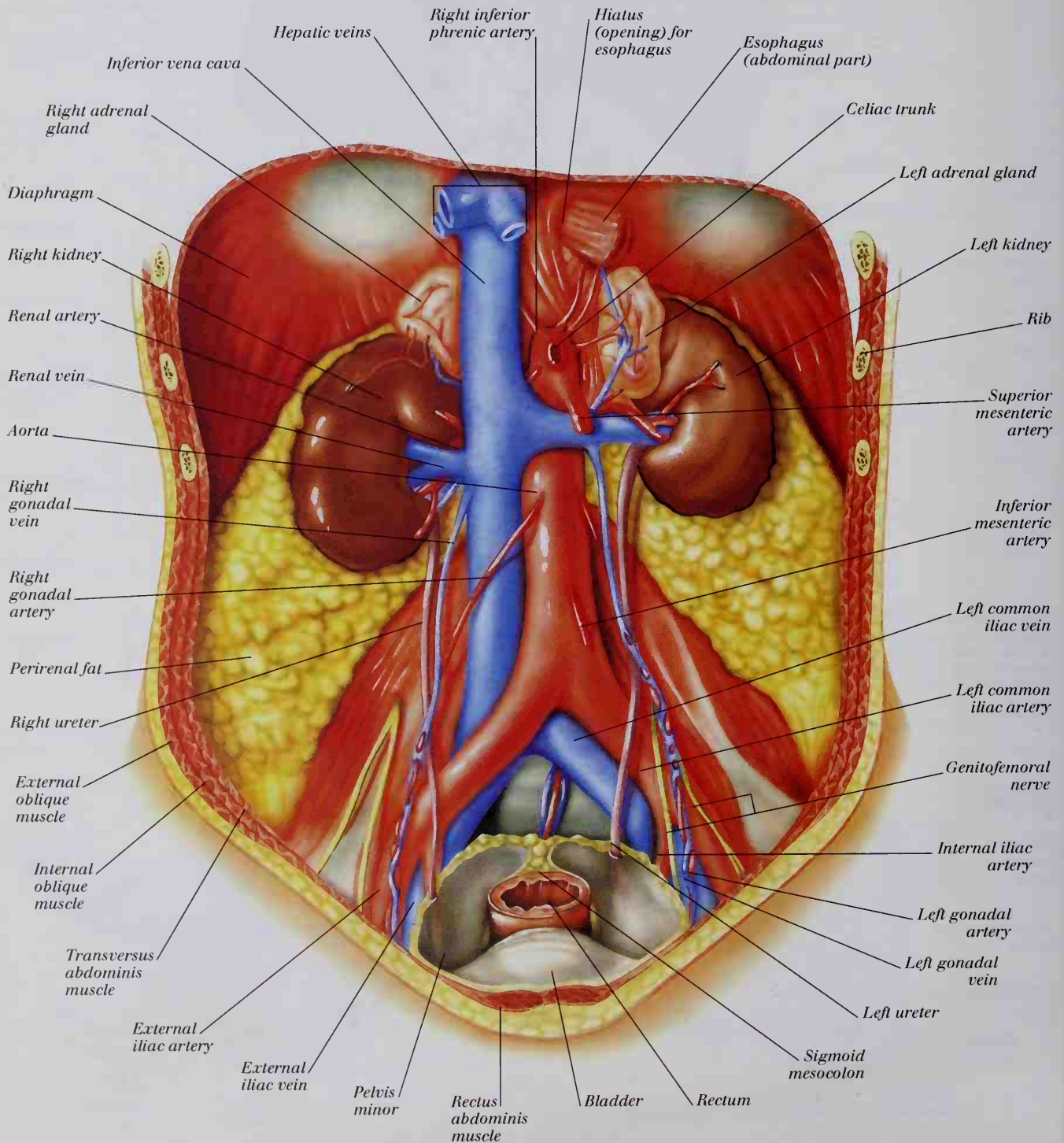

THE POSTERIOR ABDOMINAL WALL

Major muscles of the posterior abdominal wall include the quadratus lumborum, which helps support the backbone; the iliacus and psoas major, which flex the hip and help maintain posture; and the transversus abdominis, which compresses abdominal contents.

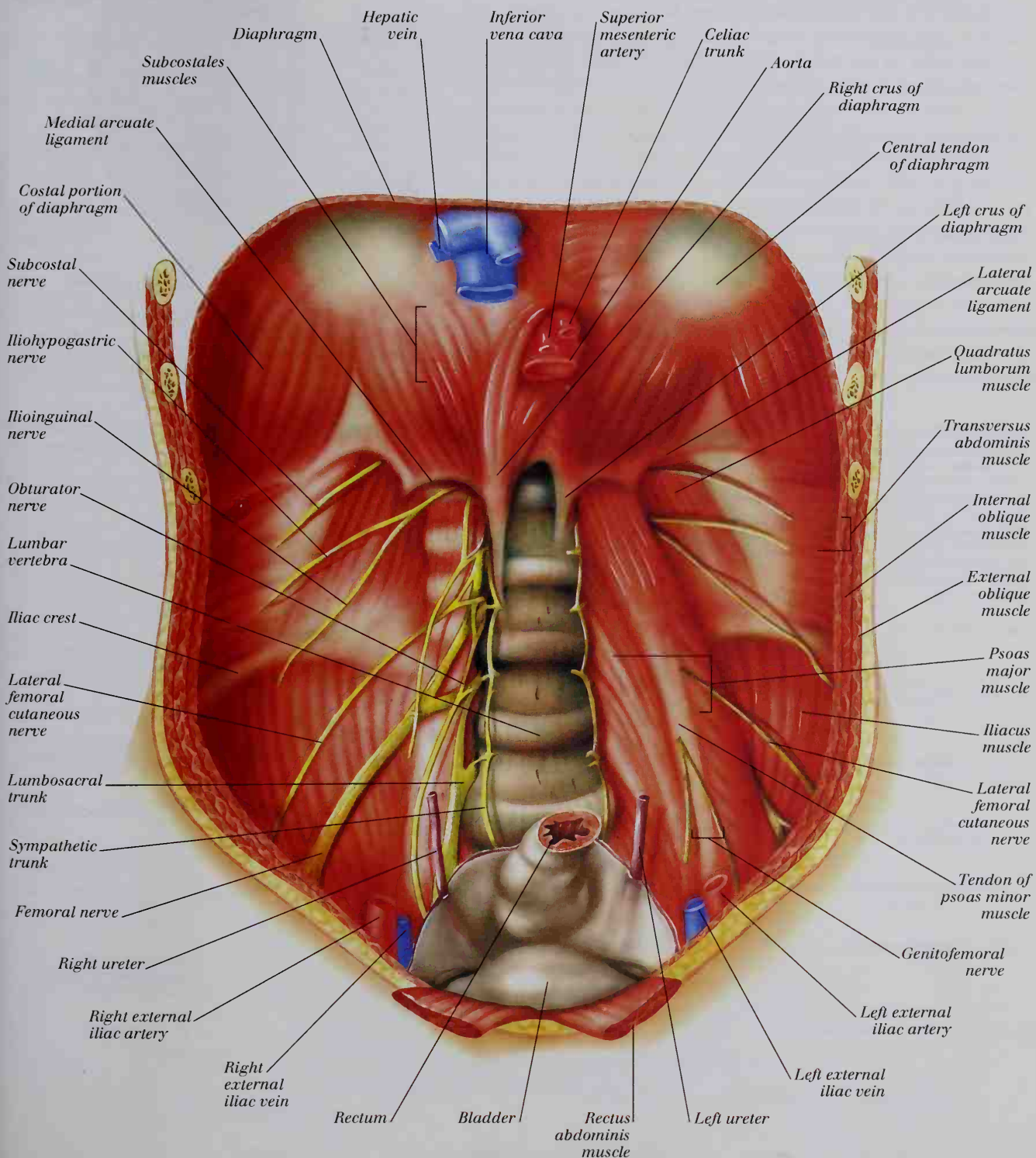

Pelvic region 1

THE PELVIC AREA IS THE LOWEST part of the trunk. It lies below the abdomen and above the junction between the trunk and the legs. The framework of the pelvic region is formed **anteriorly** and **laterally** by the pelvic (hip) girdle, and **posteriorly** by the sacrum, which is part of the vertebral column. Together, these bones form the bowl-shaped pelvis, which provides attachment sites for the muscles of the legs and trunk, and surrounds and protects the organs within the pelvic cavity. The pelvic cavity is continuous with, and lies below the abdominal cavity. It contains the rectum, the terminal region of the large intestine, which opens out of the body through the anus; the bladder, which is a muscular bag that stores urine; and the internal reproductive organs of the male and female. The muscles of the pelvic floor, or pelvic diaphragm – which include the levator ani – close the lower opening of the pelvis (the pelvic outlet) and support the pelvic organs, preventing them from being forced downward by the weight of the content of the abdomen.

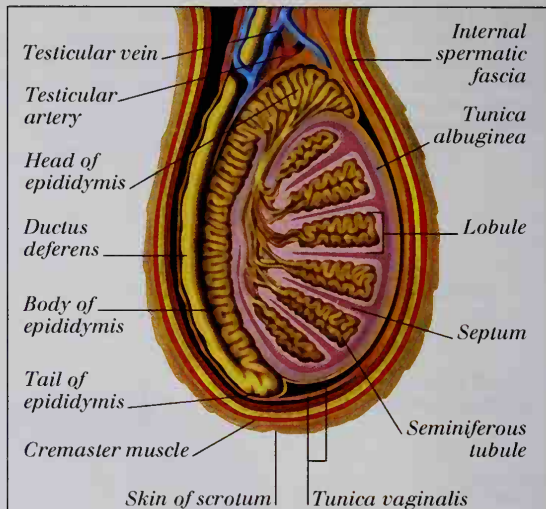

ANATOMY OF THE TESTIS

The testis consists of tightly coiled, sperm-producing seminiferous tubules connected through efferent ducts to the crescent-shaped epididymis. Sperm mature here before entering the ductus deferens, which carries them toward the penis.

MALE PERINEUM

The perineum overlies the pelvic floor. Its muscles include the anal sphincter, which controls the release of feces; the urinogenital diaphragm, which controls the release of urine; the bulbospongiosus, which empties the urethra of urine; and the ischiocavernosus, which helps maintain penile erection.

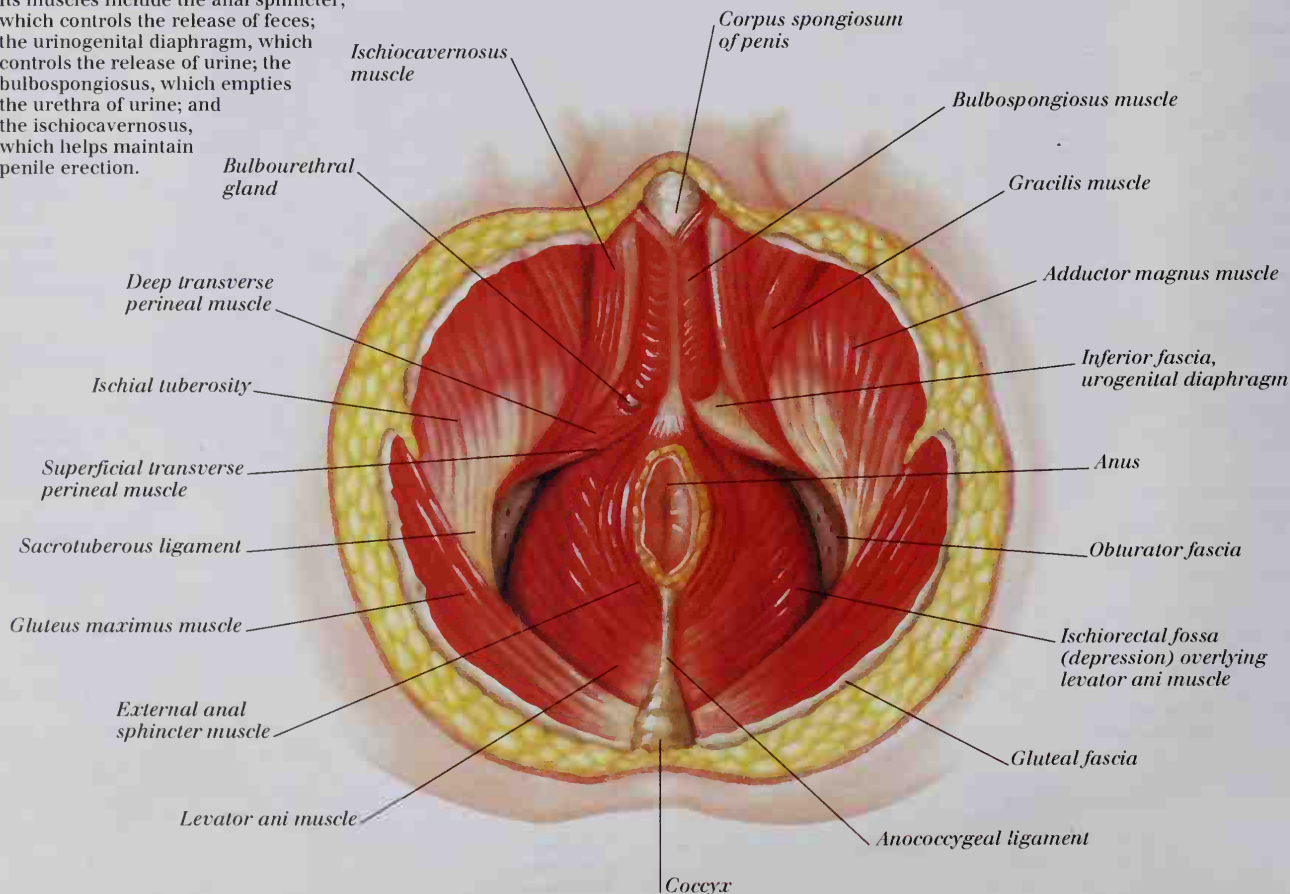

MALE PELVIC CAVITY

Most of the male reproductive system lies outside the pelvic cavity. From each of the testes runs a ductus deferens that joins the urethra in the prostate gland. The urethra opens through the erectile penis.

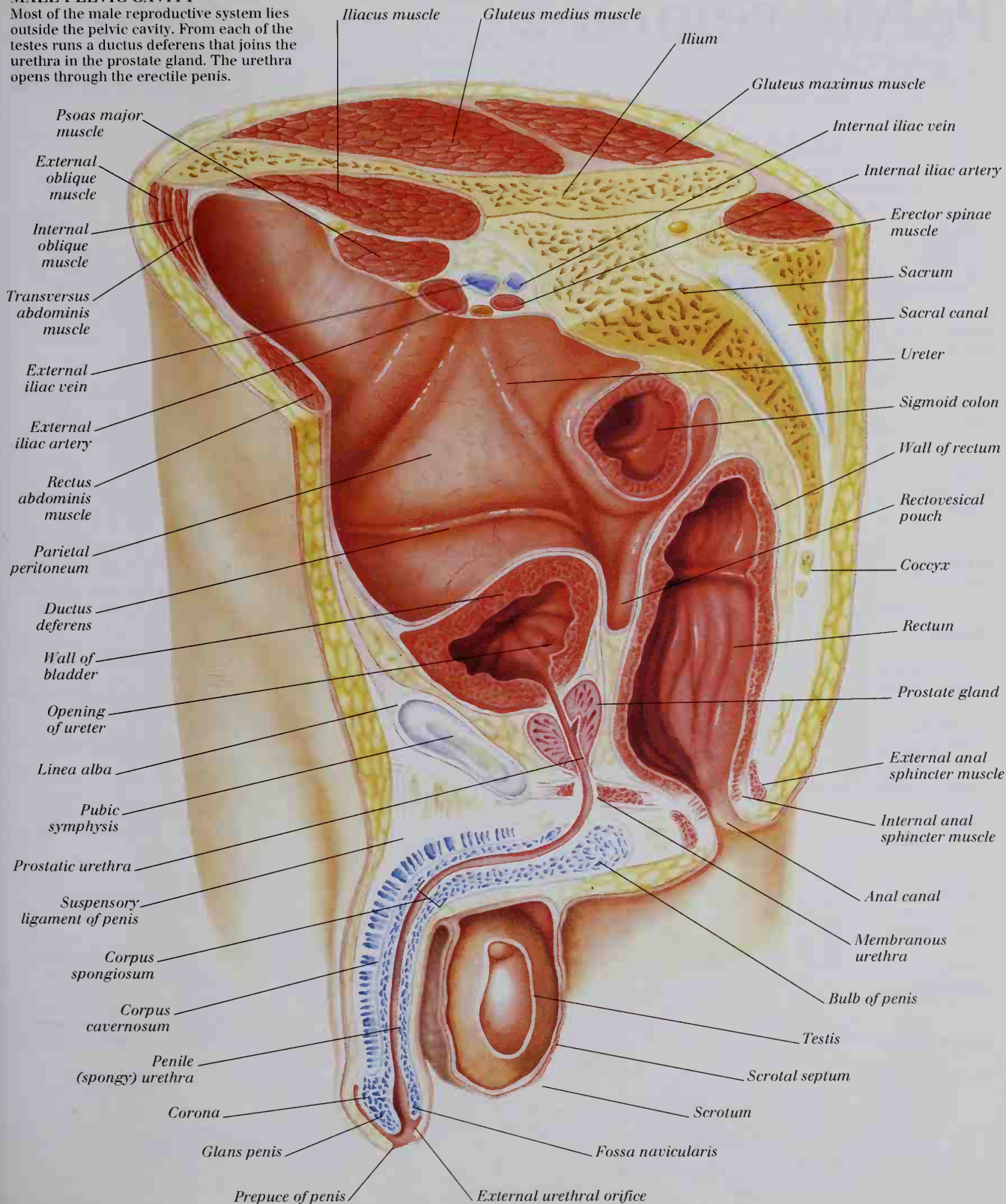

Pelvic region 2

FEMALE PELVIC CAVITY
 Extending from each side of the uterus is a fallopian tube, with ends that extend into fingerlike fimbriae overhanging the ovary. The uterus is connected to the vulva (external genitalia) through the vagina.

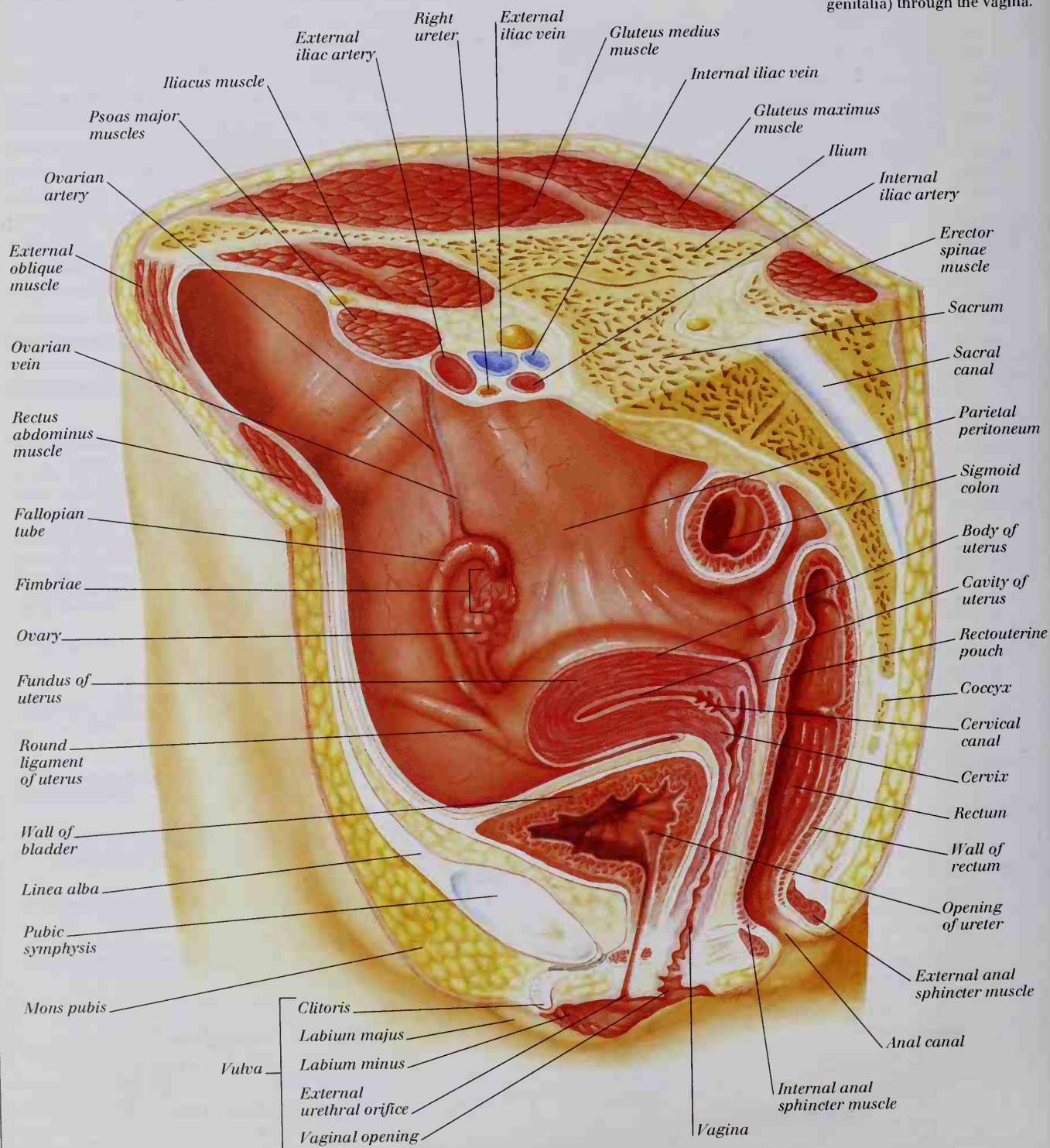

THE MENSTRUAL CYCLE

Throughout every month, women of reproductive age experience the menstrual cycle – a sequence of events that prepares their bodies for pregnancy. It has three phases. During the menstrual phase (also known as the “period”), the lining of the

uterus breaks down and is shed with some blood through the vagina. The proliferative phase, when the uterine lining thickens once more, coincides with the ripening of a new egg (ovum) inside the ovary. After the egg is released at ovulation, around day 14, the

uterine lining thickens still further during the secretory phase, in readiness to receive the egg, should it be fertilized by a sperm. If the egg is not fertilized, there is no pregnancy, so the uterine lining breaks down and is shed, and the cycle begins again.

MENSTRUAL (DAYS 1-5)

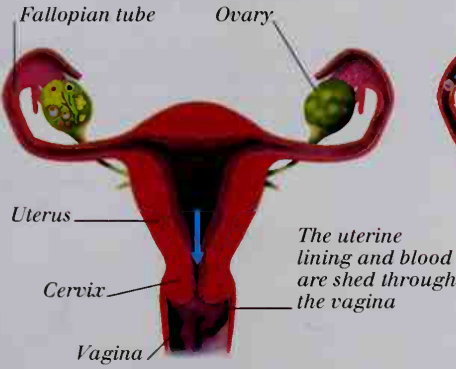

PROLIFERATIVE (DAYS 6-14)

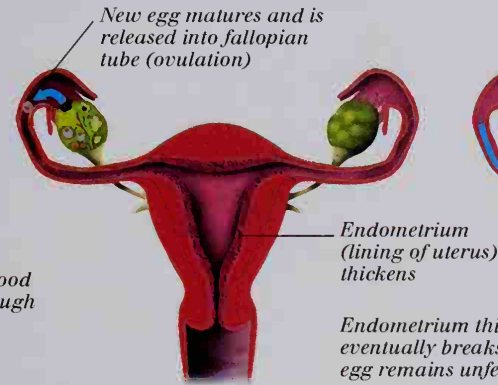

SECRETORY (DAYS 15-28)

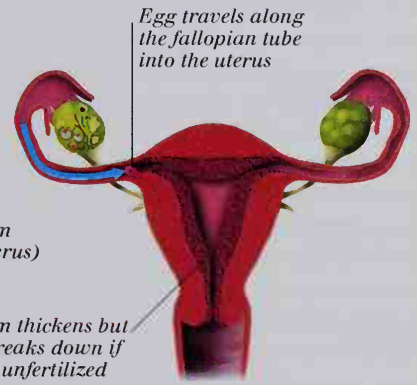

FEMALE PERINEUM

The urinogenital diaphragm and the anal sphincter control the release of urine and feces respectively. The bulbospongiosus constricts the vaginal opening; the ischioavernosus assists in erection of the clitoris.

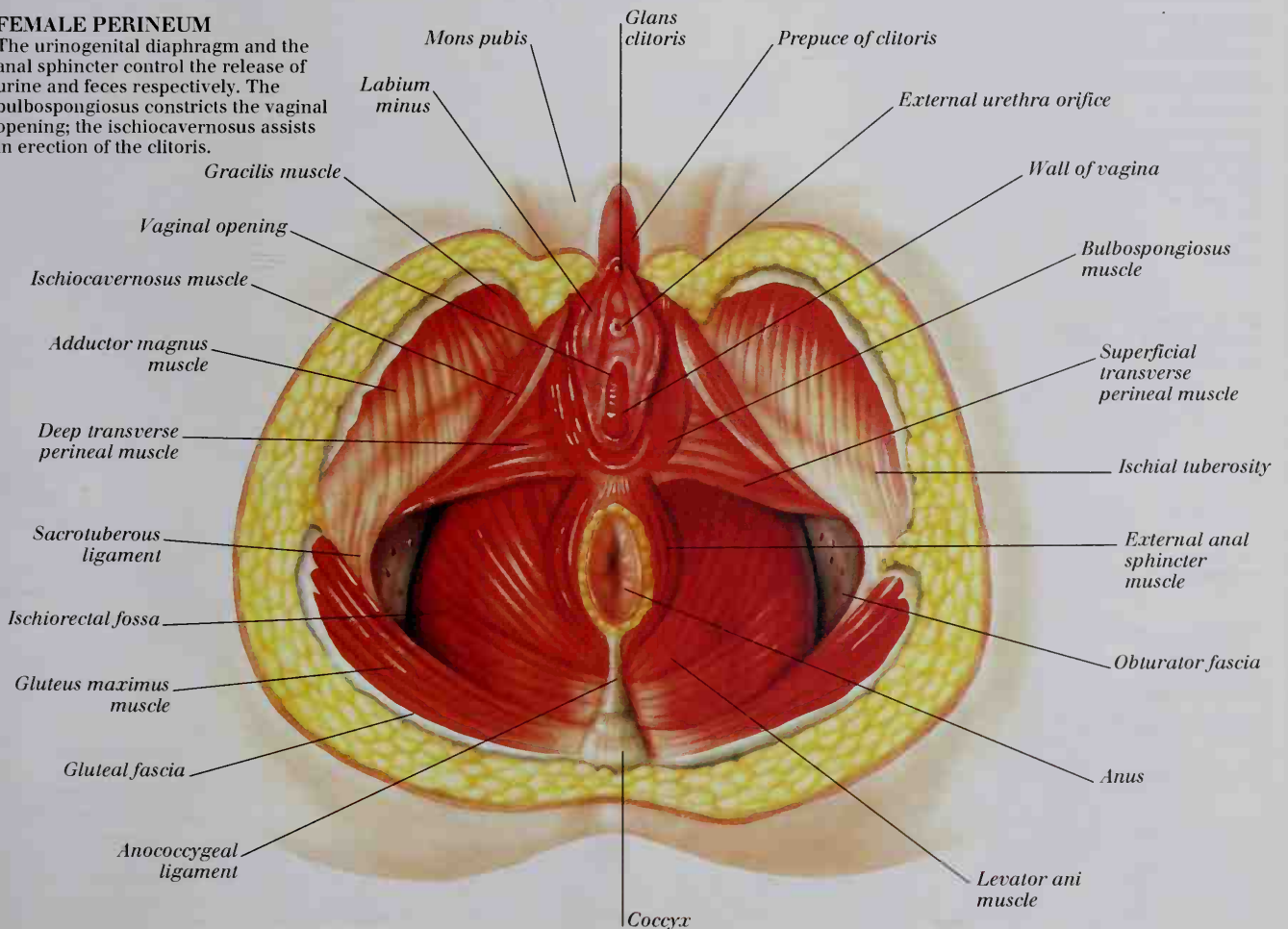

Shoulder and upper arm

THE BONY FRAMEWORK OF THE SHOULDER and upper arm is formed by the scapula (shoulder blade), clavicle (collarbone), and humerus (upper arm bone). At its upper end, the humerus forms a joint with the scapula at the shoulder, which permits movement of the upper arm in all planes. The group of muscles that cross the shoulder joint to move the humerus include the deltoid, pectoralis major, latissimus dorsi, and teres major. The supraspinatus, infraspinatus, teres minor, and subscapularis – collectively, the rotator cuff muscles – stabilize the shoulder joint, preventing its dislocation. At its lower end, the humerus forms a joint with the radius and ulna (forearm bones) at the elbow, which permits flexion (bending) and extension (straightening) only. The muscles that flex the elbow include the biceps brachii, brachioradialis, and brachialis; the muscle that extends the elbow is the triceps brachii. Blood is carried into the arm by the axillary artery (which becomes the brachial artery as it enters the upper arm), and out of the arm by the cephalic vein and the brachial and basilic veins (which join to form the axillary vein as they enter the shoulder). The main nerves supplying the upper arm include the radial, median, and ulnar nerves.

ANTERIOR VIEW OF SUPERFICIAL MUSCLES

The major anterior superficial muscles are the deltoid and pectoralis major, which pull the arm forward or backward, and the biceps (“two heads”) brachii, which flexes the arm at the elbow.

ANTERIOR VIEW OF DEEP MUSCLES

The removal of superficial muscles reveals the coracobrachialis muscle. This pulls the arm forward and upward, or toward the body.

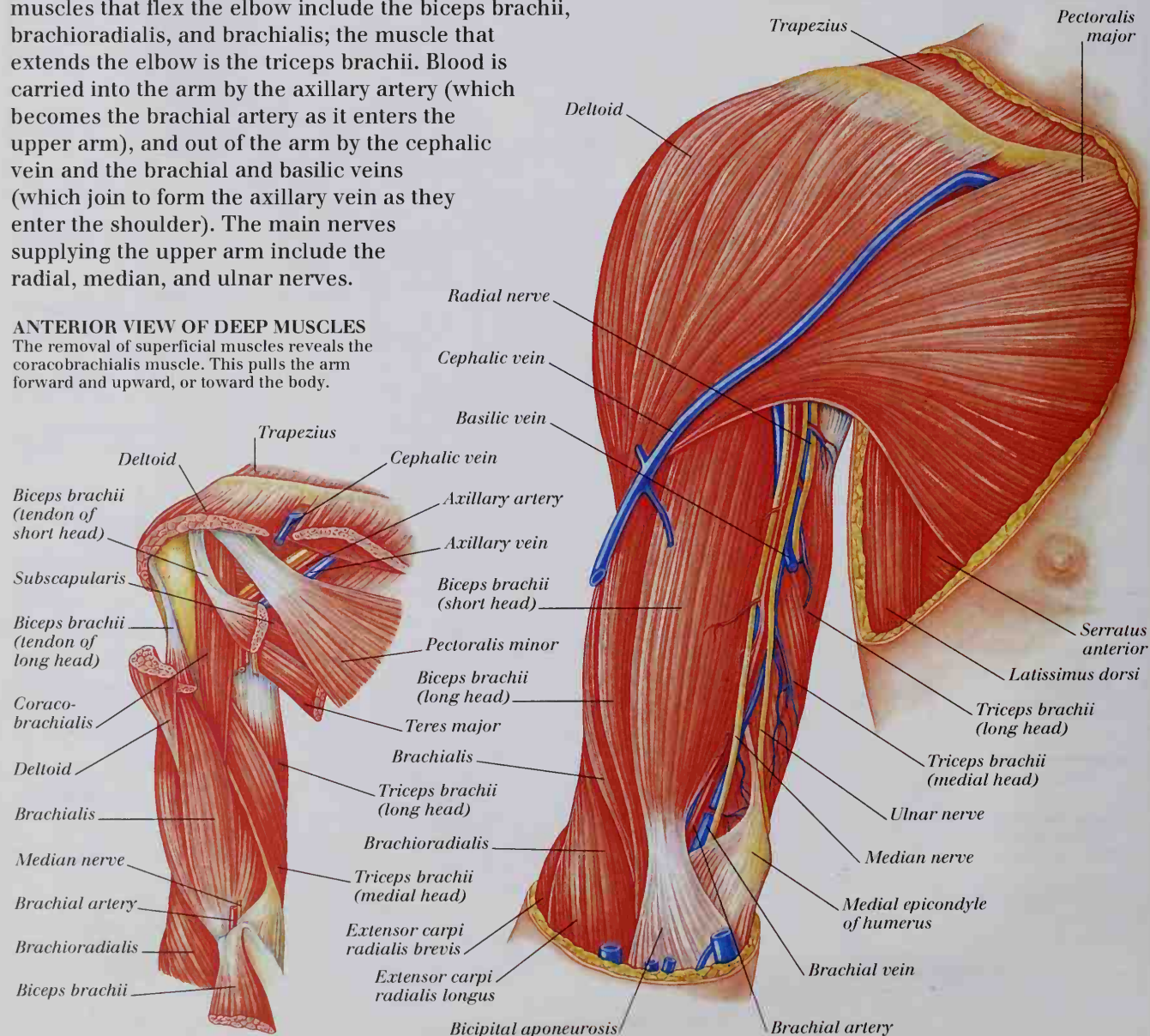

POSTERIOR VIEW OF DEEP MUSCLES

The deep muscles include three of the rotator cuff muscles – the supraspinatus, infraspinatus, and teres minor – which rotate the arm and stabilize the shoulder joint. Also shown is the three-headed origin of the triceps brachii muscle.

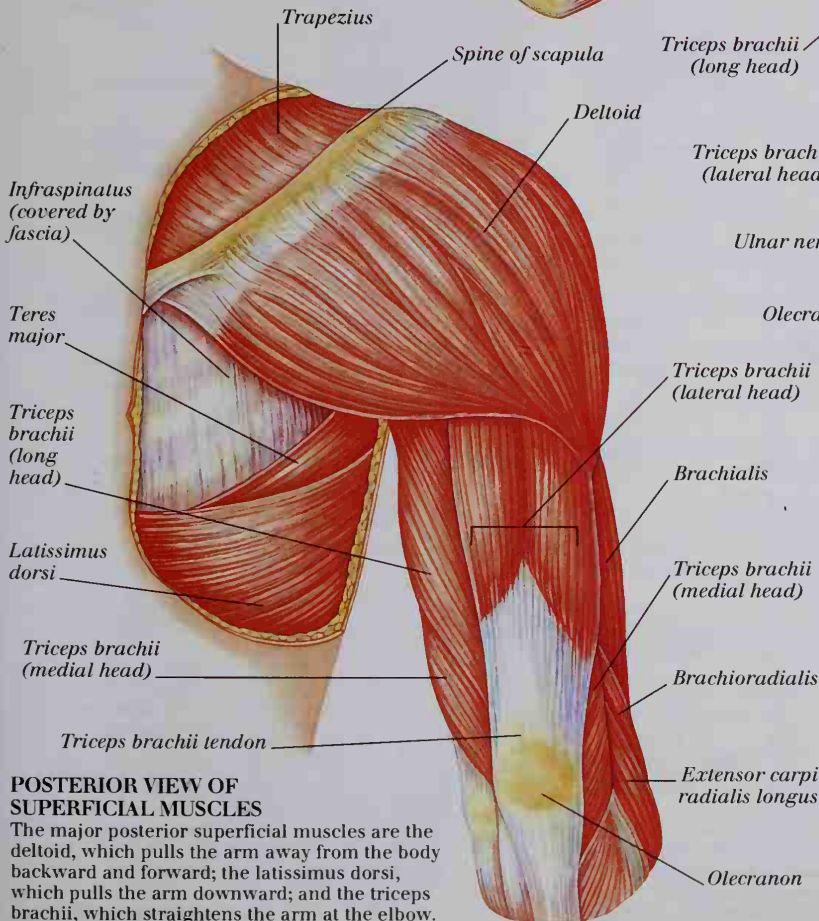
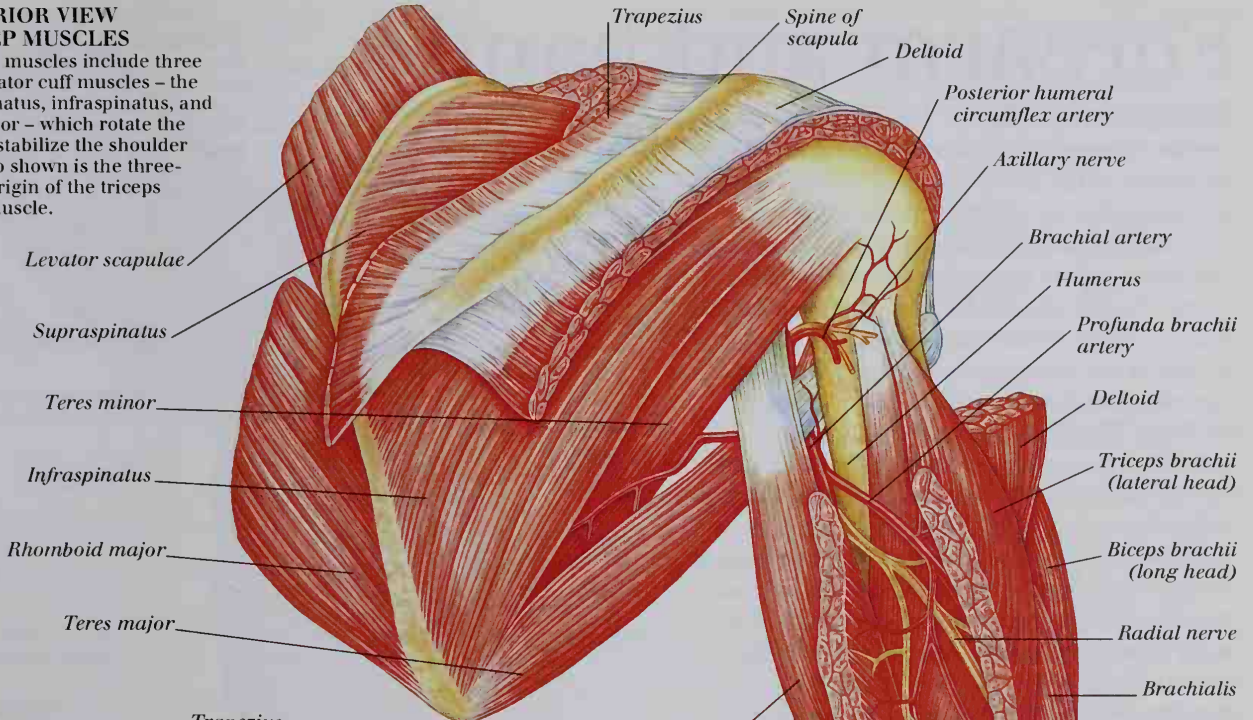

POSTERIOR VIEW OF SUPERFICIAL MUSCLES

The major posterior superficial muscles are the deltoid, which pulls the arm away from the body backward and forward; the latissimus dorsi, which pulls the arm downward; and the triceps brachii, which straightens the arm at the elbow.

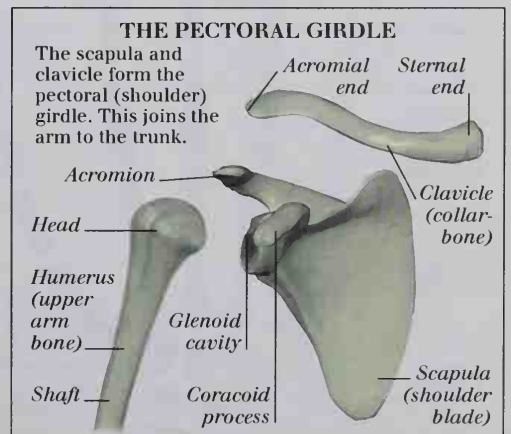

Forearm and hand

THE HAND IS CAPABLE OF A WIDE range of precise movements. It owes its flexibility and versatility to the many muscles of the forearm and hand, and to a bony framework that consists of fourteen phalanges (finger bones), five metacarpals (palm bones), and eight carpals (wrist bones), four of which articulate with the ends of the radius and ulna (forearm bones) at the wrist joint. Forearm muscles taper into long tendons that extend into the hand. These tendons, along with blood vessels and nerves, are held in place by two fibrous bands: the flexor retinaculum and the extensor retinaculum. Most muscles in the anterior (inner) part of the forearm are flexors; most in the posterior (outer) part are extensors. Wrist flexors include the flexor carpi radialis; wrist extensors include the extensor carpi ulnaris. Finger flexors include the flexor digitorum superficialis; finger extensors include the extensor digitorum. Inside the hand, the lumbrical and the interosseus muscles between the metacarpals flex the metacarpophalangeal (knuckle) joints and extend the fingers.

ANTERIOR VIEW OF SUPERFICIAL MUSCLES
The median nerve controls the action of most of the flexor muscles of the forearm, which flex the wrist, and the flexor and abductor pollicis brevis, which move the thumb.

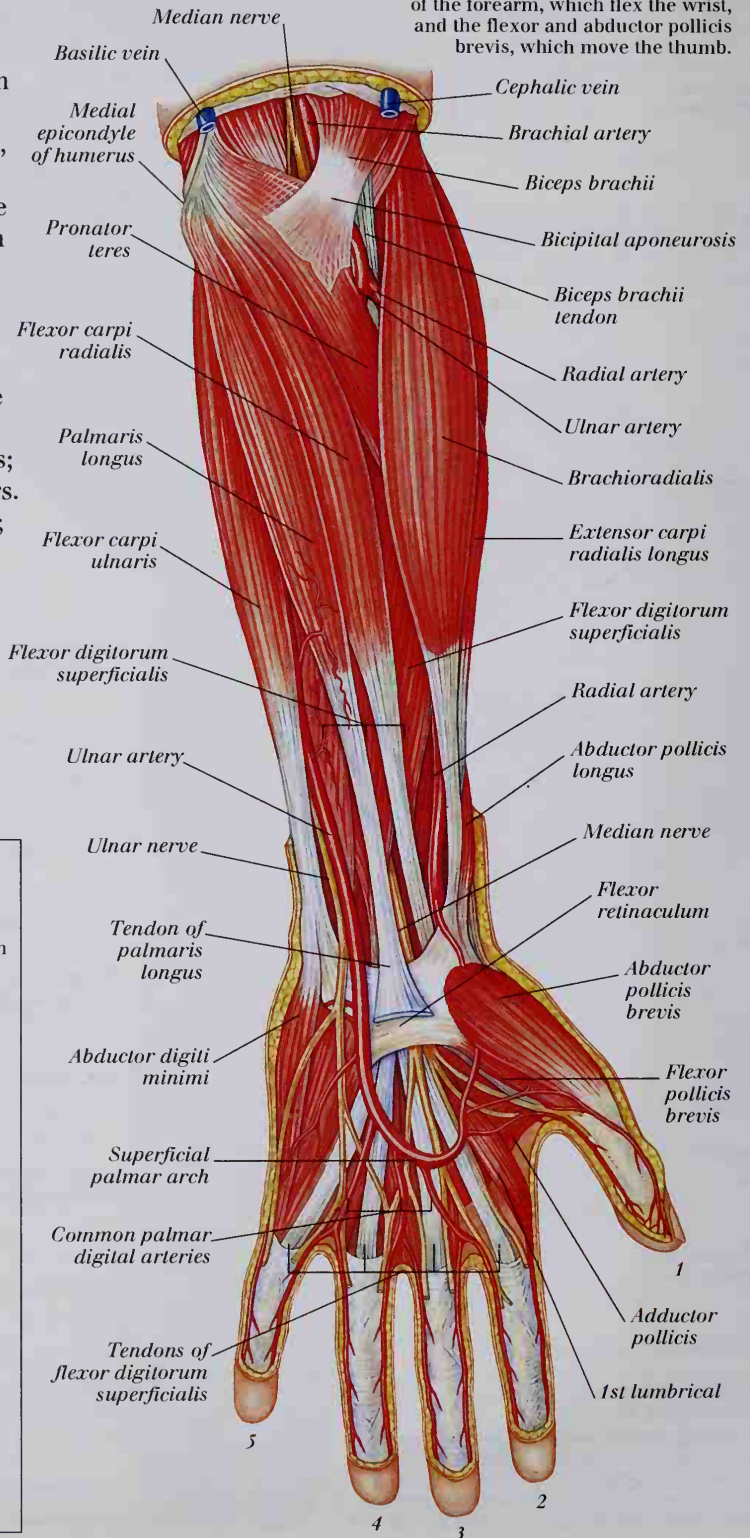

SUPERIOR VIEW OF BONES OF THE HAND

The long phalanges, which shape the fingers of the hand, together with the bones of the metacarpus (palm) and carpus (wrist), enable the hand to perform gripping movements. These range from the precision grip used when holding a pen to the power grip used when making a fist.

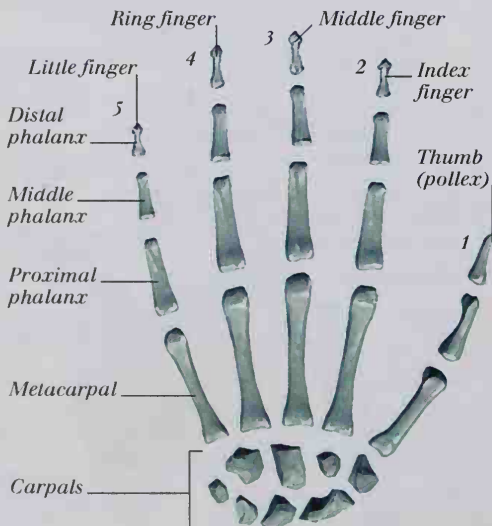

POSTERIOR VIEW OF SUPERFICIAL MUSCLES

The radial nerve controls the action of the extensor muscles of the forearm, most of which extend the wrist. The extensor digitorum straightens the fingers, and the extensors pollicis brevis and longus extend the thumb.

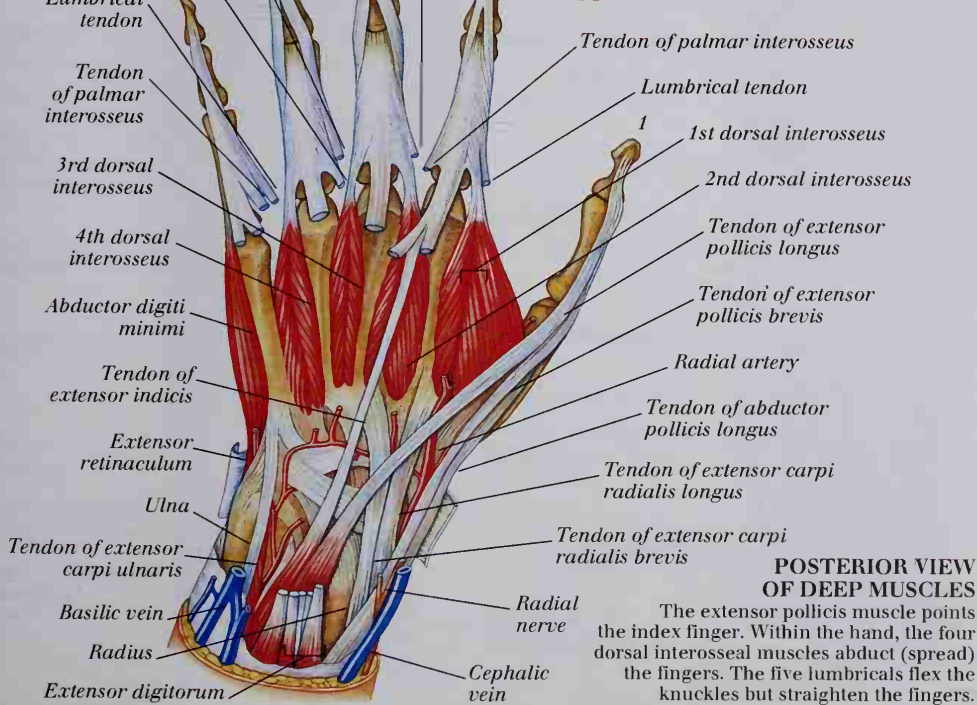
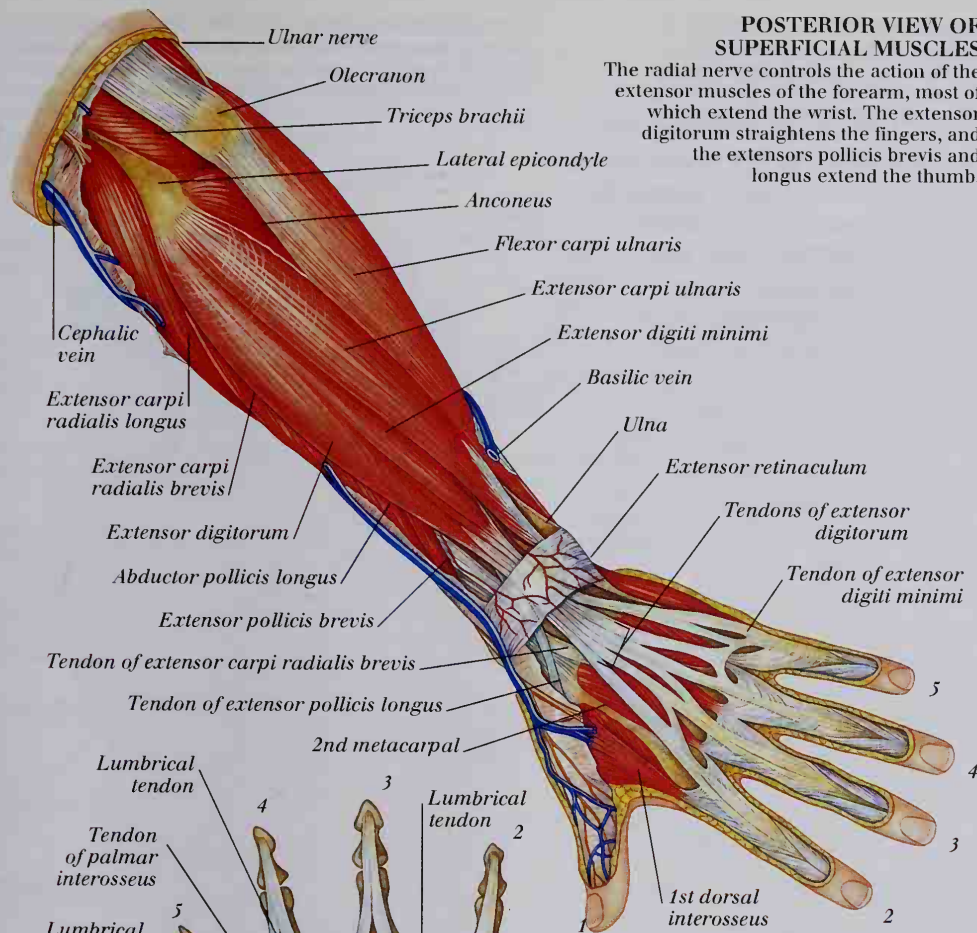

POSTERIOR VIEW OF DEEP MUSCLES

The extensor pollicis muscle points the index finger. Within the hand, the four dorsal interosseal muscles abduct (spread) the fingers. The five lumbricals flex the knuckles but straighten the fingers.

BONE GROWTH

NEWBORN

The cartilage framework that forms before birth is replaced by bone to form the skeleton. X rays show the presence of bone but not cartilage.

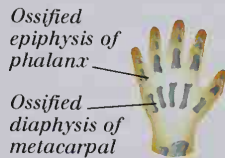

4-YEAR-OLD

The diaphysis (shaft) and epiphysis (head) have become ossified (changed to bone). The cartilage plate between them continues growing.

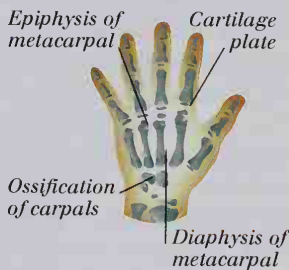

11-YEAR-OLD

By late childhood, most of the wrist bones are now formed, and the palm and finger bones have become longer.



20-YEAR-OLD

The palm, finger, and wrist bones of an adult are fully grown and ossified. Diaphyses and epiphyses have fused.

Phalanges and metacarpals are fully grown and extended

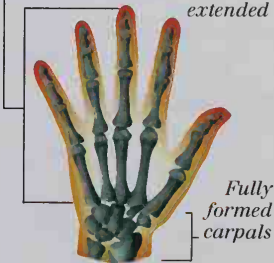

Thigh

THE THIGH IS THE REGION OF THE LOWER LIMB between the pelvis and the knee. It is supported by the femur (thigh bone), which articulates with the pelvis at the hip joint to permit the thigh to move in most planes. At the knee joint, the femur articulates with the tibia to permit flexion (bending) and extension (straightening) only. The thigh muscles are used for walking, running, and climbing. Anterior thigh muscles are divided into two groups: the iliopsoas and sartorius, which flex the thigh at the hip; and the rectus femoris, vastus lateralis, vastus medialis, and vastus intermedius (known collectively as the quadriceps femoris), which extend the leg at the knee. The major posterior thigh muscles, which consist of the biceps femoris, the semitendinosus, and the semimembranosus (known as the hamstrings) extend the thigh at the hip, and flex the leg at the knee. The gluteus maximus (buttock) muscle assists with the extension of the thigh during climbing and running. Blood is supplied to the thigh by the femoral artery, and removed by the femoral vein. The main nerves supplying the thigh muscles are the femoral and sciatic nerves.

ANTERIOR VIEW OF SUPERFICIAL MUSCLES

Most of the anterior thigh muscles straighten the leg and pull it forward during walking or running. The adductor longus and pectineus also pull the leg inward.

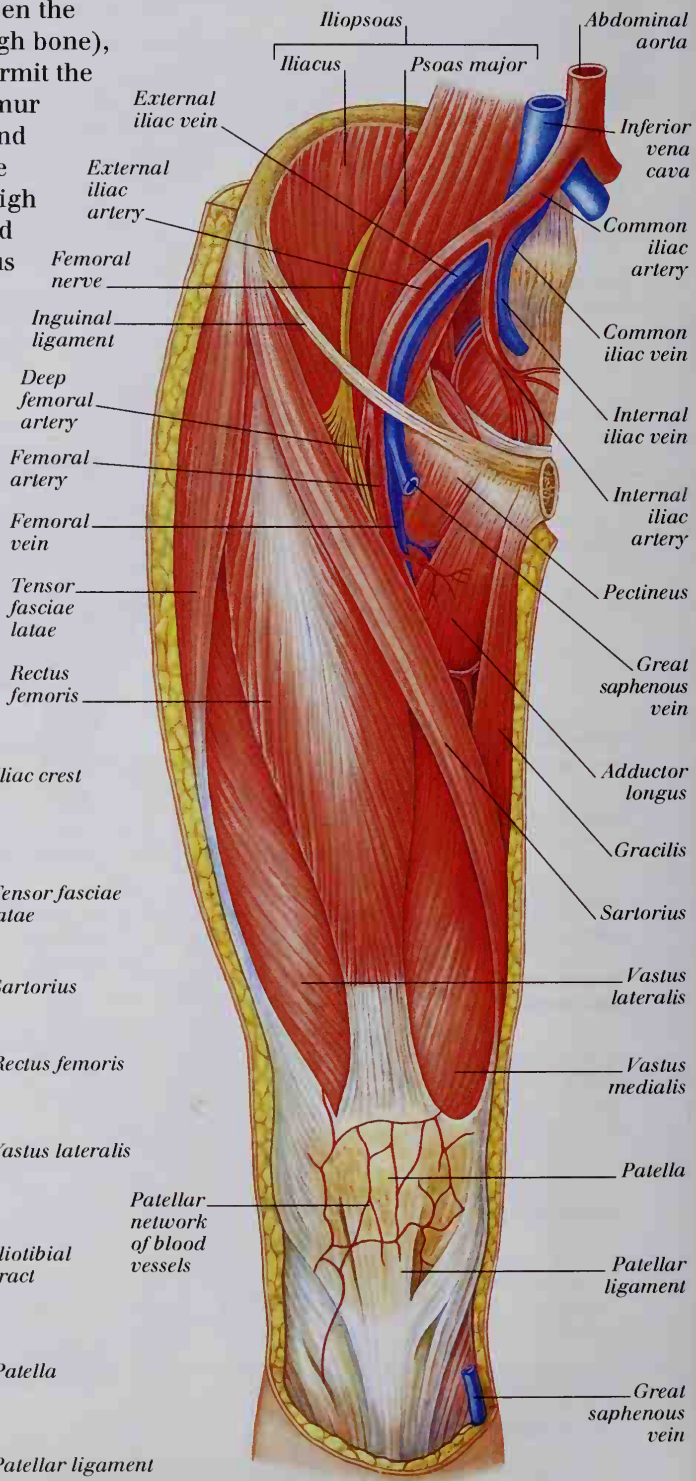

LATERAL VIEW OF SUPERFICIAL MUSCLES

The tensor fasciae latae muscle helps to steady the trunk on the thighs when a person is standing upright.

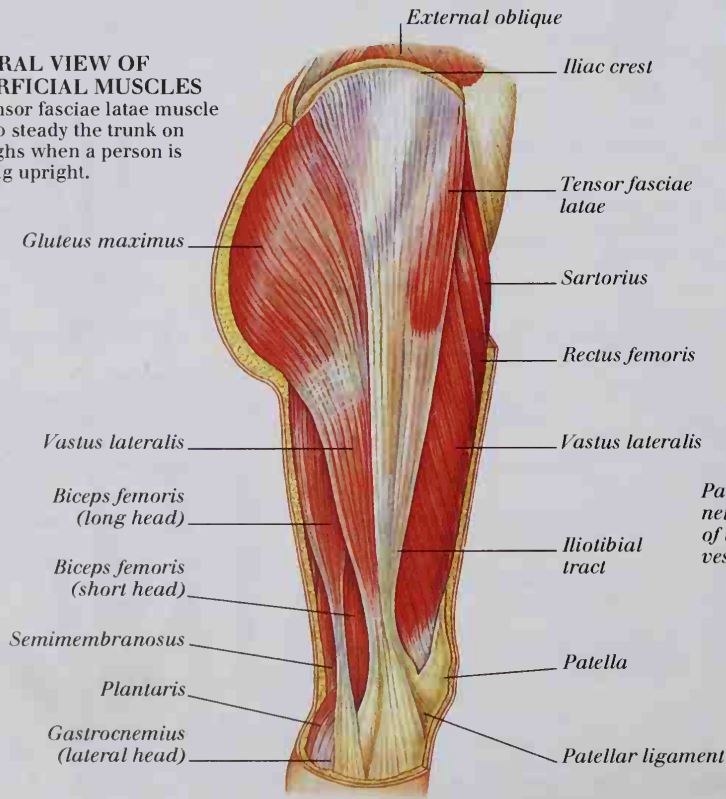

POSTERIOR VIEW OF SUPERFICIAL MUSCLES

The posterior thigh muscles produce the backswing of walking or running by bending the leg and pulling it backward. The gluteus maximus also steadies the pelvis, thus helping in the maintenance of posture.

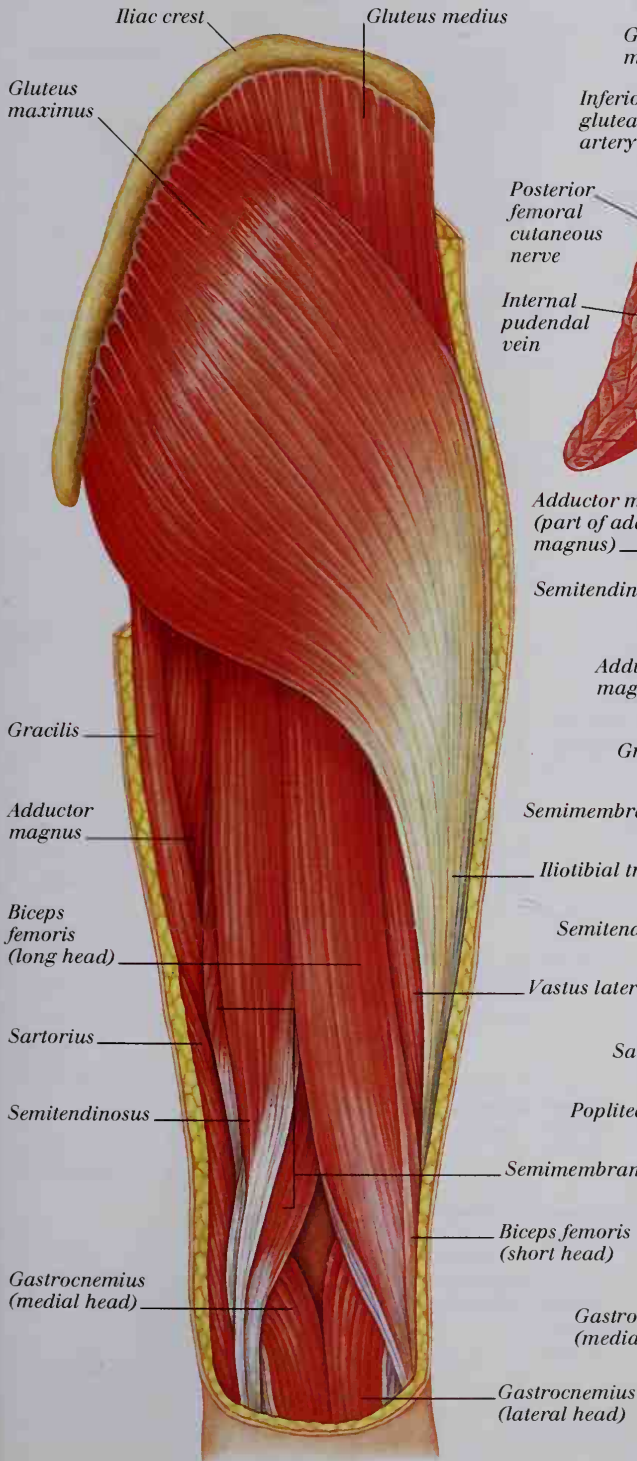

POSTERIOR VIEW OF DEEP MUSCLES

During walking, the gluteus medius holds the pelvis parallel to the ground when one leg is in motion in order to prevent a lurching gait. The gemellus, piriformis, and obturator internus stabilize the hip joint. The adductor magnus pulls the thigh inward.

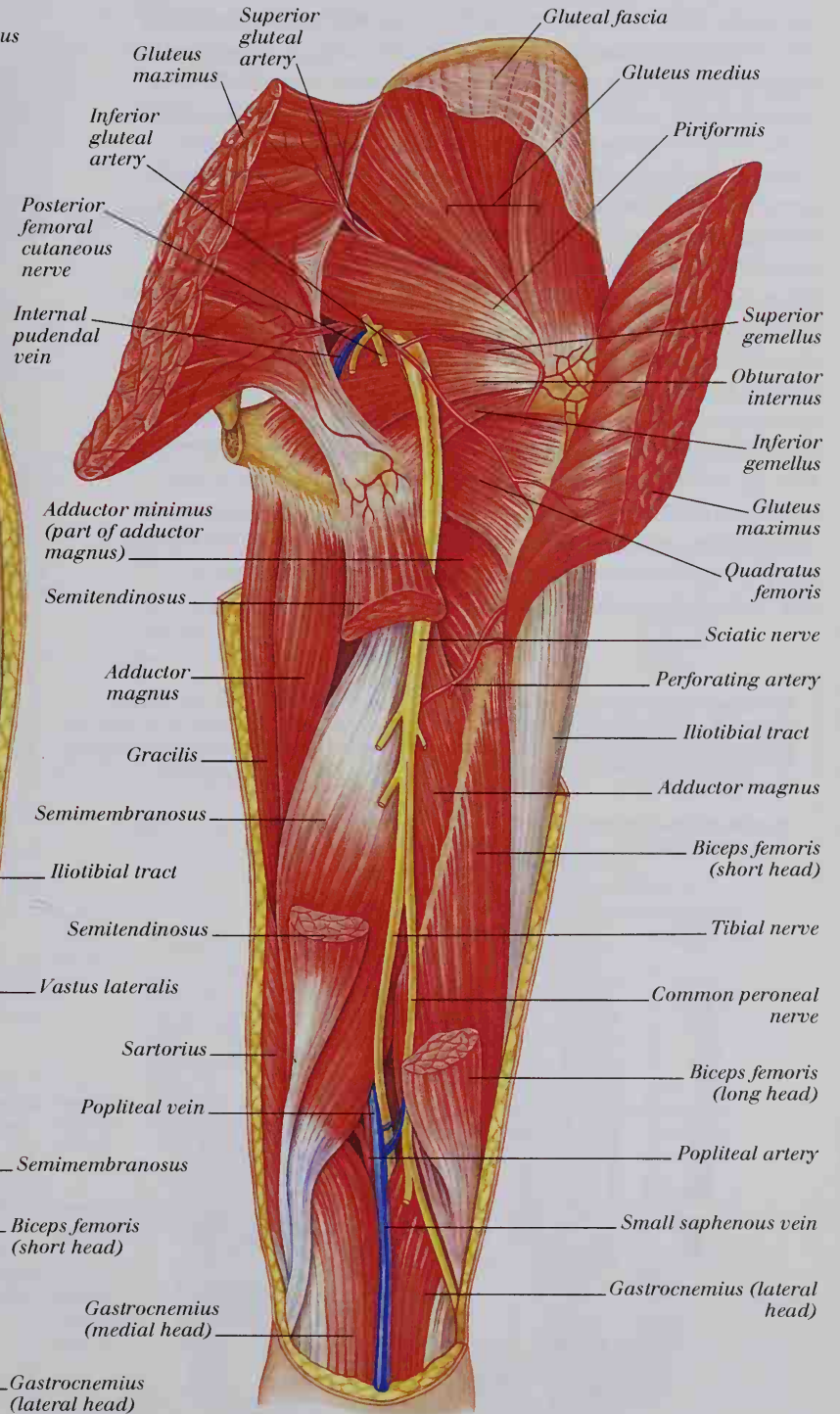

Lower leg and foot

ANTERIOR VIEW OF SUPERFICIAL MUSCLES
 The main function of the superficial muscles is to dorsiflex the foot, preventing the toes from dragging on the ground during walking.

THE FOOT IS A FLEXIBLE PLATFORM that supports and moves the body. The skeleton of the foot consists of 14 phalanges (toe bones); 5 metatarsals (sole bones); and 7 tarsals (ankle bones), 2 of which articulate with the tibia and fibula (leg bones) at the ankle joint. The anterior leg muscles – which include the tibialis anterior, extensor digitorum longus, extensor hallucis longus, and peroneus tertius – primarily dorsiflex the foot (bend it upward). The two extensor muscles extend (straighten) the toes and the big toe respectively. The posterior leg muscles – which include the gastrocnemius, soleus, tibialis posterior, flexor digitorum longus, and flexor hallucis longus – primarily plantar flex the foot (straighten the ankle), providing forward thrust during walking and running. The flexor muscles flex (bend) the toes and the big toe respectively. The muscles inside the foot help move the toes and support the arches. Blood is carried to the leg and foot by the anterior and posterior tibial arteries, and the peroneal artery; it is removed by the anterior and posterior tibial veins, and the great saphenous vein. The main nerves supplying the muscles of the leg and foot are the tibial nerve, and the peroneal nerve.

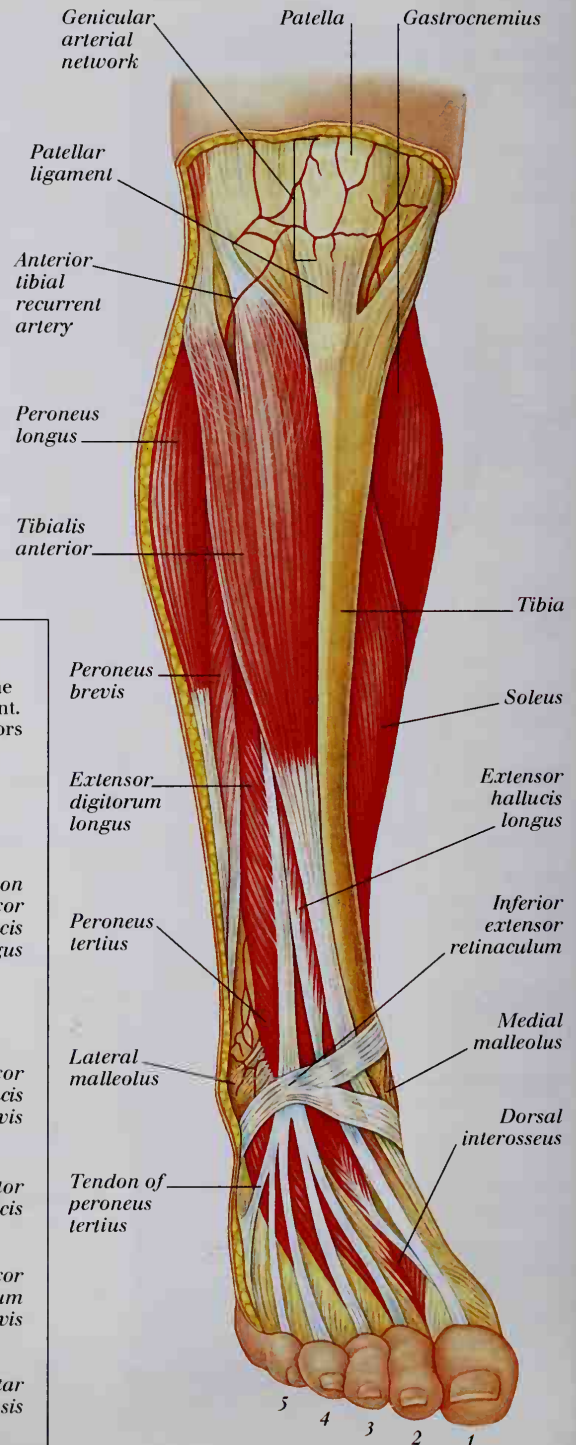

THE FOOT

The bones of the foot support the body on both flat and uneven surfaces, and form a springy base from which to push the body off the ground during walking, running, or climbing.

The primary actions of the muscles of the underside of the foot are to arch the foot and to stabilize it during movement. As the foot leaves the ground, the flexors bend the foot downward.

SUPERIOR VIEW OF BONES OF THE RIGHT FOOT

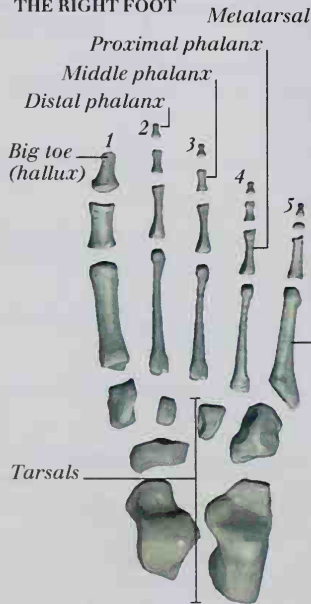

SUPERFICIAL MUSCLES OF THE SOLE OF THE RIGHT FOOT

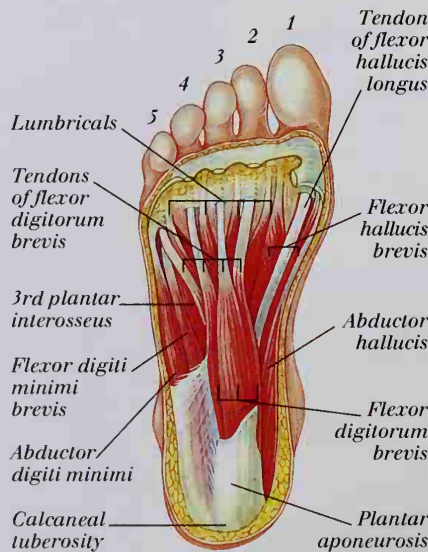

POSTERIOR VIEW OF SUPERFICIAL MUSCLES

The major superficial muscles – the gastrocnemius and soleus – act by pulling on the calcaneal (heel) bone to plantar flex the foot during walking or running.

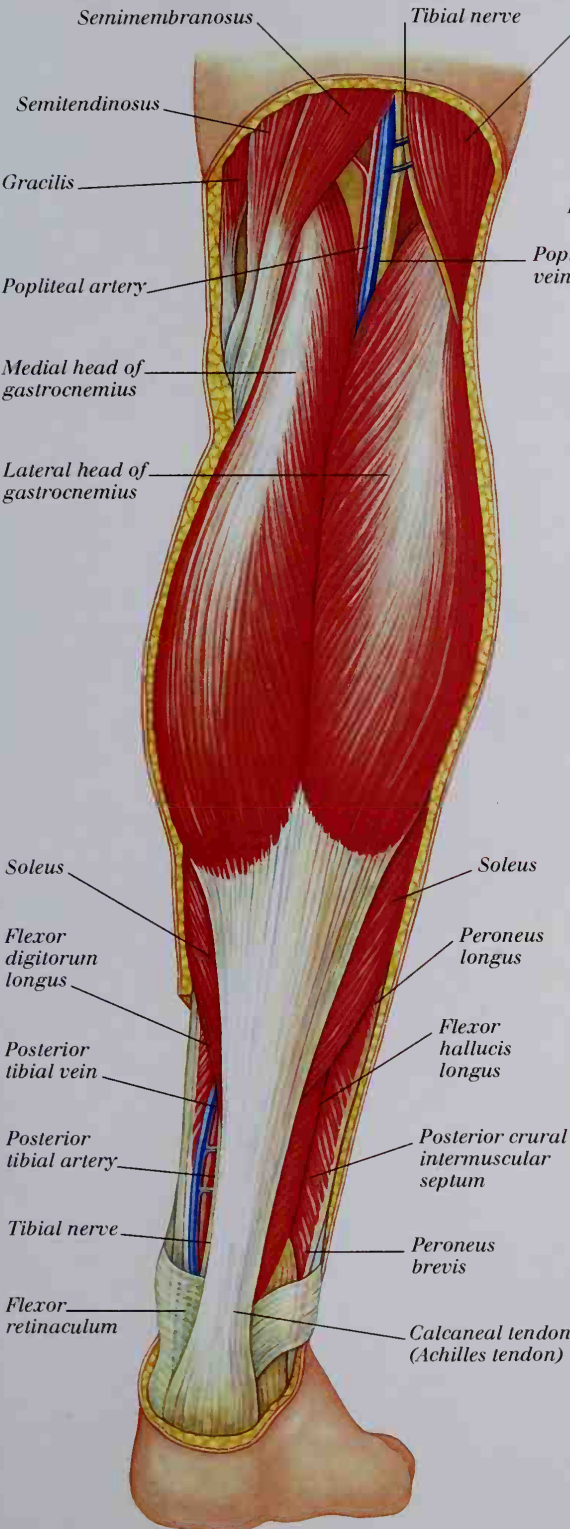

MUSCLES AND TENDONS OF ANKLE AND FOOT

Long tendons extend into the foot from the extensor digitorum longus and extensor hallucis longus muscles. These work to straighten the toes, with the assistance of the smaller extensor muscles inside the foot.

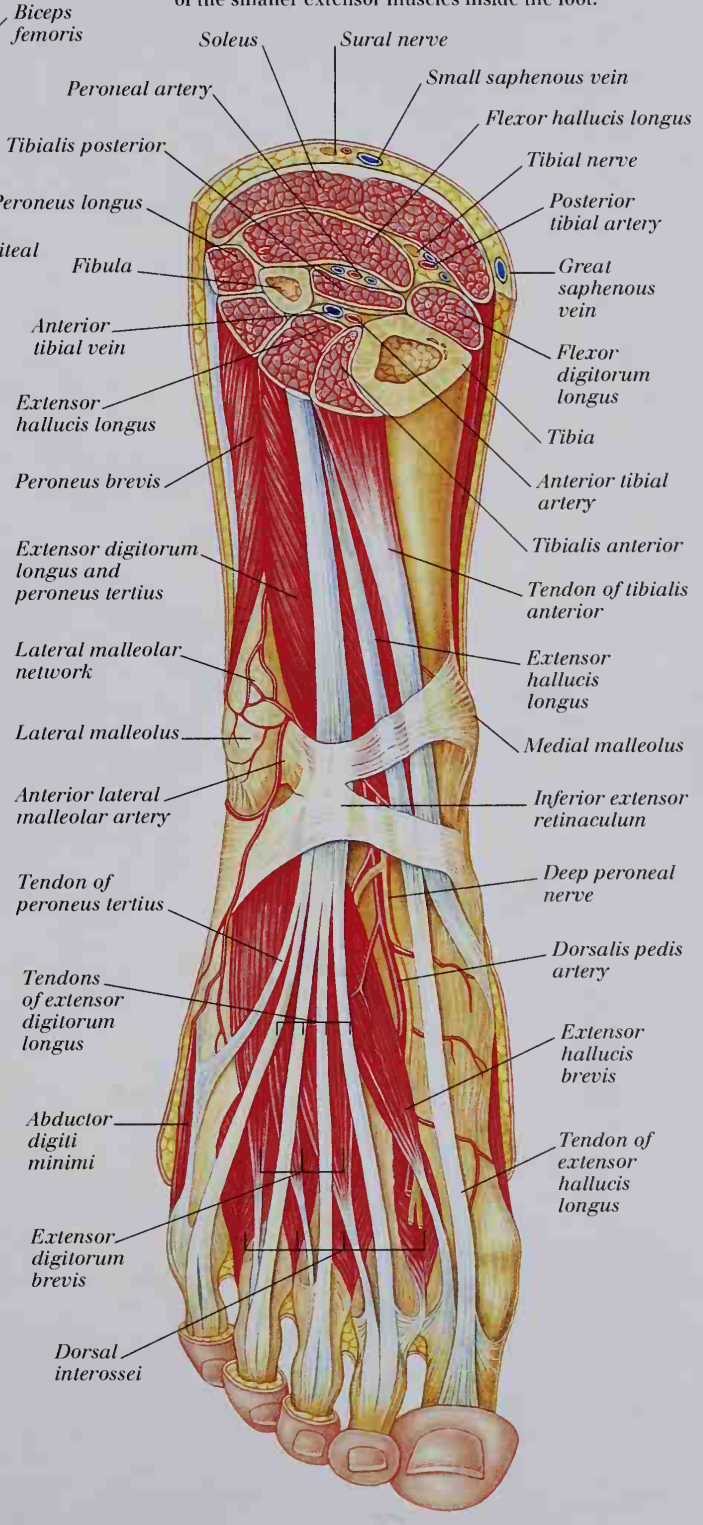

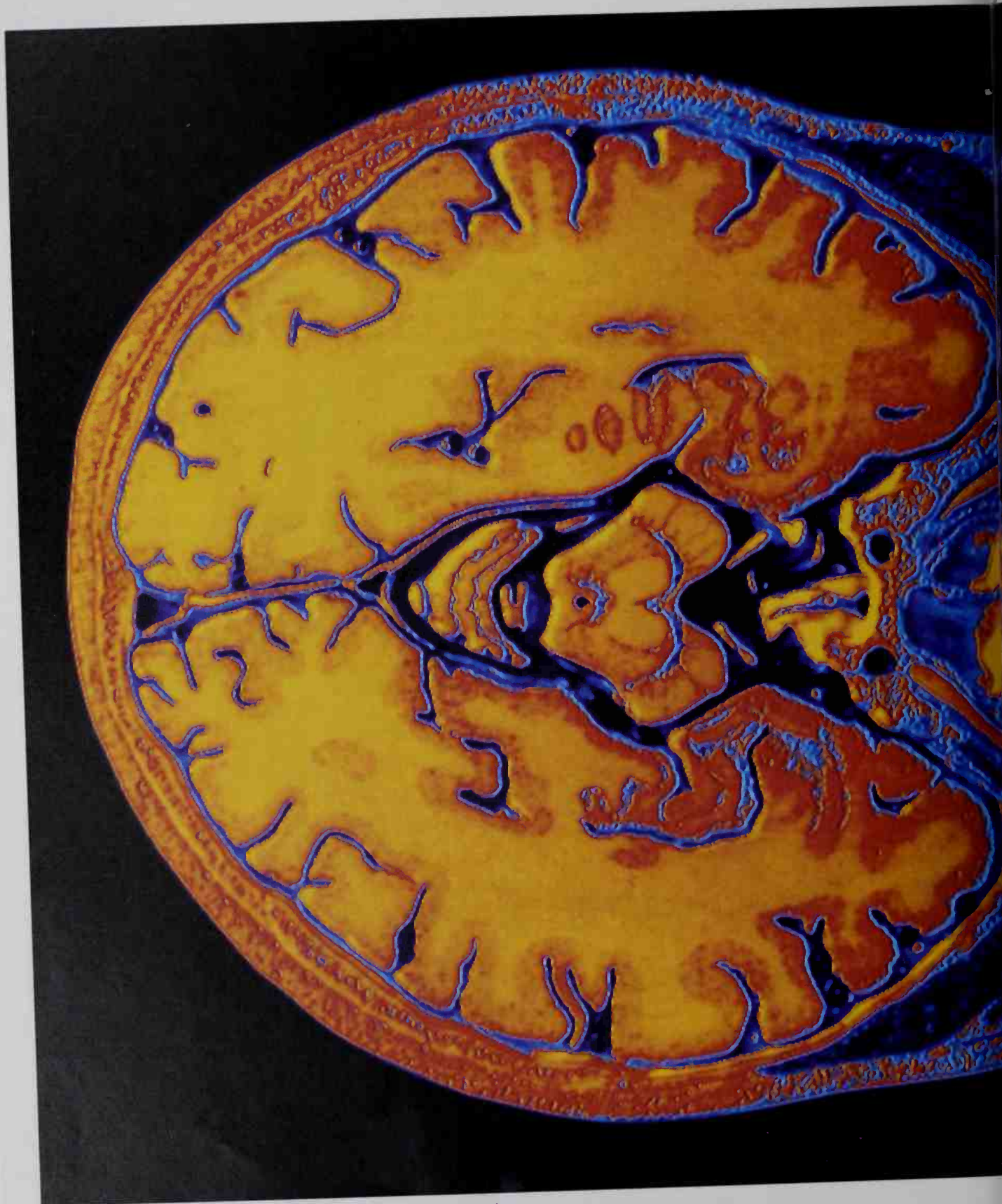

False-color Magnetic Resonance Imaging (MRI) scan of a human head

MEDICAL SCIENCE

DISCOVERING MEDICAL SCIENCE.....	236
DIAGNOSIS	238
MEDICAL IMAGING 1	240
MEDICAL IMAGING 2	242
EMERGENCY CARE	244
SURGERY	246
MINIMALLY INVASIVE SURGERY	248
TRANSPLANTS	250
ARTIFICIAL BODY PARTS	252
DRUGS AND DRUG DELIVERY	254
PREGNANCY AND CHILDBIRTH	256
INFECTION AND DISEASE	258
THE IMMUNE SYSTEM	260
GENETICS AND MEDICINE	262

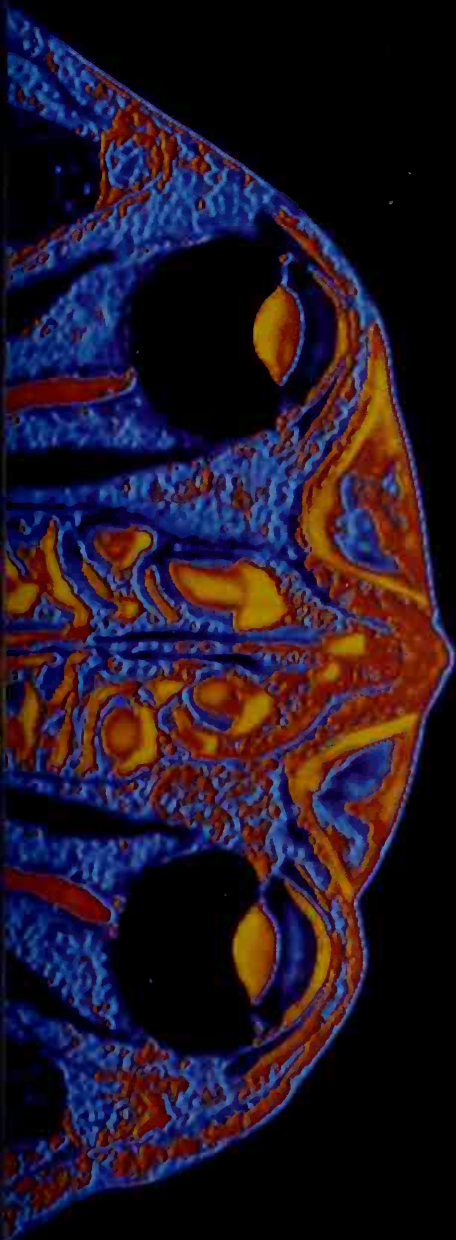

Discovering medical science

THE SCIENCE OF MEDICINE is the science of human health. It has always had close links with anatomy and life science, and more recently with physics and chemistry. Medical science includes areas not covered here, including dentistry (concerning teeth and gums) and psychiatry (concerning mental, emotional, and behavioral disorders). Surgery is considered to be separate from general medicine.

FOLK MEDICINE

Traditional, nonscientific medicine is usually called “folk medicine.” In the folk medicine of many cultures, it is believed that illness is due to the influence of demons and other evil spirits. Despite this, even ancient folk medicine often involved the use of herbal remedies and even fairly complex surgery. An example of prehistoric surgery is the process of trepanning. This involved drilling a small hole in the skull, thus allowing “evil spirits” to leave the brain. In the ancient civilizations of India and China, medical practice was well organized, but still had little scientific basis. Physicians (doctors) carefully recorded diagnoses of a host of different symptoms, but did not understand physiology well enough to treat these symptoms effectively.

A BALANCED VIEW

In both India and China, from a few hundred years before Christ, medicine depended upon the concept of balance. The body was thought to consist of a small number of elements or “principles.” An illness was caused by an imbalance of these principles. The Chinese system assumed that health depends upon the balance of two principles – “yin” and “yang.” Hindu philosophers developed a similar system based on the balance of three elements. The ancient Greeks believed that the body consisted of four humors – blood, phlegm, black bile, and yellow bile – based on the four-elements theory that the Greeks applied to matter in general.

MEDICINE IN ANCIENT GREECE

There were few groundbreaking practical developments in ancient Greek medicine, although many Greek physicians were expert anatomists. Despite their expertise, they could not make successful diagnosis of, nor effectively treat, many diseases because their knowledge of anatomy was gained

by examining animals such as apes and pigs. One valuable contribution that the Greeks made to medicine was the Hippocratic method. This encouraged careful observation of symptoms and a professional approach to medicine. It also included an oath, a form of which is still taken by medical doctors today.

HOSPITALS AND PUBLIC HEALTH

Great importance was attached to health throughout the Roman Empire. For example, water supplies, drainage, and public baths were features common to all large towns. The Roman Empire also had the first hospitals. During the Middle Ages, several great hospitals were developed by scholars and physicians. There was still little, however, that could truly be called medical science. There was no real understanding of how the body works, for example, and no technological aids to diagnosis. Medical science did not begin to develop until the scientific revolution of the Renaissance.

ANATOMY AND MEDICINE

Treatment of disease or injury during the Renaissance was primitive by modern standards, but the rise of the scientific method enabled anatomists and physicians to make real progress. In Italy, **Andreas Vesalius** corrected many of the inaccurate anatomical observations that had been made by earlier anatomists. This improved knowledge enabled surgeons to operate more efficiently. The knowledge that the blood circulates continuously around the body is essential to any scientific approach to medicine. **William Harvey** discovered blood circulation during the 1620s. The functions of the body’s organs were slowly figured out, helped by the invention of the microscope in the 17th century. Despite rapid advances in many areas, the real causes of disease could only be speculated upon until the development of the germ theory in the 19th century.



ACUPUNCTURE

Practitioners of acupuncture believe that energy flows along pathways called meridians. They insert needles at points along the meridians in the belief that it allows energy to enter, leave, or be diverted around the body. This 18th-century bronze figure acts as a guide to insertion points.

THE GERM THEORY

The development of a vaccine for the killer disease smallpox during the 18th century was a scientific breakthrough. But **Edward Jenner**, who perfected the technique in the 1790s, did not really understand why it worked. In 1840, **Friedrich Henle** published the theory that infectious diseases were caused by microscopic living organisms. Evidence in support of this “germ theory” came during the 1850s, as one species of microorganism was observed in the blood of a group of people suffering from the same disease. More and more diseases were attributed to particular microorganisms – normally either rod-shaped (bacillus) or spherical (coccus) bacteria. The work of **Paul Ehrlich** led to the development of chemotherapy. His drugs killed bacteria but left patients unharmed. The first antibiotic was penicillin, discovered in 1928 by **Alexander Fleming**. Antibiotics are substances produced by some bacteria or fungi that are harmful to pathogenic (disease-causing) bacteria or fungi in the body.

TISSUE STAINING

Some synthetic dyes will stain certain types of biological tissue but leave the host organism untouched. **Paul Ehrlich** discovered that he could safely treat certain conditions by “attaching” an arsenic compound to the synthetic dye molecule.



ANESTHETICS AND ANTISEPTICS

Other chemical or biological substances used in medical science include anesthetics and antiseptics. For hundreds of years, alcohol and opium were used during surgery to combat the pain of incision (cutting into the body). The first really effective anesthetic was ether, first used in 1846. In addition to pain, the other problem during surgery was infection. **Joseph Lister** applied the germ theory to the prevention of infection during operations. He introduced the first antiseptic – carbolic acid – in 1867. The discovery of blood types in 1900 made possible effective blood transfusions, which further improved surgical success rates.

20TH CENTURY

Medical science since the beginning of the 20th century has benefited from medical physics, which has provided new and better means of diagnosis and treatment. The first X-ray imaging of the human body took place in 1895.

During the late 20th century, other forms of medical imaging were developed. They include ultrasound, computerized axial tomography (CAT, 1970s), and magnetic resonance imaging (MRI, 1980s). Advances in molecular biology – the science that investigates biological processes at the molecular level – have also been important in both diagnosis and treatment. They have made possible an understanding of the immune system and genetic testing for inherited diseases. It has also led to an understanding of viruses, the cause of many diseases. Gene therapy (1980s), the treatment of diseases caused by “defective” genes, has given new hope in the fight against conditions such as the lung disease cystic fibrosis. Insertion of the “correct” gene into the patient can often give the patient a more healthy lung.

EARLY SURGERY

This skull, which dates from around 2000 BC, has three trepanned holes. These holes were made using a crude, drill-like instrument. Some people survived the process of trepanning, including this individual. This can be deduced from the signs of healing around the edges of the holes.

TIMELINE OF DISCOVERIES

	2500 BC	– The use of surgery is well documented in Egypt
Indian physician Sushruta performs the first cataract operation	– 500 BC	
	400 BC	– Greek physician Hippocrates develops the professional outlook on medical practice, encouraging its separation from religion
The <i>Ayurveda</i> is compiled. It is the basic Hindu medical encyclopedia for many hundreds of years	– 50 BC	
Roman physician Galen suggests using the pulse as a diagnostic aid	– AD 170	
	AD 20	– Roman scholar Celcus writes an important medical encyclopedia
	1540s	– French surgeon Ambroise Paré suggests use of soothing ointment for treatment of wounds. He also introduced ligatures (tying of blood vessels) instead of cauterization (heat treatment) after amputation
Iatrophysics and iatrochemistry gain popularity. These schools of thought see the body as a relatively simple “machine”	– 1620s	
	1628	– English physician William Harvey publishes his discovery of the circulation of the blood
English surgeon John Hunter advances the professional nature of surgery and pioneers the art of skin grafting	– 1770s	
	1796	– English surgeon Edward Jenner discovers the scientific principles of vaccination
American surgeon Charles Jackson discovers that ether is an anesthetic	– 1841	
	1867	– English surgeon Joseph Lister publishes his results concerning the use of the first antiseptic, carbolic acid
German bacteriologist Robert Koch establishes the link between disease and microorganisms	– 1870s	
	1900	– Austrian-born physician Karl Landsteiner discovers the ABO blood group system
Dutch physician Willem Einthoven invents the electrocardiogram, a device that monitors a patient's heartbeat	– 1905	
	1910	– German bacteriologist Paul Ehrlich produces the first synthetic drug. It is Salvarsan 606 (arsphenamine) and is effective against syphilis
Scottish bacteriologist Alexander Fleming discovers the antibiotic penicillin	– 1928	
	1955	– American virologist Jonas Salk develops the first effective vaccine for poliomyelitis
The first successful heart transplant is performed by South African physician Christiaan Barnard	– 1967	

Diagnosis

A MEDICAL CONDITION MAY BE DIAGNOSED by the examination of a patient's signs and symptoms; this must be done if the correct care and treatment is to be given. Diagnosis usually begins with the family physician (general practitioner), who may carry out a series of physical or clinical tests. The doctor will start by asking the patient to describe their symptoms. They will also compile a case history that includes personal and family medical histories. Standard tests, which can be performed in the doctor's clinic, may also be carried out. The nervous reflexes, eyes, ears, nose, and throat can be checked, and the body temperature and blood pressure taken. The doctor may also use a stethoscope to listen to the internal noises of the body, such as heartbeat, pulse, and breathing. If necessary, a body fluid or tissue sample can be sent to a laboratory for further analysis, and the patient may be referred for further investigations, such as an endoscopic examination (see pp. 248-249) or an X ray or scan (see pp. 240-245).

LISTENING TO BODY SOUNDS

Auscultation is the diagnostic technique of listening to the internal sounds of the body, usually with a stethoscope. The diaphragm or bell-shaped part of the stethoscope is pressed against the patient. Sounds from within the body, for example in the lungs, heart, joints, and stomach, are conveyed along hollow tubes to the examiner's ears.

VIEWING PARTS OF THE BODY

Looking into the eyes, ears, nose, and throat can reveal signs of infection and abnormalities. It can also give an indication of general health. Attachments can be clipped onto a handle that provides a light source to illuminate the area being examined. The

otoscope is used to look inside the ears or nose (when the nasal speculum is attached); the laryngoscope, with attachments, is used to view the throat. The ophthalmoscope can identify eye abnormalities and give an indication of the general health of the blood circulation system.



Binaural stethoscope has earpieces, which help to block out external sounds

Hollow, plastic tube conveys sound waves

End can be reversed by twisting; bell-shaped end or diaphragm can be used

Bell-shaped side picks up low-pitched sounds and murmurs

Diaphragm, on reverse side, picks up high-pitched noises

VIEWING PARTS OF THE BODY

Looking into the eyes, ears, nose, and throat can reveal signs of infection and abnormalities. It can also give an indication of general health. Attachments can be clipped onto a handle that provides a light source to illuminate the area being examined. The

otoscope is used to look inside the ears or nose (when the nasal speculum is attached); the laryngoscope, with attachments, is used to view the throat. The ophthalmoscope can identify eye abnormalities and give an indication of the general health of the blood circulation system.



Rotating set of magnifying lenses for examining the eye

Various head attachments screw on here

Light source tip

LARYNGOSCOPE HEAD

Handle containing batteries for light source

OPHTHALMOSCOPE

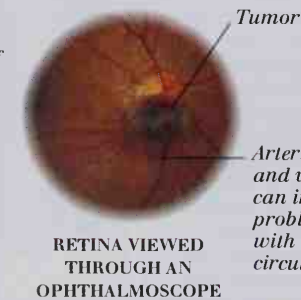

RETINA VIEWED THROUGH AN OPHTHALMOSCOPE

Tumor

Arteries and veins can indicate problems with circulation

TONGUE DEPRESSOR FOR LARYNGOSCOPE

MIRROR HEAD

Angled mirror to reflect image

Flat end for pressing down tongue

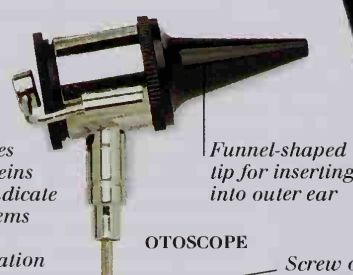

OTOSCOPE

Funnel-shaped tip for inserting into outer ear

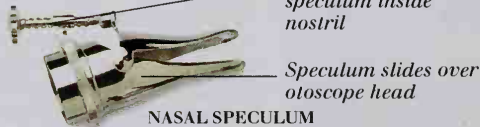

NASAL SPECULUM

Screw opens speculum inside nostril

Speculum slides over otoscope head

BODY FLUIDS AND TISSUE ANALYSIS

In order to establish or confirm a diagnosis, it may be necessary to remove body fluids or tissues for further analysis in a medical laboratory. The instruments below are used for obtaining cell samples. The cytology brush gently rubs cells off moist body surfaces, such as the inside of the mouth. The wooden spatula is designed to obtain cells and fluid from the cervix (neck of the womb). Most samples are immediately placed into sterile specimen tubes, labeled, and sent to the laboratory.



Bristles gently rub away cells

Blunt end for scraping off cells

Color-coded label gives patient and sample information

Chemicals stabilize or preserve sample

DISPOSABLE SPECIMEN TUBE

MEASURING BLOOD PRESSURE

This procedure measures the pressure waves produced in the arteries with each contraction of the heart. It can reveal problems with the heart and blood vessels. A cuff is inflated around the upper arm until a pulse cannot be felt in the wrist. As it is slowly deflated, the doctor listens for a pulse in the artery at the elbow. Readings are taken at systolic (maximum) pressure - when the blood is first heard to force its way through - and diastolic (minimum) pressure - when the blood flow is uninterrupted.

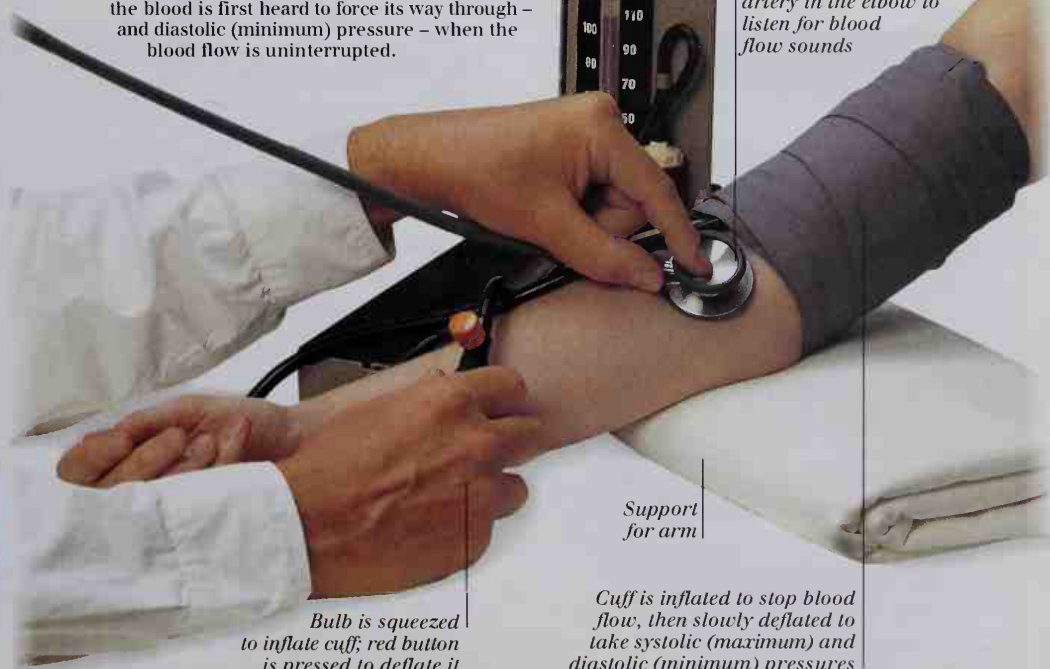

CYTOLOGY BRUSH SPATULA

Bulb is squeezed to inflate cuff; red button is pressed to deflate it

Support for arm

Cuff is inflated to stop blood flow, then slowly deflated to take systolic (maximum) and diastolic (minimum) pressures

MEASURING TEMPERATURE

A high temperature may be an indication that the body is fighting infection, it can be monitored using a thermometer. Traditional clinical thermometers consist of a glass tube with a bulb of mercury at one end. Electronic versions have a thermocouple in the heat sensitive end and a digital readout, which makes them easier and safer to use.



Temperature-sensitive end

Digital temperature readout

Reset button

VISION TESTS

Abnormalities in vision can be detected using a variety of tests. Sharpness of vision may be tested by reading letters from the Snellen chart. The Ishahara test uses dots of related colors to test for color blindness. Here, a pattern of green dots can be seen on a background of red, orange, and yellow dots.

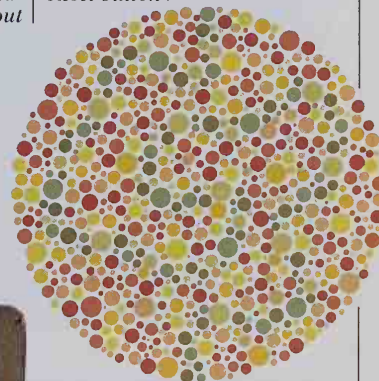

Readings are taken from the mercury scale

Sphygmomanometer scale, measured in millimeters of mercury (mm Hg)

Column of mercury measures air pressure in cuff, which reflects blood pressure inside artery

Stethoscope is placed over artery in the elbow to listen for blood flow sounds

Medical imaging 1

SOUND AND ELECTROMAGNETIC RADIATION can be used to create visual images of the body's interior without the need for surgery. Medical imaging is used for **diagnostic** reasons and to check on the effects of treatment and surgery. With the development of computers, technology has advanced greatly, and there are now various techniques used to produce images. In ultrasound scanning, **high frequency sound waves** transmitted through the body are absorbed and reflected to different degrees by different body tissues. It is considered a safe method of imaging, as it does not use **radiation**. X-ray imaging is the oldest form of imaging and is still the most commonly used in most clinical cases. Short-wave electromagnetic rays are passed through the body and detected, making a photographic-type image. This image may be of limited use, and exposure to radiation can damage cells. Computerized tomography (CT) scanning combines the use of multiple X-ray beams and detectors, with a computer that can create more detailed cross-sectional or three dimensional images.

ULTRASOUND IN PREGNANCY

Ultrasound scanning is generally considered to be safer than certain types of X-ray imaging. For this reason, it is often used to provide images of the fetus during pregnancy. These images can reveal abnormal development and can also be used to tell if the fetus is male or female. In many countries an ultrasound scan is part of routine prenatal testing. It is usually done about 16-18 weeks into pregnancy.



ECHOCARDIOGRAPHY

HOW ECHOCARDIOGRAPHY WORKS

Echocardiography has become an important diagnostic tool for most cardiologists (heart specialists). It uses ultrasound to visualize the internal structure of the heart and its movements. The emitter in the transducer produces pulses of ultrasound waves, which are beamed painlessly into the body. Different densities of organs or tissues absorb the waves or reflect them as echoes; these are picked up by the transducer's receiver. As the transducer is moved over the skin, the strength and time delay of the returning echoes are analyzed by a computer and an image of the heart is built up.

Left ventricle Right ventricle Right atrium Left atrium



ECHOCARDIOGRAM OF THE HEART

Echocardiography shows the heart beating "live" in real time. Pictures of the moving heart can be recorded on video for further analysis. These images are useful for detecting defects in the heart chambers and valves.

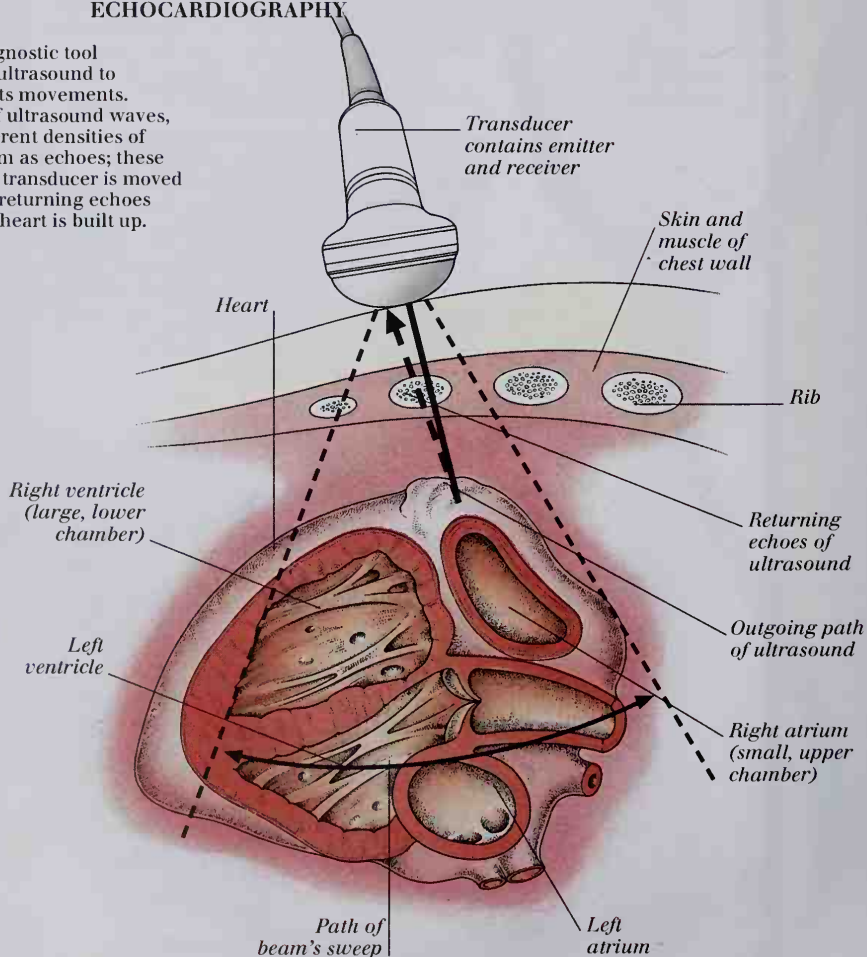

X-RAY IMAGING

An X-ray image is a shadow picture showing the shape and density of body parts. Plain X rays are the simplest, and are used for diagnosing bone and joint disorders. Very dense tissue – bones and cartilage – is revealed against a background of less dense tissue. Low-power X rays distinguish between abnormal, dense tissue – tumors – and the surrounding normal, less dense tissue. In this way, mammograms are used to screen for unusual growths in breasts. Contrast X rays use a contrast medium, such as barium or iodine, which shows up well on X ray. The medium may be swallowed (barium meal) or injected into blood vessels (angiography) in order to highlight blockages, growths, or ruptures.

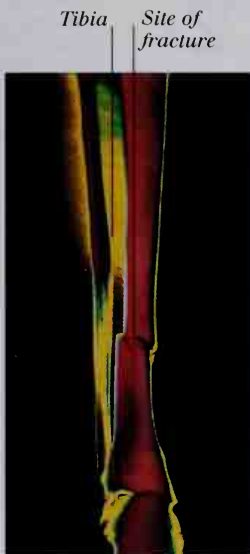

PLAIN X-RAY OF A LEG



MAMMOGRAM



ANGIOGRAM OF THE BRAIN

COMPUTERIZED TOMOGRAPHY (CT) SCANNING

HAVING A CT SCAN

A sliding table moves the person being scanned into a large, circular opening in the machine. As the person lies still on the table, the X-ray source rotates within the scanner and sends out a succession of narrow, low-power X-ray beams at different angles through the body. Detectors on the opposite side pick up the beams, which are weakened by differing amounts by the tissues they pass through, and send signals to a computer. This translates the information provided into a two-dimensional "slice" through the body, which is displayed on a screen.

Table slides through machine between scans to build up a "slice-by-slice" image of the body

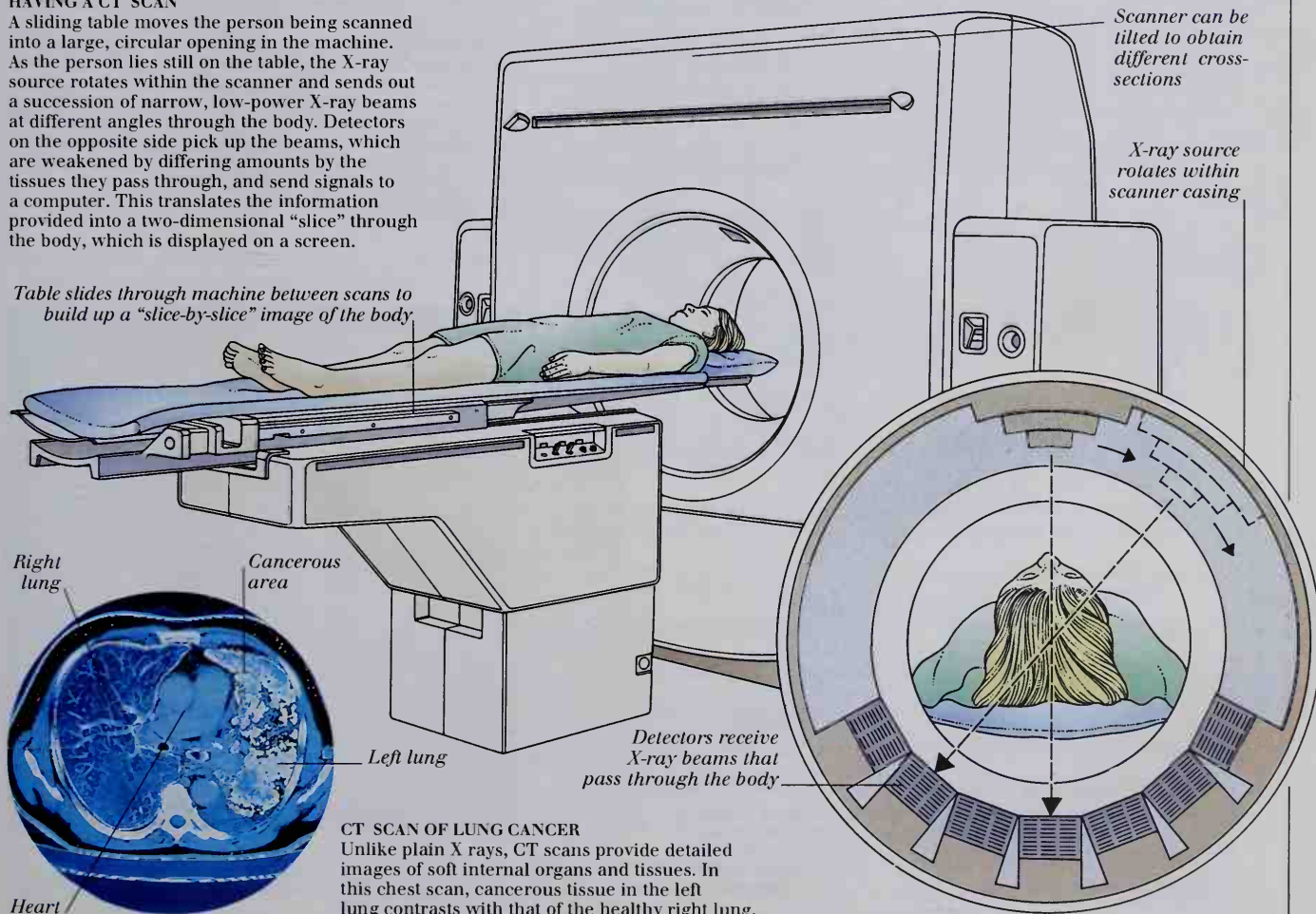

CT SCAN OF LUNG CANCER

Unlike plain X rays, CT scans provide detailed images of soft internal organs and tissues. In this chest scan, cancerous tissue in the left lung contrasts with that of the healthy right lung.

Medical imaging 2

CONTINUED DEVELOPMENT OF COMPUTERS and the desire for safer, more detailed ways of imaging the body have led to scientists developing new methods of medical imaging. Magnetic resonance imaging (MRI) uses radio waves in a powerful magnetic field. This produces highly detailed images of tissues within the body, especially of those with a high fat or water content, such as the brain. It can be used to diagnose a range of diseases – including cancer – and can also enable doctors to monitor degenerative disorders of the central nervous system, such as multiple sclerosis. In radionuclide scanning, a radioactive substance is introduced into the body, and the radiation given off is detected by a special camera. Positron emission tomography (PET) is a form of radionuclide scanning that uses computers to produce images that reflect the function of tissues as well as their structure. One of the main uses of PET has been to study the brain, as it can provide valuable information about brain function in mental illnesses.

HAVING AN MRI BRAIN SCAN

A sliding table moves the patient into a large magnet where the scan takes place. The image can be viewed on the scanner's computer screen, which is shielded from the magnetic field by a partition.



HOW MAGNETIC RESONANCE IMAGING (MRI) WORKS

Within the body's water molecules, hydrogen nuclei usually spin randomly around magnetic axes pointing in all directions. The intense magnetic field produced by the electromagnet in the MR scanner causes these nuclei to line up in the same direction as the polarity of the electromagnetic waves emitted. A pulse of radio frequency energy then knocks them out of alignment and causes them to wobble. As they realign themselves, they emit their own weak radio waves, which are picked up by detectors and analyzed by a computer.

Nucleus spins randomly around magnetic axis

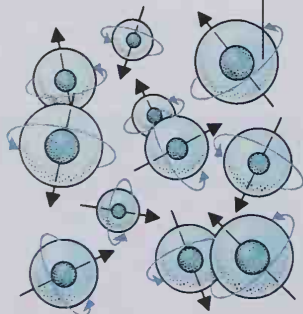

HYDROGEN NUCLEI IN THE BODY'S WATER MOLECULES

Magnetic poles in nucleus point in same direction

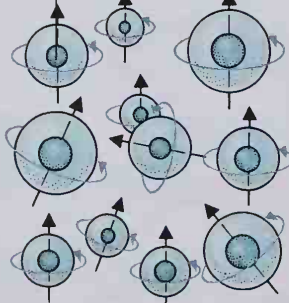

HYDROGEN NUCLEI AFFECTED BY ELECTROMAGNETIC WAVES

Pulse of radio frequency energy

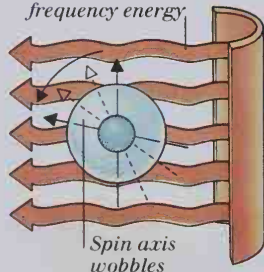

PULSE OF RADIO FREQUENCY CAUSES SPIN AXES TO WOBBLE

Spin axis returns to normal

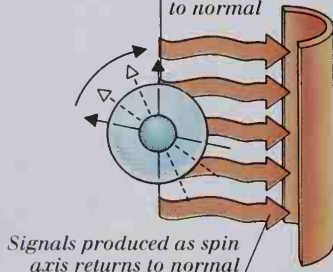

SPIN AXIS SENDS OUT SIGNALS AS IT RETURNS TO NORMAL

MRI SCAN OF THE BRAIN

MRI provides clear images of parts of the body that are surrounded by dense bone, making it particularly valuable for studying the brain and spinal cord. It is also useful for showing small details of soft tissues, such as nerves and blood vessels. It works by imaging different body tissues according to the density of their hydrogen atoms, hydrogen being present in the body's most common substance, water (H₂O), and also in many other body chemicals. Tissues with a high water content, such as fat, show up brightest on the image. This section, or slice, through the head shows the nerve tissue of the brain in great detail. The wrinkled cerebrum – where higher thought processes and consciousness are centered – can be seen at the top.

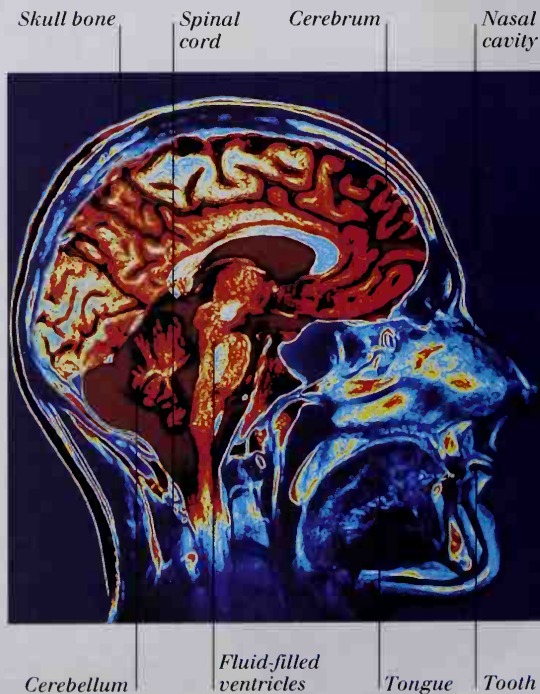

RADIONUCLIDE IMAGING

HAVING A POSITRON EMISSION TOMOGRAPHY (PET) SCAN

During a PET scan, a radiation source is temporarily introduced into the body. This source is a radionuclide, called a radioisotope – a specially manufactured, radioactively tagged chemical – which can be injected, swallowed, or inhaled. Within the body, this takes part in a biochemical process, concentrating in tissues that are more metabolically active. A ring of detectors measure the radiation emitted from the radioactive particles and a cross section of the part of the body being examined is built up. The procedure is safe, as the amount of radiation involved is tiny.

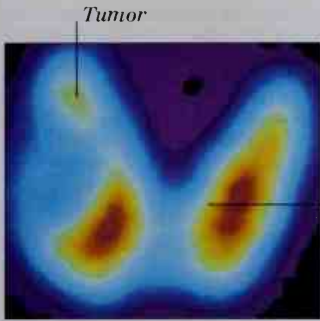

Double-lobed thyroid gland

COLORED GAMMA CAMERA SCAN
When introduced into the body, radio-labeled iodine collects naturally in the thyroid gland. The radiation it emits can be detected by a gamma camera, and the image produced can be used to reveal tumors, as shown above.

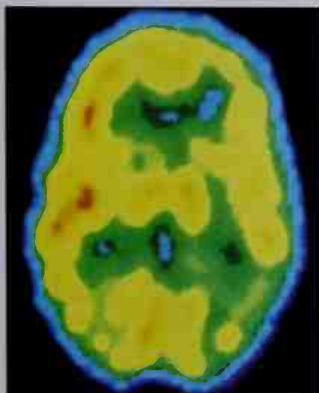
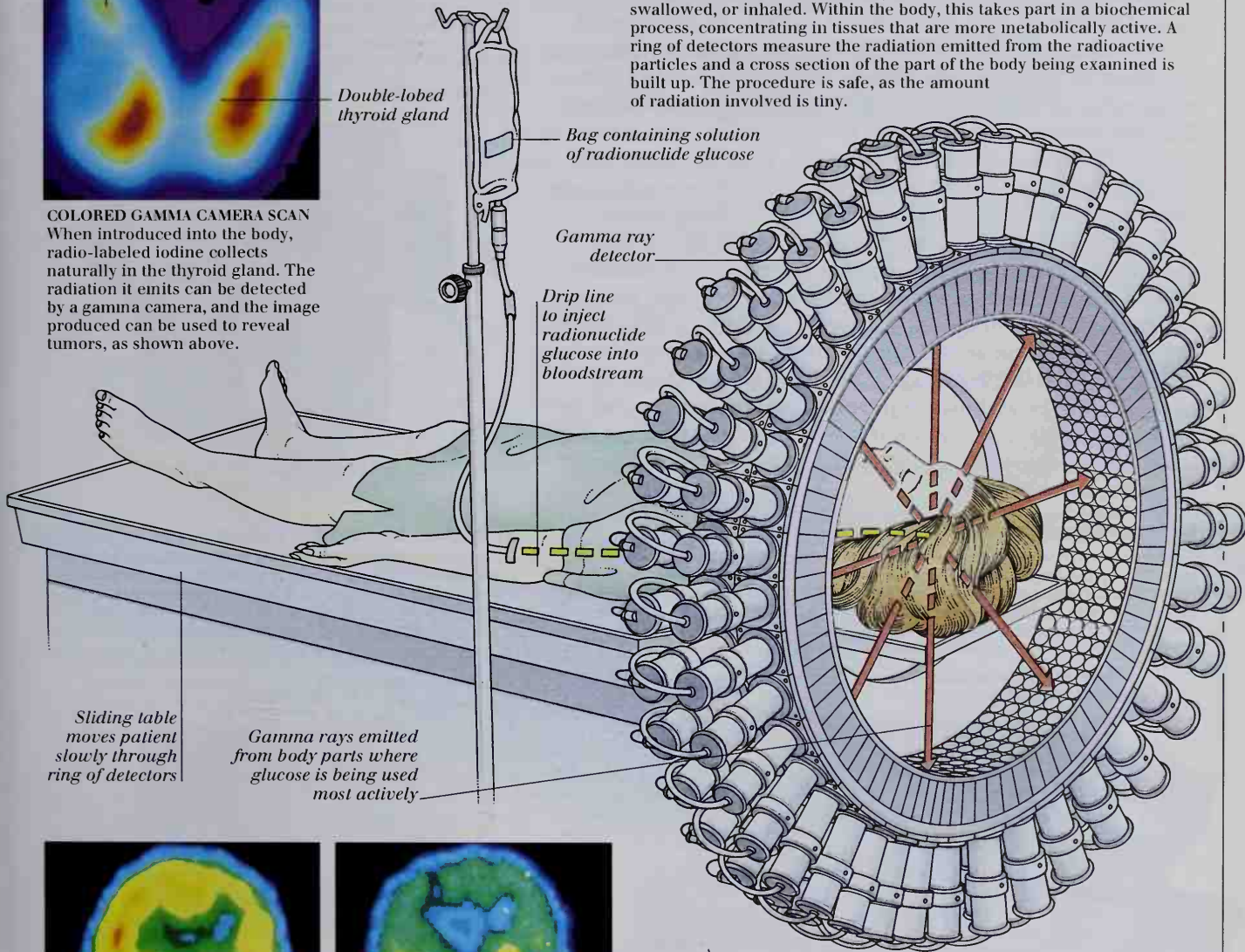

PET SCAN OF A HEALTHY BRAIN
The PET scan above shows the brain of a healthy person after an injection of radioactively labeled glucose. The red and yellow areas show the most active parts of the brain, indicating normal glucose use.

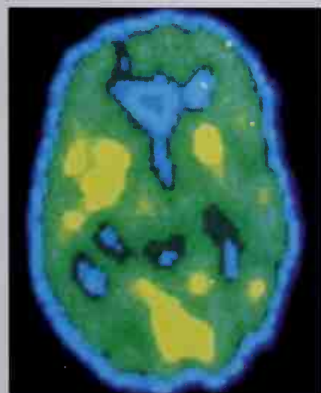

PET SCAN OF A DEPRESSED BRAIN
The large green areas on this PET scan show a low uptake of glucose which indicates a lower level of brain activity. In order to assist interpretation, the computer has colored this scan.

HOW PET SCANNING WORKS

Within the body's tissues, the radioisotopes emit positrons. When a positron collides with an electron, energy is given off in the form of a pair of gamma rays traveling in opposite directions. Detectors, linked to a computer, calculate the point of origin of the rays, and an image can be plotted on a monitor.

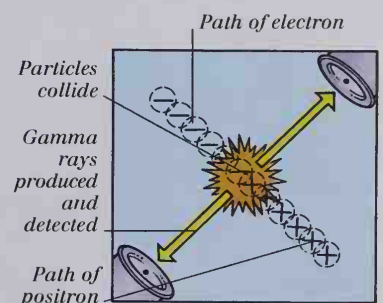

Emergency care

PARAMEDICS AND AMBULANCE STAFF give emergency medical care at the scene of an accident and on route to the hospital. Most accidents are served by ambulances, but **paramedics** now also travel by helicopter and motorcycle. Modern ambulances are equipped to provide basic **first aid** and advanced life support. The aim of ambulance staff is to save the lives of victims and to prevent their condition from worsening. Once on scene, they evaluate the situation and follow the "ABC" of emergency care priorities – Airway, Breathing, and Circulation. Lightweight, portable equipment, such as respirators, defibrillators, and oxygen therapy kits, enable paramedics to treat and stabilize victims without moving them. Injured limbs or joints are immobilized immediately and wounds are dressed to prevent fluid loss and minimize infection. Ambulances also carry a selection of **fast-acting drugs** that can be administered by paramedics. The ambulance provides quick transportation to the hospital emergency room where doctors and medical staff take over and may refer accident victims to other departments including intensive care.

PRIMARY RESPONSE PACK

When paramedics reach the scene of an accident, they often carry a primary response pack. It is light and portable and contains a selection of basic items that are most effective in stabilizing the victim and saving life. The blood pressure monitor and stethoscope can be used to assess the person's condition (see pp. 238-239). The plastic airways and air bag and mask are used to help and, if necessary, assist breathing. Sterile dressings prevent blood loss and minimize the risk of infection.



MONITORING HEART RATE

A heartbeat is essential for circulating oxygen-carrying blood around the body, especially to the brain. The portable heart monitor allows "hands-free" monitoring of the pulse, even if it is very weak. Conductor pads are stuck to the wrist and a screen display and paper trace record the heart's actions. If the heart contracts rapidly and irregularly, "paddles" (not shown) can be attached, which deliver an electric shock to defibrillate the heart into a normal rhythm.



KEEPING THE AIRWAY CLEAR

It is vital that a clear airway (mouth, nose, throat, and windpipe) is maintained so that fresh air can pass into the lungs. The portable aspirator, below, is a battery-powered pump, connected to a long catheter (flexible tube) that sucks out any blood, mucus, or vomit that may be blocking the airway.

BREATHING AND OXYGEN SUPPLY

A shortage of oxygen, due to slow, weak breathing, can be harmful to the brain. When almost pure oxygen is passed into the lungs, the amount being picked up by the blood can be increased. It is supplied by a pressurized cylinder and delivered to the patient via a pressure-reducing regulator, gas tube, and a face mask or plastic airway.



IMMOBILIZING JOINTS

In the event of bone, joint, or nerve damage, the affected part must be immobilized to prevent further injury or even paralysis. If possible, paramedics will do this at the scene of the accident

before transportation to the emergency room. A series of specially designed, lightweight splints and braces have been developed that snap or clip into place around the injured part.



MOVING THE PATIENT

In order to minimize the effect of injuries, the patient should be moved as little as possible. Once lifted onto the hospital cart, they can be wheeled from the scene of the accident to the ambulance then straight into the emergency room. The head end can be raised or lowered for comfort, and the legs can be raised to encourage blood flow to the upper body and brain.



EMERGENCY ROOM

When a patient arrives at the emergency room their injuries are assessed. Some are treated and discharged, others are admitted to other departments in the hospital or for surgery (see pp. 240-245). If needed, a medical cart, below, can be wheeled directly to the victim. It contains essential lifesaving equipment, such as airways, ventilation pumps, and fast-acting drugs.

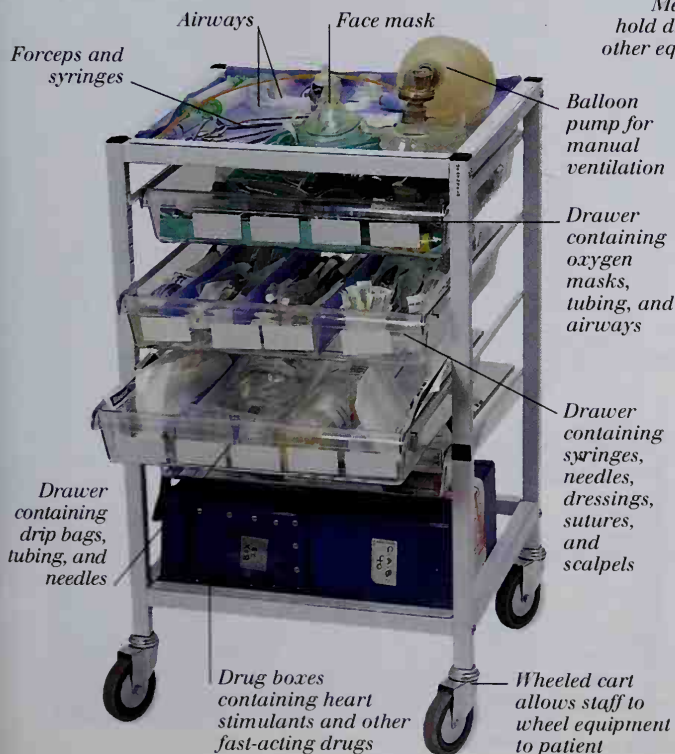

INTENSIVE CARE

Some patients may be so seriously ill that they require intensive care. Units within hospitals that provide this have a huge variety of highly technical equipment. Artificial ventilators, heart defibrillators, and intravenous tubes to deliver drugs and fluids, help keep the patient alive. Sensors and electrodes monitor breathing and heart rates, temperature, and other body variables.



Surgery

SURGERY IS THE MANUAL TREATMENT of diseases, injuries, or deformities. It may be elective – with an element of choice – or non-elective – when it is essential, lifesaving, and usually done in an emergency (see pp. 244-245). Minor surgery, such as the removal of skin warts, can be done, under hygienic conditions, almost anywhere. Major surgery is usually carried out in a specialized room – the operating room – with a team of staff including a chief surgeon and an anesthetist. Surgeons use equipment, such as scalpels and scissors, that has changed little over several centuries. Recent developments in anesthetics and equipment, particularly in the field of less invasive surgery (see pp. 248-249), have enabled surgeons to perform more complicated operations with far less risk to the patient. There have also been huge developments in **transplant surgery** (see pp. 250-251). The heart-lung machine, for example, has made open-heart surgery and heart transplants possible for the first time.

STANDARD SURGICAL INSTRUMENTS

Most basic, handheld surgical instruments have changed little over time. They are specialized to perform physical tasks, such as incising (cutting), probing, gripping, clamping, separating, and suturing (sewing up). The handles are shaped to fit the hand and reduce finger fatigue and sliding. The instruments are generally made of stainless steel or special metal alloys strong enough to deal with tough body tissues and bone and to withstand repeated sterilization with chemicals or steam.

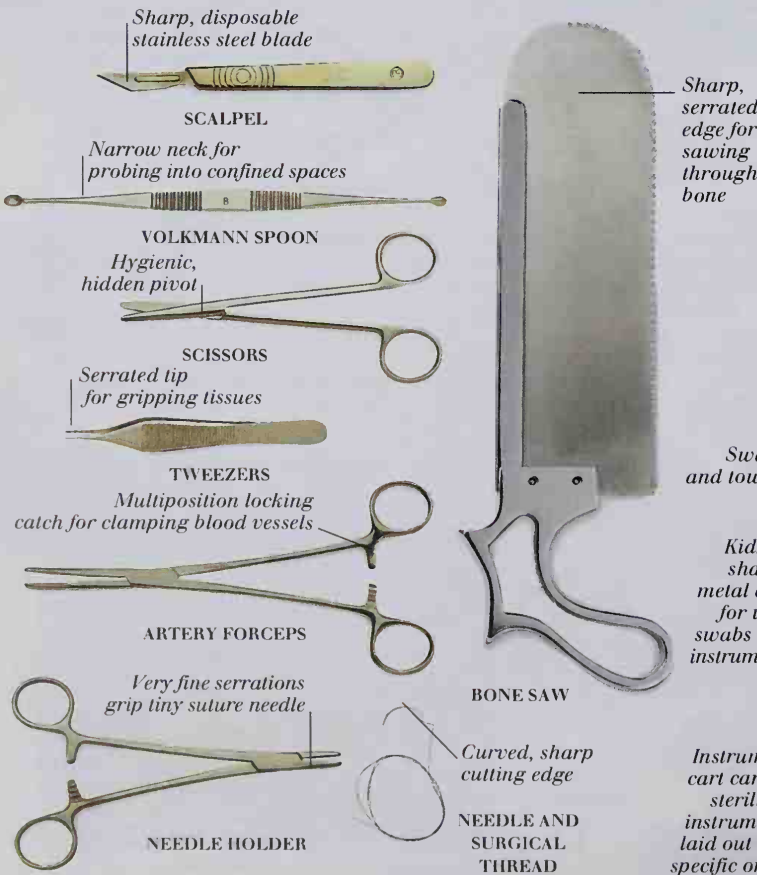

OPERATING ROOM

The operating room is a brightly lit, sterile environment. The air in it is filtered to remove contamination and the walls and floor are washed daily to kill bacteria. Surgeons, nurses, assistants, and the anesthetist all stand in their customary positions, surrounded by surgical and life-support equipment. This increases their efficiency and minimizes the amount that they have to move and look around. They wear sterilized clothing, disposable gloves, and face masks.



HEART-LUNG MACHINE

During open-heart surgery, the heart must be stopped to enable surgeons to work. The cardiopulmonary device (heart-lung machine) takes over the job of circulating blood around the body. A tube connects the heart to the machine, which then cleans, oxygenates, and cools the blood before returning it to the body. Cooling the blood lowers body temperature and allows more time for the operation.

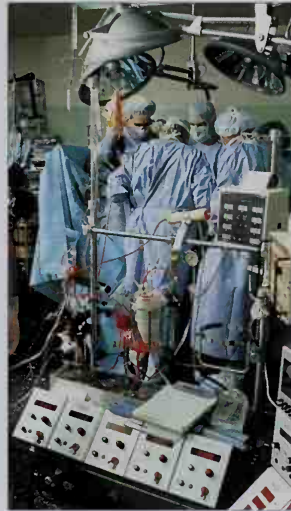

ANESTHETIC

A general anesthetic is usually given during surgery. It is administered as a gas or directly into the blood and has the effect of lowering the activity of the central nervous system, rendering the patient unconscious. A qualified doctor, called an anesthesiologist, administers the anesthetic and monitors the patient throughout the operation. Vital signs such as heartbeat, breathing rate, blood gases, blood pressure, and temperature are monitored electronically and are displayed on screens at the anesthesiologist's station.

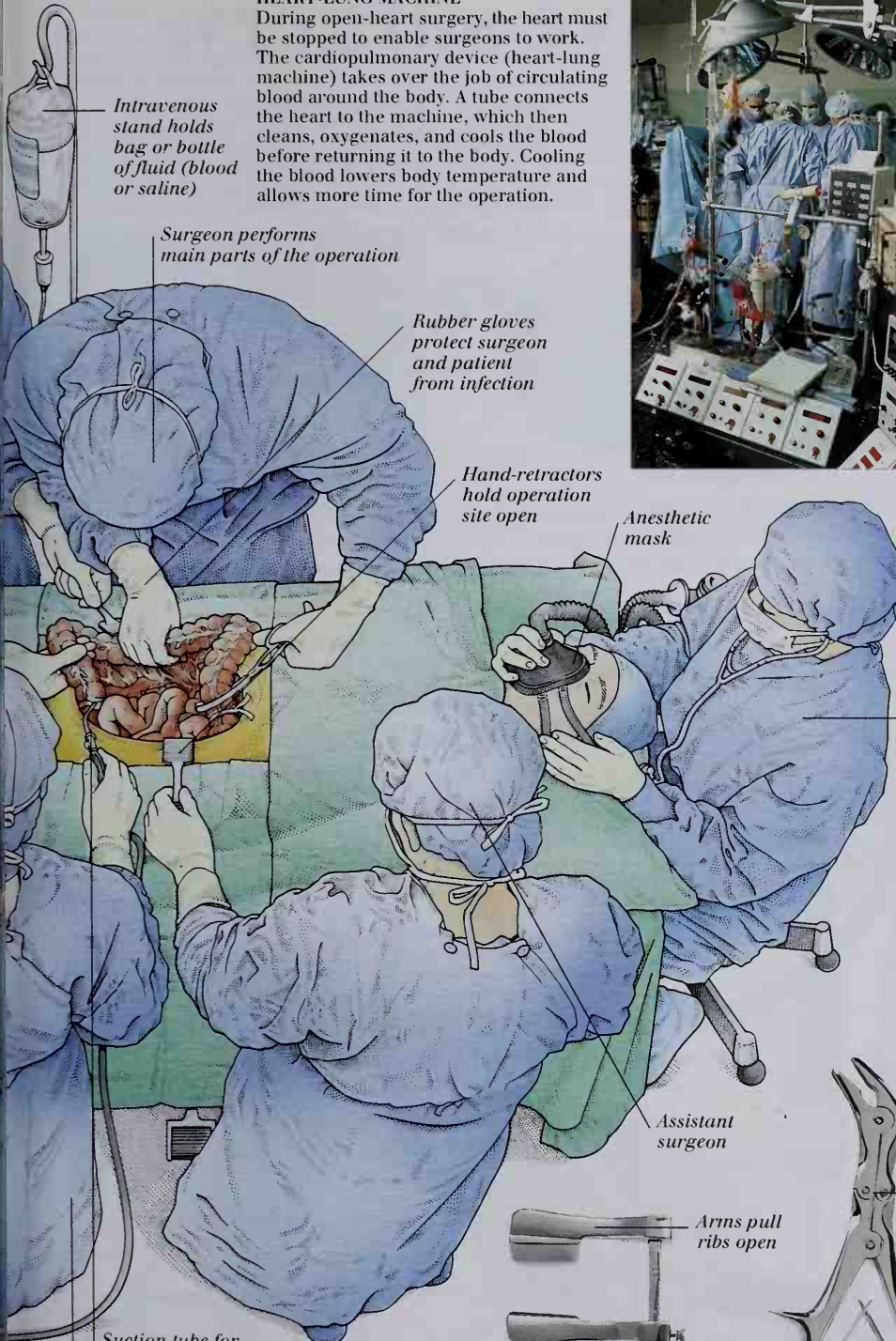
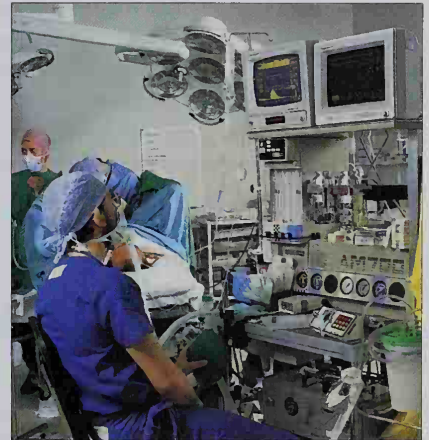

Intravenous stand holds bag or bottle of fluid (blood or saline)

Surgeon performs main parts of the operation

Rubber gloves protect surgeon and patient from infection

Hand-retractors hold operation site open

Anesthetic mask

Anesthetist constantly monitors the patient's vital functions

LUNG RETRACTOR

Retractors act as an extra pair of hands, holding internal organs out of the way so the surgeon can get to the area he or she needs to operate on. Lung retractors press the two lungs apart, allowing access to the heart, which nestles between them.

Whisklike blade pushes soft lung tissue without causing damage

Jaws clamp onto body parts

RONGEUR

The rongeur acts as a powerful clamp cutter on tough body tissue, such as bone, cartilage, and tendons. It can "nibble" away unwanted bone growths or remove prolapsed intervertebral disks (slipped disks) in the back.

Suction tube for removing blood and body fluids

Scrub nurse gives the surgeon the correct instruments

RIB SPREADER

A rib spreader is inserted between two ribs to pull and hold them apart while surgery takes place. They are often used in chest and upper abdomen operations.

Arms pull ribs open

Ratchet mechanism opens up arms

Minimally invasive surgery

TRADITIONAL SURGERY IS “invasive” and “gross.” The body is entered, or invaded, through specially made incisions in the skin and outer layers. Surgeons work at the level of gross anatomy, that is, the scale of size visible to the unaided eye. Recent advances in technology have offered surgeons a different approach involving the least possible physical trauma to the patient. The endoscope has enabled them to view the inside of the body without having to cut it open. It is used for diagnosis and also in keyhole surgery to view and treat internal conditions with minimal disruption to the surrounding tissues. Laser technology uses light as a very precise method of cutting through tissues, destroying unwanted parts and growths, and heat-sealing raw areas. Microsurgical equipment lets the surgeon work at magnifications of up to 50 times, to manipulate and repair tiny and delicate body parts, such as hair-thin nerves and blood vessels. New technology has also helped to train surgeons in a safe way, using virtual reality instead of a live patient.

HOW AN ENDOSCOPE WORKS

Endoscopes consist of a thin plastic tube containing flexible bundles of plastic or glass fibers. A light is shone down one of the bundles to illuminate the area. The image is then reflected back up another bundle. Each fiber shows a tiny area. The whole scene is built up from smaller parts, like dots on a television screen.

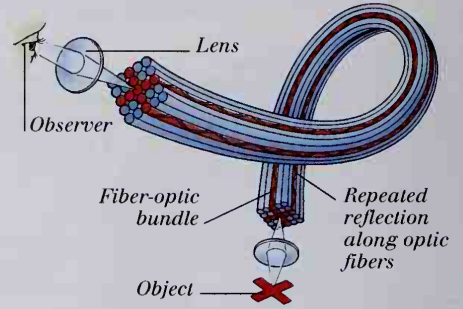

ENDOSCOPY AND KEYHOLE SURGERY

Imaging channel of fiber optics, or electrical wires to a tiny tip camera, show the scene

Markings show how far the endoscope has gone into the body

Coarse optical fiber channel to convey light to tip

Light source attached here

Working channels for instruments

Air or water can be pumped through to “inflate” area for better viewing

Steering mechanism

ENDOSCOPE

An endoscope is used to view the inside of the body without having to perform more invasive surgery. It may be used on its own as a diagnostic tool, with specialized tools to treat a problem, or as an optical aid to keyhole surgery. The flexible tube is inserted into the patient and the doctor views its passage through an eyepiece or on a monitor screen linked to a tiny camera in the endoscopes tip. The tip can be steered and flexed, using guide wires, to obtain a good view.

Eyepiece

Endoscopic attachment Benign ovarian cyst

VIEW THROUGH AN ENDOSCOPE

Endoscopes may be inserted through natural orifices or, in keyhole surgery, through small incisions. The view above shows a benign (non-cancerous) ovarian cyst. This was taken with a laparoscope – an endoscope designed for looking through a small incision in the abdomen.

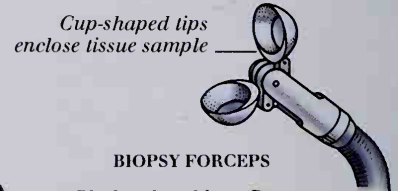

BIOPSY FORCEPS

Blades closed by control wire in endoscope channel

SURGICAL SCISSORS

Bristles rub off cells and fluid for analysis

CYTOLOGY BRUSH

Electric current heats wire to cauterize tissues

CAUTERY LOOP

ENDOSCOPIC ATTACHMENTS

Various devices can be clipped to the endoscope tip or passed along its instrument channel. They can be used to take biopsies (tissue samples) or to perform minor operations, such as polyp removal.

VIRTUAL REALITY SURGERY

Surgery requires great skill and many years of training. Traditionally, trainee surgeons have learned their trade by watching expert surgeons and practicing procedures on real patients. The development of virtual reality has enabled surgeons to practice on simulated situations without risk to a patient. A computer-generated image of the body part, for example the eye, is displayed on a monitor screen and viewed through a binocular microscope. The trainee surgeon manipulates a "scalpel," which is a digitized pen attached to a framework of levers. Its movements are tracked by the computer and displayed with the image. The levers give the scalpel resistance and a realistic feel to its motion.



VIRTUAL REALITY SURGERY IN USE

Stereoscopic operating microscope

Image on monitor screen

Pen represents scalpel

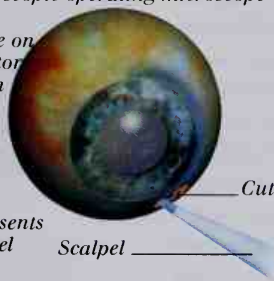

COMPUTER-GENERATED IMAGE OF THE EYE

LASER SURGERY

Laser surgery uses a very thin, high-intensity beam of light (see pp. 56-57) to cut and seal tissues. The light is conveyed from its source along optical fibers to the tip. It can be used with great precision to treat areas of abnormality without damaging the surrounding tissues. If the rays are focused some distance from the tip, they can pass harmlessly through nearer tissues and cut or cauterize further away, at their focus. The heat from the beam of light seals tiny blood vessels and nerve endings during cutting, so there is minimal bleeding and pain from the incision.

Laser light passes along tube to handle



Handle and power controls for single-handed operation

Fiber optic can be retracted while going through hard tissue, such as bone, to avoid damage

Stainless steel shaft contains optical fibers

MICROSURGERY

Electromechanical support arms move microscope and attachments to an accuracy of within one millimeter

Stereoscopic operating microscope magnifies the scene and has auto-focus, auto-zoom, and manual override controls

Control box for zeroing and calibrating the three-dimensional measuring framework and rig arms

Solid base to eliminate movement

Hand control panel (mouth, foot, and personal voice controls are also possible)

Optical track sensor follows movements of microscope and instruments

Floor cable links arm assembly and display console

Monitor screen displays three-dimensional image and measurement coordinates

Computer processes all tracking information and images instantly, in real time, creating "live" image updates

STEREOTACTIC MICROSURGICAL RIG

Microsurgery allows surgeons to operate on parts of the body that were previously inaccessible or too small to work on, such as the inside of the ear, the spinal cord, and the brain. Highly intricate procedures are performed using miniature precision instruments and viewed under an operating microscope. The stereotactic rig provides a framework for

measuring and controlling the instruments. Using delicate, mechanical sensors in the support arm and optical-beam sensors on the operating microscope, the instruments and the area being treated are tracked and calculated to an accuracy of within one millimeter. All the information is fed into a computer, which displays the scene on a monitor screen and controls the rig's movements.

Transplants

TRANSPLANTATION IS THE IMPLANTATION of organs or the grafting of tissues from one person to another or from one part of the same body to another. Biological tissues and organs can be donated by human beings or derived from animals (see pp. 262-263). Success depends on compatibility between the donor and recipient, autografts (self-grafts) being the most successful. Transplants have become possible because of major developments in the science of immunology, and in the pharmacology of drugs capable of suppressing immunological reactions without causing too much danger to the patient. The success of transplantation has also required substantial developments in surgical technique and in ways of avoiding infection during surgery (see pp. 246-247). Initially, success in transplantation was limited to corneal and kidney grafts. Today, almost any organ in the body, outside the nervous system, can be successfully transplanted, as can many tissues.

T CELL

Lymphocytes are types of white blood cells that are involved in the immune system. There are two types, B cells and T cells. B cells are responsible for producing antibodies (see Transplant and Graft Rejection below), and T cells (shown here) act as recognition agents, B-cell helpers, and killers of certain cell invaders. T cells can recognize and kill cancer cells, cells infected with viruses, and cells from a different individual, for example in a transplanted organ.



TRANSPLANT AND GRAFT REJECTION

All biological tissues carry chemical "flags," called antigens, which can be identified by the immune system. In most cases, except with identical twins, donated organs or tissue are immediately recognized as "foreign." This promotes a destructive reaction by T cells and the production of antibodies by B cells (see below). These reactions occur at the interface between the grafted organ and the host. Drugs such as cyclosporin have been developed to suppress the immune system and to help prevent rejection of transplanted organs and grafts.

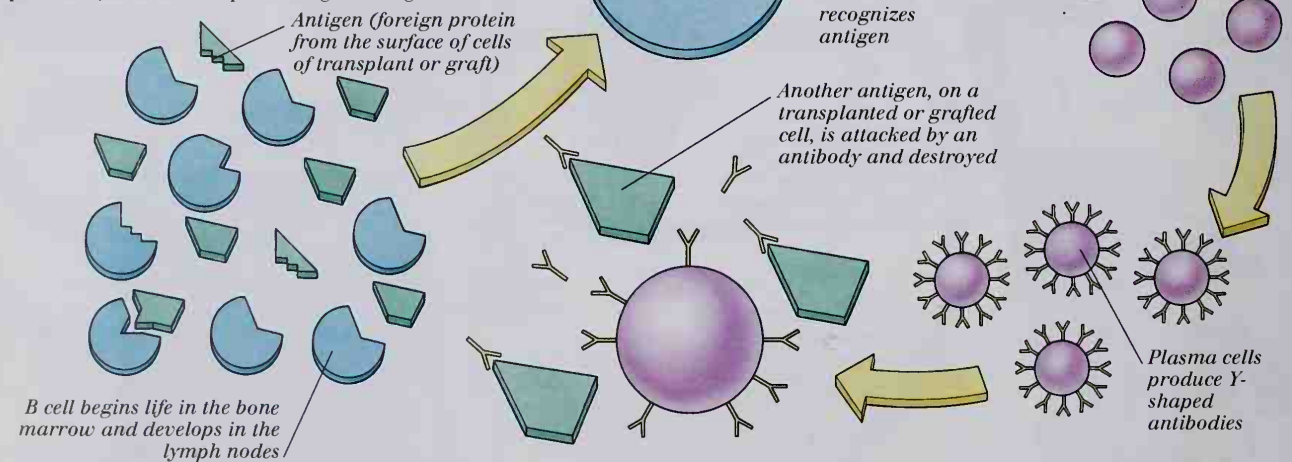

BONE MARROW

Bone marrow is a bloodlike liquid containing stem cells – the cells from which the red and white blood cells are developed. When transplanted, these enable the recipient to make new, healthy blood cells. The bone marrow is usually taken from a pelvic bone (iliac crest) or from the breastbone (sternum). It is removed, under local or general anesthetic, by passing a strong needle through the outer plate of the bone and drawing the marrow into a syringe.



EXAMPLES OF TRANSPLANTS

Any organ in the chest or abdomen can now be successfully transplanted. In the case of the eye, only the cornea is used, as removing the whole eye would involve cutting the optic nerve, which cannot be rejoined. Skin and bone can be transplanted only from one site to another on the same person; this is called an autograft. Many transplanted organs, such as the heart and lungs, must be inserted into the same site as the original organs. In some instances it is safer and surgically more convenient to place the organ in a different site; a transplanted kidney, for example, is always placed in the pelvis near the bladder.

Transplanted cornea can restore sight

Fetal tissue can be transplanted into the brain

Heart and lungs are often transplanted together

Lungs

Heart

Liver

Pancreas - the whole organ or pancreatic islets can be transplanted

Bone marrow

Blood

Kidney - one or both kidneys can be replaced

Sections of intestine can be used to replace diseased areas

Skin grafts are only possible as autografts

Bone - sections of bone can be cut out and transplanted to areas that are weak or need additional reinforcement

Fascia - this thin sheet of dense, fibrous tissue lies over the muscle and beneath the skin and can be used to reinforce hernias

TISSUE TRANSPLANTS

BLOOD TRANSFUSION

Blood is the most common tissue to be transplanted. It is obtained by bleeding volunteer donors from a vein into a sterile receptacle containing a chemical that prevents the blood from clotting. About 450 ml of blood is taken. As a dangerous reaction occurs if blood of the wrong group is transfused, a test, called cross-matching, is performed. This involves mixing donor red cells with serum from the recipient. Incompatibility is shown by agglutination (clumping) of the donor red cells.



Label shows date blood was taken and gives donor information, including blood group

Sterile plastic bag contains blood

Pig-tissue valve



HEART-VALVE TRANSPLANT

Heart valves can be replaced by a bionic, mechanical valve (see pp. 252-253) or a biological valve from a human or pig donor. Pig valves are sometimes used since they are readily available, very similar to human valves, and do not cause blood clots as mechanical valves do. Unfortunately, they only have a working life of 7 to 10 years before the tissues degenerate.

KIDNEY DIALYSIS

A lack of donor organs for transplantation often means that people with total kidney failure have to wait long periods before a suitable kidney becomes available. During this time a technique called hemodialysis takes over the function of the diseased kidney. The dialysis machine consists of a system of tubes or plates made of a semiporous material and immersed in a watery solution. Blood is pumped from the patient, into the system where impurities diffuse out into the water, which is continuously renewed. The procedure is fairly simple and requires three 4-8 hour sessions a week.

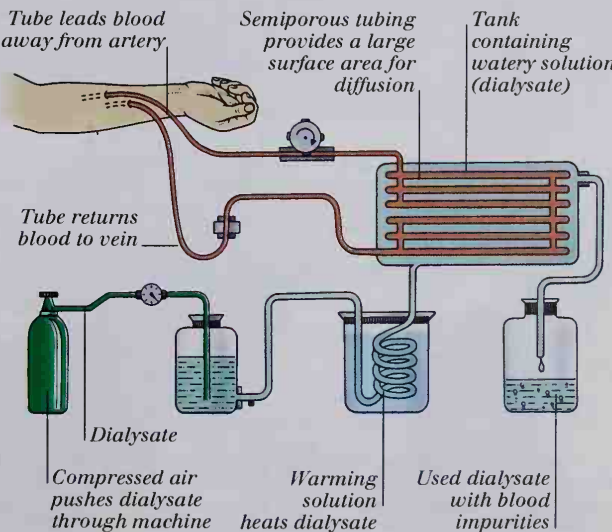

Artificial body parts

THE DEVELOPMENT OF BIOENGINEERING – a discipline involving close cooperation between doctors and mechanical and electronic engineers – and advances in technology and materials science have brought about a medical revolution in the area of artificial body parts. Bionic structures have been developed, and implanted artificial body parts, such as heart pacemakers, are now used extensively. Safe implantation involves the use of materials that do not excite adverse **chemical reactions** in the **tissues**. Some metals, such as iron and copper, are dangerous when implanted into the body. Therefore alloys that remain **inert** when in contact with tissue fluids are used. Many synthetic, polymer, plastic materials have proved to be safe, and some, such as silicone rubber, even allow the **diffusion** of oxygen. In most cases, the development of the ideal design of an implantable part has involved years of trial. Modern implants are consequently very successful and reliable.

HEART PACEMAKER

When a heart cannot respond normally to the demands made on it, an artificial pacemaker may be implanted. This electronic device sends a series of small electric pulses to the heart, causing it to

beat regularly. Demand pacemakers work more quickly when required and can be programmed from the outside by radio signals. Pacemakers work by internal batteries that last for about 10 years.

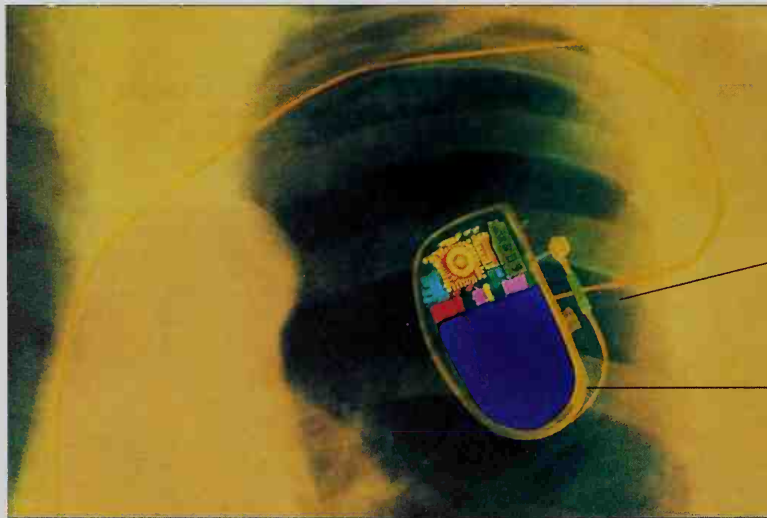

Lead connects pacemaker to heart

Electronic heart pacemaker fitted in the chest

MECHANICAL HEART VALVES

Several types of heart disease can lead to severe narrowing or leakage of the heart valves. As a result, the heart has to work more strenuously and may eventually fail. Heart valves can be replaced with

biological valves (see pp. 250-251) or one of a range of reliable, mechanical valves. These are very efficient and present no rejection problems, but require long-term blood anticoagulating treatment.

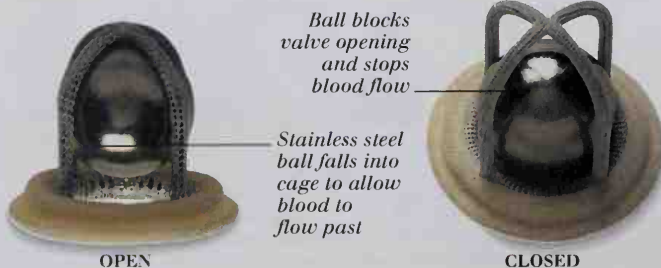

Ball blocks valve opening and stops blood flow

Stainless steel ball falls into cage to allow blood to flow past

OPEN

CLOSED

ARTIFICIAL EYE LENS

An artificial lens may be implanted in order to refocus the eye after the removal of a cataract. The optical power of the lens is set using **ultrasound** measurements taken before the operation. The lens is centered and held within the transparent capsule of the original lens by supporting loops.

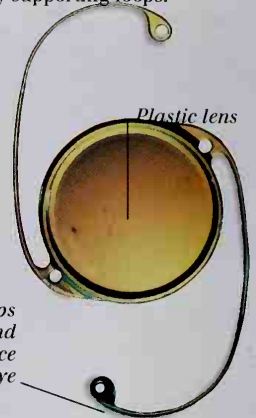

Delicate loops center lens and hold it in place within the eye

VASCULAR GRAFTS

At the end of the 20th century, the most common cause of long-term illness and premature death has been the formation of **cholesterol plaques** in the arteries. This may cause a blockage or weaken the artery, causing its wall to bulge or split. Replacement of the diseased area with a woven-plastic arterial graft can be lifesaving. Before being sewn in place, the inert material is soaked in blood. Body cells, called **fibroblasts**, then invade the structure and eventually turn it into virtually normal body tissue.

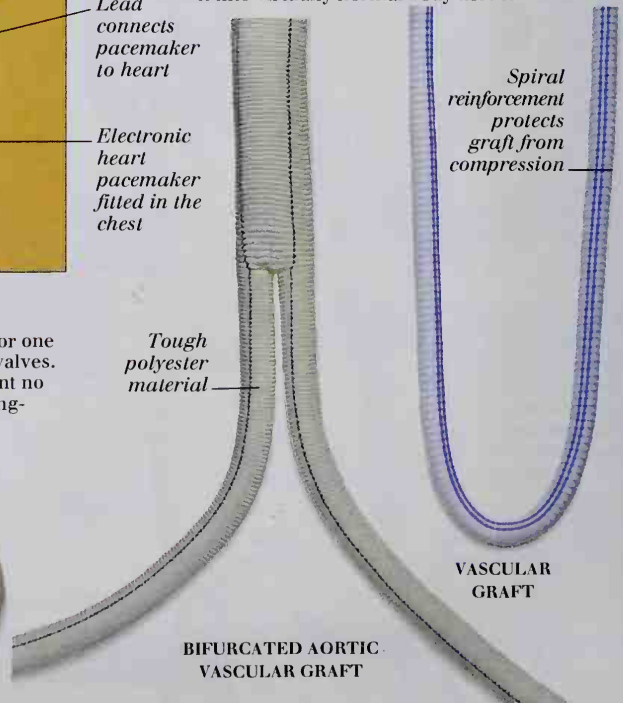

Tough polyester material

Spiral reinforcement protects graft from compression

BIFURCATED AORTIC VASCULAR GRAFT

VASCULAR GRAFT

EXAMPLES OF ARTIFICIAL PARTS

Artificial body attachments, such as false teeth and hooks to replace lost hands, have been used for hundreds of years and predate any implanted body parts. The problem of causing a rejection reaction by the body's immune system (see pp. 250-251) has, until quite recently, prevented the implantation of such artificial body parts as pacemakers and joints. Inert materials, such as metal alloys and plastics, do not react chemically with body fluids and are strong enough to withstand repeated use. Their development has made implantation possible.

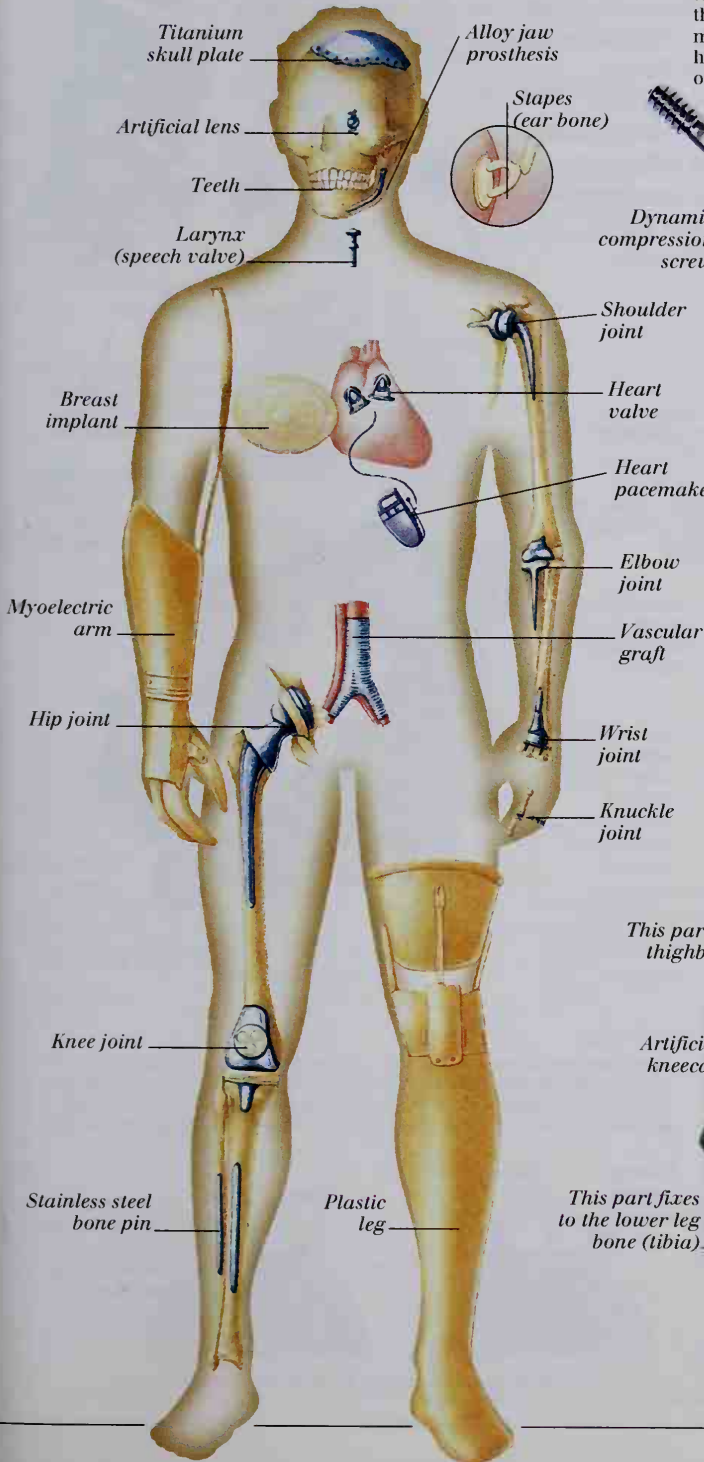

ARTIFICIAL ORTHOPEDIC PARTS

MYOELECTRIC ARM

Even after the total loss of a wrist and hand, the muscles in the forearm can still contract in an attempt to move the missing limb. Modern transducer technology has made it possible to sensitively detect these movements. Amplified control signals are sent to its motors and other activators to bring about the desired actions in the artificial arm. The availability of microprocessors on a single silicon chip has helped greatly in the development of these devices.

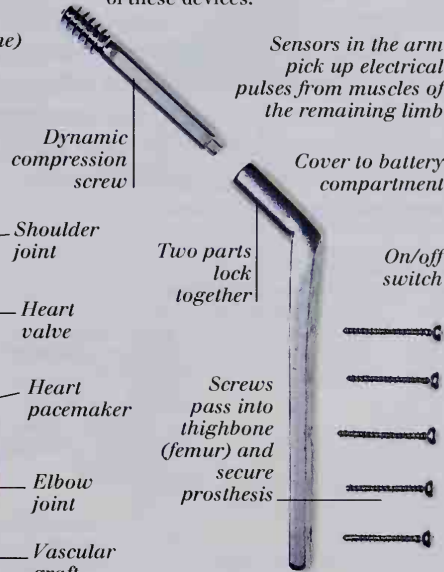

DYNAMIC HIP SCREW

Fracture of the neck of the thigh bone (femur) is a common injury in elderly people. It can be stabilized using a dynamic hip screw. The upper part is screwed inside the fractured neck, while the lower part is fixed into the shaft of the femur.

This part fixes to the thighbone (femur)

Artificial kneecap

This part fixes to the lower leg bone (tibia)



KNEE-JOINT PROSTHESIS

Knee movements are complex and involve sliding and slight rotation. These elements are incorporated into the design of modern artificial knee joints, making them highly effective prostheses.

Sensors in the arm pick up electrical pulses from muscles of the remaining limb

Cover to battery compartment

On/off switch



Wrist twist

Electronic control unit

Servo (powerful electric motor)

Moving thumb

Two fingers move toward thumb to give a powerful grip



Drugs and drug delivery

A DRUG IS ANY SUBSTANCE that can affect the structure or functioning of the body. Drugs are used to prevent, **diagnose**, and treat **disease** and to relieve **symptoms**. Drug action ranges enormously; they may be used to save life in cases of dangerous infection or they may be used to relieve minor skin irritations. Pharmacology – the science of drugs and how they work – has developed into a highly sophisticated discipline. Drug action is now well understood and new drugs are designed by computer. Advances have also occurred in the pharmaceutical industry, which applies the technology that is based on pharmacology. Drugs may be administered in many different ways: including by ingestion, inhalation, injection, skin implantation, skin application, or insertion. All the drugs given in these ways require special formulation in order to ensure correct dosage, reasonable shelf life, and maximum safety.

NATURAL DRUGS

The earliest effective medical substances were largely of natural origin and derived from plants. This was the case until well into the 20th century. Such drugs included quinine, opium, cocaine, and digitalis.



Digitalis tablet



FOXGLOVE
(*Digitalis purpurea*)

COMPOSITION OF A TABLET

Some drugs may be formulated as a tablet. The design of a tablet involves determining the best inert substances with which to mix the active ingredient. Inert materials include binding agents, lubricants, disintegrating agents,

lubricants, disintegrating agents, dispersing agents, preservatives, and flavorings. Often, the weight of the active substance is only a tiny proportion of the total weight of the tablet.

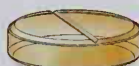
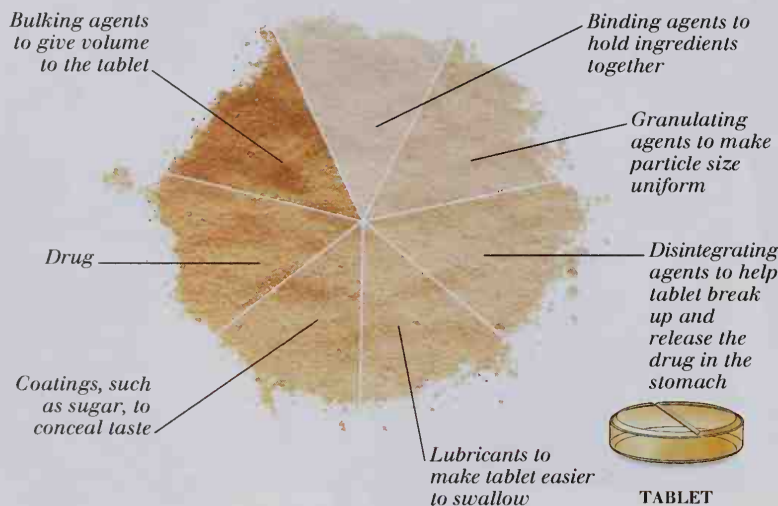

TABLET

DRUG DEVELOPMENT

Modern methods of drug development often involve the use of computers to aid in the synthesis of new compounds by the modification of molecules of known pharmacological action. This is followed by extensive trials to establish the drug's effectiveness and safety.

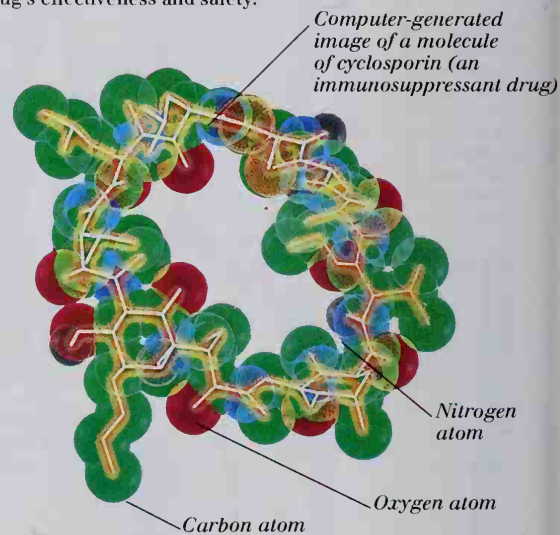

HOW DRUGS WORK

All cells have receptor sites on the outer surface of the cell membrane. Drugs are shaped to lock into these receptor sites and, as a result, effect changes within the cell. Using this method, drugs can work in two ways: they can resemble a natural body substance that normally

stimulates the receptors; or they can block the receptor sites so that the natural substances cannot have their normal effect. Drugs can be designed to produce a more powerful stimulus to the cell than natural substances. They can also block the receptors for prolonged periods.

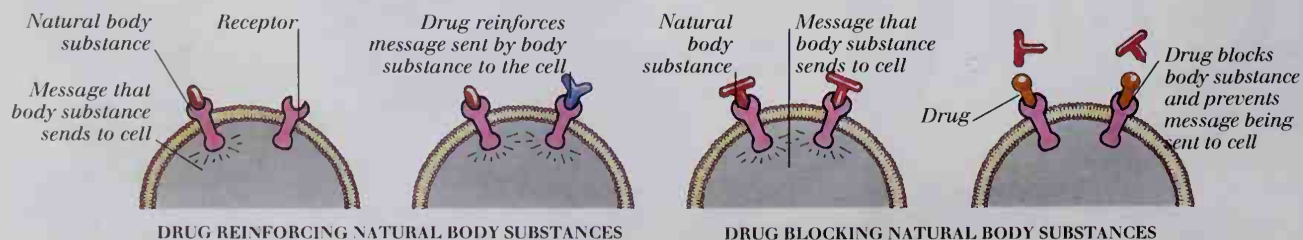

DRUG REINFORCING NATURAL BODY SUBSTANCES

DRUG BLOCKING NATURAL BODY SUBSTANCES

SITES AND ROUTES OF DRUG ADMINISTRATION

There are a huge number of ways in which drugs can be introduced into the body. All of the body's orifices can be used, either for local application or to allow the drug to be absorbed into the bloodstream for general distribution around the body. Drugs that are required to act quickly are given by intravenous injection; drugs given by subcutaneous or intramuscular injections are absorbed at varying rates, depending on the medium in which they are dissolved or suspended. The slowest absorption and longest action is provided by depot implants and skin patches.

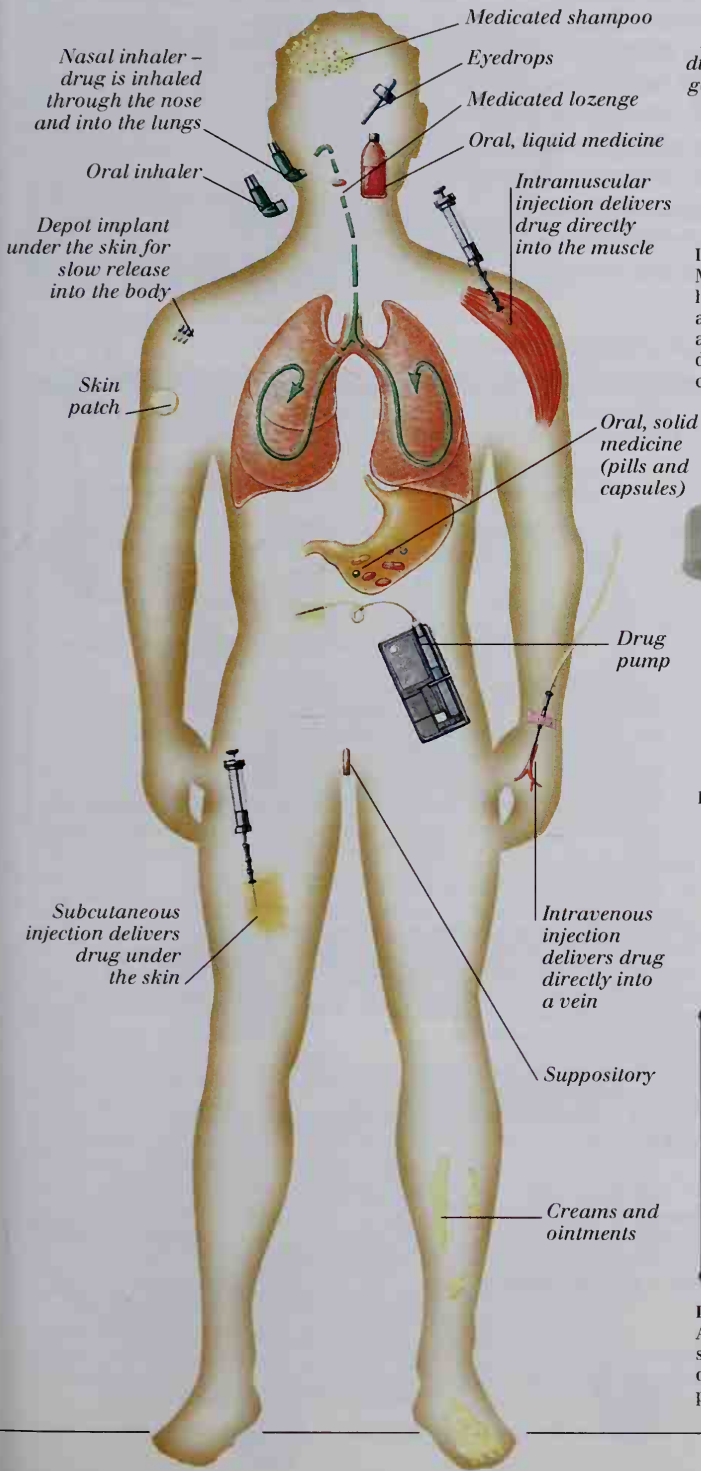

METHODS OF DRUG ADMINISTRATION



ORAL INHALER
INHALED MEDICINE
 Medication for certain lung disorders, chiefly asthma, is delivered by an aerosol or in a dispersed powder cloud from an inhaler.

TABLETS AND CAPSULES
ORAL MEDICINE
 The majority of drugs are taken by mouth, most commonly in the form of tablets or capsules. The practice of giving drugs in the form of liquids, once the commonest vehicle, is now rare, as accurate dosage is impossible.

ELIXIR



DROPPER
EYE- AND EARDROPS
 Some drugs can be applied in a higher dosage when formulated as eye- or eardrops. They are absorbed directly by the affected structure.



CREAM
SKIN PATCH
 Patch is stuck to skin and slowly releases drug



DRUG PUMP
 A mechanical drug pump can be set to deliver drugs in an exact dosage, either continuously or at precise intervals.

SKIN PATCH
TOPICAL SKIN PREPARATIONS
 Local application to a body surface is called topical, and refers mostly to the skin. Topical preparations may be lotions, creams, ointments, or skin patches. Topical drugs include antibiotics, antifungals, hormones, and protective substances. Some topical drugs are formulated to be absorbed into the skin; others have an action confined to the surface skin layers.

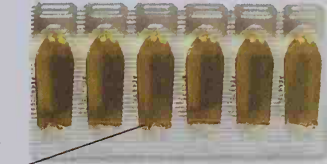

SUPPOSITORIES
 Suppositories can be inserted into the vagina or rectum. The drug is delivered topically and it is absorbed into mucous membranes.

Pregnancy and childbirth

THE PERIOD FROM THE FERTILIZATION OF AN EGG to the birth of a young human being is known as pregnancy and takes about nine months (38 weeks). In recent decades, medical science has become involved in many stages of pregnancy and childbirth. Fertility treatments, including *in vitro* fertilization, have been developed to help people with low fertility levels. Once pregnancy has been confirmed, screening tests such as blood tests, chorionic villus sampling, and amniocentesis are done to check general health and test for any genetic or chromosomal abnormalities (see pp. 262-263). During labor and the delivery, monitoring equipment is used to measure contractions and the baby's heartbeat. If the birth is difficult, doctors may assist by performing a cesarian section, by using forceps, or by using vacuum extraction. Babies that are born ill or premature (early) are cared for in special baby care units, often in incubators, until they recover health and strength.

PREGNANCY TESTS

Most pregnancy tests check for the presence of **human chorionic gonadotropin (hCG)**, which can be detected in urine or blood. Home tests (see below) use chemicals, on a card or dipstick, to test for hCG in the urine 14 days after the mother's first missed menstrual period.

Chemicals detect hCG in urine
Change in color indicates positive pregnancy result



HOW IN VITRO FERTILIZATION (IVF) WORKS

IVF is often used in cases of infertility to increase the chances of conception. *In vitro* literally means "in glass"; children conceived this way are sometimes known as "test-tube babies." Fertility drugs are taken to stimulate eggs to mature in the woman's ovaries. They

are collected with a long aspiration needle, using an ultrasound image as a guide. The ripe eggs are mixed with sperm in an incubated culture dish. The cells then divide, and at around the eight-cell stage, two or three embryos are transferred into the uterus using a catheter.

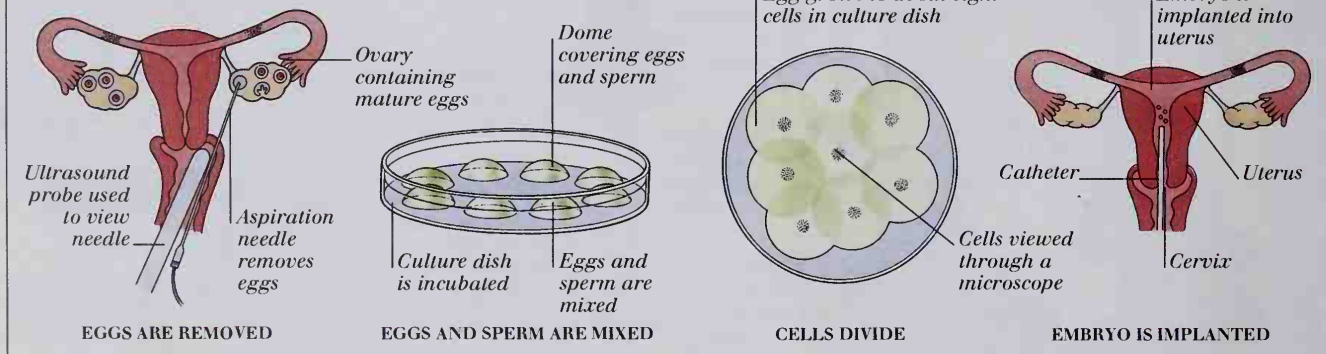

AIDING FERTILIZATION

The process of IVF (and other, similar infertility treatments) involves the chance meeting of an egg and a sperm in a petri dish. To increase the chances of fertilization, a technique has been developed whereby the male genetic material is injected directly into the female egg. The ripe egg is held steady on the end of a micropipette, and a very fine needle is used to inject the sperm cell into it. This all takes place under a high-powered microscope.

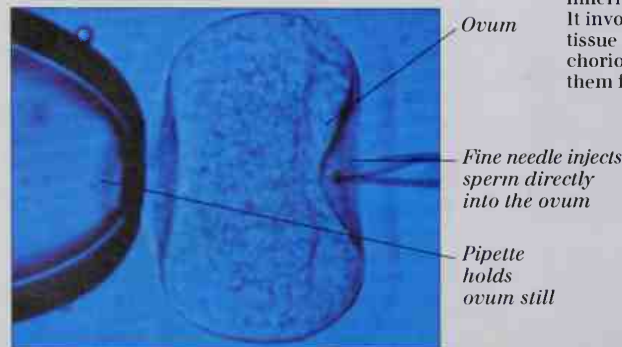

PRENATAL TESTS

Prenatal tests are done before the baby is born and are designed to assess the well-being of the mother and of the developing baby. Some tests are routine, such as urine and blood tests. Others, such as amniocentesis and fetal blood sampling, are performed only if the baby is considered to be at risk. Chorionic villus sampling, seen here, is used when problems such as chromosome abnormalities or inherited disorders are suspected. It involves taking blood and tissue samples from the chorionic villi and sending them for laboratory tests.

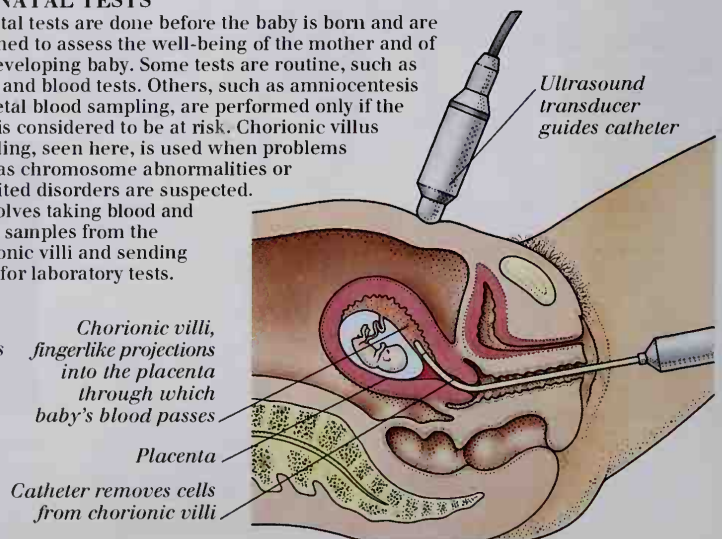

MONITORING THE BABY DURING LABOR

Labor is the first main stage of childbirth, when the strong uterine muscles begin to contract. It can be stressful for the baby, and electronic fetal monitoring (EFM) is sometimes used. Internal fetal monitoring involves clipping a small electrode to the baby's skin, usually the scalp. This detects the electrical signals of the baby's heartbeat, which are displayed on a monitor screen or paper strip. A catheter, inserted through the birth canal into the uterus, detects the pressure inside. If the baby's heart rate drops or the intrauterine pressure gets too high, doctors may need to intervene.

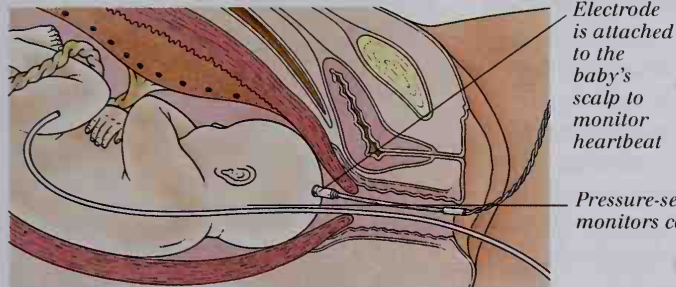

Electrode is attached to the baby's scalp to monitor heartbeat

Pressure-sensitive catheter monitors contractions

ASSISTED DELIVERY

In some instances it may be necessary for the doctor to assist with the delivery. If the baby's head is in the correct position, vacuum extraction or forceps may be used. Vacuum extraction uses a disk-shaped plastic cup, which is applied to the baby's head, and a vacuum pump. When the pump is turned on, the suction created enables the doctor to pull the baby into view. Forceps have become less commonly used. The two blades are clipped around the head and the doctor uses the handles to guide the baby's head out through the birth canal. The forceps can then be removed and the baby delivered normally.

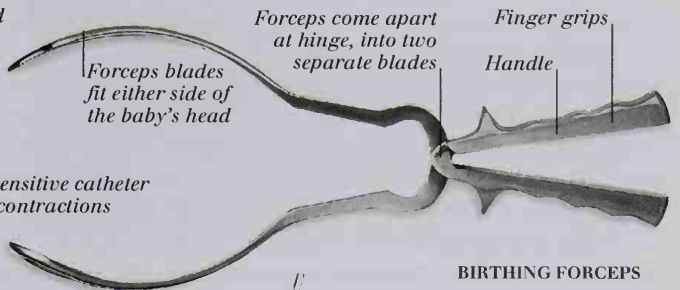

Forceps blades fit either side of the baby's head

Forceps come apart at hinge, into two separate blades

Finger grips

Handle

BIRTHING FORCEPS

SPECIAL BABY CARE

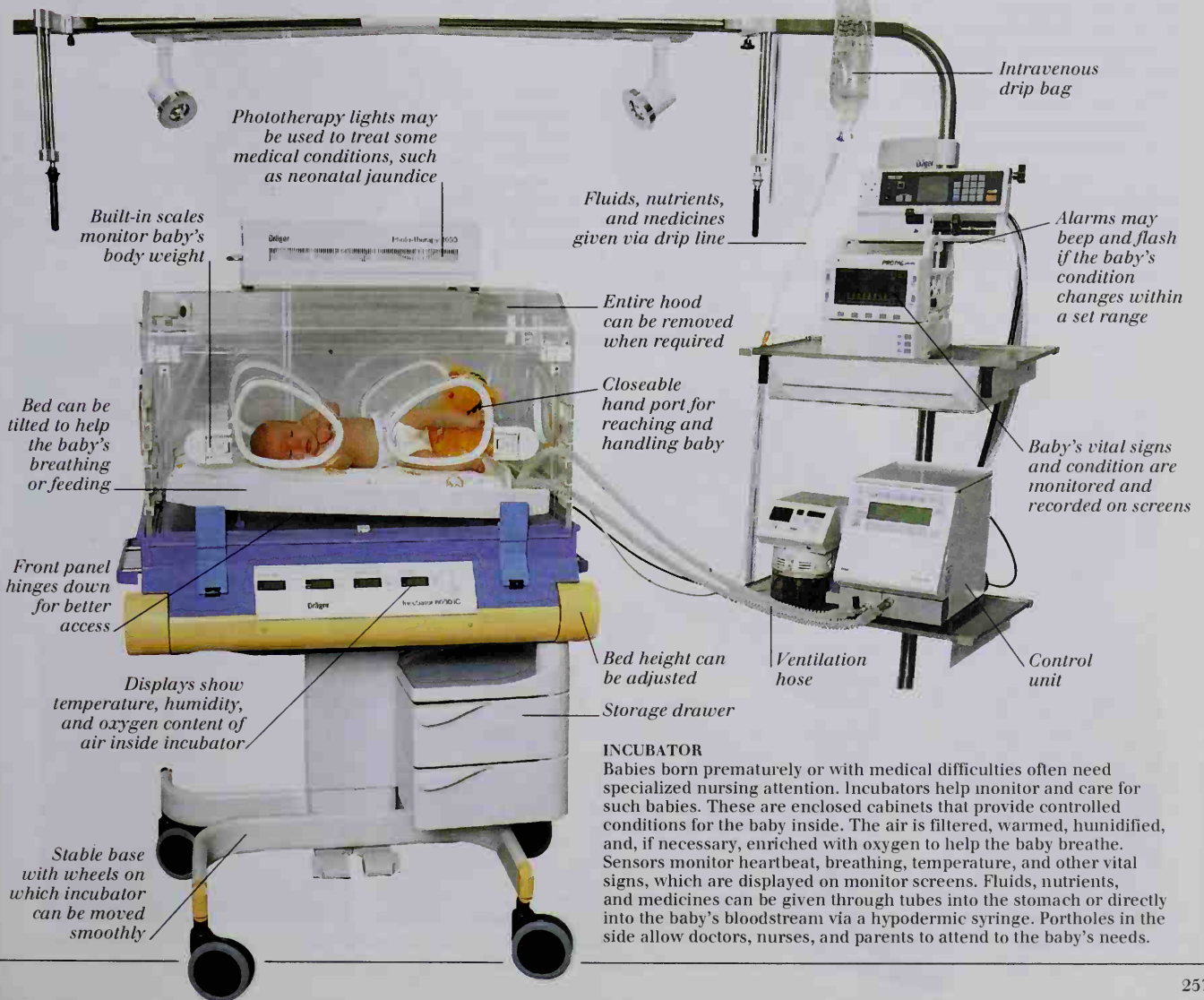

Phototherapy lights may be used to treat some medical conditions, such as neonatal jaundice

Built-in scales monitor baby's body weight

Fluids, nutrients, and medicines given via drip line

Intravenous drip bag

Alarms may beep and flash if the baby's condition changes within a set range

Entire hood can be removed when required

Closeable hand port for reaching and handling baby

Baby's vital signs and condition are monitored and recorded on screens

Bed can be tilted to help the baby's breathing or feeding

Front panel hinges down for better access

Displays show temperature, humidity, and oxygen content of air inside incubator

Bed height can be adjusted

Storage drawer

Ventilation hose

Control unit

Stable base with wheels on which incubator can be moved smoothly

INCUBATOR

Babies born prematurely or with medical difficulties often need specialized nursing attention. Incubators help monitor and care for such babies. These are enclosed cabinets that provide controlled conditions for the baby inside. The air is filtered, warmed, humidified, and, if necessary, enriched with oxygen to help the baby breathe. Sensors monitor heartbeat, breathing, temperature, and other vital signs, which are displayed on monitor screens. Fluids, nutrients, and medicines can be given through tubes into the stomach or directly into the baby's bloodstream via a hypodermic syringe. Portholes in the side allow doctors, nurses, and parents to attend to the baby's needs.

Infection and disease

INFECTION IS THE INVASION of the body by germs (microorganisms) that can cause disease. The term is also used to describe the actual disease caused by germs, a disease being a disorder, not resulting from physical injury, with a specific cause and recognizable **symptoms**. As a result of improved standards of hygiene and more effective **antibiotics** and drugs, infections are no longer the principal cause of disease in developed countries. However, they still cause much damage to the quality of life and result in many deaths. A wide range of infecting microorganisms can cause disease. These include viruses, bacteria, fungi, protozoa, and microscopic worms. Recently, a new addition to the list – the prion protein – has attracted much interest and considerable scientific research. Also of great concern are the **evolutionary** changes in many microorganisms, especially viruses and bacteria, that lead to their becoming **resistant** to previously effective antibiotics.

CULTURE PLATES

These dishes contain a medium, often **agar**, on which bacteria and other microorganisms will grow. They are incubated at human body temperature (37 °C). Bacterial culture is as an essential part of medical diagnosis (see pp. 238-239). Antibiotic sensitivity can be tested by placing disks of paper soaked in antibiotic solutions onto the culture plate. The largest zone of growth inhibition indicates which antibiotic will be the most effective in treating the infection.



Merged growths, or colonies, of bacteria

Colonies dripped by pipette containing antibiotics

Colonies grow in strands where smeared by spreader

GROWING A CULTURE



Healthy growth of yeast microbes

Paper disk containing anti-fungal drug

Area where drug has spread into agar and prevented yeast growth

ANTIBIOTIC SENSITIVITY



BIOCHEMICAL RESEARCH

An important part of the war against infection is the development of new and more effective antibiotics and other drugs. Biochemical research can work out their chemical structure and change them by informed modification.

VIRAL INFECTIONS

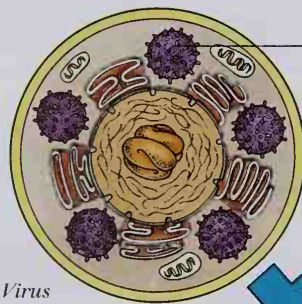
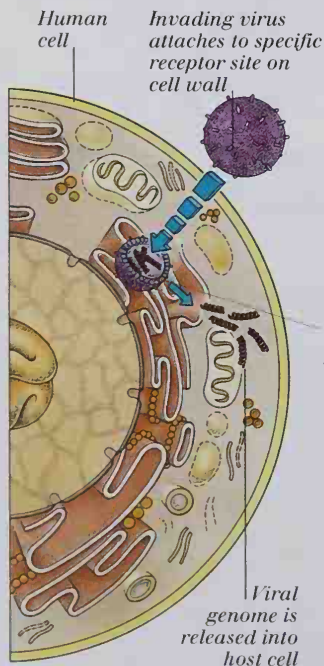

HOW A VIRAL INFECTION OCCURS

Viruses can reproduce only inside living cells. The outer surface of a cell is studded with receptor sites to which viruses attach themselves in order to enter the cell. The virus sheds its protein coat to expose the viral **genome** – DNA or RNA – which incorporates itself into the genome of the cell. This allows the virus to reproduce many times, until the host cell bursts and releases them.

Host cell swells with virus particles and eventually bursts

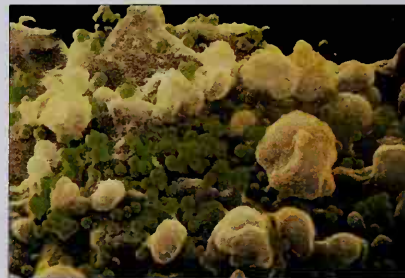
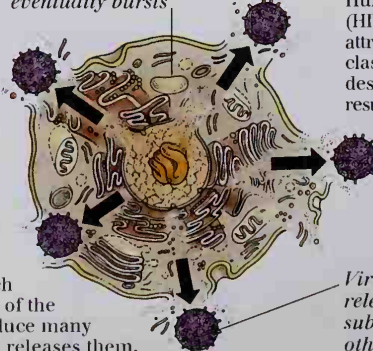

HIV Human Immunodeficiency Virus (HIV) is a **retrovirus** with a specific attraction to cells of the helper class of T lymphocytes. It is the destruction of these cells that results in the severe damage to the function of the immune system – the Acquired Immune Deficiency Syndrome (AIDS).

PROTOZOAN INFECTIONS

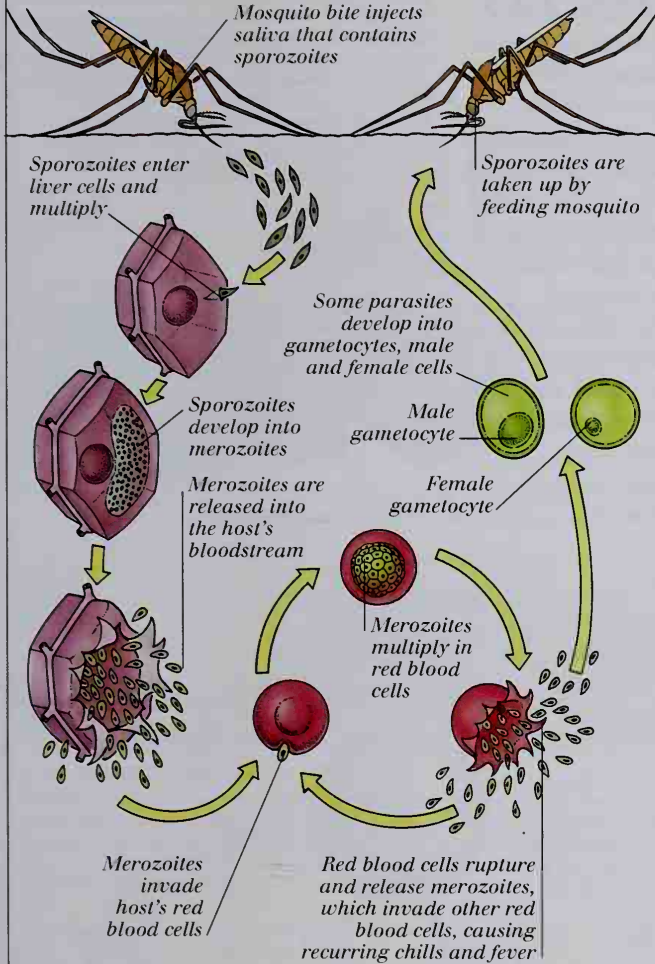

HOW MALARIA OCCURS

Malaria is caused by a protozoan spread by certain mosquitoes. While feeding on a malaria sufferer, they take up blood containing malarial parasites. These multiply in the mosquito and enter its salivary glands. When it next feeds, it injects the parasites into the bloodstream of another human being. The parasites pass to the liver, where they multiply before re-entering the bloodstream and invading the red blood cells to multiply further. The release of the new parasites is associated with fever, shivering, and anemia.

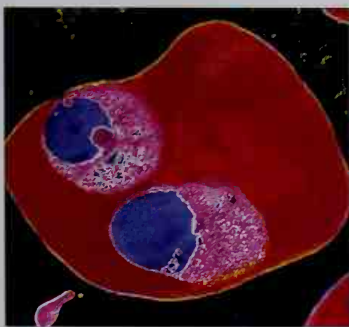

PROTOZOA

Protozoa are a class of single-celled organisms, some of which can cause disease in humans. The most important of these are the malarial parasites (shown here as two merozoites in a human blood cell) and the amoeba that causes amoebic dysentery. The group also includes the organisms that cause toxoplasmosis and sleeping sickness.

BACTERIAL INFECTIONS

Bacteria are single-celled organisms, whose shapes vary greatly (see pp. 134-135). The bacteria shown here are of part of a colony of *Legionella* organisms that cause the form of pneumonia known as Legionnaire's disease. Fortunately, antibiotics are effective against most bacteria.

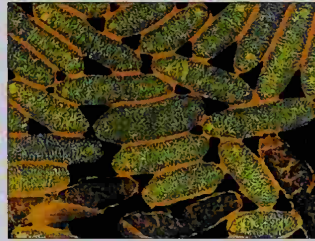

LEGIONELLA BACTERIA

FUNGAL INFECTIONS

Fungi are organisms that scavenge on dead or rotting tissue. Some can infect human beings, causing both superficial and fatal infections. The *Candida* fungus, shown below, is the cause of one of the most common, superficial human infections and is usually confined to the skin or to the mucous membranes.

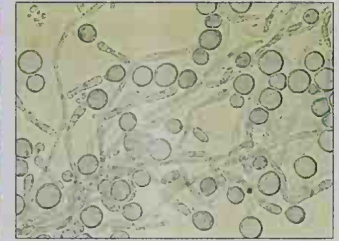

CANDIDA FUNGUS

PRION PROTEIN

Prion proteins are short lengths of normally harmless protein found in the human body. Research indicates that the principal prion disease – the brain disorder Creutzfeldt-Jacob disease – results from a modification of the normal prion protein. This involves a partial unfolding of helical parts of the protein molecule as a result of the substitution of a single amino acid for a different amino acid in the protein sequence. It can occur as a result of an inherited gene mutation, or when a slightly modified form of the normal protein enters the body and starts a chain reaction that causes the body's own prion protein in the brain to be modified.

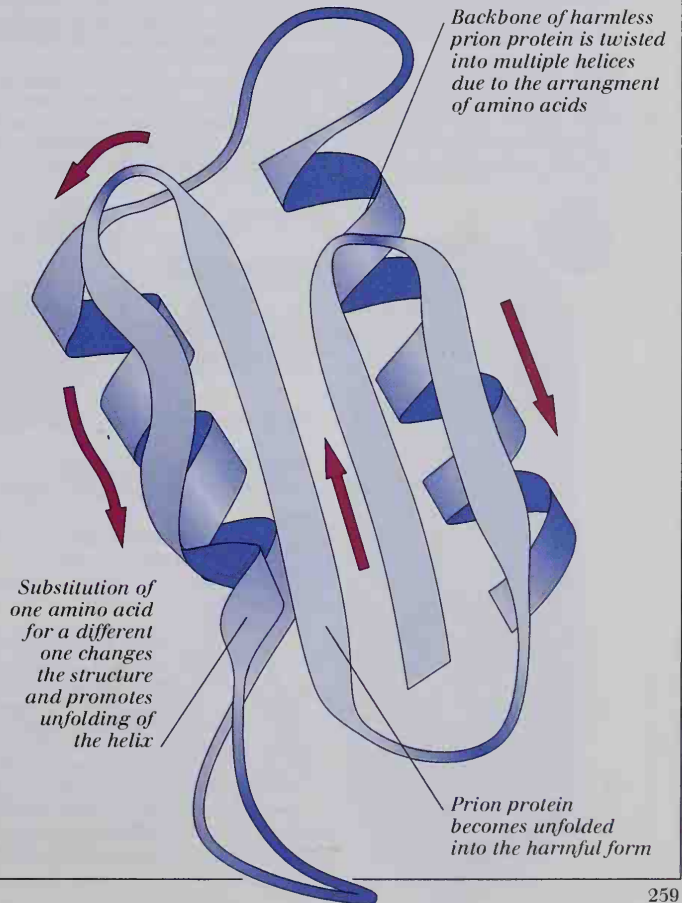

The immune system

THE IMMUNE SYSTEM PROTECTS the human body from infection. Unlike other systems of the body, it consists of a range of individual cells that are not joined together to form tissues. These cells fall into various classes including recognition cells, antibody-producing cells, killer cells, and eating or scavenging cells (phagocytes). The most important are the lymphocytes – B cells that produce antibodies, and T cells that assist B cells and also act as killer cells (see pp. 250-251). The main function of the immune system is to destroy invaders, such as germs, parasites, and biological tissue. They do this by the recognition of chemical groups called antigens. These differ from those carried by the body's own cells, so that under normal conditions the body does not turn on itself. In some instances, however, the body does attack its own cells; this is known as an autoimmune disorder. Allergies occur when the body becomes hypersensitive to certain antigens. Mast cells within the body release a cocktail of irritating substances that produce the characteristic allergic responses. The body can be artificially protected from disease by immunization.

PHAGOCYTES

These are the "eating" cells of the immune system (larger phagocytes are called macrophages). They are amoebic and perform a major cleaning-up function. When they encounter an antigen, with antibody attached, they extend pseudopodia (false feet) that surround and eventually engulf it. The phagocyte then uses oxygen free radicals to destroy the foreign material.

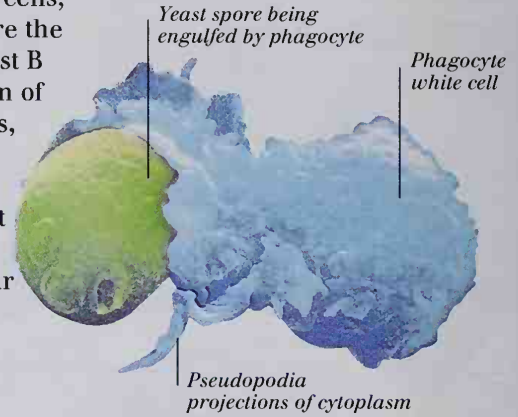

AUTOIMMUNE DISORDERS

The immune system protects the body by recognizing and destroying foreign tissue (see pp. 250-251). Normally, it is suppressed against reacting to tissues of its own body. Sometimes, however, the regulation mechanisms that ensure this suppression fail, and the immune system is left free to attack its own tissues. The resulting disorders are called autoimmune diseases. They include rheumatoid arthritis, multiple sclerosis, and various anemias. Because antigens on certain germs so closely resemble human antigens, the antibodies to them can also attack human cells. This mechanism, involving viruses, is thought to be responsible for diabetes and is shown below. If it is caught in time and the body treated with anti-antibodies, the process can be halted.

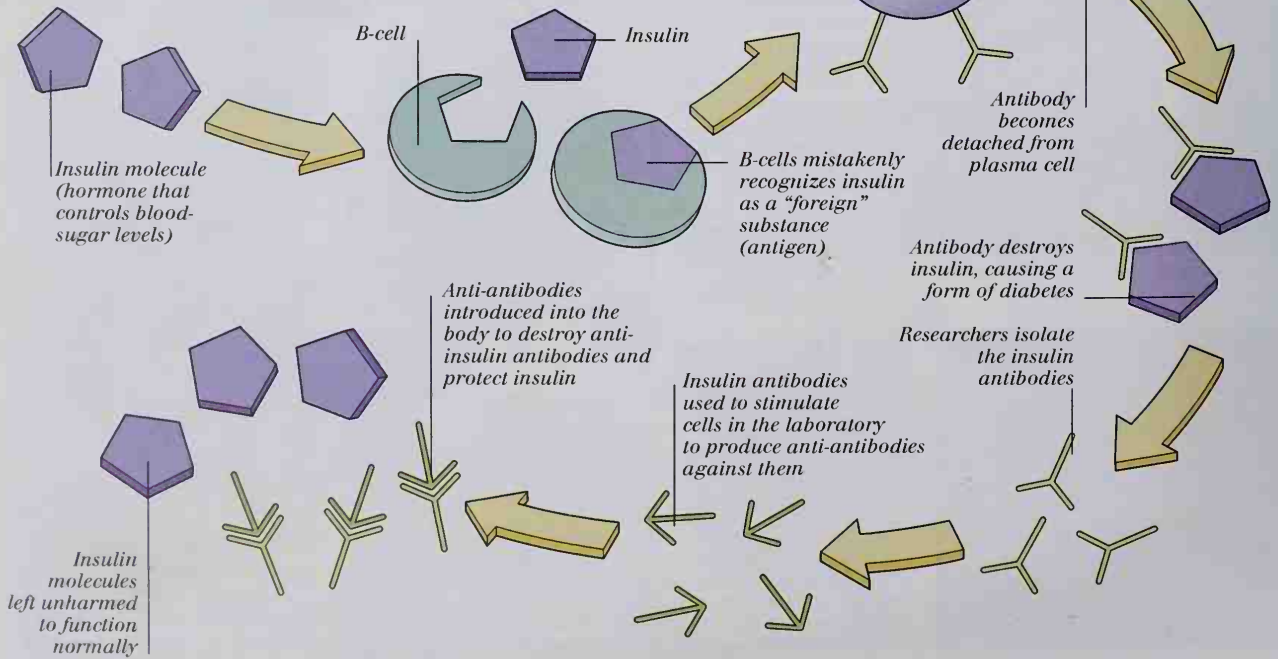

IMMUNITY

HOW IMMUNIZATION WORKS

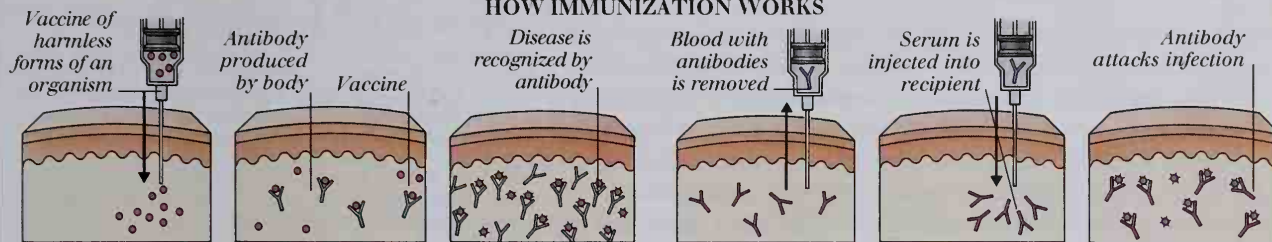

ACTIVE IMMUNIZATION

This process relies on the body's immune system producing antibodies itself. It does so in response to the administration, usually by injection, of dead or harmless forms of an organism. These can no longer cause the actual disease but still carry the antigens by which the immune system can recognize them. As a result, the body produces protective antibodies against any future infection of the same kind.

PASSIVE IMMUNIZATION

In this form of immunization, antibodies that have been formed in another individual or animal as a result of infection or immunization, are purified and concentrated into a serum. This is given to an infected person by injection. If these ready-made antibodies are of the correct type, they will immediately attack the organisms causing the infection and usually destroy them. Passive immunization can also be used to provide a short-term form of protection against disease.

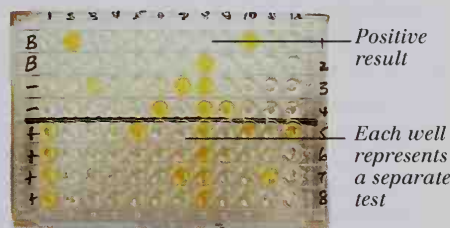

INTRODUCING VACCINES

Vaccines have proved invaluable in controlling many infectious diseases, such as whooping cough, influenza, rubella, poliomyelitis, and tetanus. In the case of smallpox, they have succeeded in eradicating the disease altogether.

Some vaccines may be given as an oral solution, but most are delivered by injection. The appropriate amount may be drawn into a disposable syringe from a multidose vial, or it may come from a prepacked, single-dose syringe, like the one shown above.

ENZYME-LINKED IMMUNOSORBENT ASSAY

The ELISA test is used to diagnose disease by the presence of antibodies. When screening for HIV, a sample of blood serum is added to an enzyme in a well on the test plate. A positive result shows the presence of HIV antibodies.

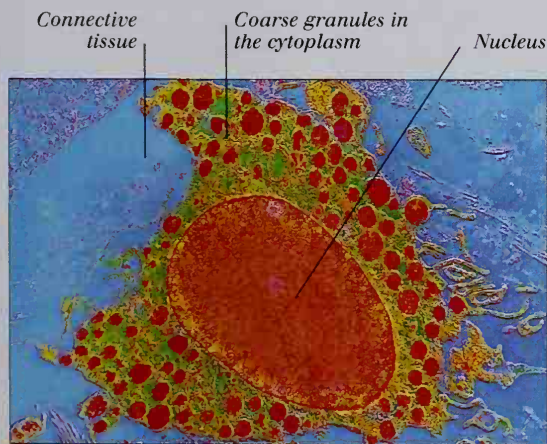

MAST CELL

Mast cells are present in most connective tissues. The cytoplasm is full of granules that contain heparin (a blood anticoagulant), histamine (a mediator of inflammation), and serotonin (also associated with inflammation). These are released during an allergic response, causing typical symptoms of allergy - widening of blood vessels, swelling of tissues, excessive nasal and eye secretion, and the tightening and narrowing of air passages in the lungs.

ALLERGY

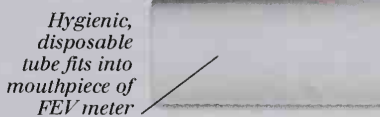

Patient blows hard into mouthpiece

Forced expiratory volume in 1-second measurement is displayed

Control and reset buttons

Compact, portable FEV meter can be used in doctor's surgery

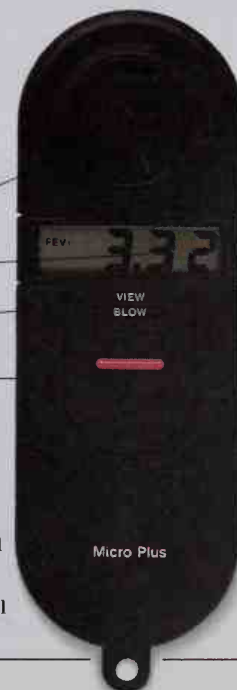

MEASURING LUNG FUNCTION

Asthma is an allergic condition in which the air passages in the lungs are narrowed by the spasming of involuntary muscles and the inflammation of the mucous membrane. FEV (Forced Expiratory Volume) meters are used to check the freedom with which air can be expelled from the lungs. When blown into, they measure the rate of airflow and equate it with the peak volume passing in a given time. This can give vital information about the condition of the sufferer.

Genetics and medicine

IN THE LAST YEARS OF THE 20TH CENTURY, genetics has become the most important of the basic sciences underlying medicine. Advances in genetics, in particular the location of genes responsible for disease and the determination of the **genetic code** of large parts of the human genome – the whole genetic basis of an individual – have revolutionized modern medicine. Scientists predict that all of the human genome will be sequenced within a few years and that the location and exact detail of all the human genes – for normal characteristics and for disease – will soon be known. Genes can now be made artificially and incorporated into living cells. Any gene can be cloned to produce large numbers of perfect copies. Theoretically, such genes can be used to replace abnormal (mutant) genes to prevent or cure serious **genetic disorders**. Genetic engineering is also used to produce an ever-increasing number of **biochemicals** for use as drugs or vaccines. These substances are replacing medication that, because of the way it was obtained or made, could not always be relied upon to be pure and safe; for example human growth hormone, which has been implicated in the transfer of Creutzfeldt-Jacob Disease (CJD) (see pp. 258-259).

GENETICALLY ENGINEERED DRUGS

Many drugs, such as insulin, are produced naturally in the body. In the past, such drugs were obtained from animals and, as a result, were often significantly different from the human version. Many of these drugs can now be produced by genetic engineering. The illustration below shows the equipment that is used to grow the microorganisms into which the human gene for the desired product has been inserted. By this method, massive culturing of the organism and large quantities of the resulting drug can be obtained.

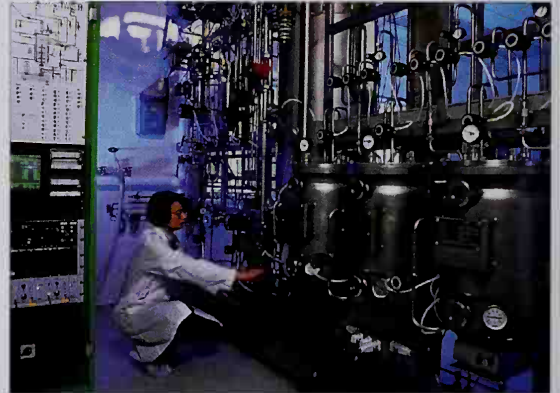

HOW GENETIC ENGINEERING WORKS

Scientists have discovered several hundred different enzymes that can selectively cut the DNA molecule at particular points. Because the action of these enzymes results in restricted lengths of DNA, they are called restriction enzymes. Many of the DNA lengths cut out in this way are single genes that code for a particular protein, such as insulin. These genes may then be incorporated into the **plasmid** of a bacterium using certain other enzymes. The bacterium will then be capable of synthesizing the required protein. Bacteria can be cultured in enormous numbers to facilitate the production of large quantities of the protein. For a "foreign" gene to be expressed in a new host, such as an animal cell, it must be carried into the cell in a DNA molecule; bacterial plasmid DNA is commonly used for this.

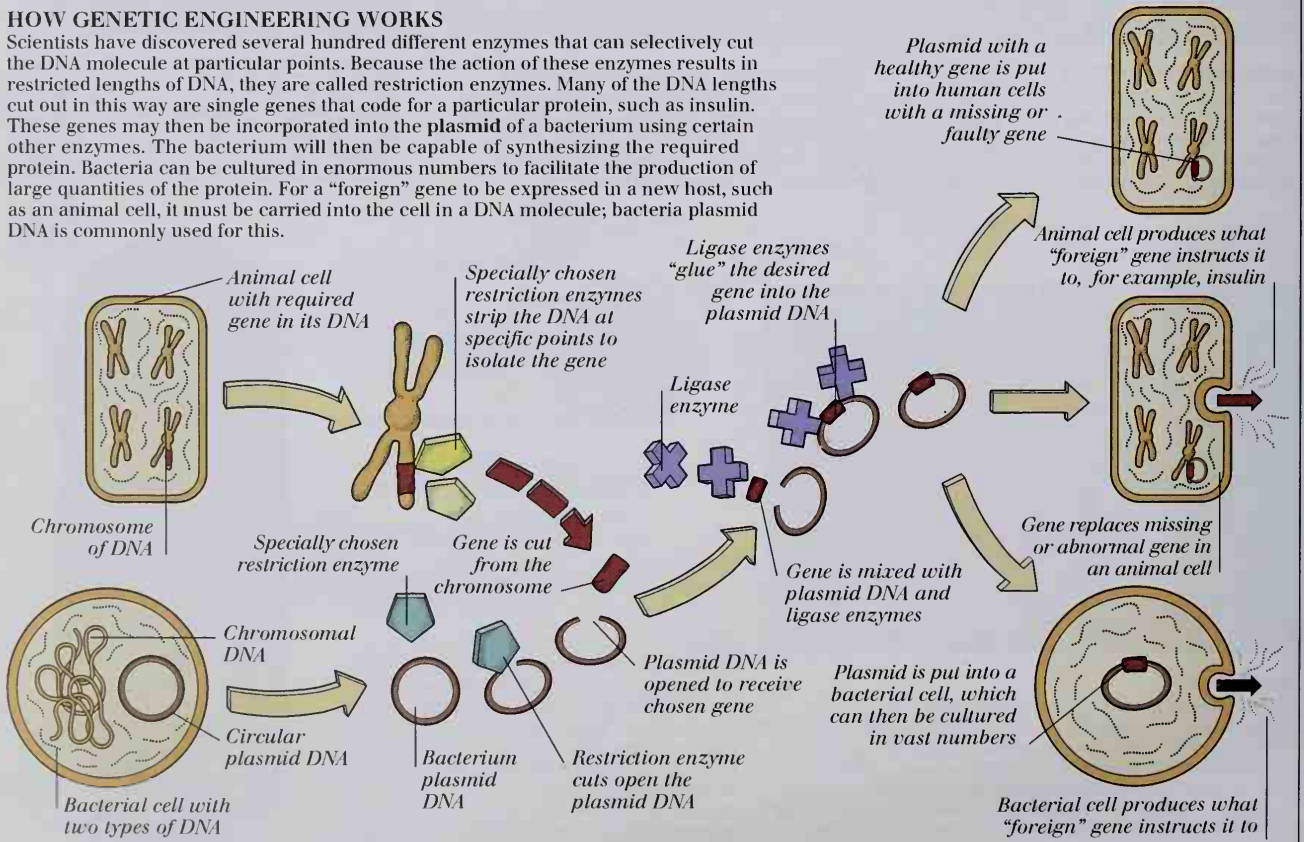

CHROMOSOMAL ABNORMALITIES

Human karyotype has 23 pairs of chromosomes



An extra chromosome 13 causes Patau's syndrome

An extra chromosome 21 causes Down's syndrome

An extra chromosome 18 causes Edward's syndrome



Two copies of the human X sex chromosome stuck together at the stage used to form a karyotype

Mutation in gene in this area causes Duchenne muscular dystrophy

Genetic mutation here affects the eyes

Mutation in gene here causes a cleft palate

Mutation in gene here causes hemophilia (a disease that affects clotting in the blood)

Mutation here causes the skin disease ichthyosis (fish-skin disease)

Mutation in gene here causes color blindness

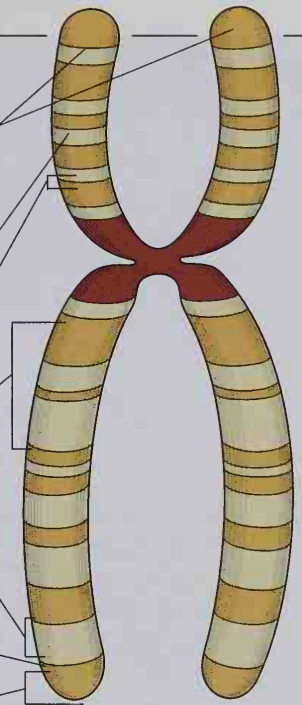

EXTRA CHROMOSOMES IN THE HUMAN KARYOTYPE

Healthy eggs and sperms each have 23 pairs of chromosomes. However, numerical chromosomal abnormalities can occur. These usually originate during cell division, when eggs and sperm are formed. An extra

chromosome can appear as a result of abnormal separation at the stage of cell replication. This is called trisomy, and it most commonly affects chromosomes 21 (trisomy 21), 18 (trisomy 18), and 13 (trisomy 13).

GENE MUTATIONS IN THE HUMAN X CHROMOSOME

Mutations are changes in the sequence of bases in the chromosome. They occur due to deletions of bases or substitutions of the wrong base. Such changes result in abnormalities in the proteins, usually enzymes, for which the genes code. The X sex chromosome is particularly prone to genetic mutations.

GENETIC ANALYSIS

DNA FINGERPRINTING

This is a recording of a pattern of bands unique to each unrelated individual but with common features in related people. The bands, which are produced using restriction enzymes, electrical-attraction sorting, and radioactive DNA probes, correspond to regions in the DNA called core sequences. Bands are produced on photographic film by the action of radiation. DNA fingerprinting can be used for paternity testing and has great forensic significance. Only a tiny sample of blood, semen, or any body tissue is needed to provide the DNA for the procedure.

Band corresponds to core sequence in the DNA

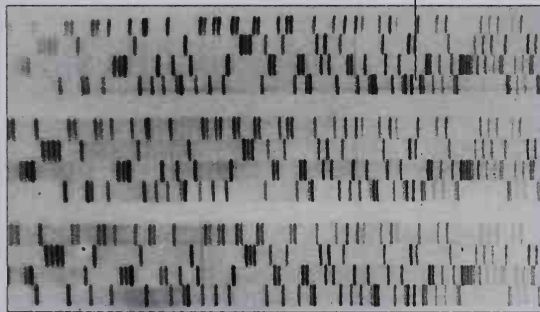

MAPPING THE HUMAN GENOME

The human genome project is one of the greatest scientific enterprises of all time. Its purpose is to discover the base sequence of the complete human DNA molecule – all the genetic information of the human organism. The development of automated machinery to carry out the sequencing has greatly sped up the project, which is now nearing completion. It has already increased knowledge of human genetics, and it is also transforming medicine.

Part of a computer screen display showing the sequence of the initial letters of the four bases (G, C, A, and T)

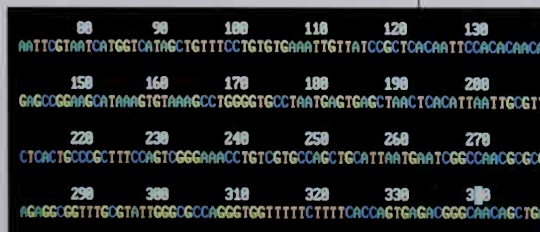

GENETIC CLONING

The cloning of an animal, such as Dolly the sheep (see below), involves the insertion of the whole DNA (genome) from a donor cell into the nucleus of an ovum from another animal. First, the ovum is isolated and its nucleus – which contains a complete copy of the DNA – is removed. Then, in its place is inserted the whole DNA taken from a cell from a donor animal. Because the whole genome has come from a donor, the resulting individual is a clone (identical copy) of the donor.





Satellite image of the Earth

EARTH SCIENCES

DISCOVERING EARTH SCIENCES	266
GEOLOGICAL TIME	268
THE EARTH	270
PLATE TECTONICS	272
EARTHQUAKES AND VOLCANOES	274
FAULTS AND FOLDS	276
ROCKS AND MINERALS	278
ROCKY LANDSCAPES	280
GLACIERS AND ICE SHEETS	282
RIVERS	284
COASTLINES	286
OCEANS	288
THE ATMOSPHERE	290
WEATHER	292



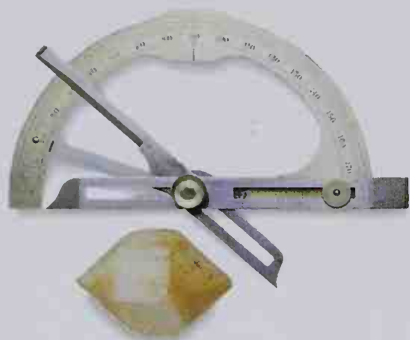

MEASURING ANGLES

One way in which scientists are able to identify crystals is by measuring the angle between corresponding faces of a particular mineral. They do this with a device (shown above) called a goniometer.

Discovering earth sciences

THE EARTH SCIENCES INVOLVE THE STUDY of the Earth's rocks and minerals, water, and atmosphere. These fields include geological science, hydrological science, and atmospheric science. Geological science is the study of landforms, rocks, and minerals. Hydrological science includes the study of oceans, rivers, and glaciers. Atmospheric science deals with the study of weather (meteorology) and climate.

ANCIENT IDEAS

Ancient people put forward untested explanations for natural phenomena, such as the weather, the tides, and earthquakes and volcanoes. For example, several writers suggested that earthquakes and volcanoes are caused by hot wind that circulated underground. The occurrence of seashells on the tops of mountains was explained by hypothesizing catastrophic global floods. For all their mistaken ideas, many ancient natural philosophers made excellent observations. For example, the link between the tides and the motion of the Moon was noted around 100 BC. The study of earthquakes (seismology) began in ancient China.

Astronomer and geographer Chang Heng invented a seismograph that was used to keep comprehensive records of seismic activity. Also, many people had a good knowledge of geological science. For example, some Roman architects could find locations that were likely to supply large quantities of groundwater by recognizing particular rocks and land

formations. The spirit of inquiry and ingenuity that the ancient Greeks, Romans, Chinese, and Arabs possessed, and that served them so well in their investigations of natural phenomena, appears to have been lost during the Middle Ages. However, much of what they wrote survived and helped to inspire new investigations during the Renaissance period in Europe.

ROCKS AND MINERALS

Ancient civilizations were able to distinguish between common rock types. In particular, they were able to identify those ores from which they could smelt metals. After the Middle Ages, in 1546, Georgius Agricola produced the first scientific textbook on geological science. It included a classification of rocks and minerals. Many people gave thought to the actual origins of rocks and minerals. In 1669, Niels Stensen suggested that rocks are laid down in the ocean by sedimentation. His theory correctly suggested that the strata (layers) of sedimentary rocks provide a record of the Earth's history. He was also the first geologist to suggest that fossils were the remains of ancient plants and animals – this idea was crucial to Darwin's theory of evolution some 200 years later. During the 18th century, a debate raged between two rival theories of rock formation. Both theories involved Stenson's idea of sedimentation. One theory was that the Earth was originally covered with ocean and that all the rocks were laid down at the same time. The opposing theory involved a notion similar to the modern idea of the rock cycle. It claimed that the heat of the Earth forms lava, which solidifies to produce igneous rocks.

A CHINESE SEISMOGRAPH

Seismology originated in China. This seismograph is equipped with a brass ball that tumbles out from a dragon's head into a frog's mouth when the Earth is disturbed. The head from which the ball emerges points to where the earthquake has occurred.



Rain and rivers erode these igneous rocks, depositing them in the ocean, where they form sedimentary rocks. The heat of the Earth then melts the sedimentary rocks to form igneous rocks once again.

WATER CYCLE

Most ancient thinkers were aware of at least parts of the water cycle. Aristotle had reasoned that water becomes air as it evaporates and turns to water again in the air to form clouds. But like all philosophers of his time, he did not realize that this process transported enough water from the ocean to mountaintops to form rivers. Until the 17th century, most thinkers assumed that seawater was somehow transported to the mountains underground. It was not until scientists began making careful estimates of the weight of water at each stage of the water cycle – including measurements of the rate of evaporation – that the truth became clear. Some people, however, still disbelieved the claim that water from the oceans could form clouds. The invention of the air pump in the 17th century helped to convince them of evaporation, especially when artificial clouds were produced in laboratories by reducing the pressure of humid air to that of air at the level at which clouds form.

PLATE TECTONICS

Plate tectonics – the theory that the Earth's crust consists of several moving sections, or plates, which may be driven by convection currents in the mantle – rests

upon two main observations. In 1912, Alfred Wegener observed that separate continents looked as if they were once joined. He suggested that the continents had once been connected together, forming one vast landmass, which he called Pangaea. This continental drift theory accounted for many puzzling observations. For example, it had been noted that fossils of ancient animals that lived about 200 million years ago were found in Africa and Australia. The fossil records of these two landmasses are different only where they are records of later periods in the Earth's history. Living things in the two regions would have evolved differently after the continents split, explaining the inconsistency of the fossil record since then. The second observation came in 1960, when the seabed was shown to be spreading in certain places. The rate of this seabed spreading has been measured with extreme accuracy using global positioning satellites. Later, in the 1960s, Canadian geologist John Tuzo Wilson revived Wegener's continental drift idea, combining it with seabed spreading and his own new theory of fault formation in the Earth's crust. The result was the plate tectonics theory, which revolutionized the geological sciences during the 1970s.

METEOROLOGY

Another area of the Earth sciences that advanced rapidly during the 20th century is meteorology, the study of weather. Scientific weather prediction dates back to the invention of the mercury barometer in the 17th century. Meteorologists noticed that local atmospheric pressure rose and fell before and after changes in the weather. However, these predictions were crude. More sophisticated predictions could be made only with knowledge of wind speed and direction, and with pressure and temperature measurements taken over a wide area. In the 19th century, the invention of the telegraph enabled the coordination of measurements from weather-monitoring stations across whole continents. New technology at the disposal of meteorologists during the 20th century includes weather balloons, weather radar, airplanes, and of course, satellites.

THE CIRCUMFERENTOR

This very highly decorated circumferentor was used to compare angles and so figure out how far away distant objects were. This proved particularly useful during early mapmaking. The example shown here was made in 1676.



TIMELINE OF DISCOVERIES

550 BC	Anaximander of Miletus proposes that the Earth is a cylinder
240 BC	Eratosthenes assumes the Earth to be spherical and figures out a fairly accurate value for its circumference
AD 132	Chang Heng invents the first seismograph
1669	Neils Stensen suggests that rocks are laid down in horizontal layers
1755	George Hadley formulates theory of wind circulation in the Earth's atmosphere
1779	Horace de Saussure coins the term "geology"
1785	James Hutton suggests that geological processes are slow and continuous, and that the Earth has existed for millions of years
1815	William Smith provides evidence for "faunal succession" – different plant fossils existing in different types of rocks – which leads to the idea of geological eras
1822	Friedrich Mohs introduces his scale of hardness of minerals
1857	Jean Louis Agassiz uses the term "Ice Age" when suggesting that Europe was once covered in glaciers
1880	John Milne invents the modern seismograph
1897	Analysis of waves in a violent earthquake leads Richard Oldham to suggest existence of the Earth's core
1902	Oliver Heaviside suggests the existence of a layer of ions (charged particles) in the atmosphere. This layer is now called the ionosphere
1904	Vilhelm Bjerknes pioneers scientific weather forecasting
1912	Alfred Wegener proposes the theory of continental drift
1915	Charles Fabry discovers the ozone layer
1955	The Richter scale for measuring the magnitude of earthquakes is introduced by Charles Richter and Beno Gutenberg
1962	Harry Hess develops the theory of plate tectonics

Geological time

THE EARTH FORMED SOME 4.6 billion years ago from a vast cloud of gas and dust. At first, it glowed red-hot, and the Earth's surface was a seething mass of volcanoes and smoke (see pp. 274-275). Gradually, however, the Earth began to cool, and its atmosphere began to clear as rain fell and created oceans (see pp. 288-289). The first microscopic life forms appeared almost 3.6 billion years ago. Some 5 billion years ago, large continents began to form. These have changed shape and fragmented continually ever since, as the Earth's surface has shifted, forming rocks and breaking them down again and again (see pp. 272-275). As plantlike organisms called algae evolved and multiplied, they added oxygen to the atmosphere; this allowed, eventually, for more complex life forms to emerge, marking the end of the Precambrian era – the long Dark Age of the Earth's first 4 billion years.

FORMATION OF THE EARTH

The Earth probably formed as tiny pieces of space debris called planetesimals gathered together into a lump. This lump grew as more space debris smashed into it. Among the materials added by these impacts was water ice, from the edge of the solar system.



RADIOCARBON DATING

Geologists use a technique called radiocarbon dating – which relies on measurements of radioactive decay – in order to determine the age of organic remains. Carbon-12 and carbon-14 are present in all living things, but carbon-14 decays into nitrogen-14 at a known rate when an organism dies. After 5,730 years, half of the carbon-14 remains; after another 5,730 years, only a quarter remains; and so on. Geologists arrive at a figure by measuring the ratio of carbon-14 to carbon-12.

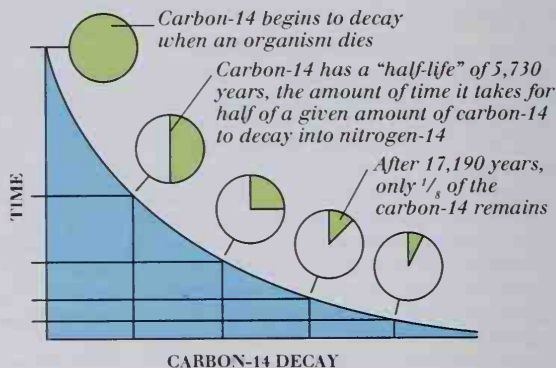

EVOLUTION OF THE EARTH

Geologists know a great deal about how the Earth, and life upon it, has changed over the last 570 million years. They know this from the fossilized remains of creatures buried over time in layer upon layer of sediments. If these sediments had remained undisturbed, it would

be possible to cut a column down through the layers to reveal the entire sequence right up to the present day. This sequence is called the geological column. The illustration below shows what the Earth would have been like as each layer of sediment was laid down.

EARLIER PALEOZOIC ERA

Algae and invertebrates flourished in the oceans and the first complex organisms appeared, followed later by crustaceans and early fishlike vertebrates. Around 458 mya, the continents began to drift together slowly to form the super-continent, Pangaea. Simple plants began to colonize the land.

PRECAMBRIAN ERA

Little is known about the first 4 billion years of the Earth's history, but during this period the first microscopic, single-celled life forms appeared, then, much later, multi-cellular, soft-bodied animals.

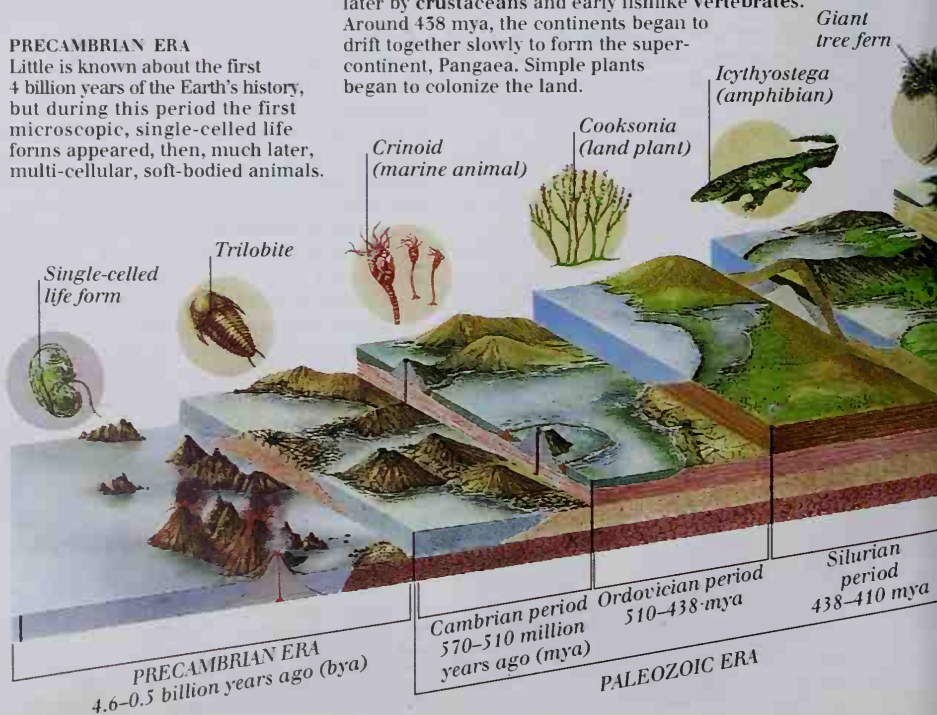

FOSSIL FORMATIONS

Fossils are the remains of living things preserved in rock. When a creature such as a shellfish falls onto the seafloor, its soft body tissue decays quickly, but its hard shell may be buried intact by sediments. Over millions of years, the shell may be preserved virtually unaltered. At other times, minerals forming the shell may dissolve, leaving a mold that is filled in with other minerals, thus preserving the original form.

Most fossils are of shellfish that lived in shallow seas, although many other types may be preserved

Fossils are destroyed by pressure and heat when they sink to a certain depth

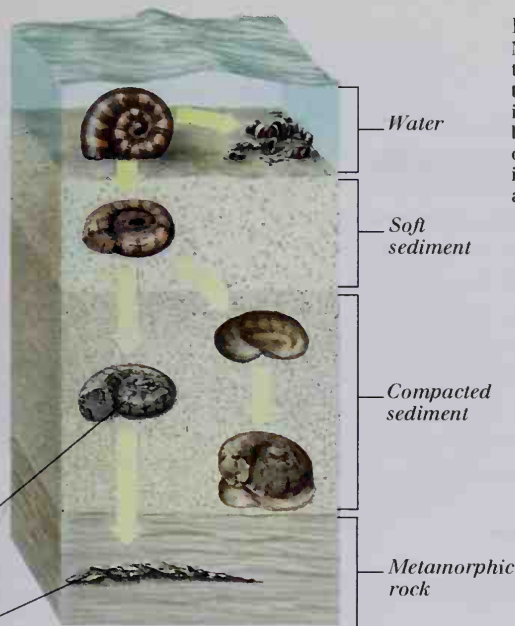

INDEX FOSSILS

Most fossils are of small, shelled sea creatures, because these creatures have a high chance of fossilization when their shells become buried in the seafloor. Particularly important are index fossils, which are used to date rocks because they are abundant, easy to identify, and appear only in particular time periods. Examples of index fossils include ammonites (of the Jurassic and Cretaceous periods) and trilobites (of the Cambrian period).



Trilobite fossil from the Cambrian period

The trilobite is an extinct sea creature with a hard, flexible shell divided into three parts

LATER PALAEOZOIC ERA

Arthropods appeared on land, and fish swarmed the sea. Spore-bearing plants grew as big as trees, and the first amphibians appeared. By 355 mya, vast forests flourished in river deltas, eventually forming coal deposits. By 290 mya, the first reptiles had appeared. Pangaea formed from the collision of Laurasia and Gondwana, and the world climate cooled as ocean currents were disrupted by tectonic-plate movement.

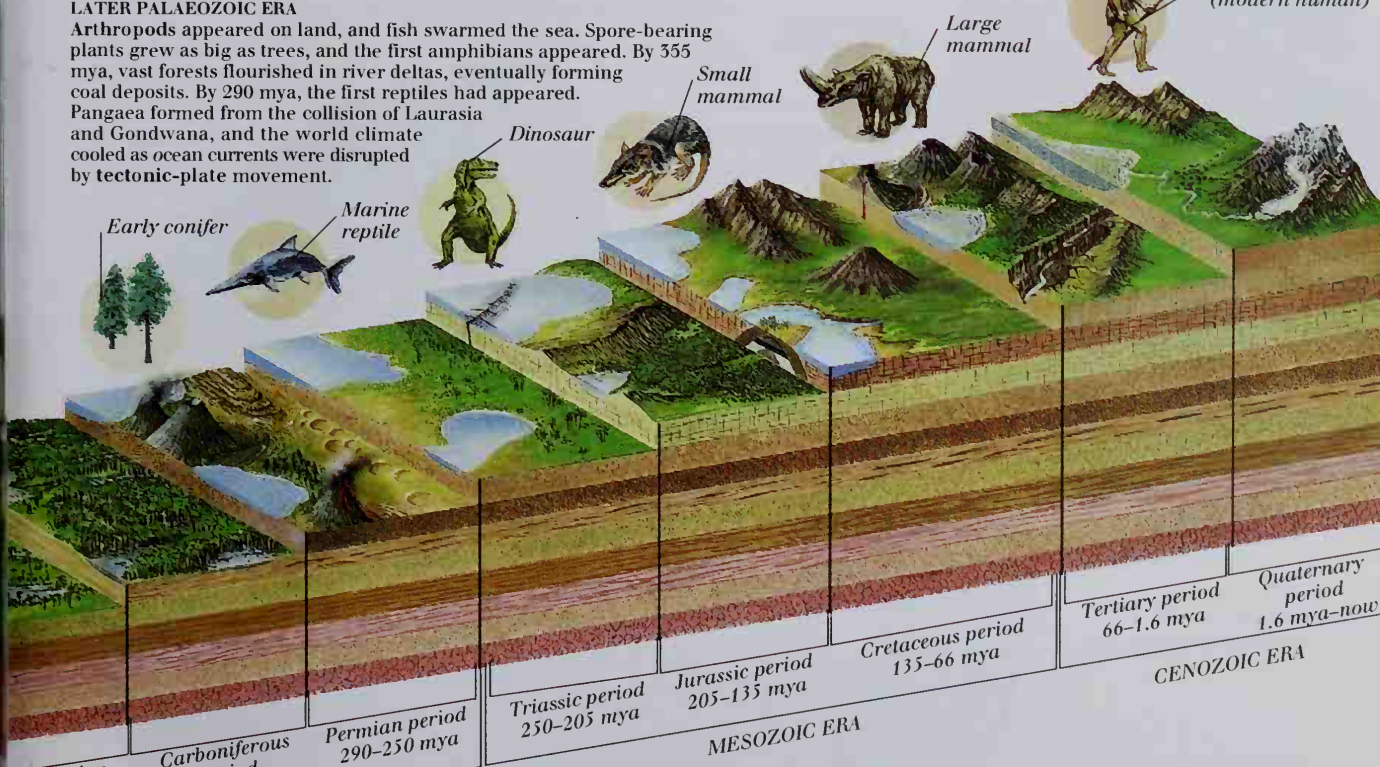

MESOZOIC ERA

The era began with the mass extinction of around 90 percent of all species. Seed-bearing plants began to dominate. The Jurassic period was the era of the dinosaurs. By the late Jurassic, *Archaeopteryx*, the first bird, had evolved. The Atlantic Ocean began to form, dividing Pangaea. After 135 mya, flowering plants and small mammals appeared, and oil and gas deposits began to form from the remains of sea creatures. The dinosaurs died out suddenly at the end of the era.

CENOZOIC ERA

Mammals began to diversify widely. Primates evolved, grasslands expanded, birds flourished, and the continents took on their present form. Habitats continued to alter with the shift of the continents and the changes in climate. Modern humans appeared toward the end of the era.

The Earth

THE EARTH IS A not-quite-perfect sphere of rock with a metal core, wrapped in a blanket of gases called the **atmosphere**. It is 12,756 kilometers in diameter and 40,075 kilometers in circumference (at the equator). It orbits the Sun once every 365.242 days, traveling 959,886,400 kilometers, and rotates on its axis once every 24 hours, spinning much faster at the equator than at the poles. The result is that the planet bulges slightly at the equator and is flattened at the poles. The Earth is the only planet in the solar system (see pp. 304-305) that is known to support life. This is because, unlike the other planets, there is an abundance of liquid water on the Earth's surface, and a significant amount of oxygen in its atmosphere.

ROCKS FROM SPACE

The Earth is made of material similar to that of meteorites (see pp. 322-323). Meteorites usually consist of silicate materials similar to those of the Earth's mantle (stony meteorites) or iron, like the Earth's core (iron meteorites).



A chondrite (a type of stony meteorite)

STRUCTURE OF THE EARTH

The Earth has four main layers. The inner and outer cores are metallic, composed mostly of iron. The mantle is made from silicate minerals. Its lower part is made from solid, closely packed crystals. Its upper part is partially molten and is the source of most of the Earth's **magma**. The crust is the thin outer layer. The interior of the Earth is hot. This heat is left over from the time of the Earth's formation and is added to by nuclear reactions deep inside the planet.

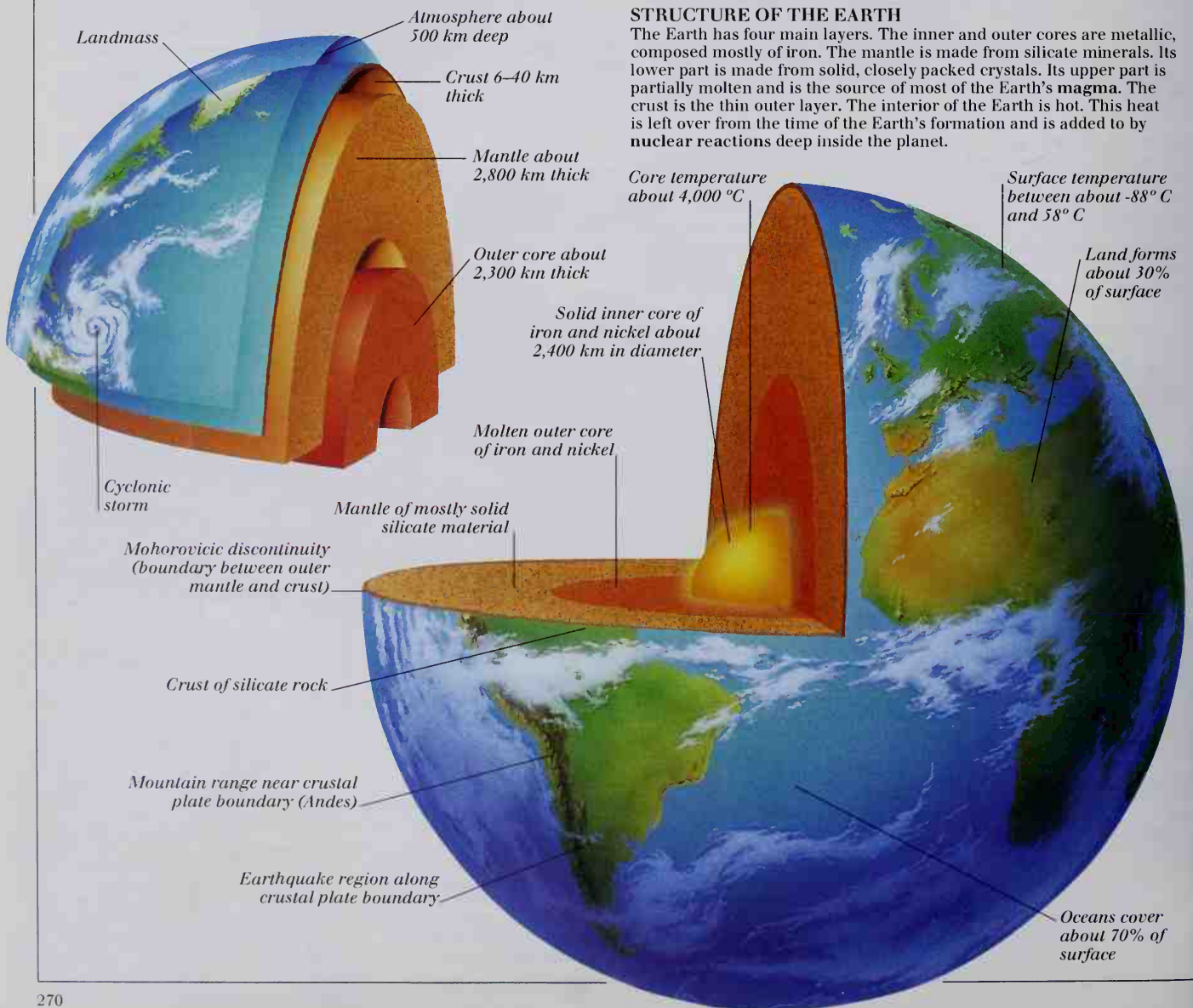

SEASONAL CHANGE

The Earth's axis is tilted at an angle of 23.5° to the Sun. As the Earth orbits the Sun, different zones of the Earth lean in turn gradually nearer to the Sun and then farther away, creating four distinct phases, or seasons.

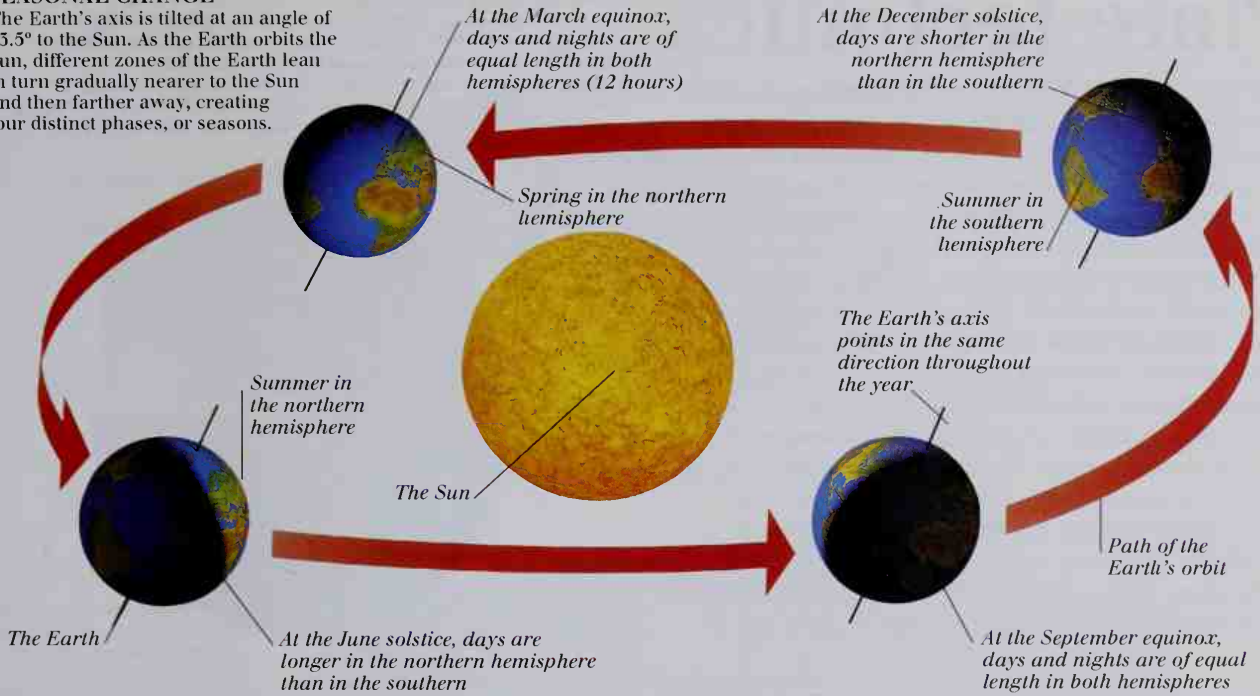

THE EARTH'S MAGNETIC FIELD

THE EARTH'S MAGNETOSPHERE

The Earth's magnetic field affects electrically charged particles in a region called the magnetosphere, which extends up to 60,000 km into space. The magnetosphere is "stretched" far out into space by the solar wind, a stream of charged particles emanating from the Sun.

THE EARTH'S MAGNETIC POLES

The Earth's magnetic field is created by convection currents in the molten outer core. These are continuously cycling and create electrical currents, which turn the planet into a giant magnet. Like a bar magnet, the Earth has two magnetic poles, which are situated near to the geographic North and South Poles.

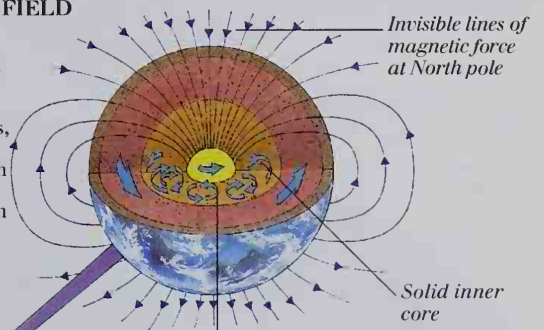

Heat and pressure within the Earth cause the liquid outer core to move continuously

Solar wind composed of charged particles from the Sun

Some particles are drawn in toward the poles

Magnetosphere (magnetic field)

The boundary of the magnetic field is known as the magnetopause

The magnetotail is where the magnetic field is drawn away by the solar wind

Plate tectonics

THE EARTH'S OUTER SHELL, or **lithosphere**, is not a single, solid piece, but is cracked, like a broken eggshell, into a number of giant fragments called tectonic plates. These are composed of crust and the upper part of the mantle. The continents are embedded in these plates, which are moving slowly but inexorably – pulling apart, smashing together, or sliding past each other. As they jostle to and fro, they split continents apart and open up new oceans – all of the world's continents were once joined in a single supercontinent called Pangaea. They can also push continents together, crumpling up layers of rock into giant mountain ranges. The interaction of the tectonic plates is also behind some of the world's most spectacular natural events, such as earthquakes, which are set off by tectonic plates rumbling past each other, and volcanic eruptions, most of which occur where one plate meets another (see pp. 274-275).

CONVECTION CURRENTS

The movement of the tectonic plates may be driven by the slow churning of the mantle. Mantle rock is constantly being driven up toward the surface by the enormous temperatures below, which generate huge convection currents that extend right through the mantle. As it nears the surface, the mantle rock then cools and sinks back down. This whole process takes place over millions of years.

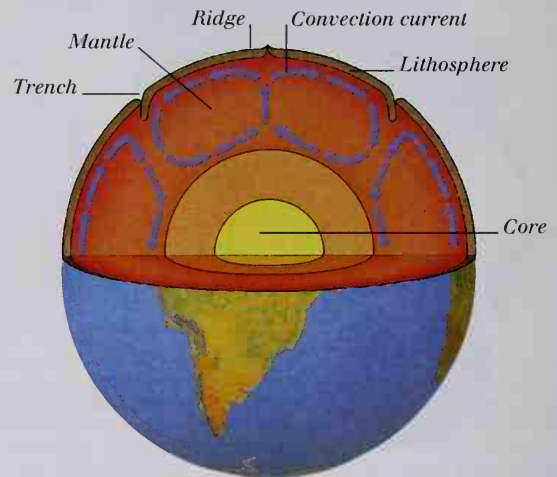

MAJOR PLATES OF THE EARTH'S CRUST

The rigid surface of the Earth is split into around eight large plates and ten or so smaller ones. The continents are formed from thick pieces of crust, which are embedded in the lithospheric plates and ride around on them as if on a raft. Oceanic crust is much thinner. The movement

of these plates is very slow in human terms, but can be quite rapid in geological terms (see pp. 268-269). The gradual pulling apart of the Eurasian and North American plates is currently widening the Atlantic Ocean by around 20 mm every year.

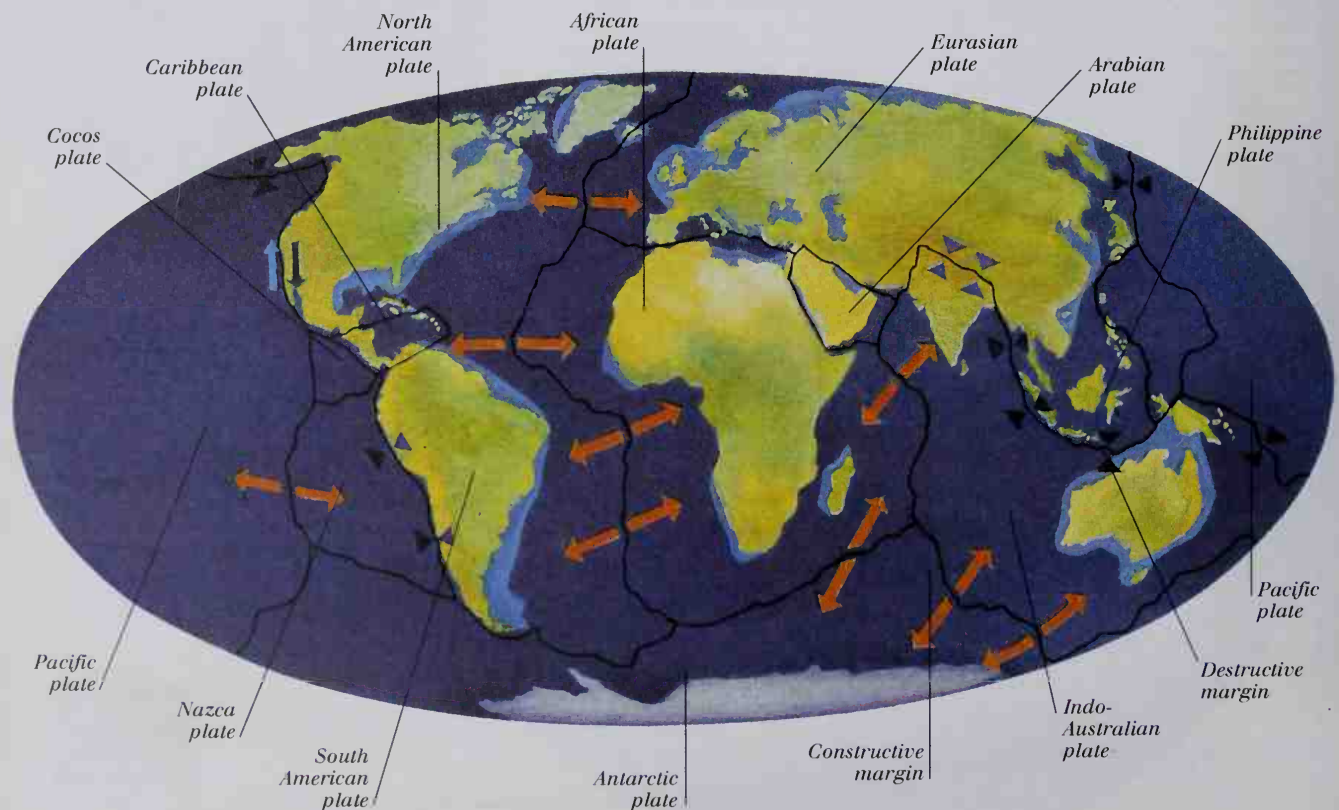

CONVERGING AND DIVERGING PLATES

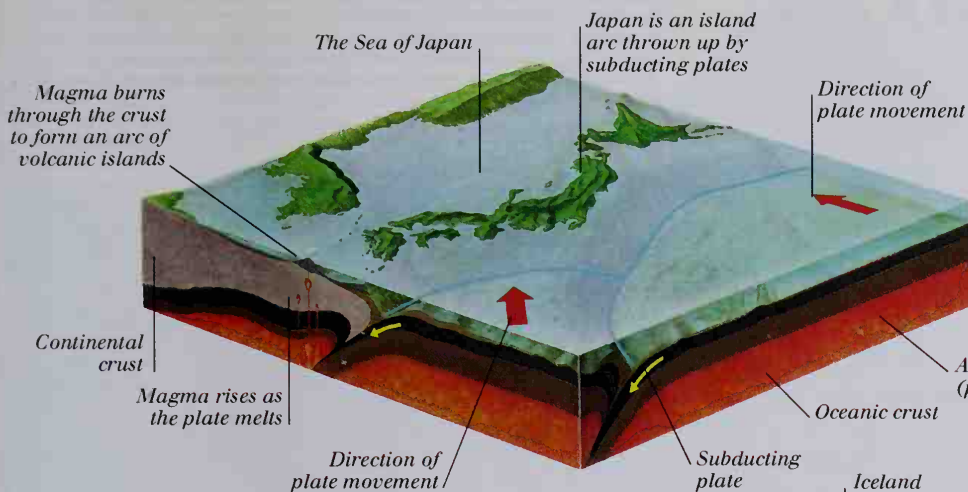

WHEN PLATES COLLIDE
Subduction is the process whereby one tectonic plate runs into another and is forced beneath it. This usually occurs where dense oceanic lithosphere meets lighter continental lithosphere, such as around Japan. As the oceanic lithosphere dips beneath the continental lithosphere, it slides into the asthenosphere, a layer of the Earth so hot that the subducted plate melts (see pp. 270-271). This is why the area where the two plates meet is called a destructive margin.

WHEN PLATES DIVERGE
In some places, mostly under the world's great oceans, tectonic plates are pulling apart. As they diverge, they allow molten rock to rise up from the mantle and add new material to the lithosphere, replacing that lost by subduction. The area where this occurs is called a constructive margin.

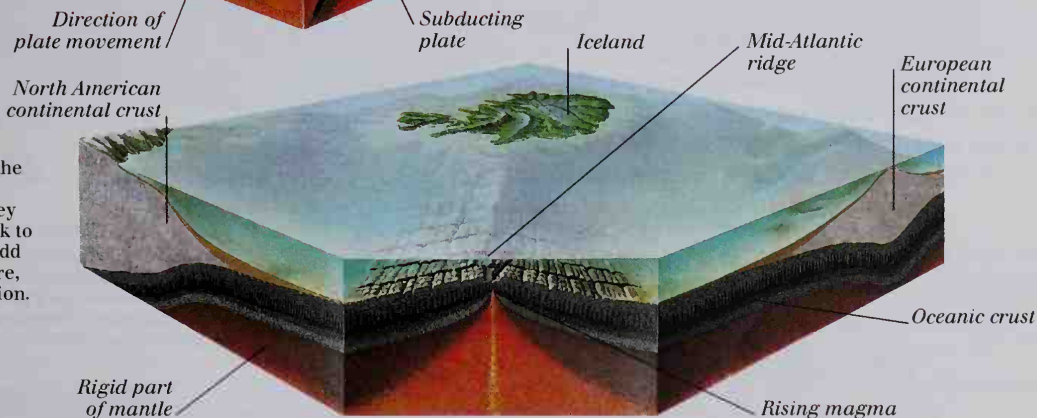

THE DEVELOPMENT OF THE CONTINENTS



220 MILLION YEARS AGO
All the continents are joined in a single supercontinent that geologists call Pangaea.



180 MILLION YEARS AGO
Pangaea starts to split apart, with the formation of the Tethys Ocean, and the Atlantic Ocean starts to form. India moves northward.



10 MILLION YEARS AGO
Antarctica and Australia drift apart. Laurasia breaks up as the North Atlantic Ocean opens up, with North America moving away from Europe. This map of the world looks similar to the one we know today.

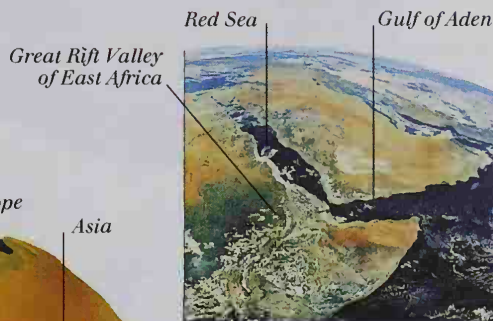

TODAY
Sometimes plates split apart right in the middle of continents, breaking them in a Y-shaped, triple junction. This happened in the crook of West Africa, when South America broke away. It is happening now in a triple junction formed by the Red Sea, the Gulf of Aden, and the Great Rift Valley of East Africa (see above).

Earthquakes and volcanoes

THE CONTINUAL MOVEMENT of the gigantic plates that make up the Earth's surface creates two kinds of disturbance – earthquakes and volcanoes (see pp. 274-275). Earthquakes start as the plates rumble past each other, sending shock waves radiating through the ground. There are over a million earthquakes a year around the world. Most are so small that they can hardly be felt, but a few are so violent that they can cause extensive damage over a wide area (see Richter/Mercalli Scale in Useful data). Volcanoes, too, are very variable. (A volcano is a place where molten rock from the Earth's red-hot interior forces its way to the surface.) In some places, the molten rock emerges slowly and gently. In others, it explodes onto the surface in a violent eruption.

EARTHQUAKE AND VOLCANO LOCATIONS

Most earthquake and volcano activity is concentrated along the boundaries of the Earth's tectonic plates – where the plates are crunching together, breaking apart, or rumbling past each other. The Pacific Ocean forms one large plate and its edges, known as the "ring of fire," have more earthquakes and land-based volcanoes than anywhere else in the world.

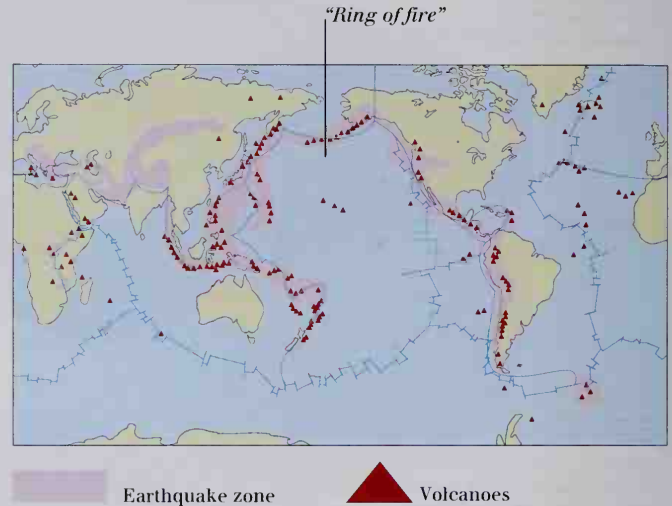

STRUCTURE OF AN EARTHQUAKE

Fast-moving P- or pressure waves pass through the Earth's mantle and core

Mantle

Inner core

Outer core

Earthquake focus

Slow-moving S (secondary) waves pass only through the Earth's mantle

Plates can often jam as they slide past each other, so stress builds up until the rock cracks and the plates rumble on, sending out shock waves

P-waves are refracted by the Earth's core, creating shadow zones where no waves are received

SEISMIC WAVES

Earthquake damage occurs as the result of seismic waves at the surface of the planet. Waves that occur far below ground can travel right through the body of the Earth. Geologists record these "body" waves on seismographs stationed around the world, and have been able to build up a detailed picture of the Earth's interior by analyzing the way in which these waves are deflected.

MEASURING EARTHQUAKES

Seismometers monitor seismic waves at strategic points around the world. The information gathered is transmitted to a recording station, where it triggers a seismograph. This records changes in seismic waves, most commonly as a recorded signal.



As the shock waves travel away from the epicenter, destruction diminishes

HOW AN EARTHQUAKE WORKS

The vibrations of an earthquake radiate out from a point underground called the hypocenter, or focus, which may be anything from just a few hundred meters to around 700 km below the surface. It is only when the vibrations reach the surface that they begin to do any real damage. The surface vibrations ripple out from a point directly above the hypocenter called the epicenter.

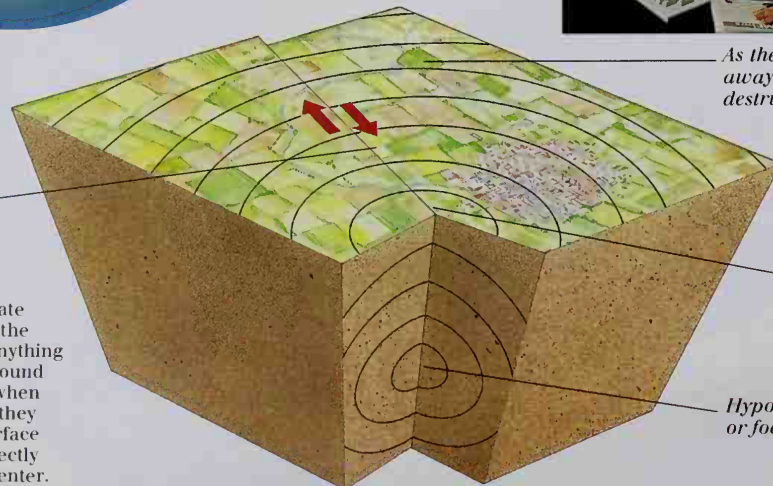

Hypocenter or focus

STRUCTURE OF A VOLCANO

Many explosive volcanoes are built up into a cone by the debris of successive eruptions. Deep beneath the volcano is a reservoir of hot, molten rock, called the magma chamber. Above the chamber is a vent leading to the neck of the volcano. This vent can become clogged because the lava may solidify. Pressure on this plug of lava builds as magma wells up into the chamber, until it is finally blasted away and the magma is forced up the vent.

Hot springs, or geysers, often occur near volcanoes

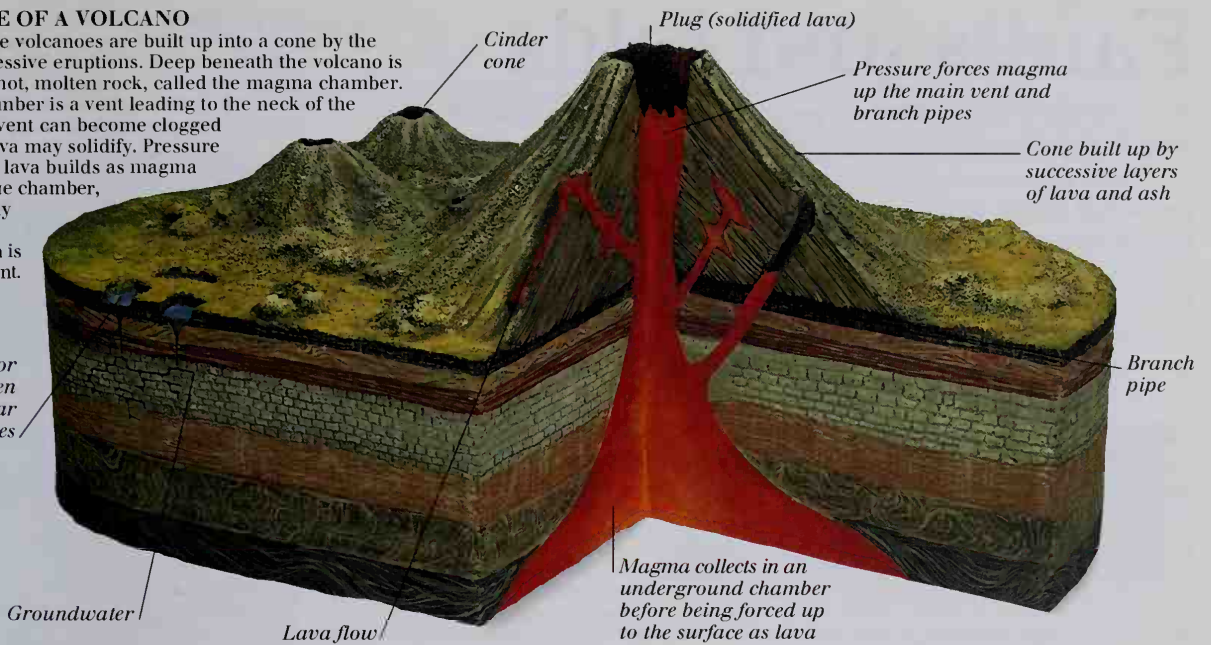

TYPES OF VOLCANOES

The shape of a volcano depends mainly on the type of lava it produces. Basaltic lava is runny because it erupts at high temperatures and contains little silica. It forms low volcanoes with gentle slopes. Acidic lava is thick because it erupts at lower temperatures and has a higher silica content. It forms steep-sided or even domed volcanoes. Many acidic lavas are explosive and so some volcanoes may be built partially of volcanic ashes.

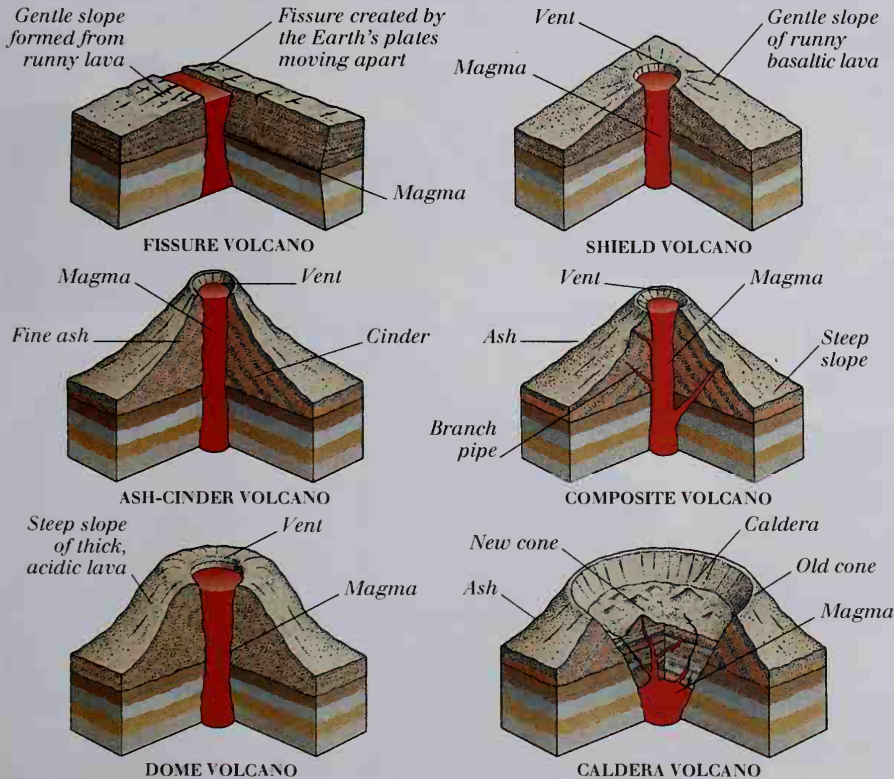

VOLCANIC FEATURES

In certain parts of the world (most notably Iceland), volcanic activity beneath the surface heats up water on and below the ground. This can create spectacular volcanic landscapes, where hot water, mud, and gases emerge from the ground.

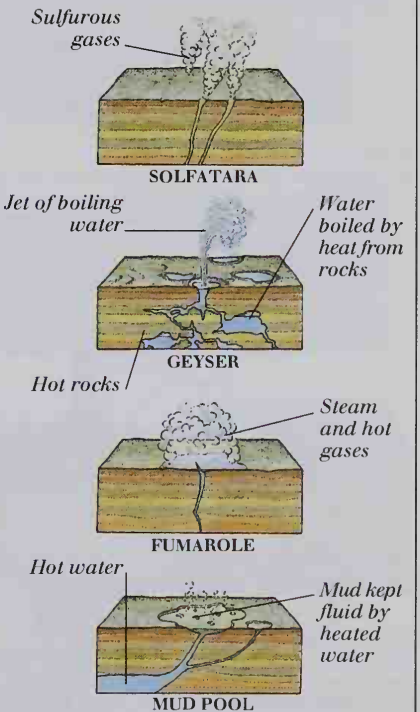

Faults and folds

AS THE TECTONIC PLATES (see pp. 272-273) that make up the Earth's surface move about, they can put rocks under huge strain. Sometimes the rocks crack, so that large blocks can slip past each other, producing faults that break up the landscape. In many cases, the plates crunch together, crumpling and twisting the rock strata into folds of all shapes and sizes, from tiny wrinkles just a few centimeters long to gigantic folds thousands of meters high. Both faulting and folding can be caused by events such as earthquakes (see pp. 274-275) or landslides, but it is tectonic-plate movement that is responsible for the most dramatic faults and folds. Tectonic-plate movement has created the faults that opened up the world's longest valley, the Great Rift Valley of East Africa. It has also folded rock layers to pile up the world's greatest mountain ranges, including the Himalayas, the Andes, the Rockies, and the Alps.

DESCRIBING A FAULT

A fault is described in terms of the geometry of its movement – its direction, angle, and extent. The surface of the fault along which the rock slips is called the fault plane. The rock will slip only a few centimeters at a time, but the cumulative effect of numerous slips over millions of years can be that blocks are moved hundreds or even thousands of meters up or down.

Dip (angle of fault plane to the horizontal)

Fault plane

Heave (sideways shift)

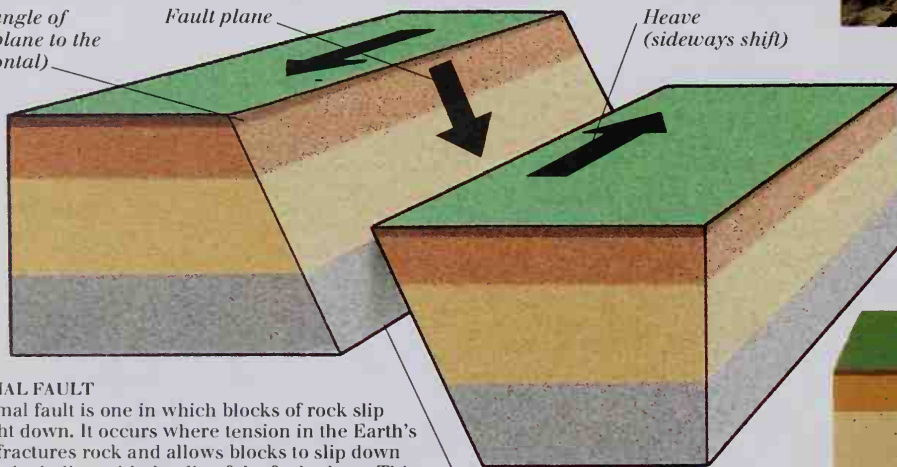

NORMAL FAULT

A normal fault is one in which blocks of rock slip straight down. It occurs where tension in the Earth's crust fractures rock and allows blocks to slip down by gravity in line with the dip of the fault plane. This is why it is also called a dip-slip fault.

Fault scarp (huge cliff exposed as graben drops)

Graben

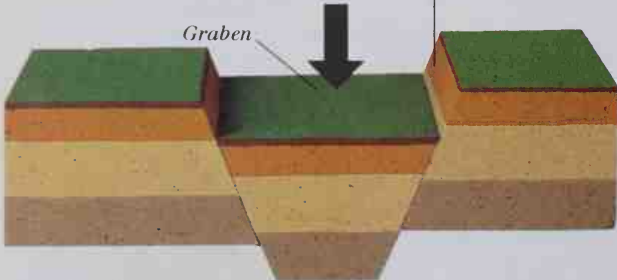

RIFT VALLEY

Rift valleys probably form when a block of rock (called a graben) drops down between two facing normal faults. These eventually form cliffs, or fault scarps. The world's most dramatic rift valley is the Great Rift Valley of East Africa.

SAN ANDREAS FAULT

Perhaps the most famous fault in the world is the San Andreas Fault in California. This is a type of wrench fault called a transcurrent fault, which occurs when two tectonic plates slip sideways past each other.



Horizontal shearing across vertical fault plane

Fault block

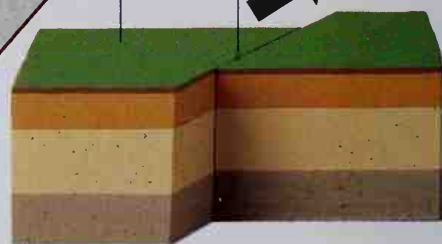

WRENCH FAULT

A wrench fault, also known as a tear fault, occurs when fault blocks move horizontally past each other, with no vertical movement.

Horst (a block of rock thrown up between normal faults)

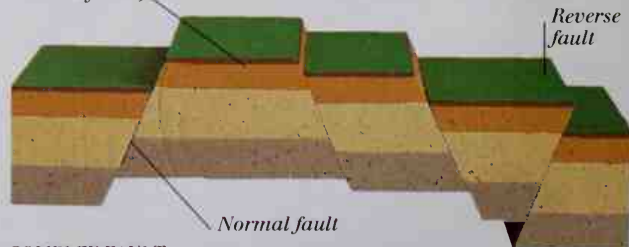

COMPLEX FAULT

Faults very rarely occur singly. Most occur in fault zones along plate margins. The result is often a series of faults, which tilt blocks in many different directions.

DESCRIBING A FOLD

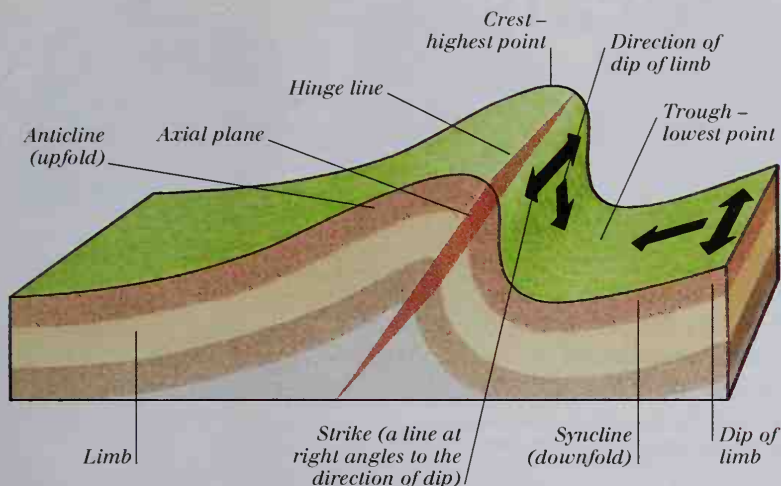

FOLD TERMINOLOGY

Geologists use many technical terms to describe the geometry and different parts of a fold. The hinge line is the "crease" of a fold. The term dip refers to the angle, in degrees, between the tilted layers of rock and the horizontal

plane. Limb is the term given to the strata (layers of rock) on either side of a fold. An anticline is an arch-shaped upfold and a syncline is a bowl-shaped downfold. The axial plane is an imaginary plane halfway between the limbs of a fold.

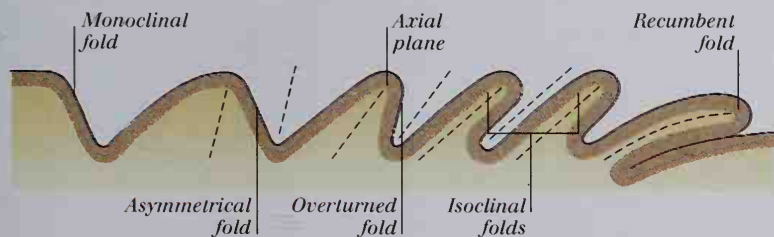

DIFFERENT TYPES OF FOLDS

Folds vary in complexity, depending on the intensity of the force causing the rock to have become deformed. As the fold becomes progressively more deformed, it may pass through the

stages from a monoclinical fold to an asymmetrical fold, then an overturned fold, and finally a recumbent fold. Isoclinal folds form after repeated tight folding produces two or more parallel folds.



MOUNTAIN BUILDING

Most of the world's great mountain ranges were built by the crumpling of rock layers as tectonic plates crashed into each other at the edge of continents. This is why the great fold-mountain systems of the world lie along the edges of colliding plates. The Andes, for example, have formed where the Nazca plate (see pp. 272-273) runs into South America, and the Himalayas rise where the Indo-Australian plate runs into Asia. This demonstration, which substitutes layers of colored clay for rock strata, shows what happens when one plate is forced below another (subducted), crumpling the crustal rocks.

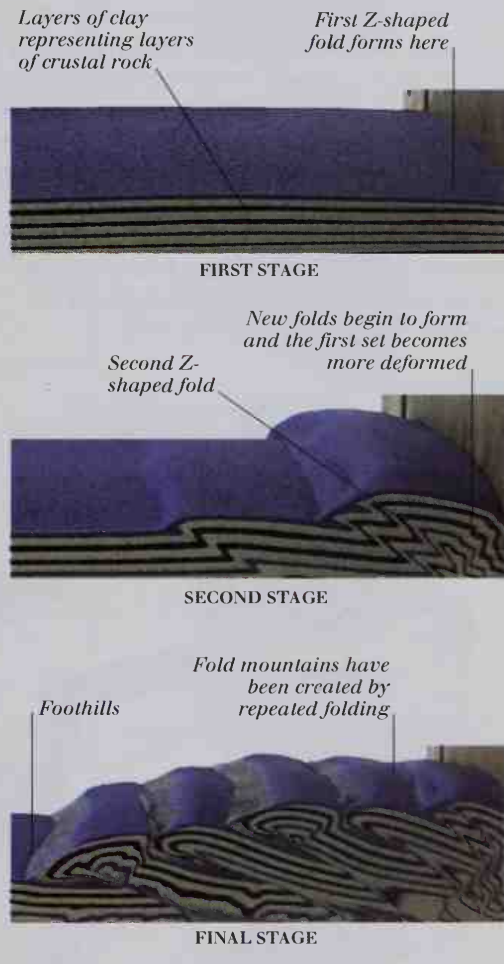

HEAVILY FOLDED ROCK

Where oceanic crust meets less dense continental crust, the oceanic crust is forced under the continental crust. This is then buckled by the impact, and fold mountains occur. Such buckling is clearly visible here in the face of the mountains of Picos de Vallibierna in the Pyrenees in northeast Spain.

Rocks and minerals

THE EARTH IS MADE UP OF ROCKS, and rocks are made up of minerals. Minerals have a specific chemical composition – sometimes a single **element**, but usually a chemical **compound** – and a unique **crystal structure** (see pp. 34-35). Mineral types may be distinguished by certain distinctive physical properties, such as hardness. Rocks are composed of one or more minerals, and the way in which the minerals are combined is a clue to the way in which rocks have been formed. Rocks are products of natural processes, which have created (and continue to change) the Earth and its surface. There are three main types of rocks, which are continuously recycled by the Earth. Igneous rocks are composed of interlocking crystals produced during the cooling of molten **magmas** derived from within the Earth. Sedimentary rocks are commonly formed through the accumulation of particles of many sizes, which have been eroded from other rocks exposed at the surface of the Earth. Metamorphic rocks are formed by the heat and pressure generated by tectonic-plate movement in the Earth's crust (see pp. 272-273).

THE ROCK CYCLE

The rock cycle starts when molten magma from the Earth's interior cools and solidifies, forming igneous rocks. Sediments may be eroded from igneous rocks exposed at the surface and then compacted and cemented to form sedimentary rocks. Metamorphism occurs when existing rocks are deformed or carried down into the Earth to be remelted, forming magmas. The cooling of these magmas starts the cycle once again.

STAGES IN THE ROCK CYCLE

Igneous rocks are often formed by the cooling of lavas that have erupted from volcanoes. These rocks are eroded through the actions of wind, water, and ice. The resulting particles are carried along in a variety of ways and are ultimately deposited by rivers as layers of sediment, which are then compacted under the weight of other layers of sediment to form sedimentary rocks. Metamorphic rocks are created through the heating and crushing of igneous and sedimentary rocks in the Earth's crust.

Glaciers erode rock and carry the rock particles to rivers

Waterfalls erode rock

Magma emerges as lava and solidifies to form rock

Volcano

Rising magma melts the surrounding rock

Heat and pressure change sedimentary rock into metamorphic rock

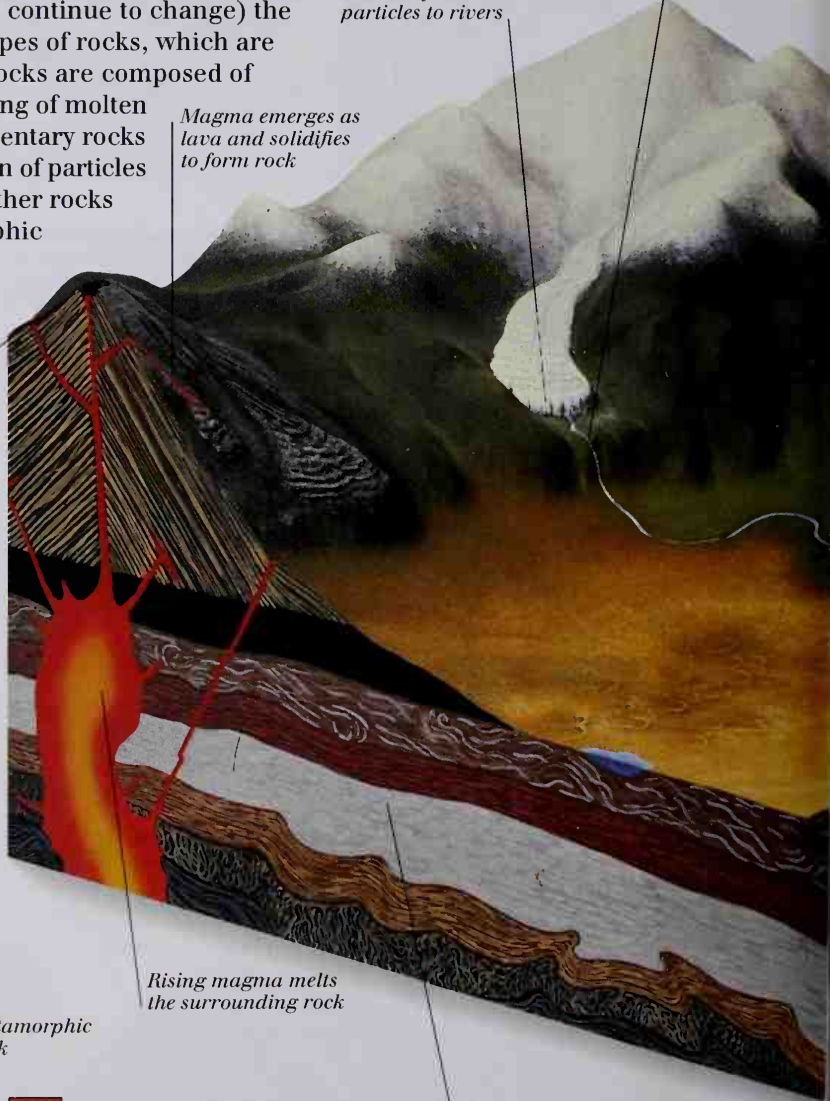
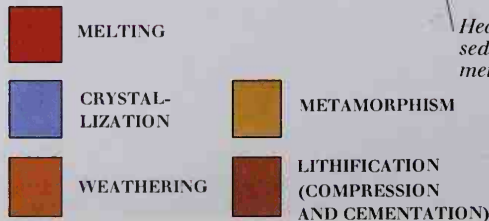
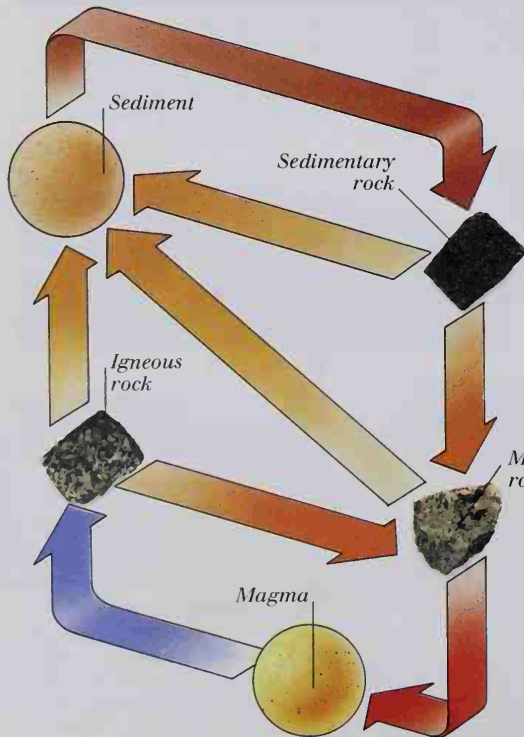

ROCK FORMATION

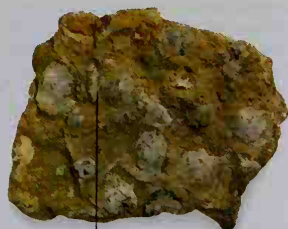
*Shelly limestone*

SEDIMENTARY ROCK

Shelly limestone is composed of one mineral - calcite. It is a sedimentary rock and is formed from the compacted shells of ancient sea creatures.

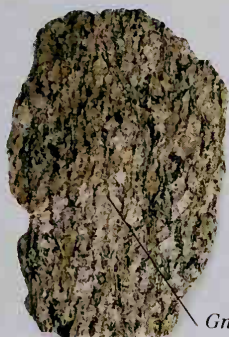
*Gneiss*

METAMORPHIC ROCK

Gneiss is a metamorphic rock found at the heart of ancient mountain belts and formed by the crushing and melting of igneous rocks, such as granite.

*Granite*

IGNEOUS ROCK

Granite is an igneous rock. It is rich in quartz and is formed by the slow cooling of silica-rich magmas from deep in the Earth's crust.

Rivers erode the valley floor, carrying particles downstream

Rock particles are carried by the wind and deposited as sand dunes

Rock particles are deposited in deltas as sediment

Heavy rock particles are deposited on the continental shelf

Light rock particles settle on the seabed as sediment

Sediments are compressed, forming layers of sedimentary rock

MOHS' SCALE OF HARDNESS

Mohs' scale of hardness, which is used to distinguish mineral types, depends simply on the ability of one mineral to scratch another. There are ten minerals in the scale. The hardest, diamond (at 10), will scratch all the other minerals on the scale. Quartz, with a hardness of 7, is fairly hard (it cannot be scratched by the steel of a knife blade). The softest minerals, talc (1) and gypsum (2), can both be scratched with a fingernail.



Talc (1)



Gypsum (2)



Calcite (5)



Fluorite (4)



Apatite (5)

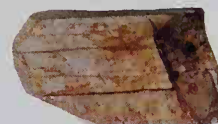

Orthoclase (6)



Quartz (7)

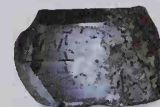

Topaz (8)



Corundum (9)



Diamond (10)

Rocky landscapes

WEATHERING AND EROSION break down the geological materials of the Earth's surface, producing a range of rocky features. Physical weathering results in the mechanical breakdown of rocks. This is achieved through the expansion and growth of crystals of salt or ice in spaces in the rock, and by the invasive growth of plant roots. Chemical weathering results in the decomposition or solution of the minerals that form the rock (see pp. 278-279). For example, limestone is commonly dissolved by acidic groundwaters. Rocks composed of several minerals may be significantly weakened by the chemical decomposition of those minerals susceptible to attack. By contrast, erosion is the physical wearing away of exposed rock or soils through the action of wind, water, and ice. Erosion is common where there is little vegetation to bind and protect the land surface, such as in deserts. Here, sand held in suspension in the air actually wears down exposed surfaces and may also be deposited in sand dunes.

FEATURES OF ROCKY LANDSCAPES

Arid landscapes are particularly susceptible to the processes of weathering and erosion, as there is little vegetation to protect the barren landscape. Physical weathering occurs as a result of the expansion and contraction of rock surfaces caused by the heat of the day and the cool of the night. This creates scree slopes, huge piles of rock fragments found at the bottom of rock faces. The abrasive action of sand carried by winds erodes weaker rocks to produce landforms such as mesas and buttes. Sands eroded from the surface may later be deposited in dunes, landforms that are continually modified by the action of the wind.

SAND BLASTING

The abrasive action of sand carried by the wind is a very important agent of erosion. Typically, most sand is carried in those winds close to the land surface. Continuous "sand blasting" will leave large rocks apparently balanced on a narrow neck.

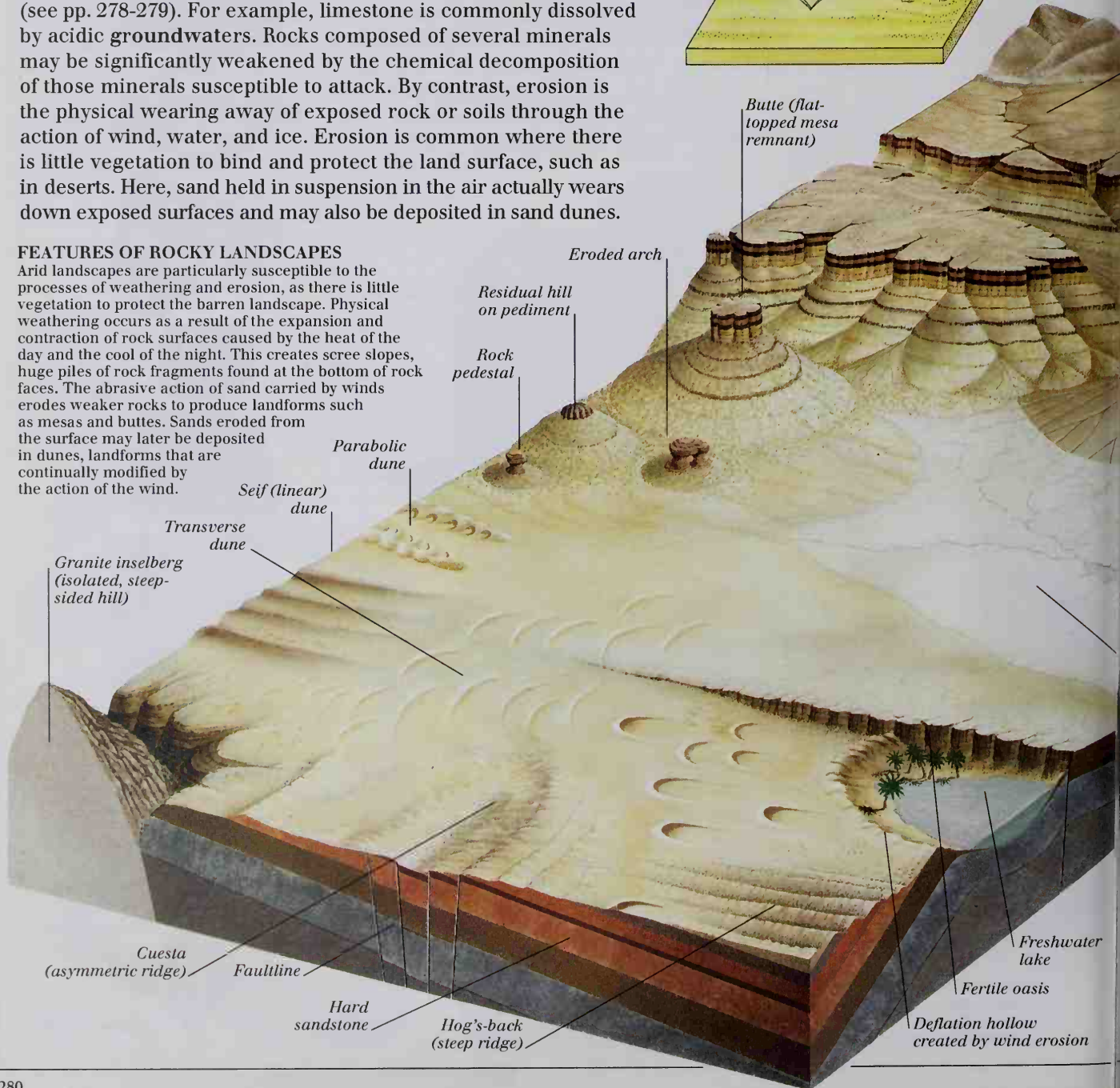
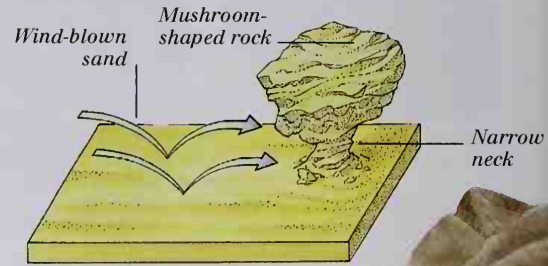

TORS

Rock outcrops that stand out on all sides from the surrounding slopes are known as tors. Tors are formed mostly in crystalline rocks with deep fractures or joints, such as granite. Intense chemical weathering along the joints attacks and breaks down some of the constituent minerals of the granite. Later, erosion strips away the weathered granite, leaving unweathered blocks protruding from the newly eroded surface. Eventually, these unweathered blocks will wear away, too.

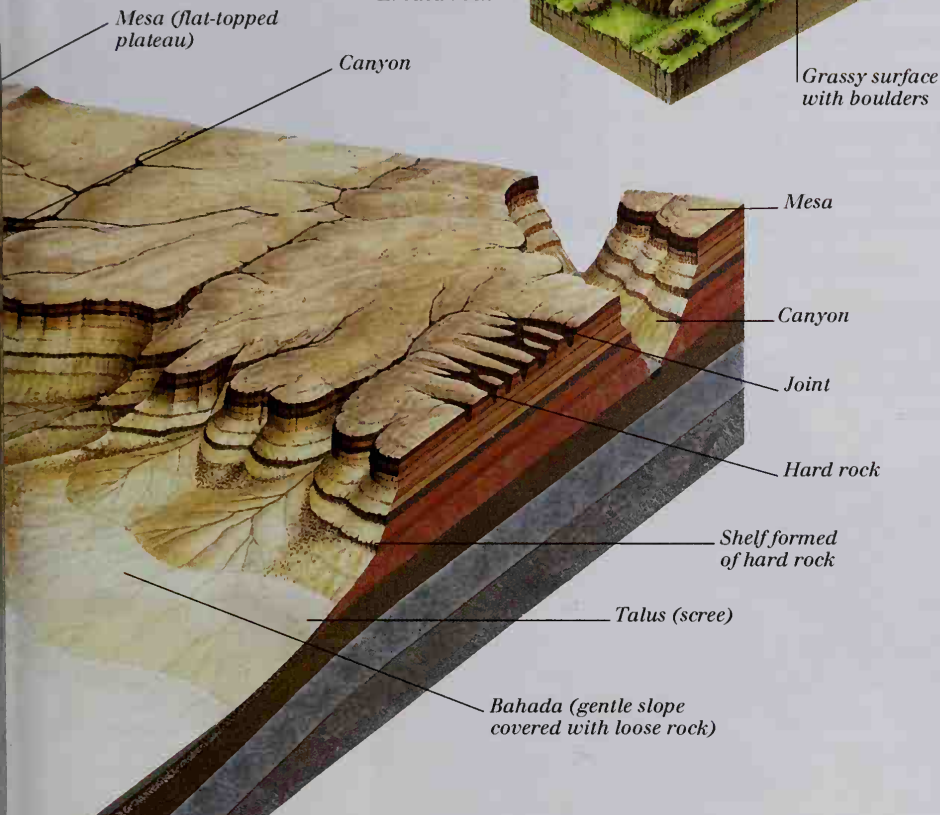
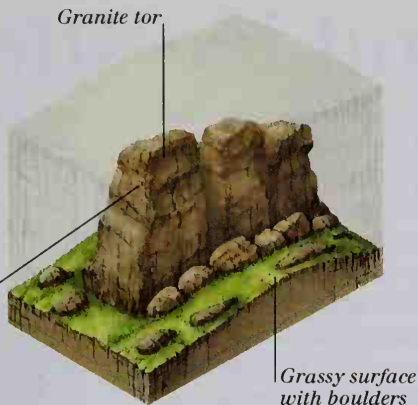

LIMESTONE CAVES

Caves tend to develop in areas where limestone is found along with a concentrated flow of acidic groundwater. This is because limestone is subject to solution by acidic groundwater, and yet is sufficiently strong to support large cavities.

Playa (dry lake bed of salt or desiccated clay)

Steam emerges over small waterfall

Pothole

Watery cavern

Sinkhole

Underground lake

Stream exits via cave mouth and flows across valley bottom

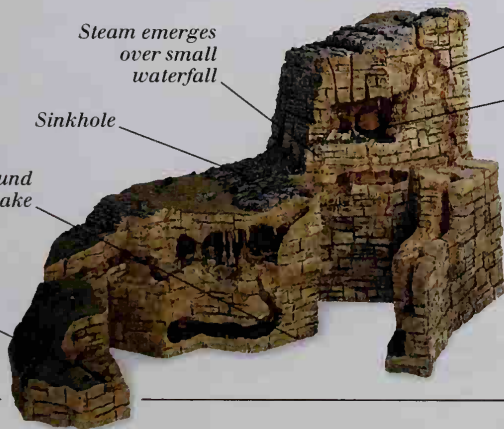

GORGE FORMATION

Deep gorges are common in limestone areas. Caves develop when the limestone is dissolved by the concentrated flow of acid-rich waters. If an entire system of interlinked caves collapses, a long, rocky-walled valley (called a gorge) is created. In some big gorges, there is no evidence of rubble from the collapsed cave roofs. Some experts think these gorges were, therefore, cut by powerful rivers when the Earth's climate was wetter than it is today.

Below the surface, the stream eats away the limestone along the fault line

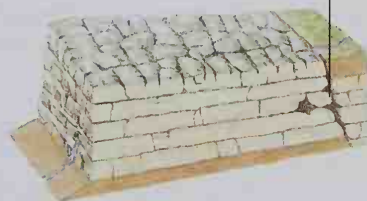

FIRST STAGE

Gradually the water opens up caves and caverns



SECOND STAGE

The water enlarges the caves and caverns, forming a huge cavity



THIRD STAGE

Eventually the roof falls in, creating a gorge

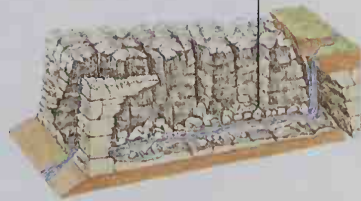

FINAL STAGE

Glaciers and ice sheets

GLACIERS ARE SLOW-MOVING masses of snow and ice. The most familiar are those in mountain valleys, developing from the accumulation of snow at the head of the valley, which is cooler because of its higher **altitude**. Here, successive layers of winter snow compress previous snowfalls to form granular ice, called **firn**, which is then finally compressed to become more dense. Such valley glaciers flow to lower altitudes at a typical rate of about two meters per day. Icebergs may be formed where the glacier flows into the sea or a lake. In high **latitudes**, close to the poles, glaciers may be extensive, covering much of the landscape. These glaciers are known as ice sheets or continental glaciers, and typical examples are seen in Antarctica and Greenland. They are domed and flow outward in all directions, replenished by fresh winter snowfalls.

RIVERS OF ICE

Glaciers often combine to form a massive, sluggish flow. For glaciers to grow, more snow must accumulate on the upper reaches than is lost by melting near the ends. This ongoing process is what drives glaciers forward.



FEATURES OF A GLACIER

Valley glaciers usually form high in the mountains from an ice-worn hollow known as a cirque, corrie, or cwm. The glaciers flow gradually down the valley to lowland areas. Variations in the rate of flow of different parts of the glacier produce deep cracks known as crevasses. As the glacier flows, it scours a new shape for the valley bottom and dumps piles of eroded sediments, called moraines.

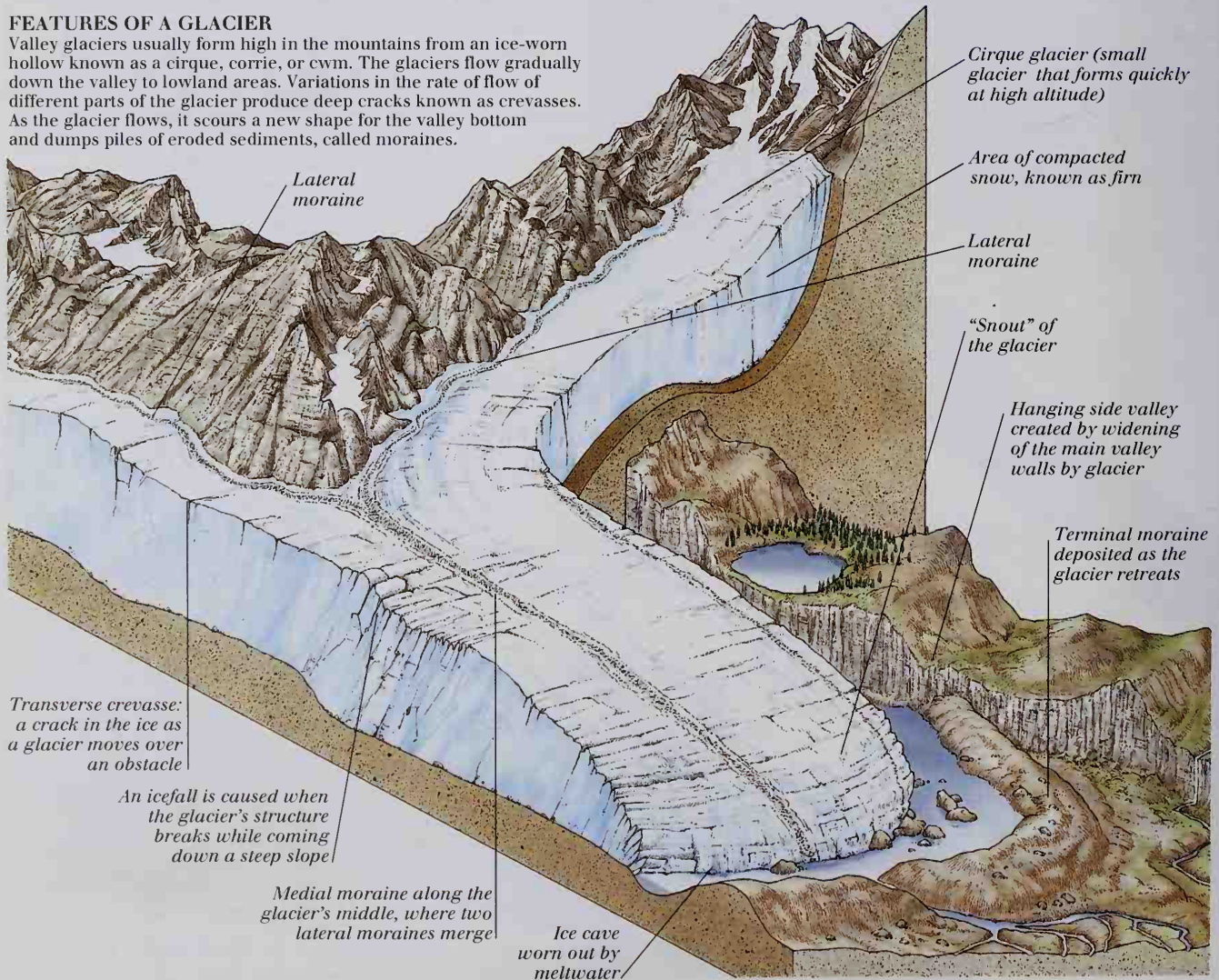

ICE SHEETS

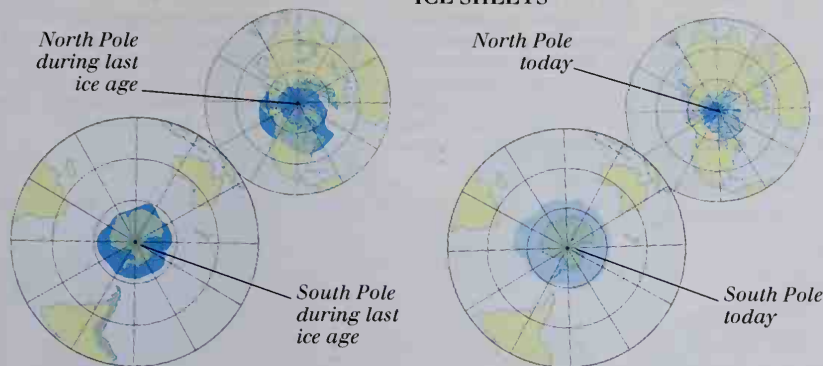

THE POLES DURING THE LAST ICE AGE
 During the last Ice Age, ice sheets extended from the polar regions to the midlatitudes, covering much of Canada and northern Europe in the northern hemisphere, and extending well beyond Antarctica in the southern hemisphere.

THE POLES TODAY
 Although we are still technically within an Ice Age, major ice sheets are limited to Antarctica, which has 90 percent of the world's ice, and Greenland. It is possible that midlatitude ice sheets may return over the next 10,000 years.

COURSE OF ICE AGES

Today's polar ice caps started forming 10 million years ago, probably because of a grouping of continents in the polar regions, which prevented the warming effect of the oceans. Current variations in the extent of the ice caps may be caused by regular variations in the Earth's axial tilt and orbital shape.

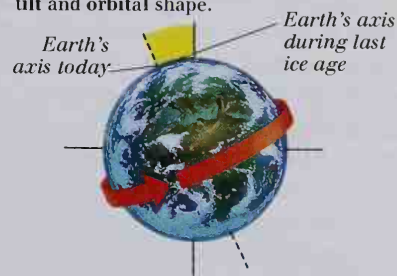

CHANGES IN THE EARTH'S AXIAL TILT

GLACIAL EROSION AND DEPOSITION

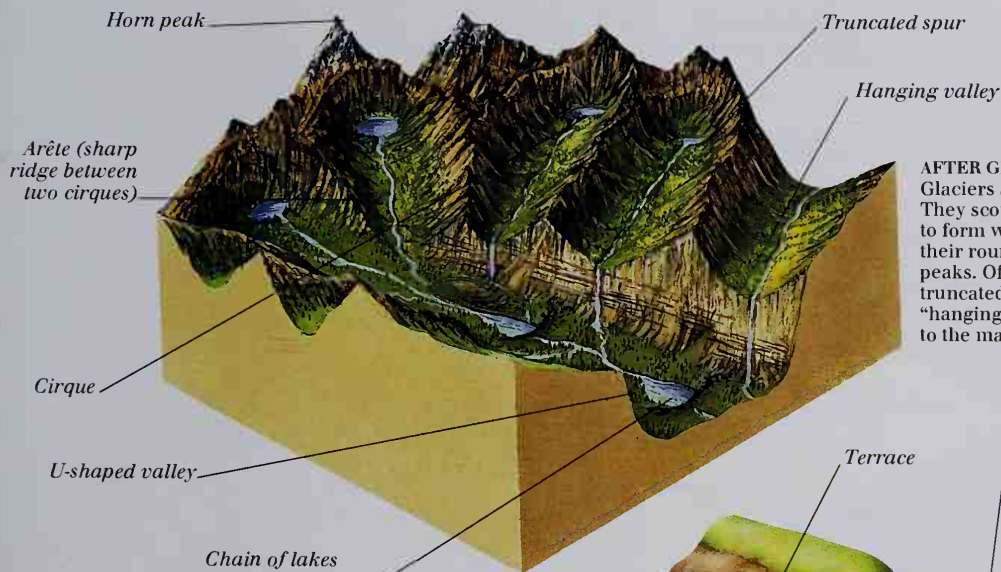

AFTER GLACIAL EROSION
 Glaciers are important agents of erosion. They scour narrow, V-shaped river valleys to form wider, U-shaped valleys, turning their rounded hilltops into ice-shattered peaks. Often, tributary valleys are truncated by the glacier to produce "hanging valleys," many with waterfalls to the main valley floor.

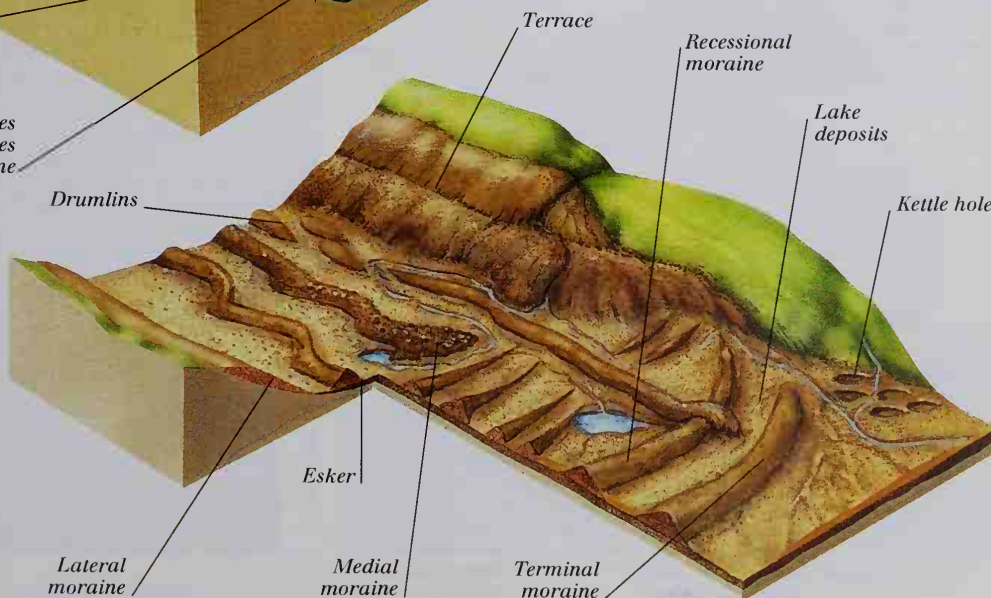

AFTER GLACIAL DEPOSITION
 Glaciers are also important agents of deposition. Sediments eroded from the landscape by the glacier are deposited in a variety of landforms. Moraines are composed of mounds of unsorted sediments that formed beneath, or at the margins of, moving glaciers; terminal moraines mark the position of the glacier "snout." Eskers are long mounds of sediment formed by the movement of meltwater streams beneath the glacier.

Rivers

RIVERS PERFORM AN IMPORTANT role in the continuous circulation of water between the land, the sea, and the atmosphere (see pp. 172-173). Wherever there is enough rain, rivers flow overland from the mountains down to the sea, or to a lake. The flow varies according to the rainfall pattern, and while some rivers are perennial (flowing year round), others, in dry areas, may be ephemeral (usually dry). Typically, a river begins as a trickle high up in the hills before growing into a rill, then a stream, and finally a river. Running water has considerable erosive power, especially when carrying sand and other debris. Because of this, the river gradually carves a channel out of the landscape, then a valley, and eventually – as it nears the sea – a broad plain. Although no one is quite sure why, all rivers have a tendency to wind, with bends in the lower reaches of the river developing into elaborate, often symmetrical, loops called meanders.

RUNNING WATER

When rain falls on the landscape, most of the water either soaks into the ground or runs off over the surface; the rest evaporates or is taken up by plants. Water that runs over the surface (overland flow) gathers into tiny rivulets and eventually into rivers. When the rain is heavy, the overland flow may flood across the land as a thin sheet of water (called sheetwash) before it gathers into streams and rivers. Some of the water that sinks into the ground (groundwater) will flow into rivers eventually too, emerging from lower down the hillside through springs.

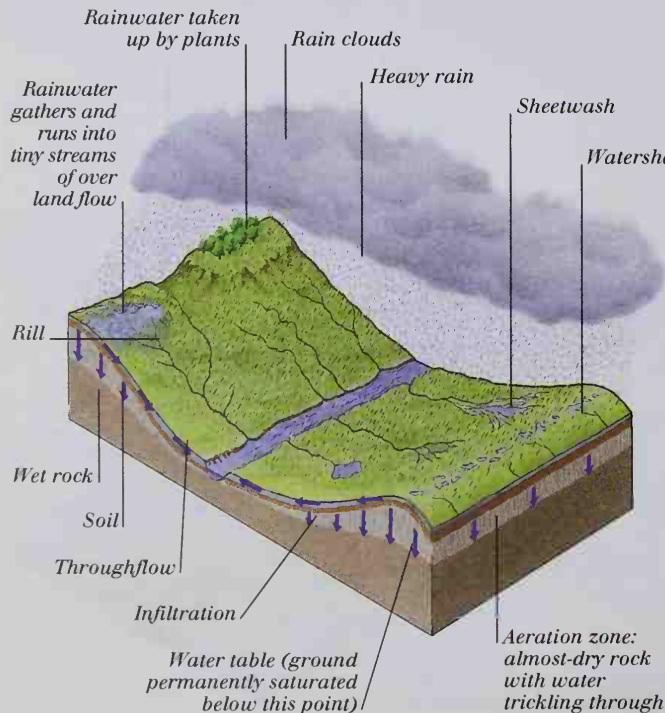

RIVER COURSE

In its upper reaches, a river is small and typically tumbles down over rapids and waterfalls between steep valley sides. Further down, the river gets wider and begins to flow more smoothly as tributaries bring in more water. Just as tributaries bring in more water, so they bring in more silt, which is washed off the land or worn away from the river banks. As it reaches the sea, it may flow into a wide tidal estuary, or split into branches and build out a delta.

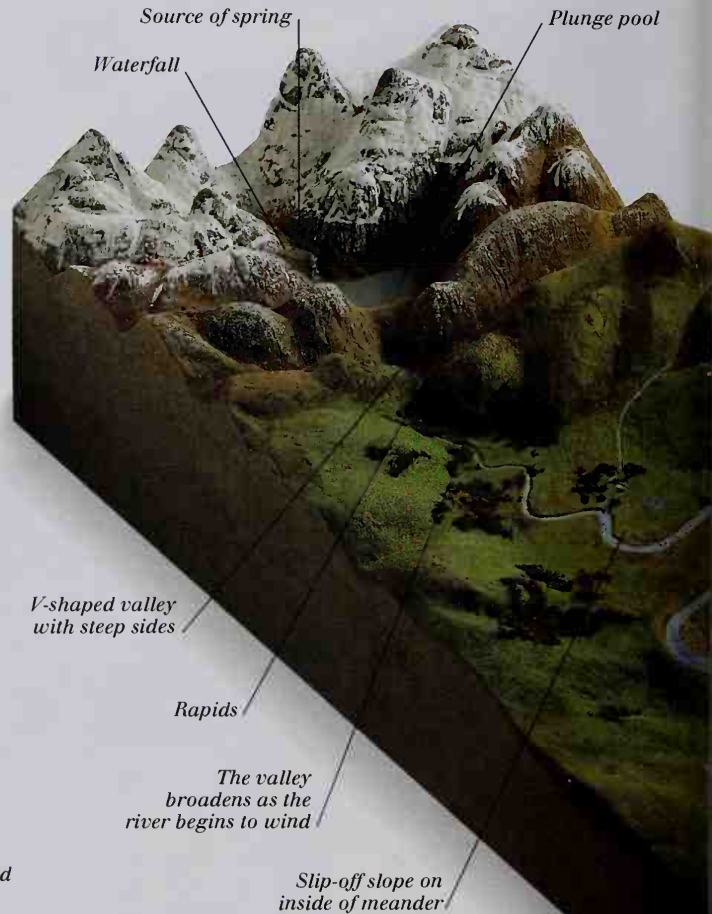

STORM HYDROGRAPH

In most damp areas, the seeping of water from underground keeps rivers flowing steadily throughout the year. But rainstorms provide short-lived peak flows as the ground becomes saturated and water flows overland into the river. Because overland flow takes time to reach the river, there is a delay, or lag, before the flow peaks. This peak can be shown on a graph called a storm hydrograph.



FORMATION OF A WATERFALL

Riverbeds usually slope gradually, but can drop suddenly in places. The place where this occurs is called a waterfall. Waterfalls are formed where a river flows from hard rock to softer, more easily eroded rock. The river cuts back through the soft rock, and water pours over the ledge of hard rock into a plunge pool below.

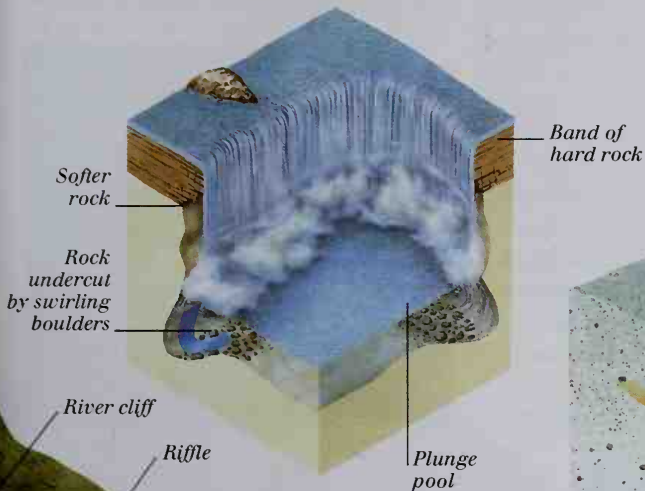

TRANSPORTATION OF LOAD

A river is capable of sweeping along considerable quantities of sediment. The greater the river's flow, the more sediment it can carry. The Yellow River in China, for example, gets its name because it carries so much silt that its waters are turned yellow. A river carries its load of sediment in three different ways: stones rolled along the riverbed (bedload); grit and sand (also called bedload) bounced along the bed (a process called saltation); and silt and other fine particles carried along in the water (suspended load). Material may also be dissolved in the water and carried in solution.

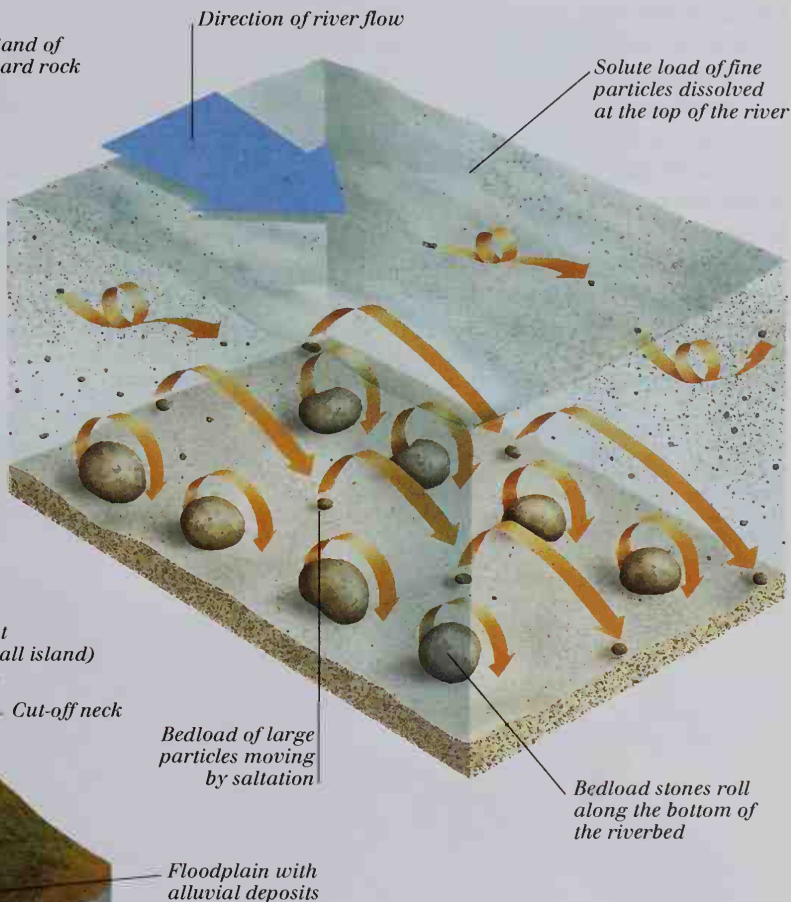

TYPES OF RIVER DELTAS

As a river meets the sea, its flow is slowed abruptly and its capacity for carrying silt diminishes. It may drop its load of sediment, and where the amount dropped exceeds the amount removed by the sea, a delta forms. The shape of the delta depends upon the interaction between the river and currents in the sea. Bird's foot deltas have a ragged coast, whereas arcuate deltas have a curved coastline. Cuspate deltas are said to be kite-shaped.



MISSISSIPPI: BIRD'S FOOT DELTA

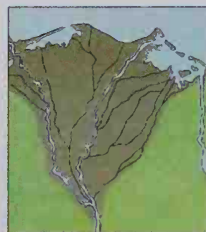

NILE: ARCULATE DELTA



NIGER: CUSPATE DELTA

Coastlines

THE BROAD REGIONS of the Earth where the land meets the sea are called coastlines. They include both the zone of shallow water, within which waves are able to move sediment, and that area of the land that is affected by waves, tides, and currents. Coastlines are a result of changes in the height of the land relative to the sea, or changes in the level of the sea relative to the land. Many were formed by changes in sea level over the last 20,000 years, since the end of the last Ice Age, when a major rise in sea levels submerged older landscapes. This produced an indented coastline of flooded valleys and created broad bays as the plains also became flooded. Many landforms are still in the process of being modified at the sea coast. There are two broad types of modification: those caused by the erosional effects of wave attack, where cliffs are undercut and collapse; and those formed by the transport and accumulation of sedimentary particles by water, building out from river mouths, or accumulating through the action of waves and currents to form mud flats or beaches.

SANDY SHORE

Constant battering by waves and seawater gives coastal regions their own unique landforms. Sand shifts, beaches are built up or washed away, cliffs crumble and fall, and even big boulders are pounded to sand as waves crash against the shore.



FEATURES OF A COASTLINE

Many coastlines were formed when sea levels rose and submerged the land. Submerged coasts are attacked by the action of the sea, which produces erosional landforms by, for example, progressively undercutting cliffs and exploiting weaknesses to form caves, arches, and then finally stacks. Long features, such as spits, form through the accumulation of sediments. Fine sediments transported by rivers accumulate in lagoons and estuaries, particularly where they are protected by beaches and spits.

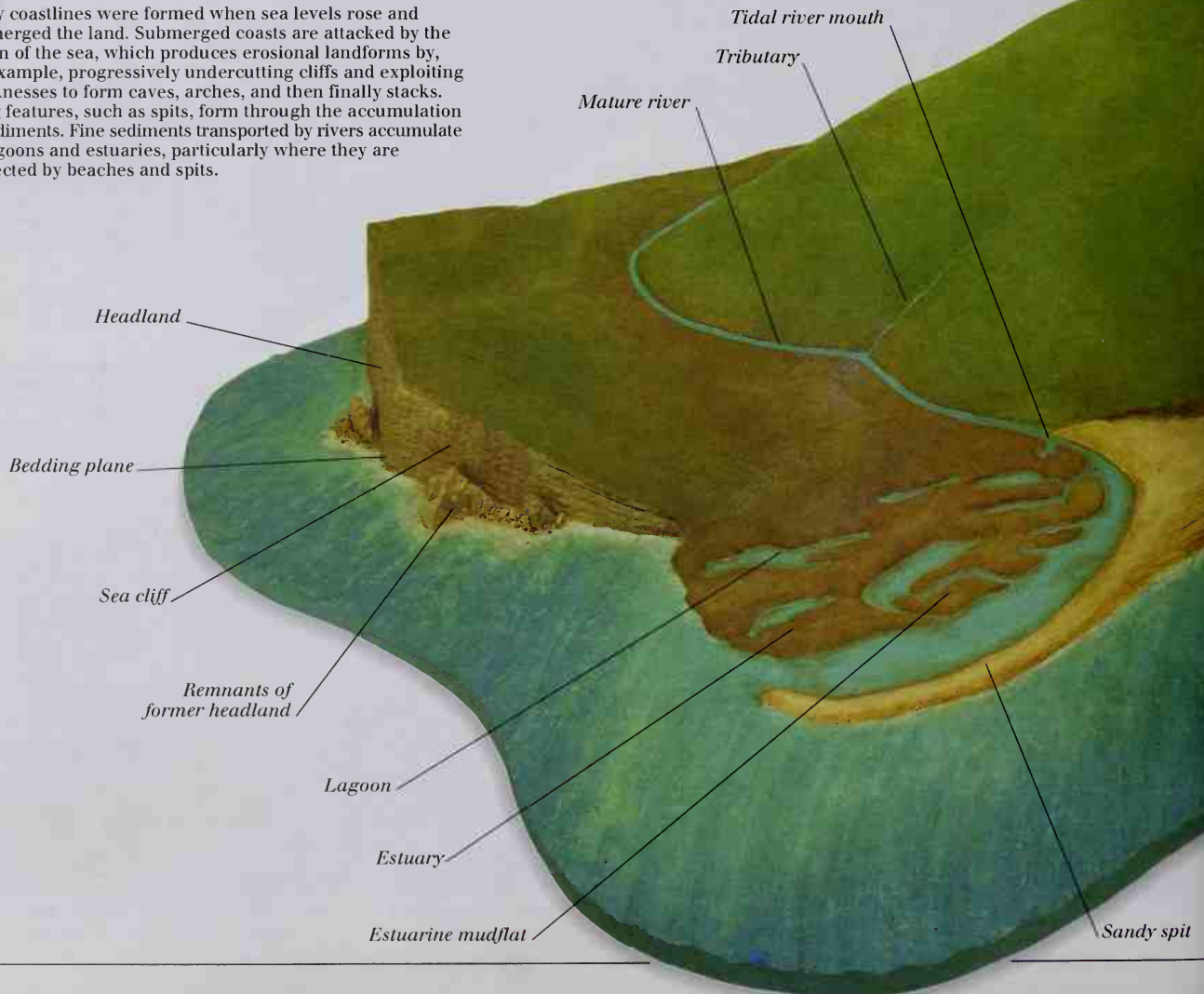

THE FORMATION OF WAVES

Waves are formed by the action of wind. The wind whips the water's surface up into ripples, which in turn build up into waves (if the wind is strong enough). As the waves travel through water, they cause it to move around in circles known as orbital paths. The size of a wave depends on the strength of the wind that formed it and the distance that the wind had to carry the wave before it reached the shore. Breaking, which occurs when the wave reaches the shore, is caused by the change in the orbital path of the water - from circular to elliptical - as the water becomes shallower.

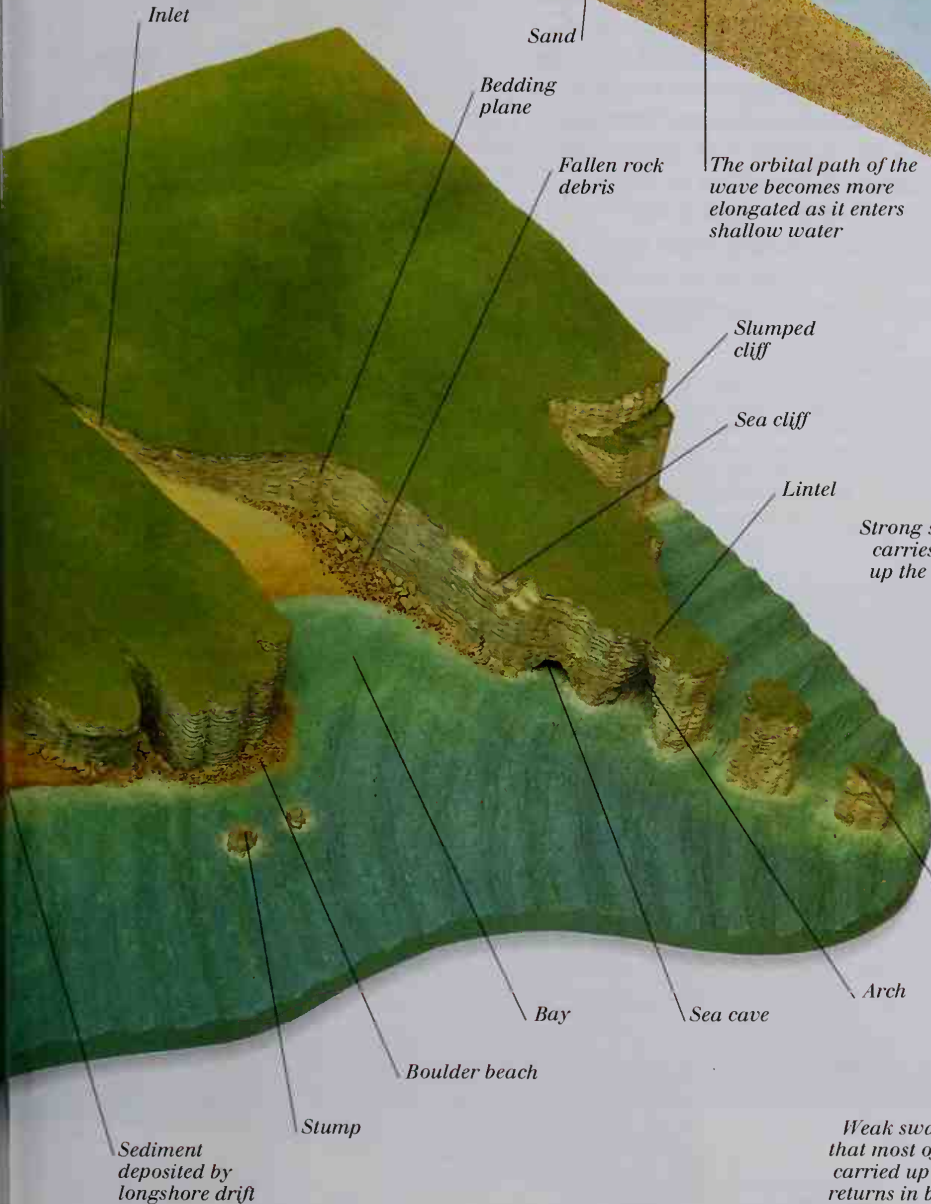
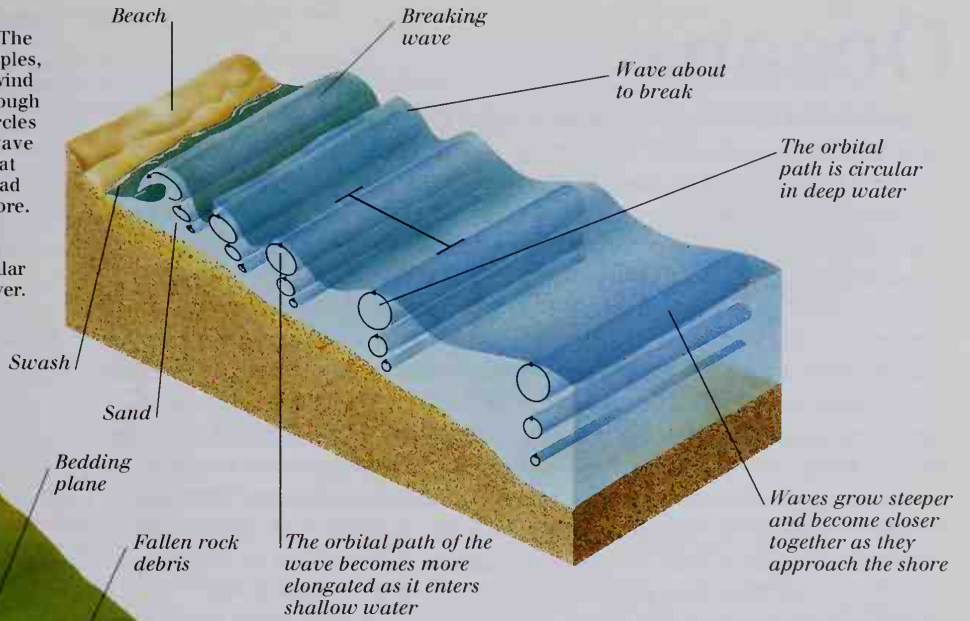

TYPES OF BREAKERS

When a wave breaks on to the shore, its energy becomes dissipated as it rushes up the beach in the swash and then falls back in the backwash. If the swash is strong enough to move sediment up the beach, the breaking wave is said to be constructive; where the swash is too weak to prevent the return of the sediment, the breaker is said to be destructive.

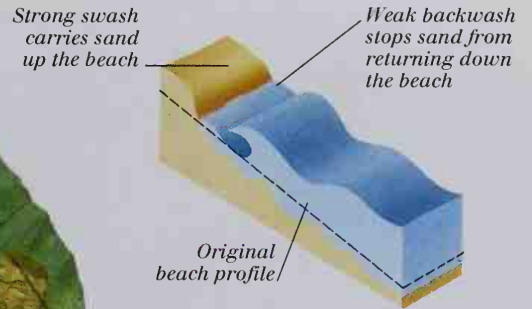

CONSTRUCTIVE BREAKER

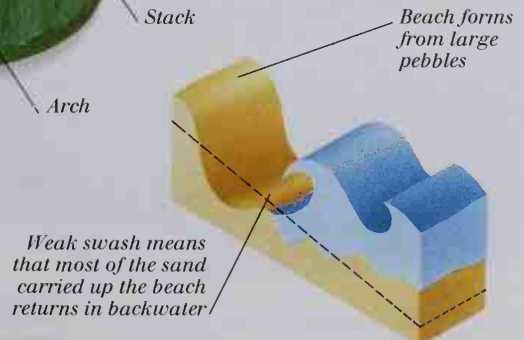

DESTRUCTIVE BREAKER

Oceans

ALTHOUGH IT MAKES UP 70 percent of the Earth's surface, the ocean floor was once as much a mystery as was the surface of the Moon. We now know that it is composed of two sections. The first is flooded continental crust, known as the continental shelf. This is rarely deeper than 140 meters. The amount of the continental shelf that is actually flooded has fluctuated through time as polar ice sheets have advanced and retreated (see pp. 282-283). There are extensive sedimentary deposits on the continental shelf. These are brought overland by rivers and deposited in the ocean. The second section of the ocean floor is the deep-ocean floor, which has a depth of about 3,800 meters. Much of the deep-ocean floor is covered by a clay, called ooze, formed from the shells of tiny sea creatures. New ocean crust is constructed at plate boundaries in mid-oceanic ridges, where magma emerges from the Earth's crust, ultimately helping to push apart plates and drive plate tectonics (see pp. 272-273). Old ocean crust is consumed in ocean trenches or **subduction zones**, where one tectonic plate dives sharply down beneath the other. Here, the descending plate melts and the resulting magma forms a chain of volcanoes known as an island arc. The circulation of ocean water occurs as a result of prevailing winds.

OCEAN FLOOR

Echo sounding and remote sensing from satellites have revealed that any deep-ocean floor is divided by a system of mountain ranges, far bigger than any on land – the mid-ocean ridge. Here magma (molten rock) wells up from the Earth's interior and solidifies,

widening the ocean floor. As the ocean floor spreads, volcanoes that have formed over hot spots in the crust move away from their magma source and become increasingly submerged and eroded. Volcanoes eroded below sea level remain as seamounts (underwater mountains).

MINERAL CONTENT OF SEAWATER

Seawater is salty because it contains minerals derived from the land over millions of years, and brought to the sea by rivers. The most common mineral is salt itself (sodium chloride), but other soluble materials are also found in seawater. Typically, seawater has a salt content of around 35 grams per liter, although this varies from one part of the ocean to another.

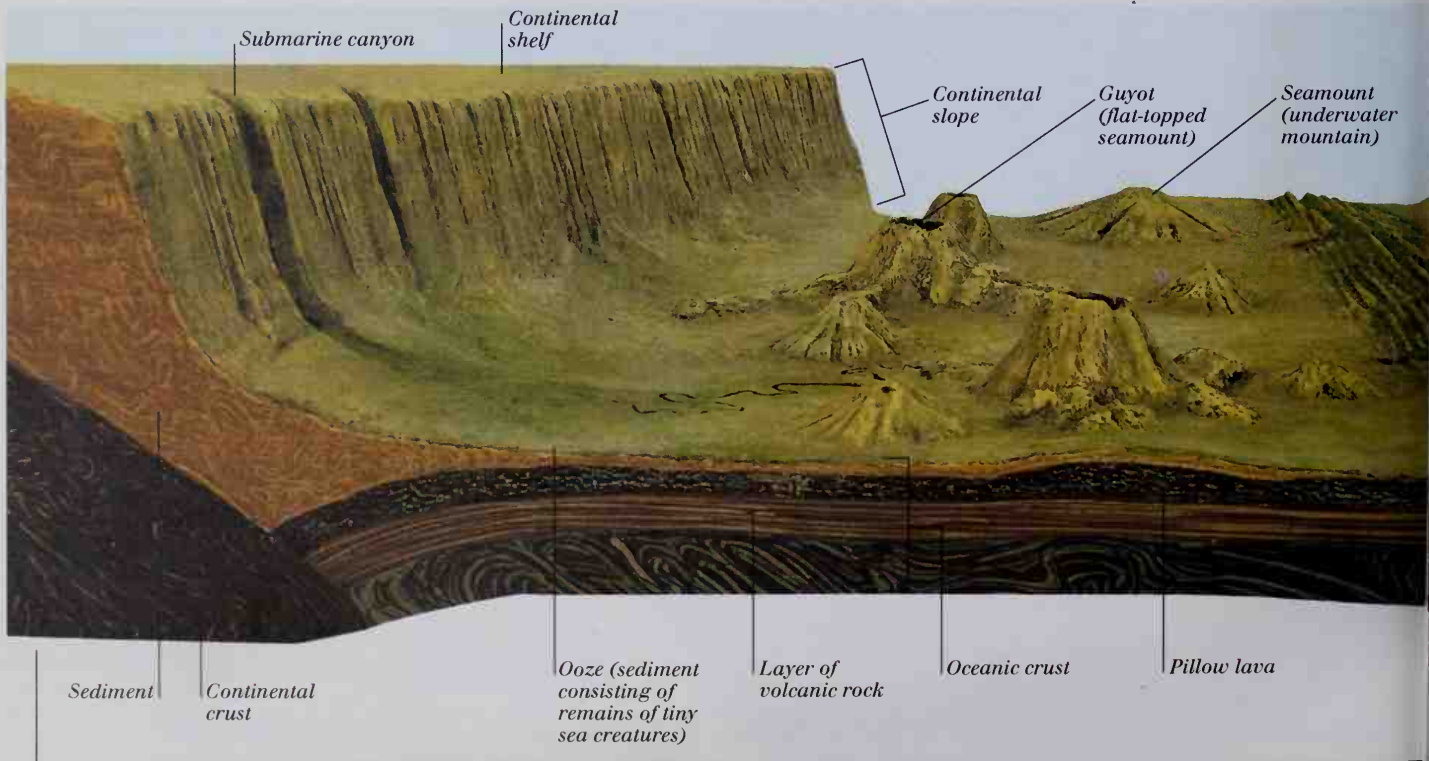
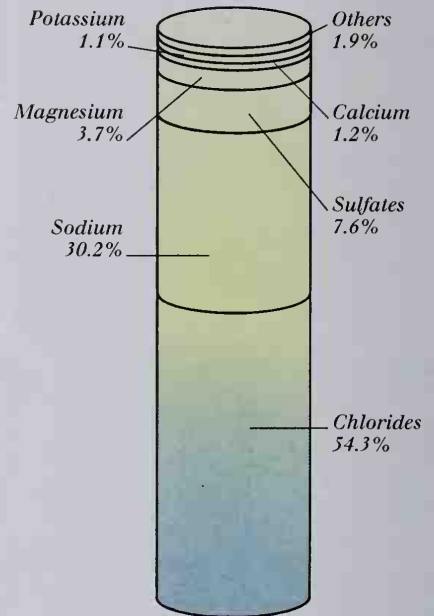

THE FORMATION OF AN ATOLL

An atoll is an island in the open ocean, composed of a circular chain of coral reefs surrounding a lagoon. The English naturalist Charles Darwin (1809-82) was the first scientist to consider in detail the way in which they are formed. He found that the reefs formed on the

margins of a submerged volcano, or seamount. As the volcano became dormant, it cooled and subsided, and its top was eroded, lowering it to sea level. Growth of the coral reefs continued as the volcano subsided, finally producing the atoll.

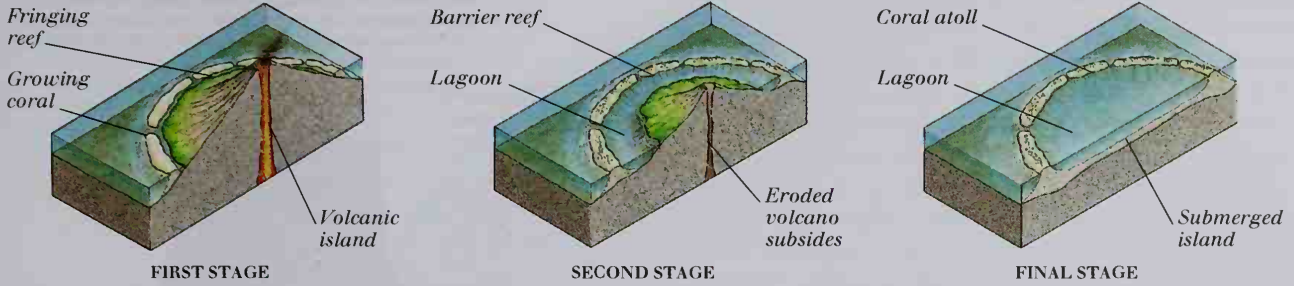

COLD-WATER UPWELLING

Ocean currents occur where the surface water flows in any one direction, driven by prevailing winds. In deep-coastal regions, prevailing winds may drive warm surface waters out to sea. The water removed in this way is then replaced by cooler waters, which well up from the deep ocean. These waters often bring rich nutrients with them and affect the local climate.

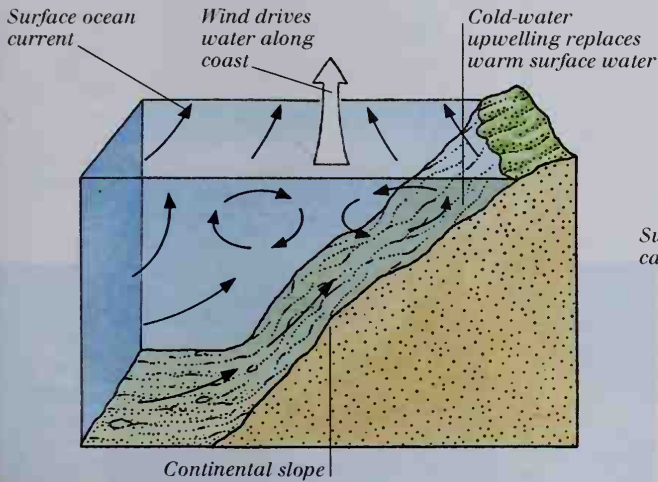

SEA CURRENTS

Prevailing winds blowing across the ocean surface produce currents in the upper layers of the water to a depth of about 100 meters. The Earth's rotation causes a deflection in these currents, usually at right angles to the direction of the wind. This is known as the Coriolis force, and is named after the French physicist Gaspard Coriolis (1792-1845). The currents are deflected to the right in the northern hemisphere and to the left in the southern hemisphere.

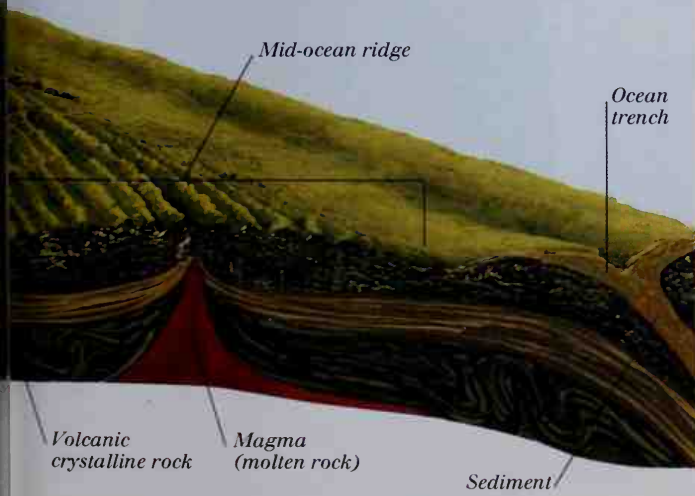
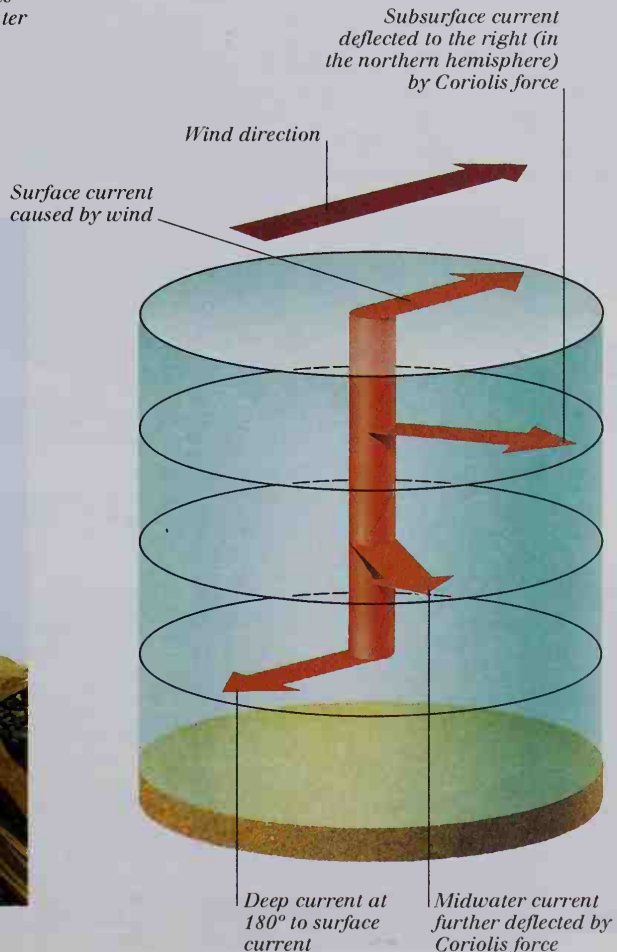

The atmosphere

THE ATMOSPHERE is an odorless, tasteless, colorless mixture of gases. It may seem as if it is nothing but thin air, but it actually has a surprisingly complex structure, with several distinct layers or spheres, each with its own particular characteristics – from the turbulent troposphere just above the ground to the rarefied exosphere, which merges into the black nothingness of space. The atmosphere is about 700 km deep, but there is no real boundary – it simply fades away into space as the air becomes thinner and light gas molecules such as hydrogen and helium float away. In comparative terms, the atmosphere is no thicker on the Earth than is the peel on an apple, but without it the Earth would be as inhospitable as the Moon (see pp. 310-311). The atmosphere gives us air to breathe and water to drink; it keeps us warm; it protects us from the Sun's harmful rays; and shields us from meteorites (see pp. 322-323).

THE FATE OF SOLAR RADIATION

Less than 47 percent of the energy from the Sun reaches the ground; the remaining 55 percent or so is absorbed by the atmosphere or is reflected back into space. Water vapor, carbon dioxide, and other gases in the atmosphere act like the panes of glass in a greenhouse, trapping some of the energy that reaches the ground as heat and preventing it from being lost into space. This heat energy is then spread through the air by a process called convection.

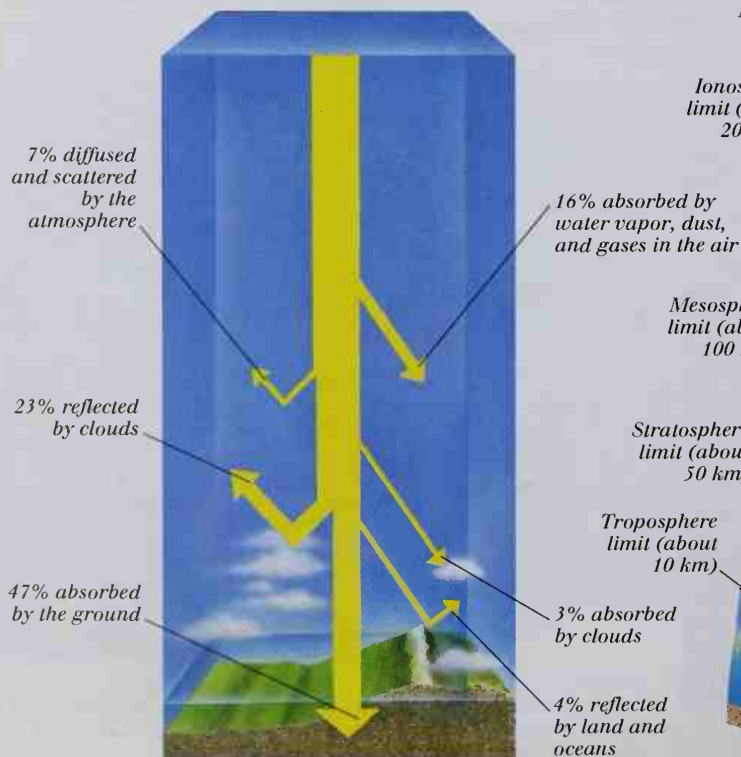

LAYERS OF THE ATMOSPHERE

The atmosphere is divided into layers according to temperature variation and height. In the troposphere, which is the lowest layer, the temperature decreases with height. In the stratosphere the temperature increases with height. The mesosphere lies above the stratosphere and is a thin layer of gases where the temperature drops rapidly. Gases within the final three layers of the atmosphere – the ionosphere, thermosphere, and exosphere – get progressively thinner.

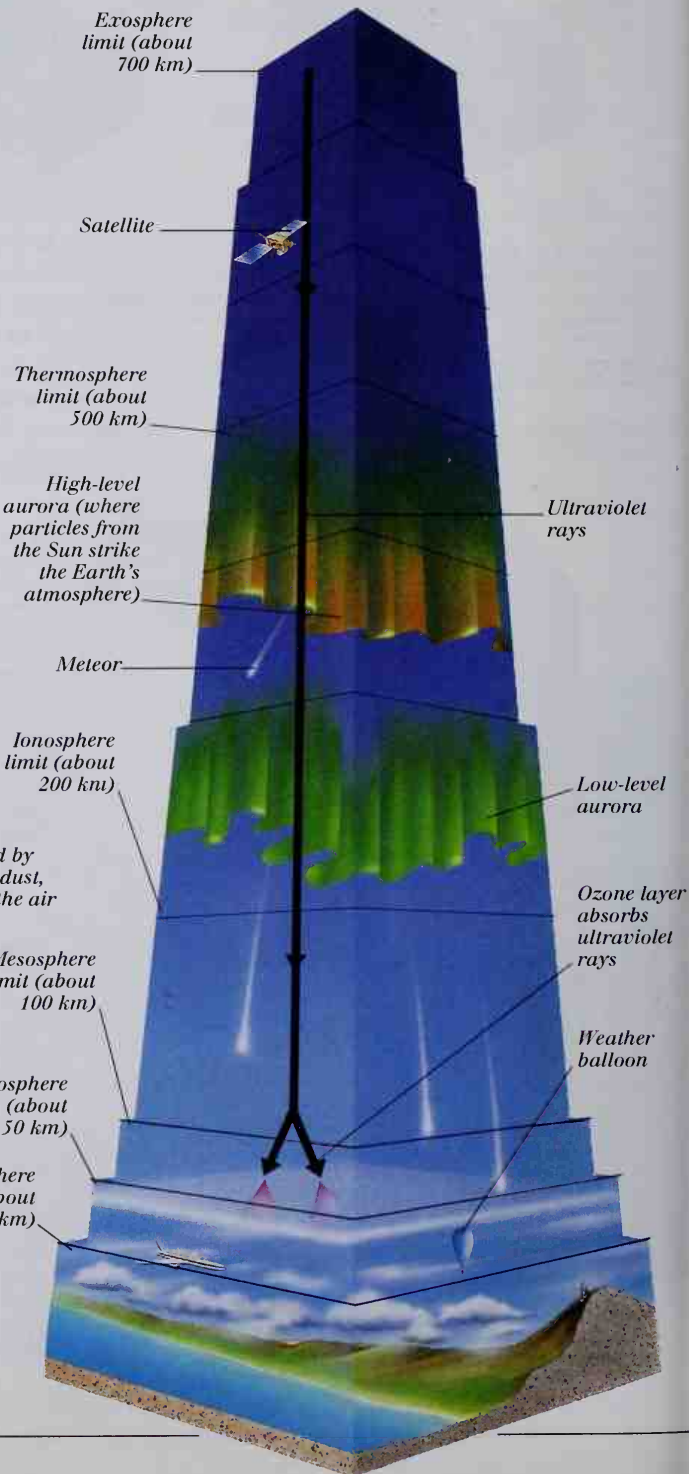

GLOBAL WIND CIRCULATION

The massive difference in the amount of the Sun's warmth received by the tropics and the poles creates a very strong pattern of prevailing winds around the world. Because hot air rises at the equator (where the Sun's warmth is greatest) and sinks at the poles, there is a constant movement of air at ground level from the poles to the equator and a reverse movement higher in the atmosphere. This general circulation is split into three zones or "cells," each with its own wind pattern: dry, northeasterly and southeasterly trade winds in the tropics; warm, moist westerlies in the midlatitudes; and cold, polar easterlies in the polar regions.

WIND PATTERNS

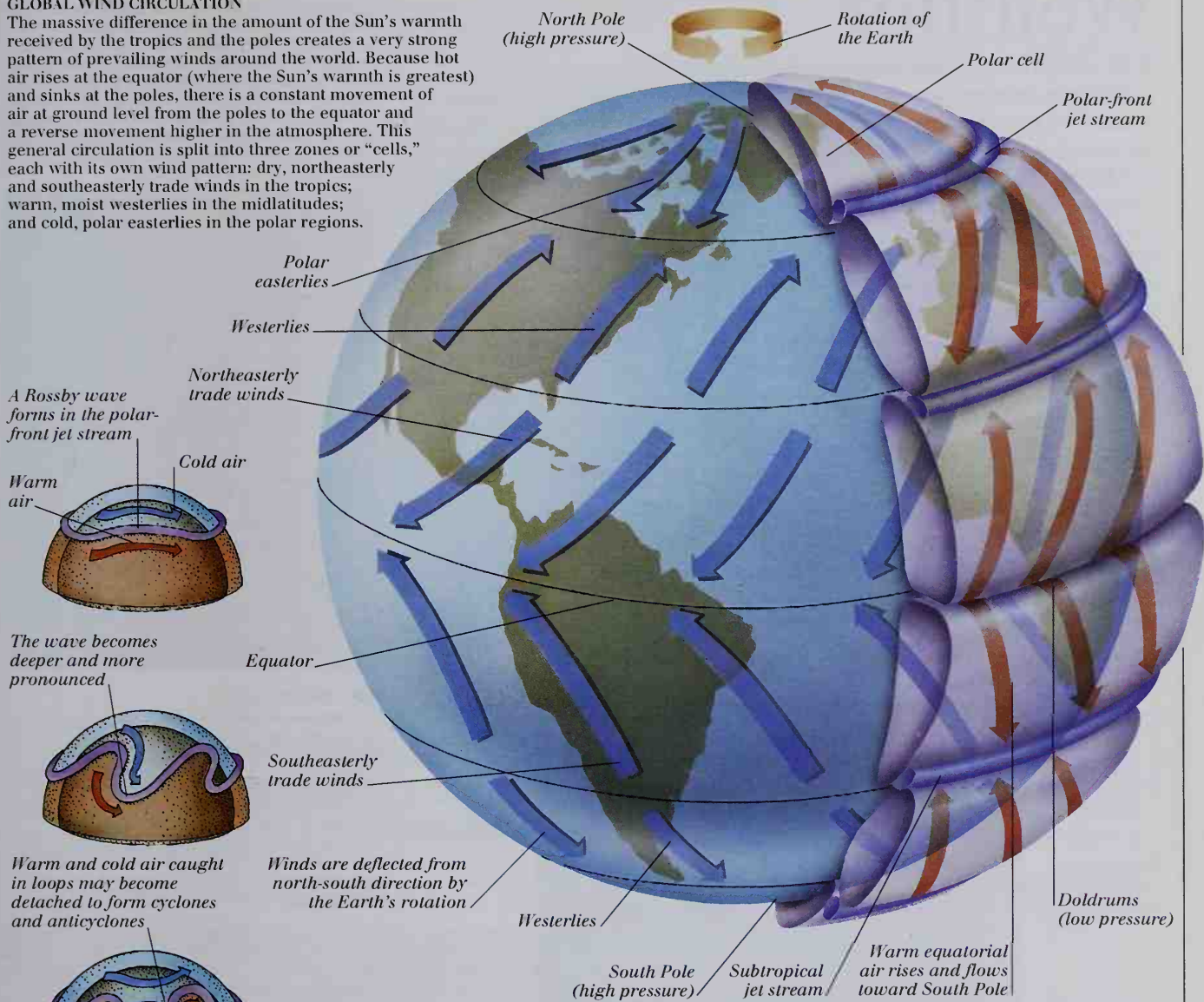

A Rossby wave forms in the polar-front jet stream

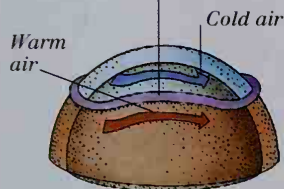

The wave becomes deeper and more pronounced

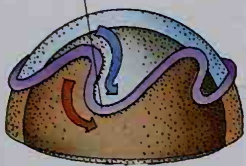

Warm and cold air caught in loops may become detached to form cyclones and anticyclones

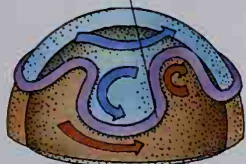

ROSSBY WAVES

In addition to the low-altitude circulation cells that are part of the large-scale pattern of air circulation, there are also high-speed, high-altitude winds in the atmosphere. Included among these is the polar-front jet stream, which meanders around the world in four to six giant waves, each about 2,000 km long. These waves are called Rossby waves, and are caused by the Coriolis effect (the deflection of winds by the Earth's rotation). They have no fixed positions, but probably snake along the polar front, where the confrontation between warm, tropical westerly winds and cold, polar easterly winds causes continual storms.

JET STREAM

Jet streams are narrow bands of high-altitude westerly winds that were discovered by the Swedish-American meteorologist Carl-Gustaf Rossby (1898-1957). They roar around the atmosphere at speeds of up to 370 kph, driving the world's weather systems. The steadiest jet streams are the subtropical jet streams (shown right, over Egypt and the Red Sea), which lie between 20° and 30° North, and 20° and 30° South. There is also a polar-front jet stream along the polar front, an Arctic jet stream, and a polar-night jet stream, which blows only in winter during the long polar night.



Weather

THE LOWEST LAYER of the atmosphere – the troposphere – is in continuous motion (see pp. 290-291), driven by pressure differences created by unequal distribution of the Sun's heat between the poles and the equator. This continuous motion causes the differences in weather conditions that occur across the globe. Weather conditions are usually assessed in terms of temperature, wind, cloud cover, and precipitation, such as rain or snow. The most important atmospheric changes influencing weather are: the way the atmosphere moves, controlling wind patterns; its temperature, helping define cold spells and warm periods; and its moisture content, influencing cloud formation and precipitation. It is the forecaster's job to record these changes and predict their effect on the weather. For example, clear weather is usually associated with high-pressure zones, where air is sinking. In contrast, cloudy, wet, and changeable weather is usually found in low-pressure zones, which have rising air. An extreme form of low-pressure area is a hurricane, which brings with it strong winds and torrential rains.

TYPES OF CLOUD

Clouds form when water vapor in the air is lifted high into the sky so that it cools down and condenses, to form either water droplets or tiny ice crystals. The ratio of ice crystals to water drops depends on how high the cloud is and how cold the air is. The highest clouds are generally all composed of ice crystals, while the lowest are composed mostly of water drops. Clouds take many forms, but there are three basic types – cirrus (wispy clouds of ice crystals), cumulus (fluffy white clouds), and stratus (vast, layered clouds). These three basic types are broken down further into 10 categories according to the altitudes at which they occur.

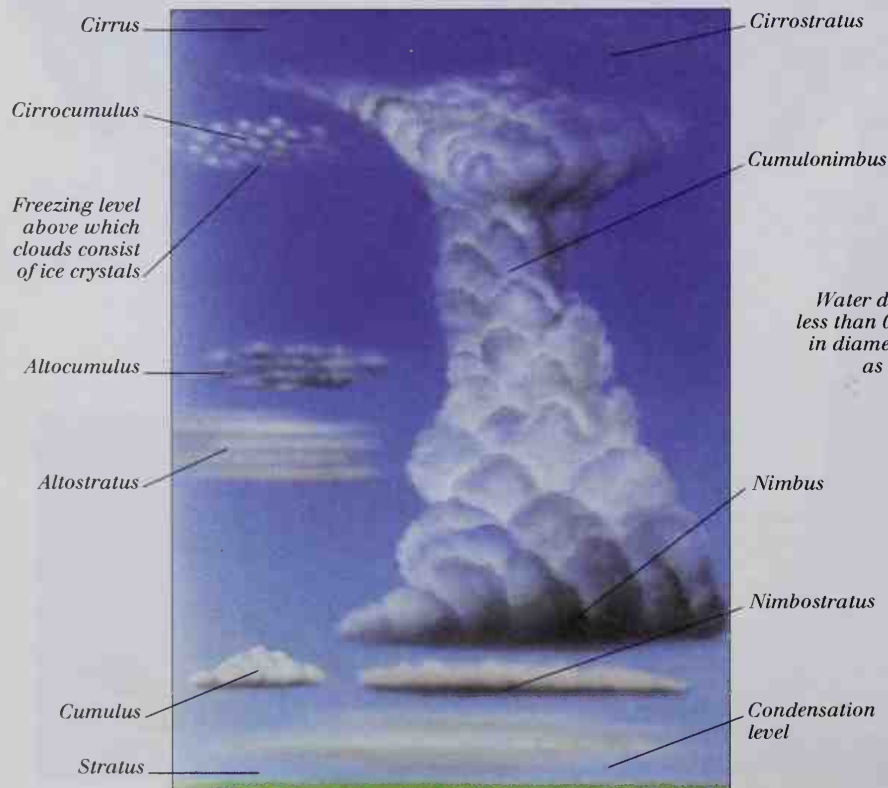

LIGHTNING

Lightning is created by violent air currents inside thunderclouds, which hurl cloud particles together, making them electrically charged. Heavier, negatively charged particles sink in the cloud and positively charged particles rise. This creates a charge difference, which is equalized by a bolt of lightning flashing either within the cloud (sheet lightning) or between the cloudbase and the positively charged ground (fork lightning).

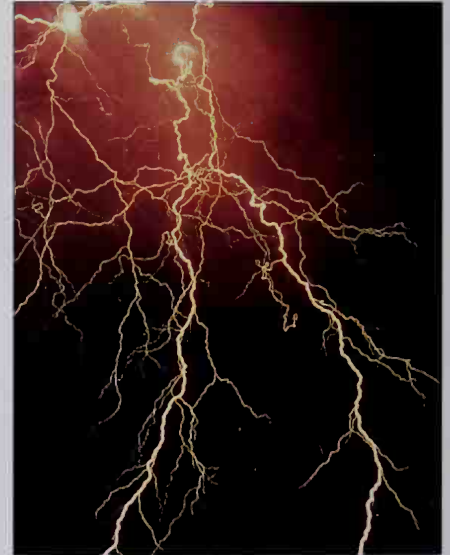

PRECIPITATION

Precipitation is a blanket term used to describe rain, snow, hail, and every other form of moisture that falls from clouds. Clouds are made of drops of water plus ice crystals that are small enough and light enough to float in air. Rain starts when a cloud is disturbed – perhaps by a strong updraft – causing the water drops to grow too large and too heavy to float in the air any longer. Raindrops grow in various ways, including colliding with other drops and growing into ice crystals.

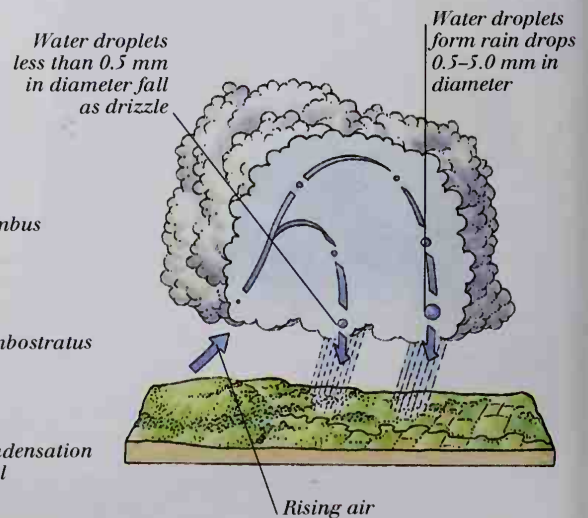

STRUCTURE OF A HURRICANE

Hurricanes, which are also known as willy-willies, tropical cyclones, and typhoons, are violent tropical storms. They begin life as clusters of thunderstorms over warm seas. Massive banks of clouds form in a ring as winds begin to spiral around the storm center with gathering force, eventually merging into a single spiral. The very center of the storm, however, is a calm "eye." As the storm develops, it drives across the ocean, bringing torrential rain and winds that gust up to 360 kilometers per hour.

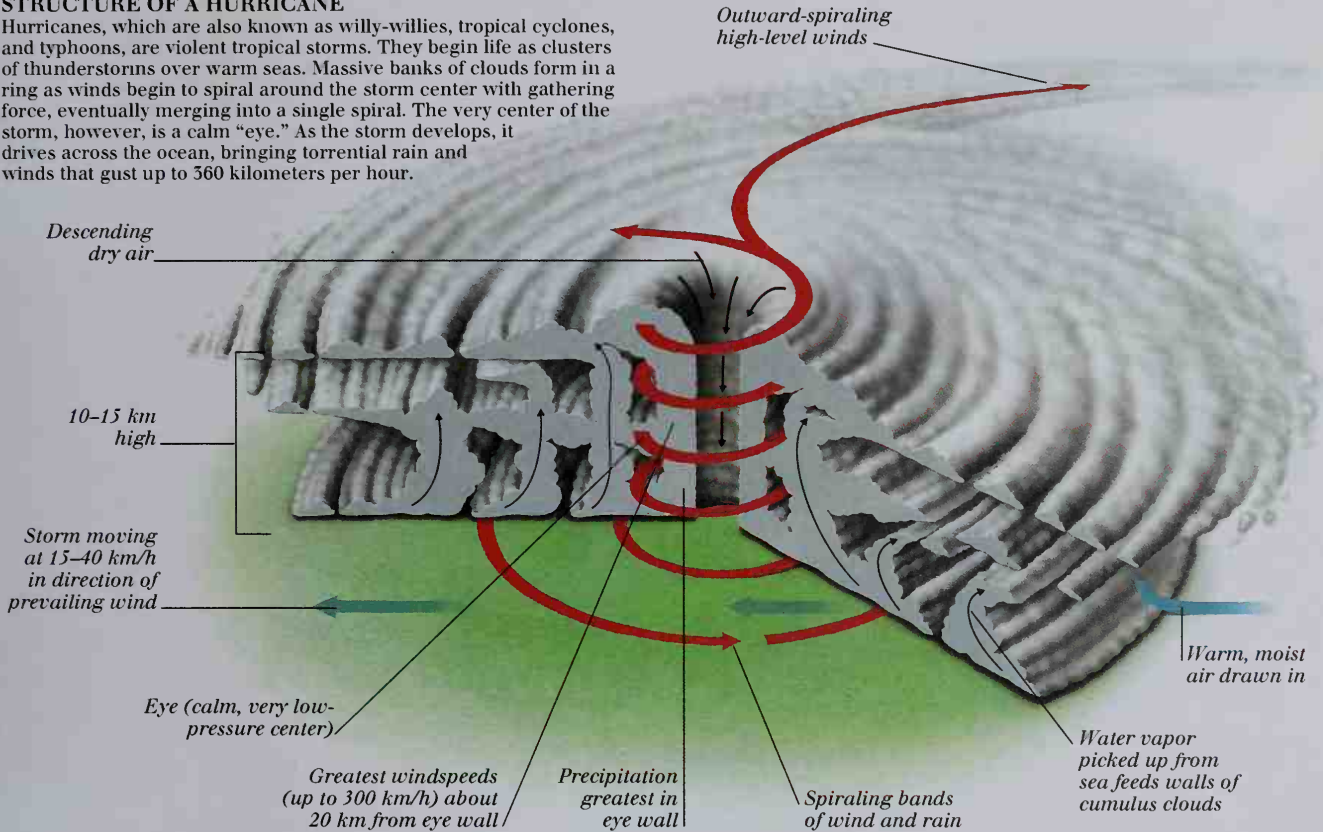

WEATHER MAP

Weather maps are a way of displaying the weather data from numerous weather stations in a single, graphic form. The contour lines on the map are isobars, lines joining points where the barometric (air) pressure is equal. Thick lines with either bumps (warm fronts) or spikes (cold fronts) indicate where air masses meet and storms are concentrated. Key-shaped symbols mark weather stations and indicate wind strength and direction.

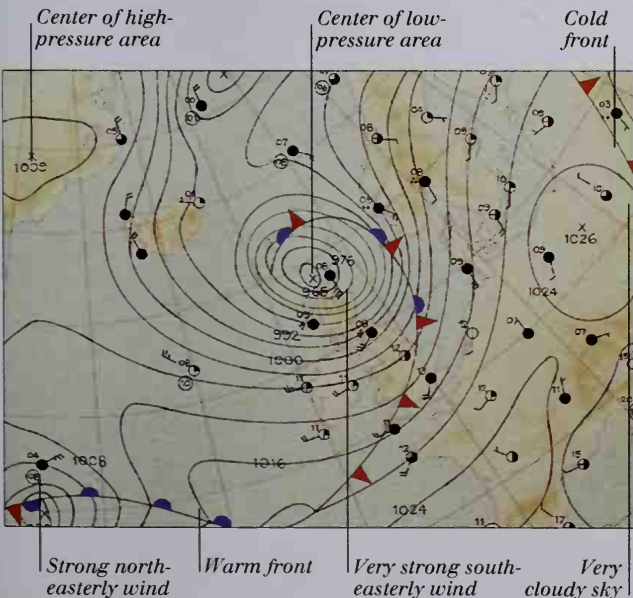

EVOLVING FRONTS



Warm air Cold air

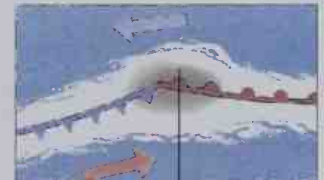

Depression caused by warm air

AIR MASSES COLLIDE
Cold, polar air (spikes) and warm, tropical air (bumps) collide at the polar front.

PUSH AND BULGE
A depression forms where the warm air bulges into the cold air at the polar front.

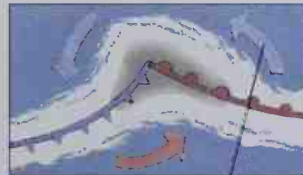

Spiralling air

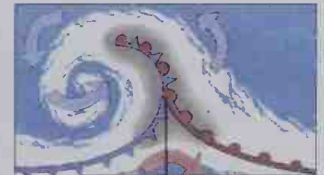

Cold and warm fronts merge

SPLITTING IN TWO
Cold air chases the warm air in a spiral, causing the polar front to split into two arms.

OCCLUDED FRONT
The cold air catches up and merges with the warm air, forming an occluded front.



Crescents of Neptune and one of its moons - Triton, taken by Voyager 2

ASTRONOMY AND ASTROPHYSICS

DISCOVERING ASTRONOMY AND ASTROPHYSICS.....	296
TELESCOPES.....	298
OBSERVATIONAL TECHNIQUES	300
SPACE PROBES.....	302
THE SOLAR SYSTEM	304
THE SUN	306
PLANETARY SCIENCE	308
THE MOON.....	310
MERCURY AND VENUS	312
MARS	314
JUPITER	316
SATURN AND URANUS	318
NEPTUNE AND PLUTO	320
COMETS, ASTEROIDS, AND METEOROIDS	322
STARS	324
STELLAR LIFE CYCLES	326
GALAXIES	328
NEUTRON STARS AND BLACK HOLES.....	330
COSMOLOGY.....	332

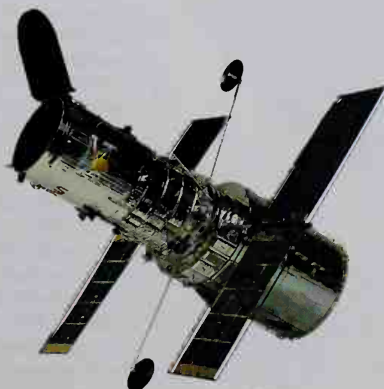

Discovering astronomy and astrophysics

THE SCOPE OF ASTRONOMY is vast. It is the most ancient of sciences – people have always studied the sky – and includes the origin and evolution of the universe, as well as the position, motion, and behavior of all the objects in space. Astrophysics is a modern branch of astronomy that deals with the physics behind cosmic processes, such as the formation and evolution of stars and galaxies.

ANCIENT ASTRONOMY

Early attempts at timekeeping made use of observations of the position of the Sun during the day and the stars at night. Before long, the Sun and stars became aids to navigation. Systematic study of the sky seems to have begun with the ancient Babylonians, who identified several constellations as early as 3000 bc. Many other early civilizations studied the sky, producing star maps that were illustrated with drawings of mythological creatures. This suggests that they had developed mystical beliefs about the stars that are no longer held.

ASTRONOMY AND MATHEMATICS

In the ancient civilizations of Greece, China, and India, astronomers used ingenious mathematical methods to predict solar and lunar eclipses. In Greece, around 400 bc, **Aristotle** presented a convincing argument that the Earth is a sphere, based on the shape of the shadow that falls on the Moon during a lunar eclipse. **Eratosthenes** – another Greek thinker – figured out a fairly accurate value for the diameter of the Earth. In the 2nd century ad, the Greek astronomer **Ptolemy** produced the first comprehensive theory of the universe. He proposed that the planets, the Sun, and the Moon exist on concentric spheres, centered on the Earth, with the fixed stars on the outermost sphere. The Ptolemaic system was laid out in *Almagest*, Ptolemy's

great astronomical encyclopedia, which contained lists of constellations and the magnitude (brightness) of each of 1,022 stars. Translated into Arabic and Latin, it served as a guide to astronomy across much of the world until the 17th century.

THE SOLAR SYSTEM

Ptolemy's theory of the universe could not explain the paths of the planets. **Hipparchus** attempted to fix the theory by suggesting that the planets revolve around points that themselves move around the Earth. This system could not, however, account fully for the motions of celestial objects. In 1543, a solar, or heliocentric, system was proposed by **Nicolaus Copernicus**. His system proposed that the planets, including the Earth, orbit the Sun. It also correctly suggested that the Earth rotates on its axis as it revolves around the Sun. Support for Copernicus came from the careful observations of **Tycho Brahe**. Brahe's data was also used by **Johannes Kepler** to discover three laws of planetary motion. Kepler's laws describe orbits in terms of ellipses, and they

NEWTON'S REFLECTOR

Isaac Newton's reflecting telescope used mirrors rather than lenses to form an image. Incoming light was gathered by a large, curved mirror and then reflected by a smaller mirror into the observer's eye. The image was sharper than that obtained with earlier telescopes.



THE CLOCKWORK UNIVERSE

In the words of the poet Alexander Pope, "Nature and nature's laws lay hid in night: God said, 'Let Newton be!' and all was light." This clockwork model of the solar system, which places the Sun at the center, orbited by the Earth and the Moon, reflects Isaac Newton's view of the universe as a giant machine.

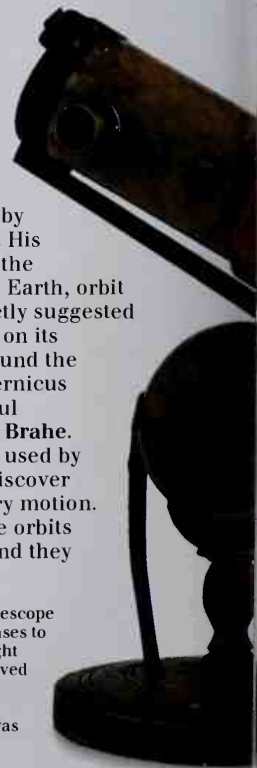

explain the variation in speed of a planet through its orbit (a planet moves more quickly the closer it is to the Sun). Toward the end of the 17th century, **Isaac Newton** published his *Universal Theory of Gravitation*. Newton realized that the force of gravity acts between all objects in the universe and keeps the planets in orbit. The theory fitted Kepler's laws of planetary motion and made possible accurate predictions of the motions of planets and comets around the Sun.

THE TELESCOPE

Isaac Newton invented the first practical reflecting telescope around 1670. (Earlier refracting telescopes of the type used by **Galileo Galilei** tended to distort the image.) By the end of the 17th century, several impressive telescopic observatories had been built. During the 18th century, **William Herschel** conducted several detailed telescopic studies of the sky. He produced a catalog of 848 double stars and, in 1781, discovered the planet Uranus, the first planet to be discovered since ancient times. In 1838, careful telescopic observations and brilliant mathematics enabled **Friedrich Bessel** to calculate the distance of a star for the first time. Telescopes equipped with prisms were used to observe in detail the spectra of stars. These spectroscopic observations meant that astronomers could begin to discover the chemical composition of stars. Combined with photography, telescopes could produce ever more revealing images of celestial objects. In 1846, the telescope was used to discover the planet Neptune. It was not until 1930 that the most distant planet, tiny Pluto, was discovered.

SPACE AND TIME

In the 1920s, **Edwin Hubble** realized that the universe is far larger than had been thought when he discovered that the Andromeda Nebula is in fact a galaxy just like our own. Hubble had discovered that our galaxy is just one of thousands of millions of galaxies in the universe. **Albert Einstein's** two theories of relativity had a profound effect on astrophysics. The special theory of relativity (1905) proposed that energy

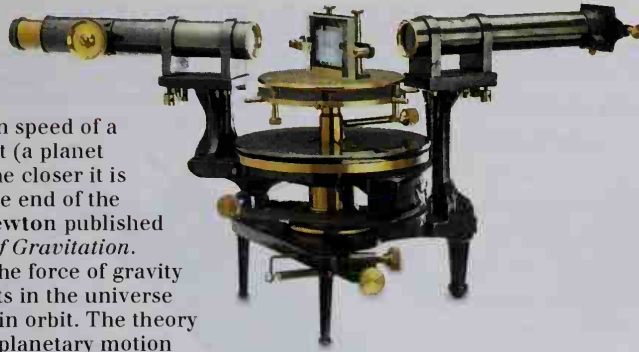

SPECTROMETER

All atoms emit particular wavelengths of light. Spectrometers are used to investigate the light in a spectrum. Analyzing the light emitted by a distant star tells us a great deal about its composition.

has mass, and mass has energy. This idea held the key to understanding the energy source of stars. (It was **Hans Bethe** who first put forward a detailed theory of energy production in stars, in 1939.) Einstein's general theory of relativity (1915) treated gravity as the curvature of space-time and proved more accurate than Newton's theory of gravitation.

MODERN ASTRONOMY

The invention of radio astronomy and the use of space probes to explore the planets drastically changed many of the theories and practices of astronomy. Radio astronomy collects radio waves from stars, galaxies, and interstellar gas, using huge dishes called radio telescopes. It has provided many new insights into cosmic processes. Telescopes have also been built that are sensitive to infrared radiation, ultraviolet radiation, X rays, and gamma rays. In 1964, **Arno Penzias** and **Robert Wilson** discovered cosmic background radiation (CBR). This provided support for the Big Bang theory of cosmology, which suggests that the universe was created in a huge explosion of space and time some 10 to 20 billion years ago. The first successful space probe, the Russian lunar probe, *Luna 1*, was launched in 1959. Since then, a much more detailed understanding of the solar system has been built up by sending space probes to most planets, as well as some comets and asteroids. Similarly, the use of telescopes in orbit above the Earth's atmosphere has enabled astronomers to see into space with yet more clarity. The most celebrated of these is the *Hubble Space Telescope*, launched in 1990, which has provided stunning new views of the planets, as well as of distant stars, galaxies, and nebulas.

TIMELINE OF DISCOVERIES

The Egyptian calendar of 360 days (12 months of 30 days each) is drawn up based on observations of the Sun and the Moon	4000 BC	
Aristotle puts the Earth at the center of the universe, a belief that dominates until the 15th century	355 BC	Evidence of systematic astronomical observations in Egypt, Babylonia, India, and China
Ptolemy records the positions of 1,022 stars, dividing them into 48 constellations, in his book, <i>Almagest</i>	150 BC	
Tycho Brahe publishes his great star catalog, which gives accurate positions for about 770 stars	1596	Nicolaus Copernicus places the Sun at the center of the universe in his book, <i>On the Revolutions of Celestial Objects</i>
Johannes Kepler establishes the elliptical motion of the planets	1609	Hans Lippershey invents the first telescope
Isaac Newton establishes the laws of gravitation governing celestial bodies. In 1668 he invents the reflecting telescope	1667	Galileo Galilei uses a telescope to discover four of Jupiter's moons. He also shows that Venus, like the Moon, has phases, adding support to the idea that the Sun is at the center of the universe
William Herschel discovers Uranus	1781	Edmond Halley predicts the return of what comes to be known as Halley's comet
The first photographs of stars are taken at Harvard Observatory, Boston, Massachusetts	1849	Johann Galle and Heinrich D'Arrest discover Neptune
The notion of an expanding universe is suggested by American astronomer Vesto Slipher	1919	Albert Einstein discovers mass/energy equivalence, the key to understanding the energy source of stars
Edwin Hubble finds strong evidence in support of an expanding universe	1929	Georges Lemaitre formulates what comes to be known as the Big Bang theory of the origin of the universe
Radio signals from the Milky Way are discovered by Karl Jansky	1932	Pluto is discovered by Clyde Tombaugh
The first pulsar (pulsating star) is discovered by Jocelyn Bell Burnell	1967	Arno Penzias and Robert Wilson discover cosmic background radiation, believed to be a remnant of the Big Bang
The <i>Hubble Space Telescope</i> is launched, the first large, optical telescope to be placed above the Earth's atmosphere	1990	The <i>Giotto</i> space probe sends back the first images of a comet's nucleus, in this case Halley's comet
NASA's <i>Pathfinder</i> lands on Mars. Its unique rover, <i>Sojourner</i> , samples rocks and soils	1997	<i>COBE</i> (Cosmic Microwave Background Explorer) provides further evidence of the Big Bang origins of the universe

Telescopes

THE HUMAN EYE HAS ONLY a small opening (aperture) to collect light, and its magnification is fixed. Optical telescopes, which collect visible light, have a much larger aperture than the eye, and so collect much more light. This means that much fainter objects can be observed, and also that features that are too close together for the eye to distinguish can be seen as separate objects (resolved). The magnification of a telescope is less important than the size of its aperture, especially when observing stars, which are so far away that they appear only as a point of light, whatever the magnification of the telescope used. The Earth's turbulent atmosphere distorts the light that reaches Earth-based telescopes. Far better images can be obtained by placing a telescope in space. The most famous space telescope is the *Hubble Space Telescope*, which has provided astronomers with exciting new insights into star formation, as well as having produced stunning photographs of objects within the solar system. Modern astronomy relies increasingly on telescopes that are sensitive to parts of the electromagnetic spectrum other than visible light.

REFRACTION AND REFLECTION

A refracting telescope, or refractor, produces images using only lenses (normally two of them). A reflecting telescope produces an image using a large mirror. This image is magnified by a smaller eyepiece lens, which has a short focal length. The degree to which the image is magnified depends upon the focal lengths of the mirror and the eyepiece lens.

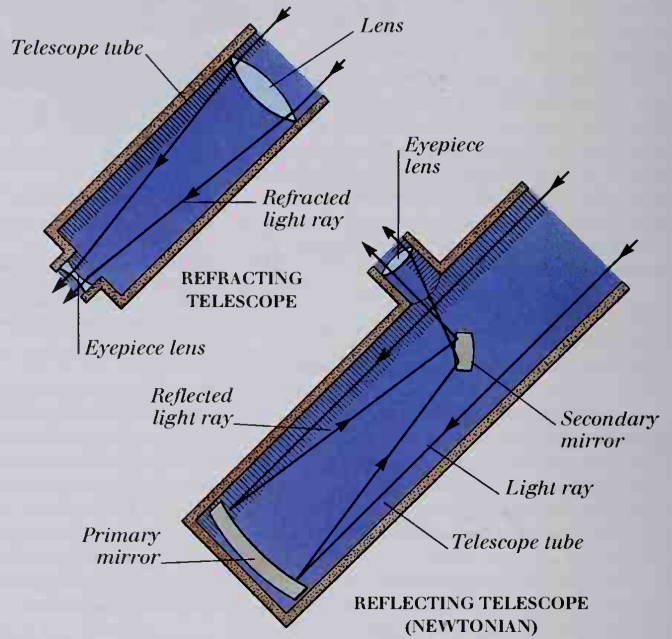

HUBBLE SPACE TELESCOPE

The *Hubble Space Telescope (HST)* is in orbit 600 kilometers above the Earth's surface, well away from the distorting effects of the Earth's atmosphere. Because it is above the atmosphere, the *HST's* resolution is ten times better than that of a ground-based telescope. It is a reflecting

telescope with a primary mirror 2.4 meters in diameter. Its cameras and **spectrographs** are sensitive to infrared, visible light, and ultraviolet. Images from its cameras are gathered electronically, using a charge coupled device (CCD) and beamed back to the Earth.

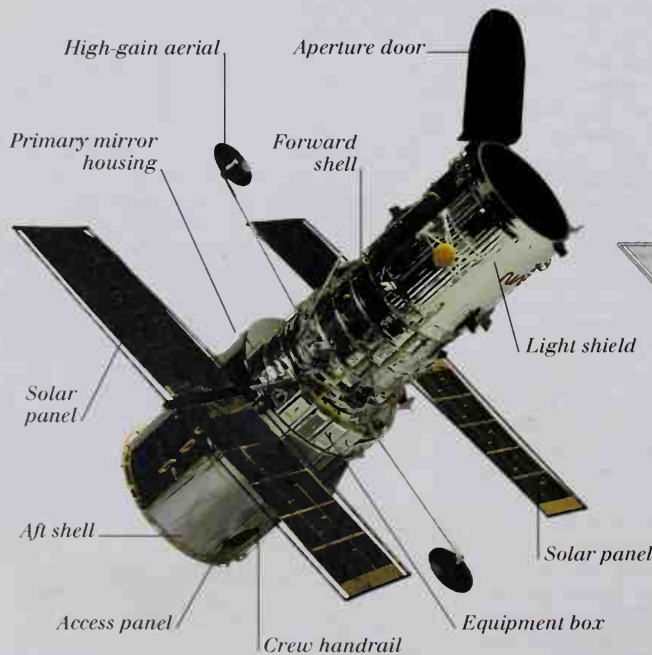

EXTERNAL FEATURES OF HUBBLE

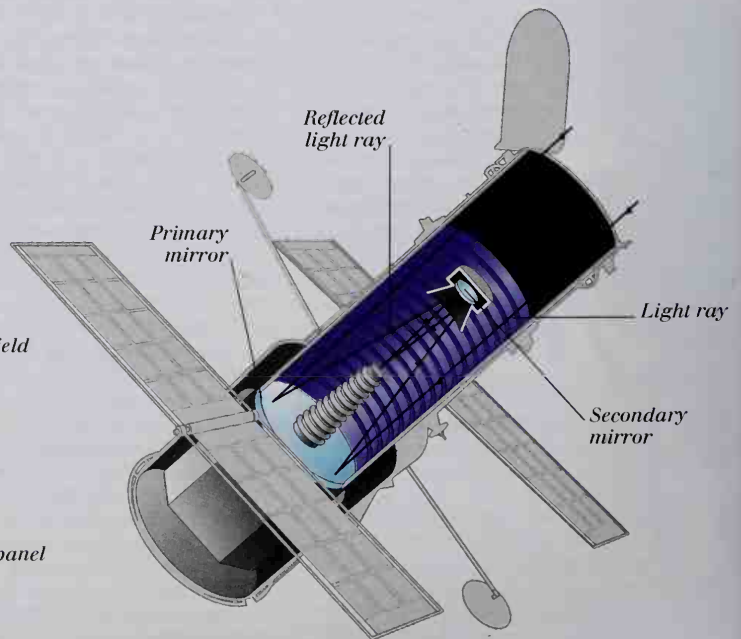

HOW HUBBLE WORKS

ELECTROMAGNETIC SPECTRUM

Radio waves are not readily absorbed by any part of the atmosphere. **Infrared** radiation is absorbed by water in clouds but visible light passes through the atmosphere. **Ultraviolet radiation and gamma**

rays are absorbed by ozone concentrated at a level higher than the clouds. For this reason, ultraviolet and gamma-ray astronomy is effectively carried out only using orbiting telescopes.

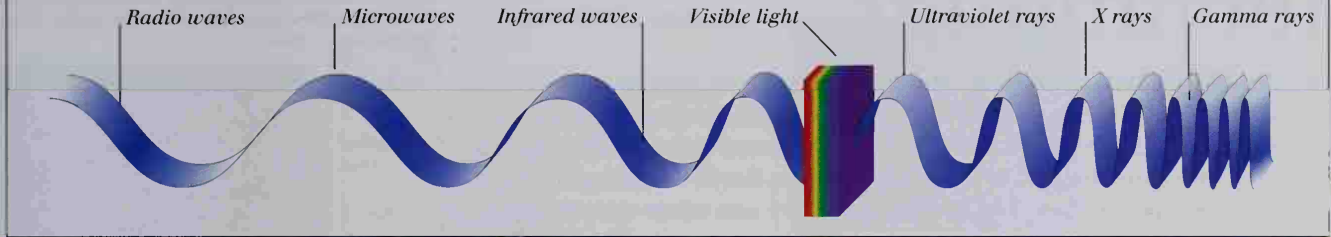

ORBITING AND GROUND-BASED TELESCOPES

The first telescopes sensitive to parts of the electromagnetic spectrum other than light were radio telescopes. The long wavelengths of radio waves mean that huge dishes are needed if the images they produce are to resolve any detail. It is often possible to learn more about the nature

of a galaxy by examining the data collected by radio telescopes than from images produced in visible light. Infrared astronomy is particularly useful for studying the Sun and the planets, while X rays and gamma rays are emitted only by very powerful galactic centers and black holes.

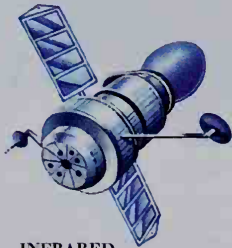

INFRARED
TELESCOPE

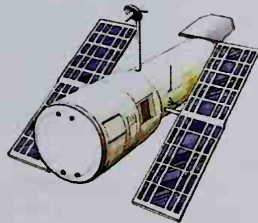

ULTRAVIOLET
TELESCOPE



X-RAY
TELESCOPE

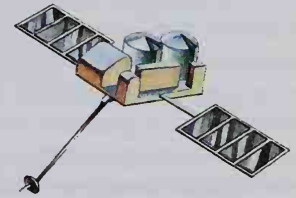

GAMMA-RAY
TELESCOPE



RADIO
TELESCOPE

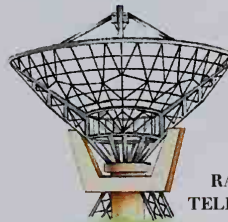

RADAR
TELESCOPE

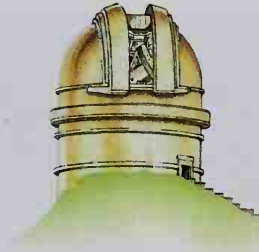

VISIBLE-LIGHT
TELESCOPE

TWO IMAGES OF OUR GALAXY

These images show our galaxy, the Milky Way Galaxy. The upper image was taken by the Infrared Astronomical Telescope (IRAS), while the lower image was produced by a gamma-ray observatory. Both are false-color images (neither infrared nor gamma radiation has any true color). The infrared image is very bright along the galactic plane (disk), where

hot young stars are common. The gamma-ray image shows a contrast between the center, or nucleus, of the galaxy and the rest of the disk. Gamma rays are given out only by extremely energetic sources – there may be a massive black hole at the center of our galaxy (see pp. 350-351). This image also highlights activity above and below the galactic plane.



INFRARED IMAGE



GAMMA-RAY IMAGE

Observational techniques

ASTRONOMERS HAVE DEvised many techniques and devices to help them make the most of their observations. For example, accurate measurement of the position in the sky of a star taken at different times of the year can lead to a determination of its distance from the Earth – making use of an effect known as parallax. The positions of stars and other astronomical objects are given as points in a coordinate system (see pp. 366-367). Astronomers imagine the sky as a hollow sphere, with the Earth at its center. Coordinates called right ascension (RA) and declination (Dec) have the same meaning for the sphere as longitude and latitude do for the Earth's surface. Astronomers measure the brightness of a star in terms of its apparent magnitude. This is not necessarily a clue to its actual luminosity, which is measured instead by absolute magnitude. A device called a blink comparator enables astronomers to highlight objects that change their appearance or position, including supernovas or asteroids. Analysis of the spectrum of a star's light can tell astronomers which chemical elements are present in the star, enabling stars to be categorized by their spectral type.

PARALLAX SHIFT

The apparent position of nearby stars is different when viewed from different points in the Earth's orbit. This difference is called parallax shift. The parallax shift of even the nearest stars is tiny, but using simple geometry it can be used to calculate the distance of a star with some accuracy.

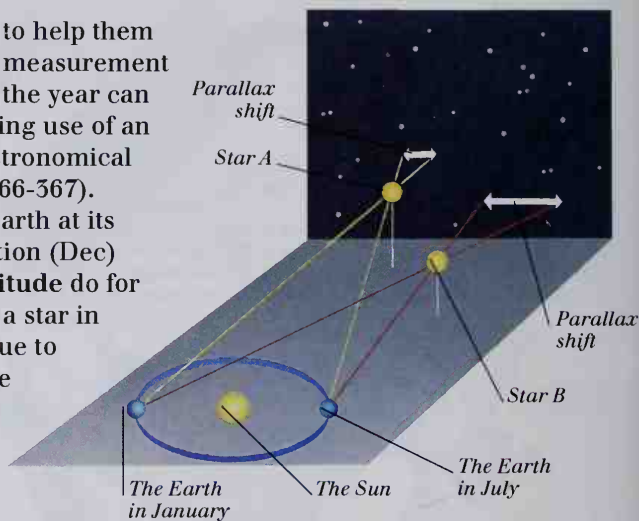

CELESTIAL SPHERE

Directly above the Earth's equator is the imaginary celestial equator, and directly above the Earth's poles are the imaginary celestial poles. The path of the Sun on the celestial sphere over one year follows a curve called the ecliptic, which is tilted at 23.5° to the celestial equator. Right ascension (RA) is the horizontal angular coordinate, and declination (Dec) is the vertical angular coordinate. RA is expressed in hours and minutes, where one complete revolution is 24 hours. Dec is expressed in degrees above (+) or below (-) the celestial equator. From the Earth, the celestial sphere appears to turn once every day, because of the planet's rotation.

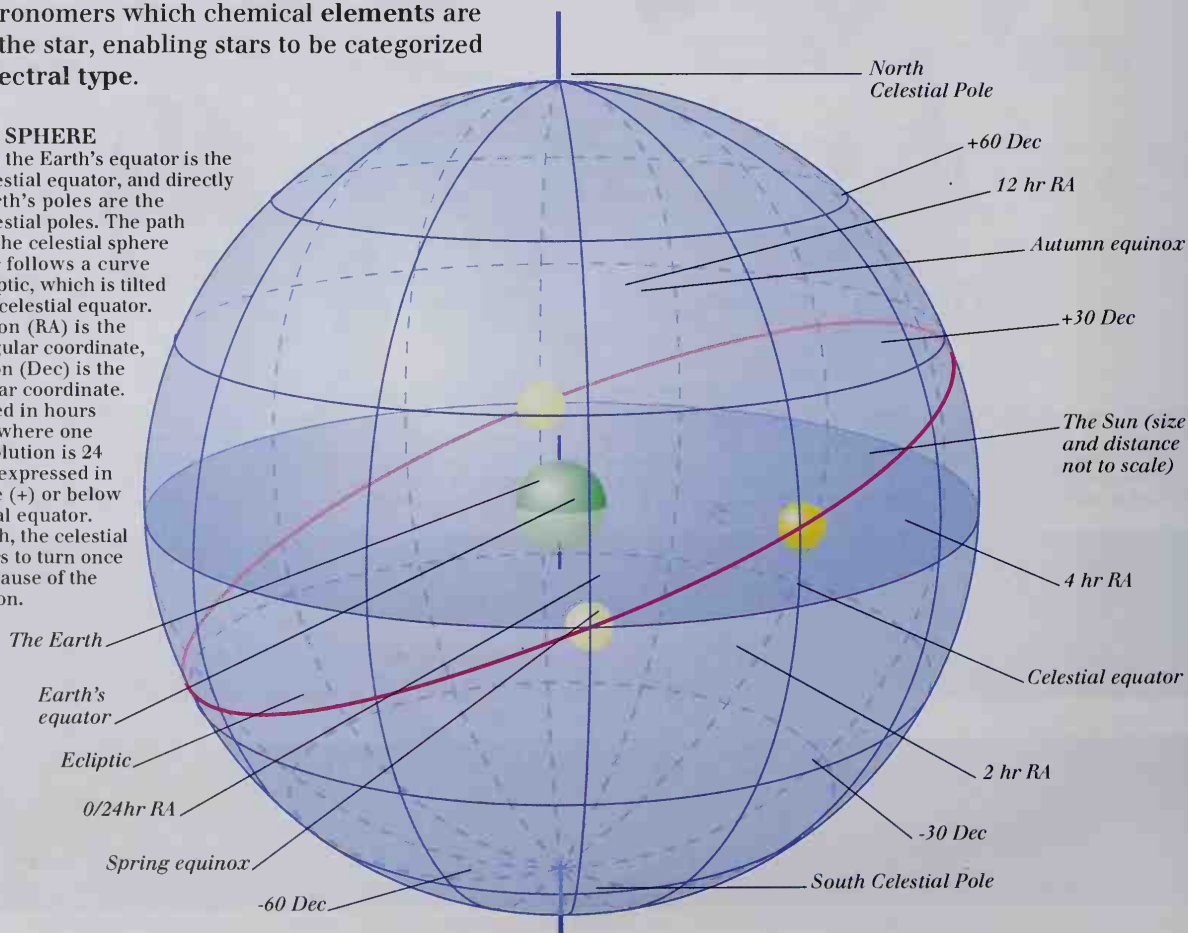

STAR MAGNITUDES

The brighter a star or planet appears in the sky, the lower its apparent magnitude is said to be. The absolute magnitude of a star is the magnitude it would appear at a distance of ten parsecs (32.6 light years). The apparent magnitude of the Sun is -26.7, while its absolute magnitude is +4.8.

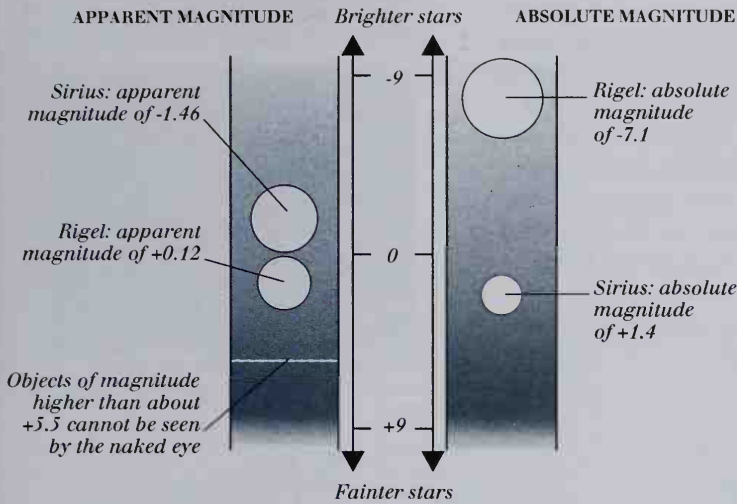

BLINK COMPARATOR

Blink comparators flash up time-lapsed photographs of the same part of the sky. Any differences between the photographs – caused by objects moving against the background of “fixed” stars – are immediately apparent.

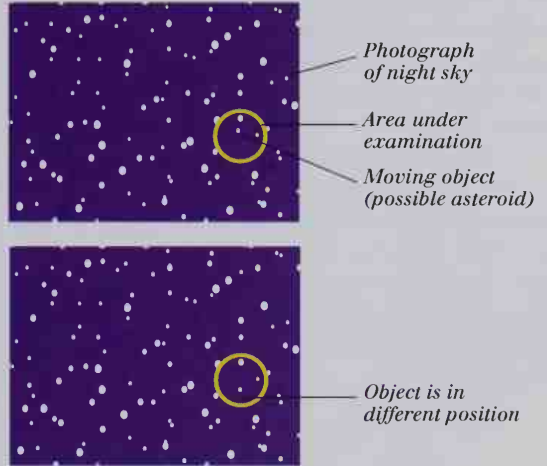

RED SHIFT

Wavelengths of light (or other electromagnetic radiation) emitted by a star or galaxy moving rapidly away from the Earth are lengthened, an effect known as Doppler redshift. The opposite effect is called Doppler blueshift. Astronomers can figure out redshifts or blueshifts by

measuring the wavelengths of known spectral lines (see below) and comparing them with the wavelengths of those lines from a stationary source. The objects moving away fastest are distant quasars, which have a correspondingly high degree of redshift.



STELLAR SPECTRAL ABSORPTION LINES

When starlight is analyzed by being passed through a prism or a diffraction grating (a piece of glass with closely spaced parallel lines ruled on it), many dark lines are seen against the resulting spectrum. These lines are caused by absorption of light by atoms

in stars and are characteristic of particular chemical elements. Stellar spectra can therefore tell astronomers much about the chemical composition of a star.

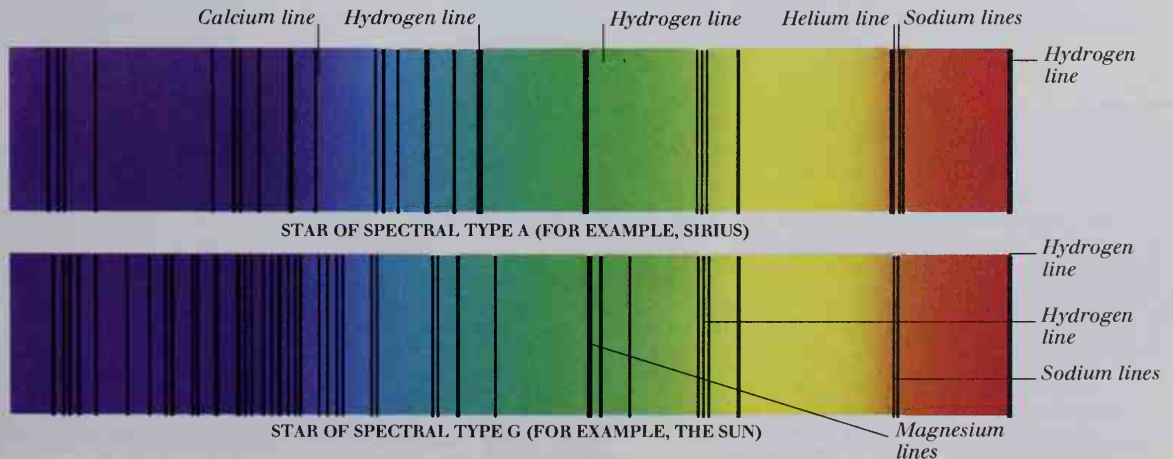

Space probes

MOST SPACE PROBES ARE SENT OUT to gather information about planets. One of the most successful space probes was *Voyager 2*. It visited four planets in total and made many important discoveries. Like most space probes, it carried other instruments as well as cameras. Information from these instruments was sent back to the Earth as radio signals, which were detected using radio telescopes (see pp. 298-299). The *Galileo* probe traveled to Jupiter (see pp. 316-317) and made extensive observations of the planet and its moons. It also sent a small descent probe into the atmosphere to gather data. Some probes are designed to land on planets. Landers, as these are called, have been sent to the surfaces of the Moon (see pp. 310-311) and Mars (see pp. 314-315). Space probes do not visit only planets; a few probes have visited comets and asteroids (see pp. 322-323), while others have been sent into orbit around the Sun.

INFORMATION FOR ALIENS

The American space probe *Pioneer 10* passed Jupiter in 1973, and *Pioneer 11* passed Saturn in 1974. Both probes eventually left the Solar system but it is highly unlikely that they will ever be found by some extraterrestrial life form. In case they do, however, both probes carry plaques with information about the Earth.

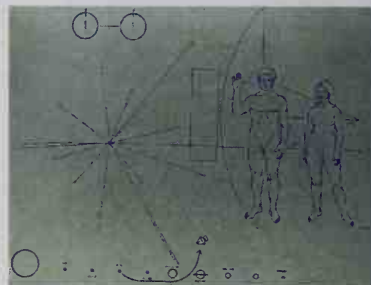

INFORMATION PLAQUE FROM PIONEER PROBES

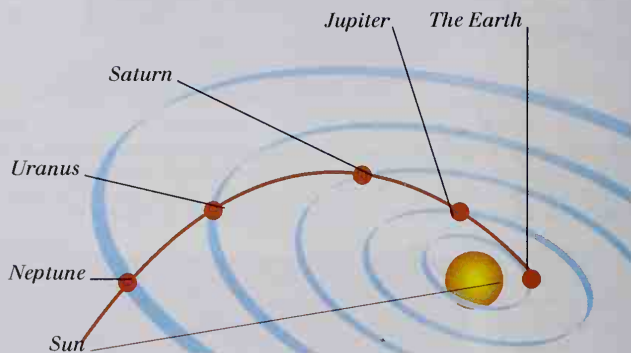

VOYAGER 2'S JOURNEY

Voyager 2 was probably the most successful space probe ever launched. It left the Earth in August 1977 and passed Jupiter in July 1979. It passed Saturn in August 1981, Uranus in January 1986, and Neptune in August 1989. The probe will remain operational until 2020 and will send back information about the Sun's magnetic field.

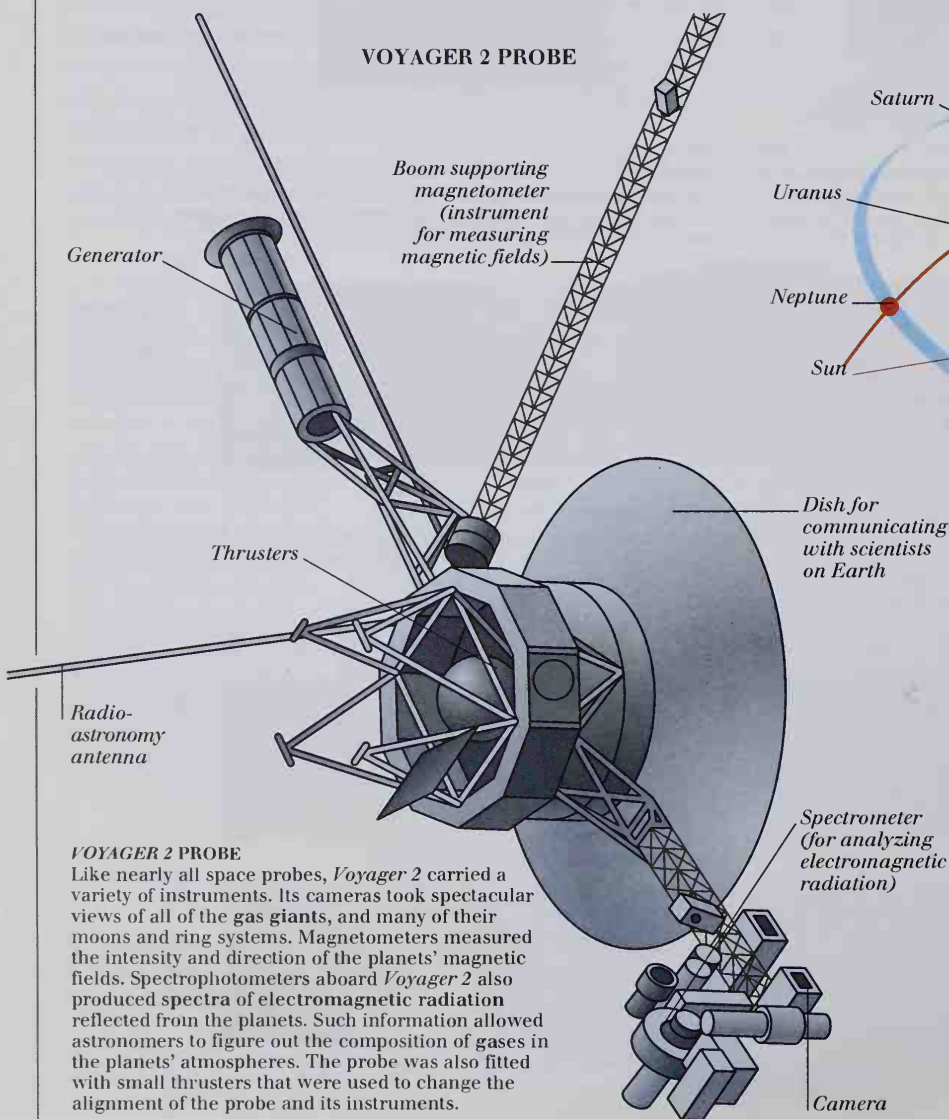

VOYAGER 2 PROBE

Like nearly all space probes, *Voyager 2* carried a variety of instruments. Its cameras took spectacular views of all of the gas giants, and many of their moons and ring systems. Magnetometers measured the intensity and direction of the planets' magnetic fields. Spectrophotometers aboard *Voyager 2* also produced spectra of electromagnetic radiation reflected from the planets. Such information allowed astronomers to figure out the composition of gases in the planets' atmospheres. The probe was also fitted with small thrusters that were used to change the alignment of the probe and its instruments.



IMAGES FROM VOYAGER 2

Voyager 2's flyby of Neptune led to the discovery of six previously unknown moons of the planet, plus three rings. It also carried out accurate measurements of the planet's magnetic field. Shown here is a *Voyager 2* image of Neptune with Triton, the largest of Neptune's moons.

THE GALILEO PROBE'S MISSION TO JUPITER

FLIGHT PATH

The *Galileo* probe was launched in October 1989 and reached Jupiter in the summer of 1995. The probe was assisted on its journey by the gravitational effect of Venus, which it passed in January 1990. In July 1994, *Galileo* observed the collision of comet Shoemaker-Levy 9 with Jupiter's atmosphere (see pp. 316-317) and on July 15 1995, an atmospheric probe was dropped into the clouds of Jupiter's upper atmosphere.

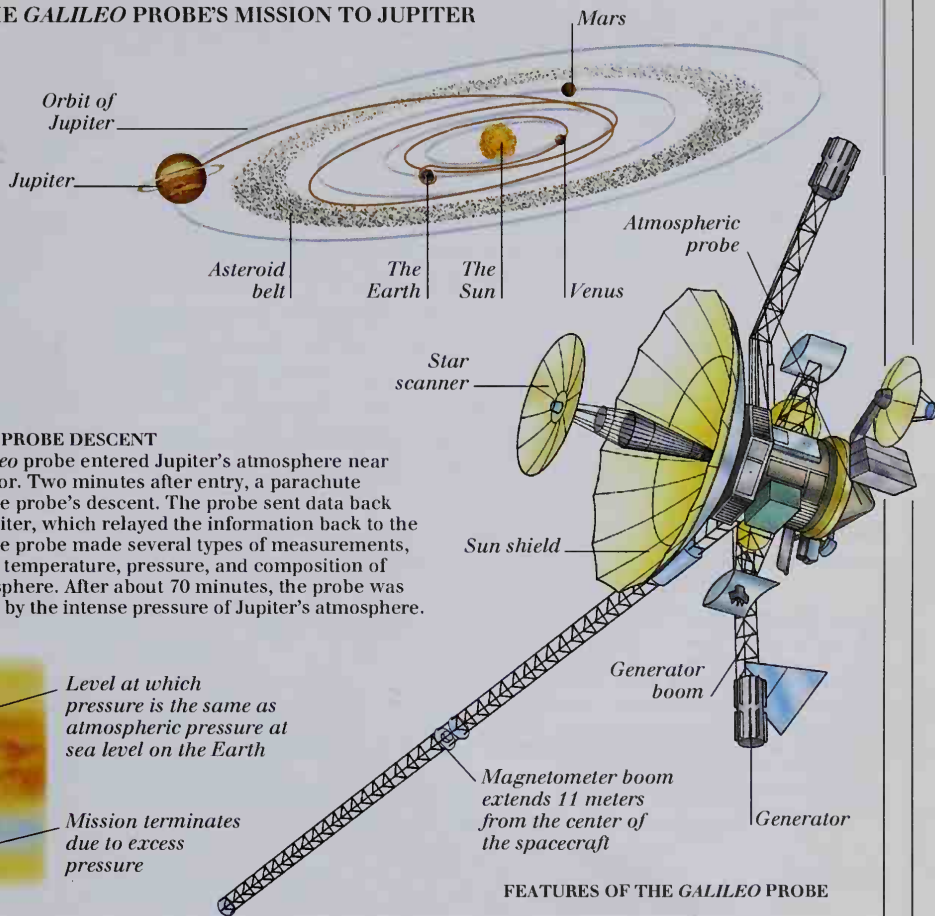

GALILEO PROBE DESCENT

The *Galileo* probe entered Jupiter's atmosphere near the equator. Two minutes after entry, a parachute slowed the probe's descent. The probe sent data back to the orbiter, which relayed the information back to the Earth. The probe made several types of measurements, including temperature, pressure, and composition of the atmosphere. After about 70 minutes, the probe was destroyed by the intense pressure of Jupiter's atmosphere.

INVESTIGATING THE SURFACE OF MARS

In the summer of 1976, two *Viking* landers were sent to Mars. Each had an orbiter that relayed signals from the lander to the Earth. The landers deployed robotic arms to collect the Martian rock and soil, and a series

of chemical and biochemical tests were carried out on the samples. One set of experiments tested for signs of life on Mars, but none were found. The landers also carried instruments to study the Martian weather.

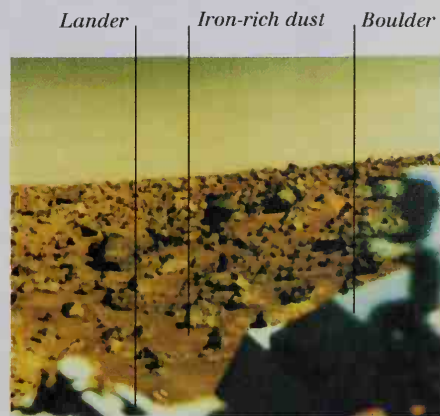
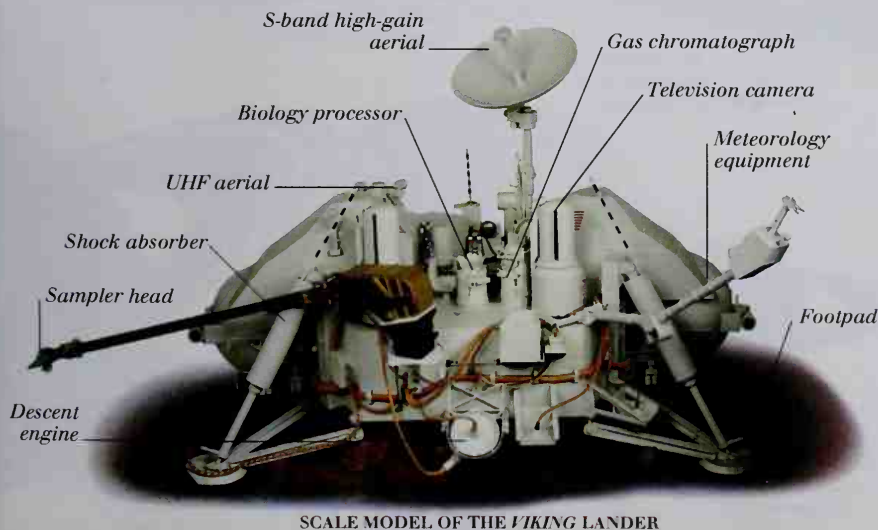

IMAGES FROM THE VIKING LANDERS
The *Viking* landers took the first ever close-up photographs of the surface of Mars. Many of the surface features, such as dunes and boulders, are similar to those observed on the Earth.

SCALE MODEL OF THE VIKING LANDER

The Solar System

THE SOLAR SYSTEM CONSISTS OF THE SUN, the nine planets and their satellites, and millions of comets, asteroids, and meteoroids (see pp. 322-323). Most of the objects that currently orbit the Sun probably formed millions of years ago from a rotating disk of gas and dust left over from the Sun's formation. The mass of the Sun is far greater than the combined masses of all the planets, and so it commands a position at the center of the solar system. All of the planets are held in orbit by **gravitational forces** (see pp. 308-309). The four inner planets are relatively small, rocky bodies. They include the Earth (see pp. 270-271) and are often referred to as the terrestrial planets. The outer planets, with the exception of Pluto, are all **gas giants** – huge planets that consist largely of gases in various forms. Pluto is unlike the other planets in many ways and may have come from the Kuiper Belt (see pp. 320-321) – a band of rocky bodies outside the main part of the Solar System.

ORBITS OF THE INNER PLANETS

The orbits of the inner planets are nearly circular and are all very well aligned with the **ecliptic plane**. Between Mars – the outermost terrestrial planet – and Jupiter – the first of the gas giants – lies the asteroid belt. This is essentially debris left over from the formation of the solar system. Jupiter's gravity prevents this debris coming together to form a planet.

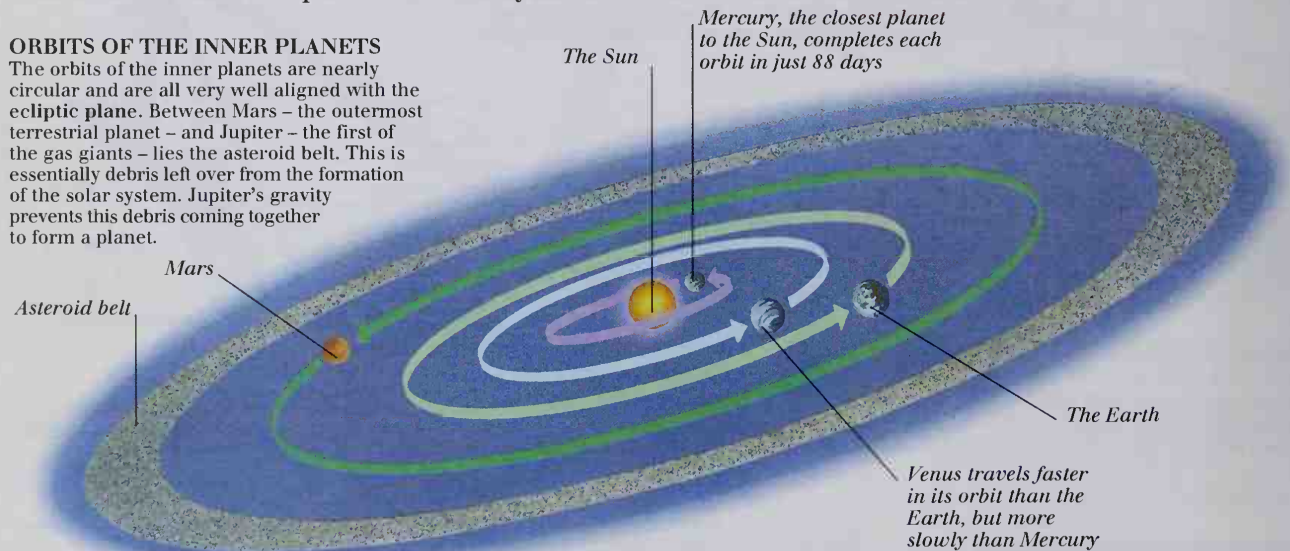

BIRTH OF THE SOLAR SYSTEM

The Sun was created from a nebulous cloud of gas and dust around 4.6 billion years ago. The material that was left over from the solar nebula formed a flat, rotating disk. (This remaining material amounted to less than one percent of the total mass of the solar System.) Bodies called **protoplanets** condensed out of this disk and clumped together, under the influence of **gravity**, to become planets and asteroids.

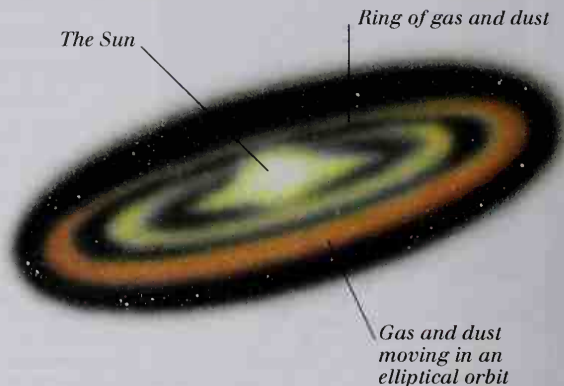

ALMOST A STAR

The gas giant Jupiter is by far the largest planet in the solar system. It has a diameter more than eleven times as great as the Earth's. The Sun is even larger, having a diameter more than one hundred times that of the Earth's. The Sun is so massive that gravitational forces created enough heat and pressure at its core for nuclear reactions to begin. This is why the Sun is a star. If Jupiter's mass were to increase by a factor of 75, nuclear reactions would start at its core, and it too would become a star.



Pluto, the smallest of the planets, has a diameter of just 2,290 km

All the planets revolve around the Sun in the same direction

Average distance from Pluto to the Sun is about 5,900 million km

Inner planetary orbits

The Sun

Saturn

Asteroid belt

Jupiter

The axis of rotation of Uranus is tilted to the ecliptic by more than 90°

Neptune

Pluto's orbit is not aligned with the ecliptic plane

Pluto, the farthest planet from the Sun for most of its orbit, completes each circuit in 248.5 Earth years

ORBITS OF THE OUTER PLANETS

It is possible to get a sense of the size of the solar system from measurements of the amount of time it takes for light from the Sun (which travels at around 300,000 km per second) to reach the planets. Sunlight takes just over eight minutes to reach the Earth, and 45 minutes to reach Jupiter. However, it takes nearly seven hours to reach the planet Pluto when the planet is at **aphelion** (its farthest point from the Sun).

Jupiter, the largest of the planets, has a diameter of 142,984 km

The Sun has a diameter of 1,392,000 km

The Earth has a diameter of 12,756 km

Venus has a diameter of 12,104 km

Mars, the red planet, has a diameter of 6,786 km

Mercury has a diameter of 4,879 km

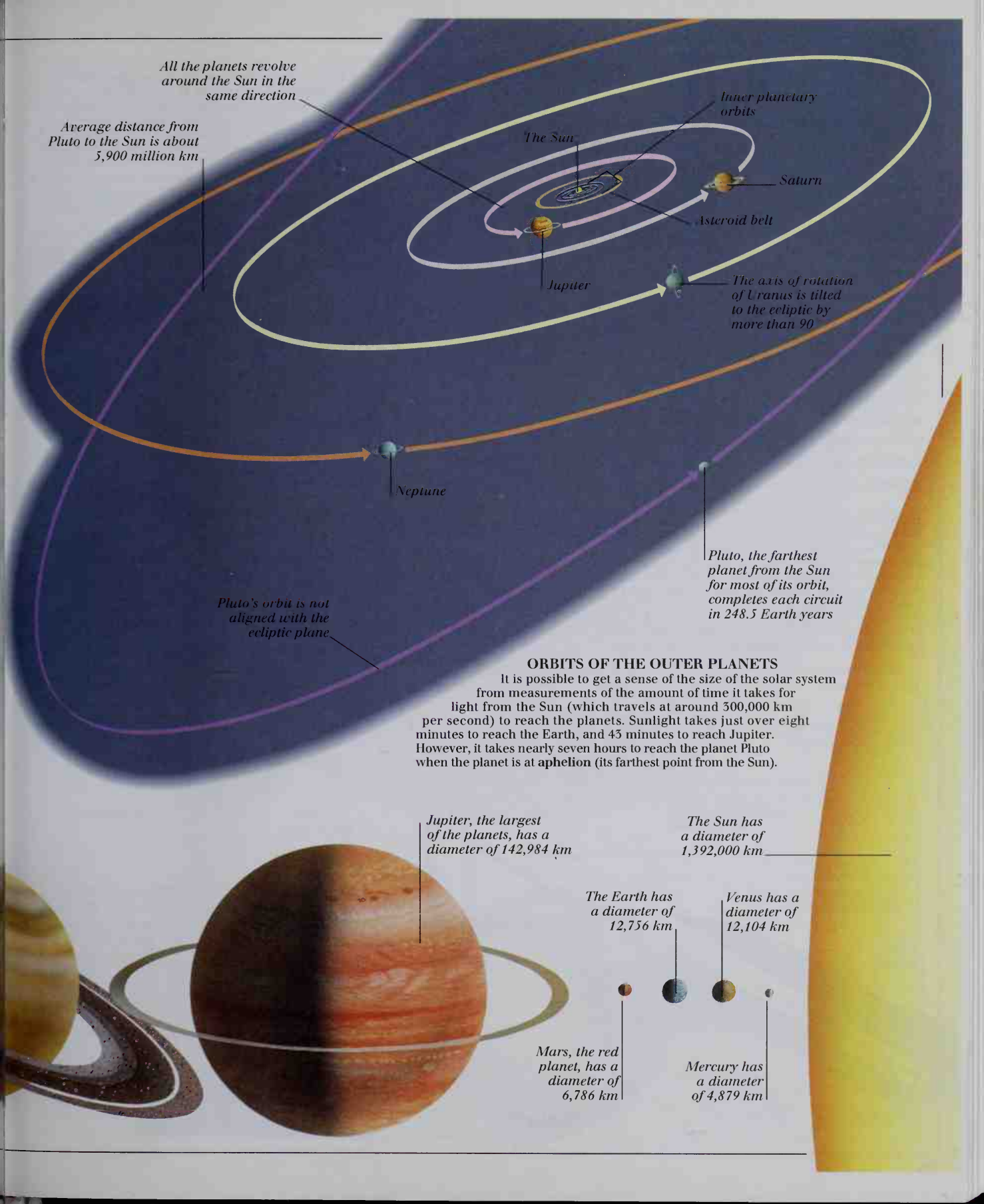

The Sun

THE SUN IS A STAR at the center of our solar system (see pp. 304-305). It is about 1.4 million kilometers in diameter and dominates the sky during the daytime. The Sun is made almost entirely of hydrogen and helium. Nuclear fusion reactions at the Sun's core convert hydrogen into helium, releasing huge amounts of energy. Some of this energy reaches the Earth as sunlight. This is scattered by air molecules in the Earth's atmosphere, creating a blue sky. Sunlight is the source of nearly all of the energy on the Earth. This life-sustaining energy is absorbed indirectly by most living organisms, but is absorbed directly by plants in a process called **photosynthesis** (see pp. 148-149). Much can be discovered about the Sun from Earth-based observations. Projections of the Sun's image reveal surface features such as sunspots, and analysis of the solar spectrum (see pp. 300-301) tells us much about the composition of the Sun. The normally invisible outer layers of the Sun can be studied during a solar eclipse, when the Moon blocks out the Sun's light.

OBSERVING THE SUN

It is very dangerous to look directly at the Sun through a telescope or even with the naked eye. Astronomers do, however, use telescopes to observe the Sun. They do this by projecting the Sun's image on to a white surface or photographic film. Astronomers can also pass sunlight through a **spectrometer** in order to study its component colors. There are several large telescopes that are dedicated mainly to solar observations. One of the best known of these is the McNath-Pierce facility (see below) at Kitt Peak National Observatory in Arizona.

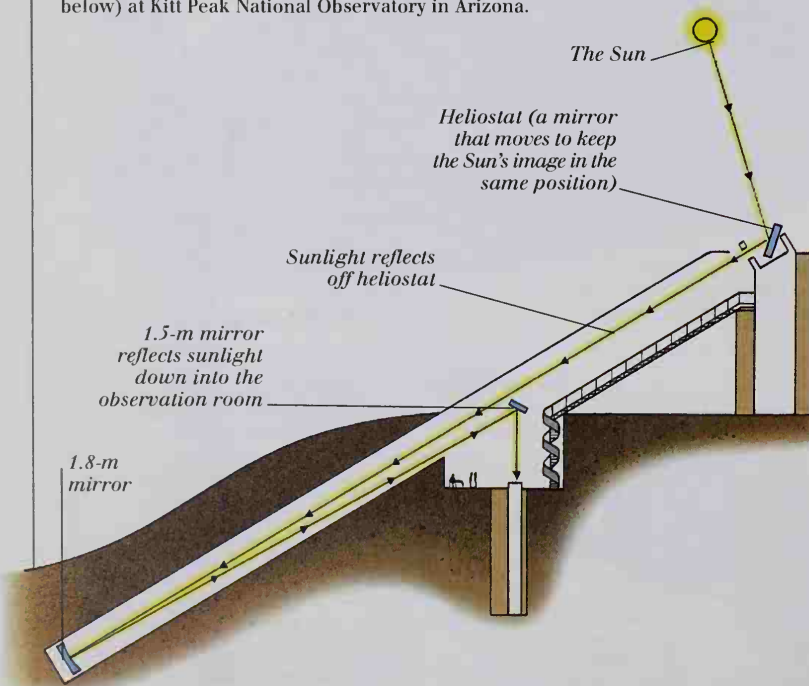

SUNSPOTS

Sunspots appear dark in photographs because they are cooler than the rest of the surface of the Sun. They are caused by variations in the Sun's magnetism, which prevents convection from bringing hotter gas to some parts of the surface. Observation of sunspots has revealed an eleven-year cycle of solar activity. This is referred to as the sunspot cycle, although many other signs of solar activity also vary according to the same cycle.

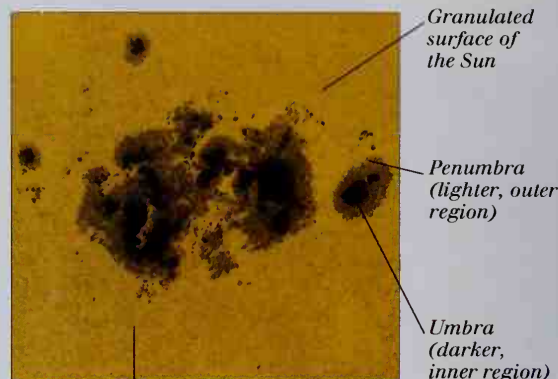

Photosphere temperature about 5,500 °C

HOW A SOLAR ECLIPSE OCCURS

Occasionally, the Moon passes directly in front of the Sun – as viewed from the Earth – and causes a solar eclipse. During an eclipse, the Moon blocks out the disk of the Sun, allowing astronomers to study the solar atmosphere. A solar eclipse can happen only at new moon, but does not occur with every new moon because the Moon's orbit is tilted slightly compared to the ecliptic plane.

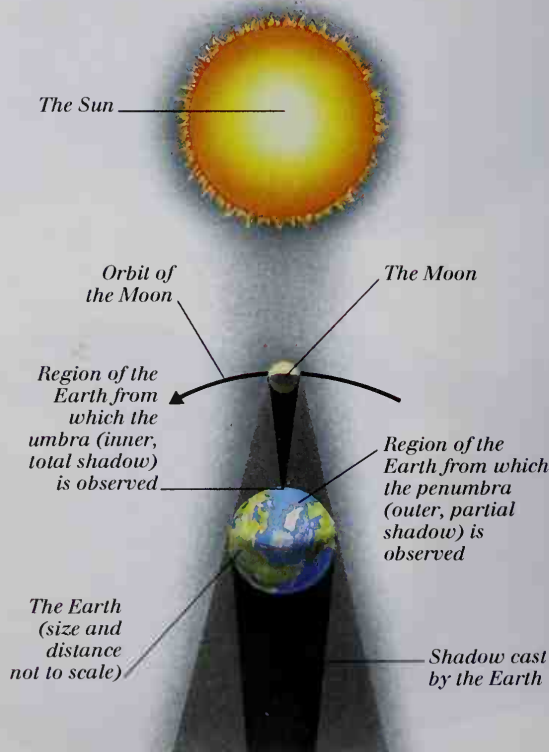

THE STRUCTURE OF THE SUN

The hot gas of the photosphere (the Sun's visible surface) produces light by **incandescence**, and it is this light that we see from the Earth. Other features of the photosphere – such as prominences, flares, and sunspots – are all related to the Sun's magnetism. Beneath the photosphere are the convective zone (in which hot gas rises constantly to the surface), the radiative zone, and the core, which is the source of the Sun's energy.

Corona (outer atmosphere) extends millions of miles into space

Chromosphere (inner atmosphere) up to 10,000 km thick

Spicule (vertical jet of gas about 10,000 km) high

Photosphere (visible surface)

Prominence

Filament (prominence seen against the photosphere)

Sunspot (cool region)

Solar flare (sudden release of energy associated with sunspots)

Convective zone (about 140,000 km thick)

Radiative zone about 380,000 km thick

Corona temperature about 2 million °C

Chromosphere temperature about 10,000 °C

Core temperature about 15 million °C

Photosphere temperature about 5,500 °C

Supergranule (convection cell)

Granulated surface caused by convection

Macrospicule (vertical jet of hot gas about 40,000 km high)

Gas loop (looped prominence)

ENERGY EMISSIONS FROM THE SUN

The main fusion reaction that occurs at the Sun's core is called the proton-proton chain, in which protons (the nuclei of hydrogen atoms) fuse to form helium nuclei. Energy, mostly in the form of gamma radiation, interacts with matter in the radiative zone, causing heating. Heated gas then rises to the photosphere by convection. Some of the energy, however, is carried away by particles called neutrinos, which are a by-product of the proton-proton chain.

Proton-proton reaction at core produces vast amounts of energy

Energy produced as gamma radiation takes hundreds of thousands of years to reach the photosphere (surface of the Sun)

The Sun

Neutrinos pass through the Sun's layers without being absorbed

Radiation from the photosphere (sunlight) consists mostly of infrared, ultraviolet, and visible light

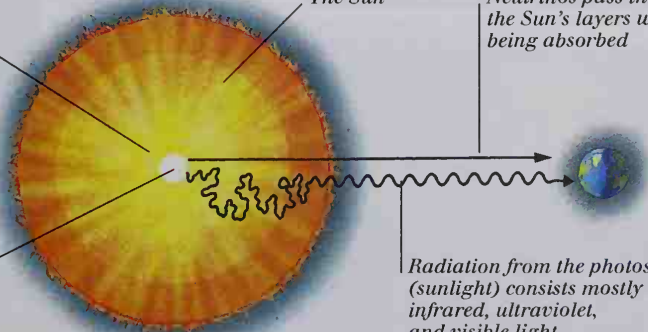

Planetary science

THE WORD "PLANET" comes from a Greek word meaning "wanderer," as planets appear to move across the sky relative to the fixed stars. All the planets of the solar system (see pp. 304-305) move around the Sun in paths called orbits. In recent years, several planets have been discovered orbiting distant stars, confirming a long-held belief that planetary systems other than our own do exist. Most of the planets have one or more natural satellites (moons) in orbit around them. In addition to moons, all of the **gas giants** – Jupiter, Saturn, Uranus, and Neptune – have ring systems. The most spectacular ring system in the solar system, that around the planet Saturn (see pp. 318-319), can be observed through a small telescope. Planetary rings are composed of millions of chunks of rock and ice, ranging in size from tiny particles to boulder-sized pieces. Craters are a feature common to the **terrestrial planets** – and to most natural satellites. They are caused by the impact of comets and meteorites (see pp. 322-333). Much of the history of a planet or satellite can be ascertained by studying its craters. Knowledge of the planets has been greatly enhanced by the use of space probes (see pp. 302-303), which have discovered new satellites and rings, and have mapped craters and sent other valuable data back to the Earth.

NATURAL SATELLITES

A satellite is any object in orbit around a planet. Artificial satellites form part of the telecommunications network. Natural satellites are called moons, and all the planets in the Solar System – with the exceptions of Mercury and Venus (see pp. 312-313) – have them. Moons are generally named after characters from literature or mythology. All of the 15 known moons of Uranus, for example, have Shakespearean characters' names, including Titiana and Oberon..



Titania is 1,600 km in diameter

Surface is covered with small craters

TITANIA



Oberon is 1,550 km in diameter

Bright patches may have been caused by the formation of craters on an icy surface

OBERON

PLANETARY ORBIT

The shape of each of the orbits of the planets is an ellipse: a "flattened" circle. The orbits of some planets are more flattened, or **eccentric**, than others. The orbits of most of the planets lie more or less in one plane, called the **ecliptic plane**. Comets also orbit the Sun, but are not restricted to this plane.

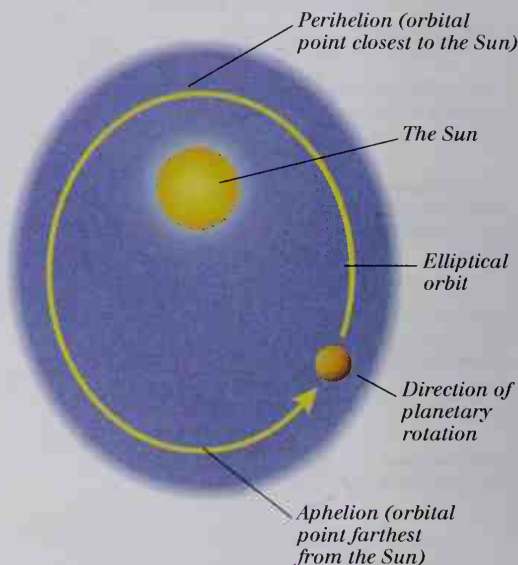

STAR WOBBLE

Although distant planets are too far away to be seen from the Earth, astronomers have been able to discover several of them by examining their **gravitational** effects on the stars that they orbit. Each of these planets causes its star to wobble on its axis, and this can be observed from the Earth using powerful telescopes. As the star wobbles, there is a shift in the **wavelengths of radiation** it emits – an effect known as **Döppler shift**. Astronomers can calculate the mass of the planet from the degree of shift.

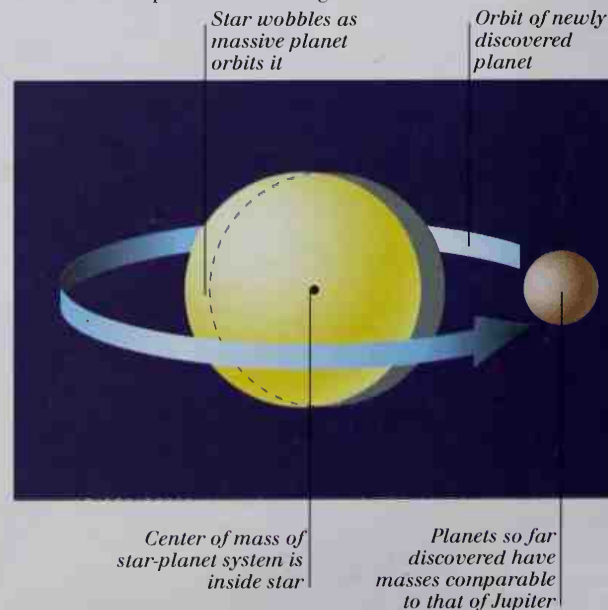

RING SYSTEMS

The ring systems of the gas giants differ slightly from one another, but most seem to consist of millions of rocky or icy particles. The smallest of these particles is perhaps the size of a grape, while the largest is the size of a boulder. The origin of the material making up the rings is uncertain. Some may be the result of debris left over from planetary formation, while others may be created from moons that have broken up.

DUST LANES

Many rings have an intricate structure. In some rings, like those around Uranus (shown below), there are dust lanes where there is little or no material. Dust lanes and gaps between rings are probably due to the complex gravitational interaction of the planets with their satellites.

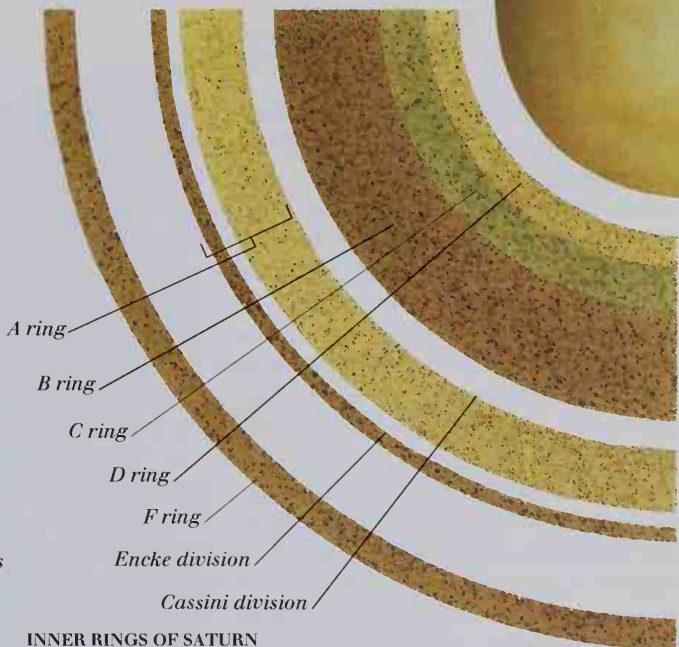

INNER RINGS OF SATURN

Saturn has the most impressive of all the ring systems. Until 1977, it was the only ring system known. The material of which the rings are made is more reflective than the material of other ring systems, suggesting that Saturn's rings are composed of icy rather than rocky particles. From the Earth, only two rings (A and B) and the gap between them (the Cassini division) are visible with a telescope.

FORMATION OF A RAY CRATER

Formed by the impacts of comets and meteorites (see pp. 522-523), craters are a feature of the surfaces of all known rocky bodies in the solar system. On planets or satellites that have volcanic activity, however, many of the craters are covered over as volcanic material

flows over the surface. Craters are also less common on planets with a thick atmosphere – most small objects burn up in the atmosphere and never hit the surface. The rate of crater formation was greater when there was more debris left over from the formation of the solar system.

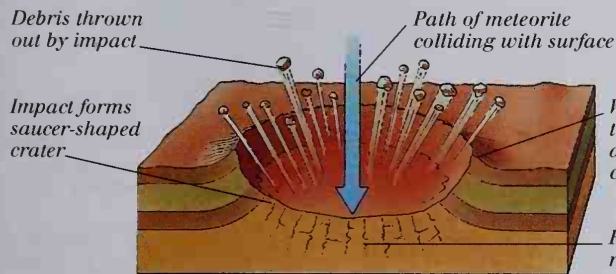

METEORITE IMPACT

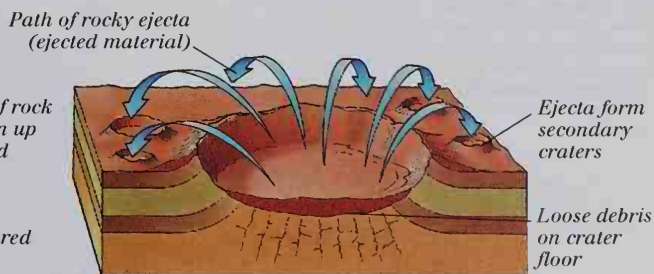

SECONDARY CRATERING



A RAY CRATER

The Moon

THE MOON IS THE SECOND BRIGHTEST object in the sky after the Sun (see pp. 306-307). It is the Earth's only natural satellite, and it is a cold, dry, and airless place. One side of the Moon – the “far side” – cannot be seen from the Earth and had never been observed before a Russian space probe took photographs of it in 1959. The Sun illuminates one half of the Moon at all times. The portion of this illuminated half that is visible from the Earth varies on a monthly cycle, giving rise to the lunar phases. When the Moon is between the Earth and the Sun, at new moon, we cannot see the illuminated side at all. At full moon, the Earth is between the Sun and the Moon, and the side of the Moon facing the Earth is fully illuminated. Occasionally, at full moon, the Moon passes through the shadow of the Earth, causing its surface to darken. This phenomenon is called a lunar eclipse. Perhaps the best known of the Moon's surface features are its craters, formed by meteorite impacts (see pp. 322-323) and dark “seas” called maria. Analysis of moon rock reveals that the Moon is made of igneous material, formed by the cooling of lava (see pp. 278-279).

HOW A LUNAR ECLIPSE OCCURS

The total phase of a lunar eclipse, when the Moon passes through the central part of the Earth's shadow (the umbra) lasts for up to an hour. During an eclipse, the Moon is not totally black, but appears reddish brown. This is because sunlight passing through the Earth's atmosphere is refracted so that some of it strikes the Moon. Most of the blue part of the spectrum is scattered by the atmosphere, leaving red light to reflect off the Moon.

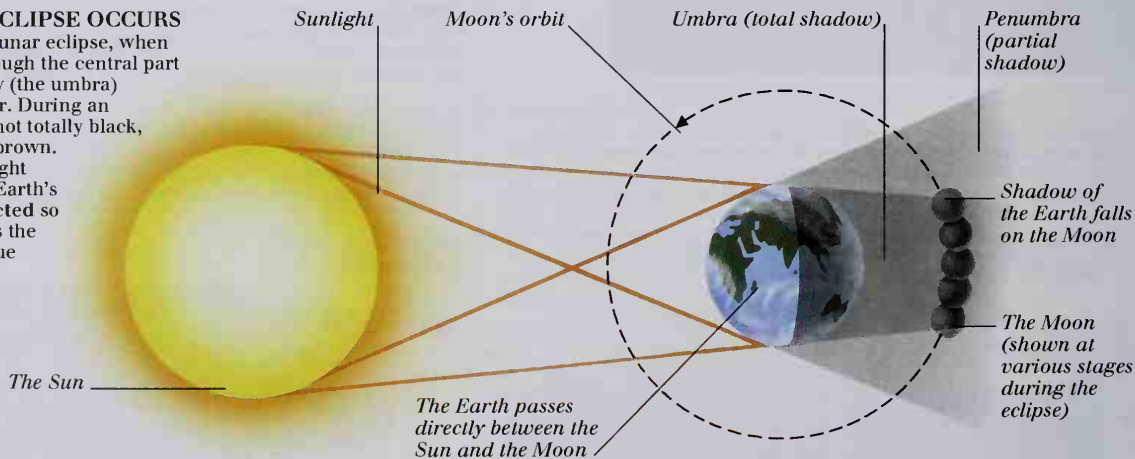

PHASES OF THE MOON

The Moon reflects light from the Sun and is the brightest object in the night sky. The amount of light it reflects varies as seen from the Earth. Once during every cycle, it reflects no light at all and is called a new moon. A few days after new moon, the Moon's near side becomes

visible, at first as a thin crescent. The proportion of the Moon's disk that we see increases (waxes) until, at full moon, the near side is completely illuminated. Over the next 14 days, the Moon's disk appears to decrease (wane), until the Moon once again lies between the Earth and the Sun.



MOON AT 4 DAYS

FULL MOON AT 14 DAYS

WANING MOON AT 19 DAYS

MOON AT 21 DAYS

MOON AT 24 DAYS

MOON DUST

The soil that covers the Moon's surface is called regolith and consists mainly of dust and rock fragments ejected during crater formation. Tiny, glassy particles called spherules are common in the lunar regolith. They are formed by the rapid heating and cooling that occurs as a result of meteorite impacts. The spherules below are about 0.025 mm in diameter.

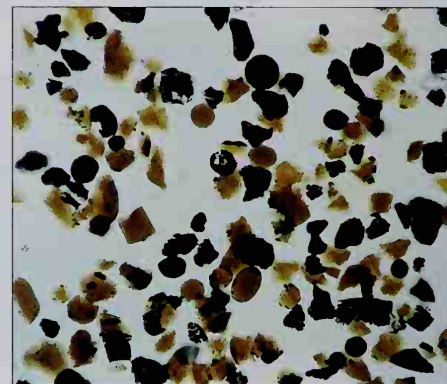

LUNAR SPHERULES

THE STRUCTURE OF THE MOON

The largest of the Moon's craters and maria are visible to the naked eye. The craters were formed by meteorite bombardment, which was much more frequent in the early solar system than it is now. The maria were created by intrusion of volcanic lava (see pp. 274-275) into large, ancient craters. They are more prevalent on the near side of the Moon, where the crust is thinner and intrusion is therefore more likely. From seismic analysis of moonquakes, it seems probable that the core is molten or at least semi-molten.

The Moon's diameter is 3,476 km, about one quarter that of the Earth's

FAR SIDE OF THE MOON

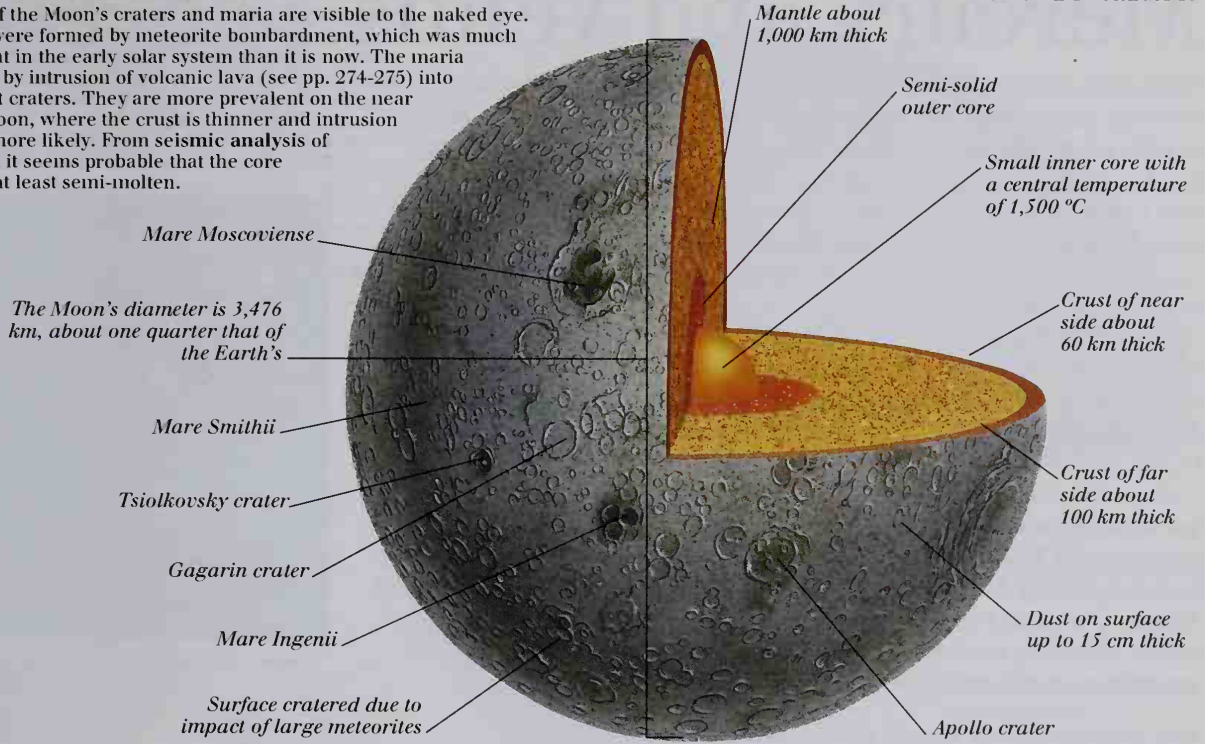

MOON FACTS

The Moon takes exactly as long to rotate on its axis as it does to revolve once around the Earth (27 days and 8 hours). This is why one side of the Moon is always hidden from the Earth. The orbit of the Moon is tilted to the ecliptic plane by about 5°. If it were not tilted to the ecliptic plane, a lunar eclipse would occur every full moon and a solar eclipse every new moon.

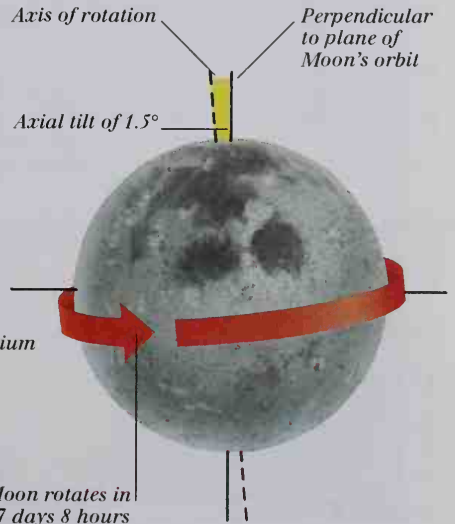

Mercury and Venus

MERCURY AND VENUS ARE THE TWO PLANETS closest to the Sun. Because their orbits are nearer to the Sun than the Earth's is, they exhibit phases like those of the Moon, when observed through an Earth-based telescope (see pp. 310-311). From the Earth, Mercury and Venus are visible only around sunrise or sunset. Venus is larger than Mercury, closer to the Earth, and usually at a greater elongation (apparent distance across the sky from the Sun). For these reasons, it is normally the brightest of the two. It is, in fact, the brightest object in the sky after the Sun and the Moon, and its prominence before sunrise or after sunset has led to it being called both the Morning Star and the Evening Star. Despite being so close in astronomical terms, Mercury and Venus are two very different worlds. The surface of Mercury is dry, rocky, and pock-marked with many craters, large and small. It is small – about the same size as the Moon – and has no atmosphere. Venus has a thick atmosphere and is about the same size as the Earth. Both planets have been visited by space probes (see pp. 302-303). Mercury was mapped by *Mariner 10* in 1974, while several probes have visited Venus. The most recent of these, *Magellan*, made extensive use of radar, allowing astronomers to penetrate its thick atmosphere and produce accurate maps of the planet's surface.

EARTH-BASED OBSERVATION

Mercury and Venus are close to the Sun in space, so they are never far from it in the sky. Each of the planets is visible to the naked eye – either just before sunrise or just after sunset – but Mercury is visible only when it is at its greatest elongation. Very occasionally, Mercury and Venus are seen to pass across the disk of the Sun, an occurrence called a transit.



Venus | Mercury | The Sun below the Earth's horizon

THE STRUCTURE OF MERCURY

Mercury's most obvious surface features are its millions of craters. Many of these are old, indicating that there has been no recent volcanic activity – which would otherwise have filled in some of the older craters with volcanic lava. Beneath the surface, Mercury is dominated by a huge, iron core. Its diameter is about 3,700 km: more than 75 percent of the diameter of the planet as a whole. Surrounding the core are a mantle and a crust. These are made of silicates, materials that are common in the mantle and crust of the Earth.

MERCURY FACTS

Mercury is almost exactly upright with respect to the ecliptic plane. The planet rotates on its axis exactly three times for every two complete orbits of the Sun. The planet's orbit is very eccentric. This, together with the planet's slow rotation and lack of atmosphere, leads to a huge variation in surface temperatures, which range from -183 °C to 427 °C.

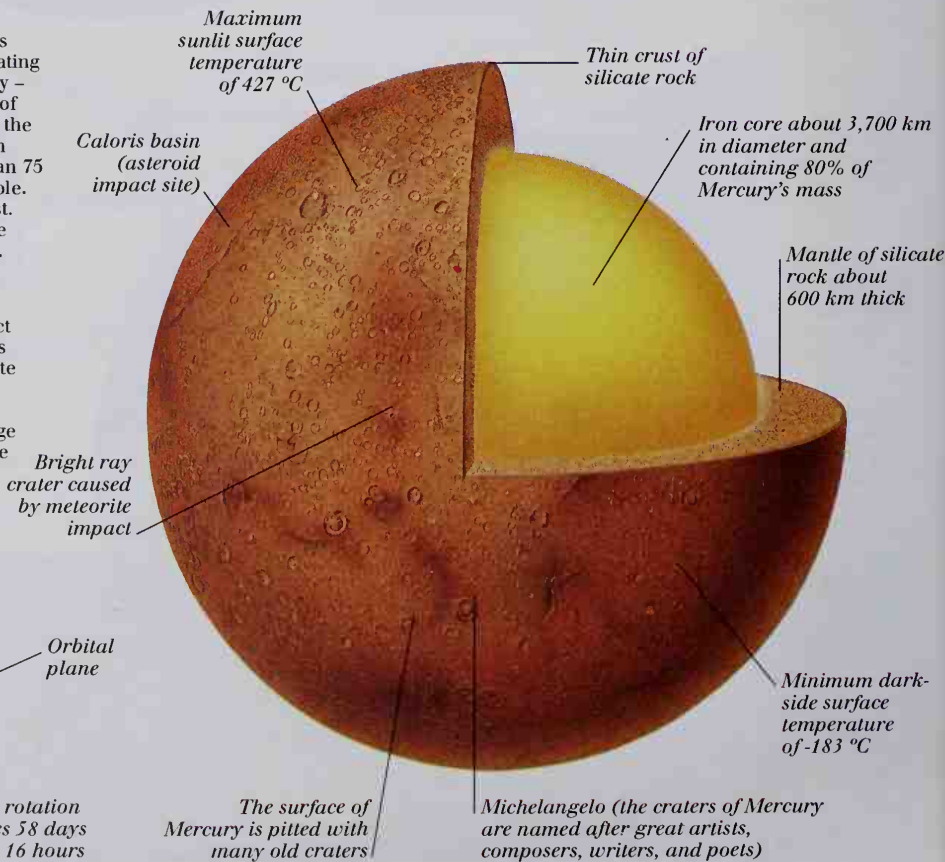
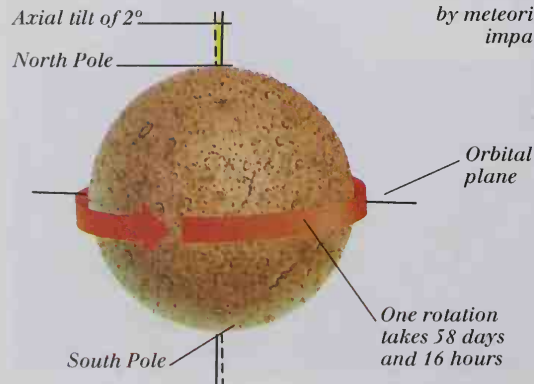

THE STRUCTURE OF VENUS

Venus and the Earth are alike in many respects. They have very similar **densities** and diameters. Volcanic activity is another common feature, and both planets have atmospheres that protect them from radiation and prevent the dramatic variations in surface temperature found on Mercury. Like the Earth, Venus has an iron core and a rocky mantle and crust. Unlike the Earth, however, the atmosphere of Venus is composed largely of carbon dioxide, with clouds of corrosive sulfuric acid. The abundance of carbon dioxide has led to a runaway **greenhouse effect**, giving rise to surface temperatures of up to 467 °C. The atmospheric pressure at the surface of Venus is around 90 times that of the Earth's.

VENUS FACTS

The axis of rotation of Venus is almost exactly 90° to the ecliptic. The rotation of Venus is retrograde (east-west). Most planets rotate counterclockwise as viewed from above their North poles. The planet rotates on its axis once every 243 days, and orbits the Sun once every 225 days, making its day longer than its year.

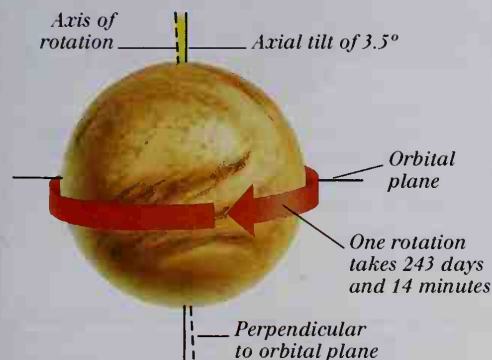

Maximum surface temperature of 467 °C

Mountainous region

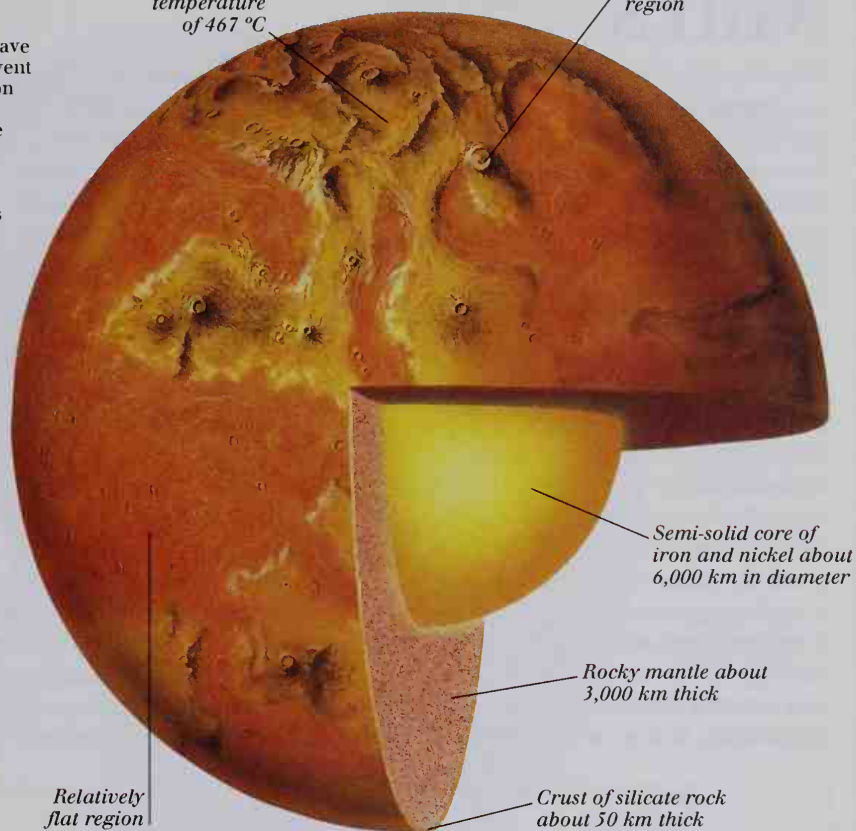

RADAR MAPPING THE SURFACE OF VENUS

The principle of radar mapping is very simple: bursts of microwave radiation are transmitted from a probe and reflect off the surface of the planet. From the time delay between transmission and reception of the reflected pulse, the height of the probe in relation to the planet's surface can be worked out with great accuracy. This

technique can map a planet's rocky terrain through thick clouds, and even under layers of dust. The *Magellan* probe (launched in May 1989 from the space shuttle) produced very accurate radar maps of the surface of Venus. Detailed three-dimensional computer models were created using the data gathered by the probe.

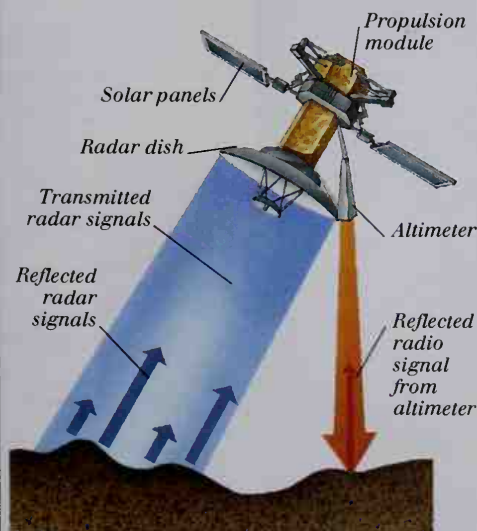

HOW A RADAR MAP IS CREATED



IMAGE OF THE SURFACE OF VENUS CREATED BY RADAR MAPPING

Mars

MARS IS THE FOURTH PLANET from the Sun. It is the outermost of the terrestrial planets and is separated from Jupiter (see pp. 316-317), the first of the gas giants, by the asteroid belt (see pp. 322-323). From the Earth, Mars is seen as a bright object that appears to move across the sky from night to night. Its two small moons, Phobos and Deimos, can easily be seen through a small telescope. Although the atmosphere on Mars is very thin by comparison with that on the Earth, dust storms are a common occurrence. The winds that cause the dust storms occur across the whole planet and change direction as the Martian seasons change. There are four seasons during the course of a Martian year, which lasts almost twice as long as a year on Earth. Mars has several enormous, extinct volcanoes, including Olympus Mons, the largest known volcano (see pp. 274-275) in the solar system. The surface is also scarred by a number of vast canyons, some of which are bigger than the Grand Canyon. The Martian surface is covered with a dust that contains a large proportion of the compound iron oxide, which gives the planet its distinctive red color. Beneath its surface, Mars has a cold, rocky crust and mantle, and a solid, iron core. During the 19th century, some astronomers observed what they assumed to be signs of intelligent life on the planet. These signs included canal-like markings and varying dark patches, which were thought to be areas under cultivation. It is now known that these assumptions were mistaken.

MARS FACTS

The tilt of Mars's axis is almost the same as the Earth's. As is the case on the Earth, this axial tilt is the cause of the planet's seasons. Mars rotates once on its axis every 24 hours and 37 minutes, which makes a Martian day about the same length as a day on the Earth.

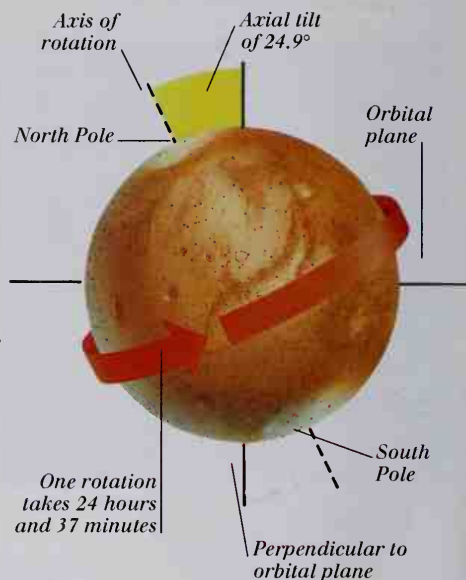

ORBIT OF MARS

Watched over a period of a few weeks, the apparent motion of Mars across the night sky sometimes follows several irregular loops. This is called retrograde motion and occurs, to a lesser extent, with other planets. The explanation of this phenomenon is that our vantage point, the Earth, moves more quickly through its orbit than does Mars, and therefore overtakes it.

At the time that this was first suggested, most people believed in the geocentric model of the universe (which puts a fixed Earth at the center of the universe). Observations of the actual motion of Mars helped to disprove this theory, placing the Sun at the center of the solar system.

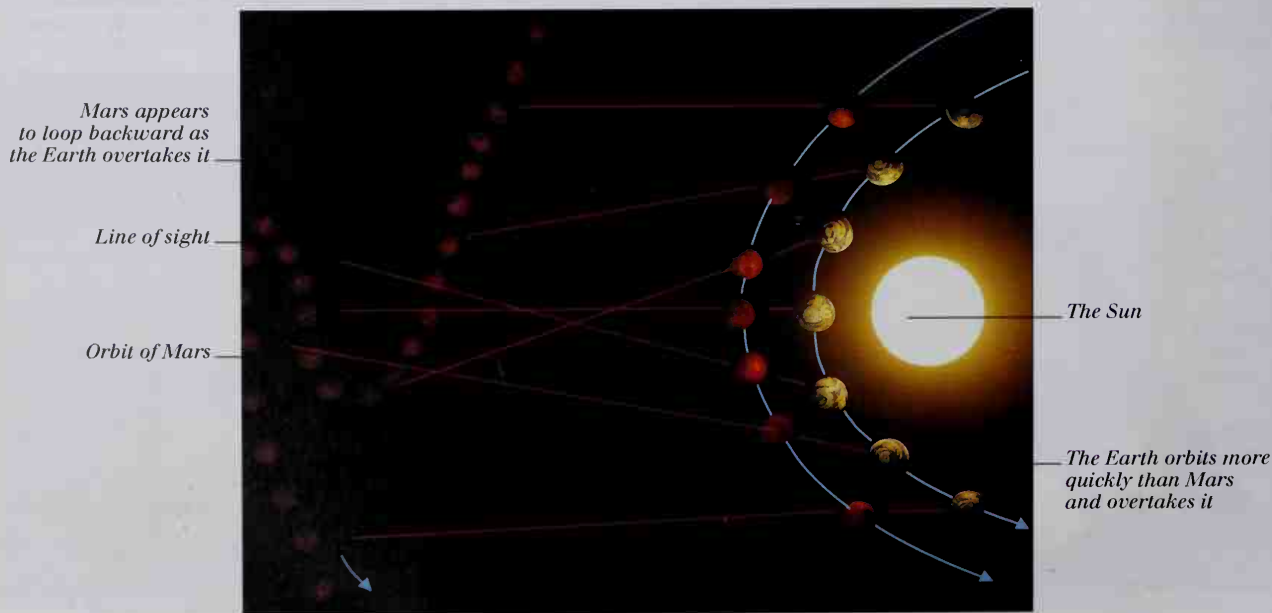

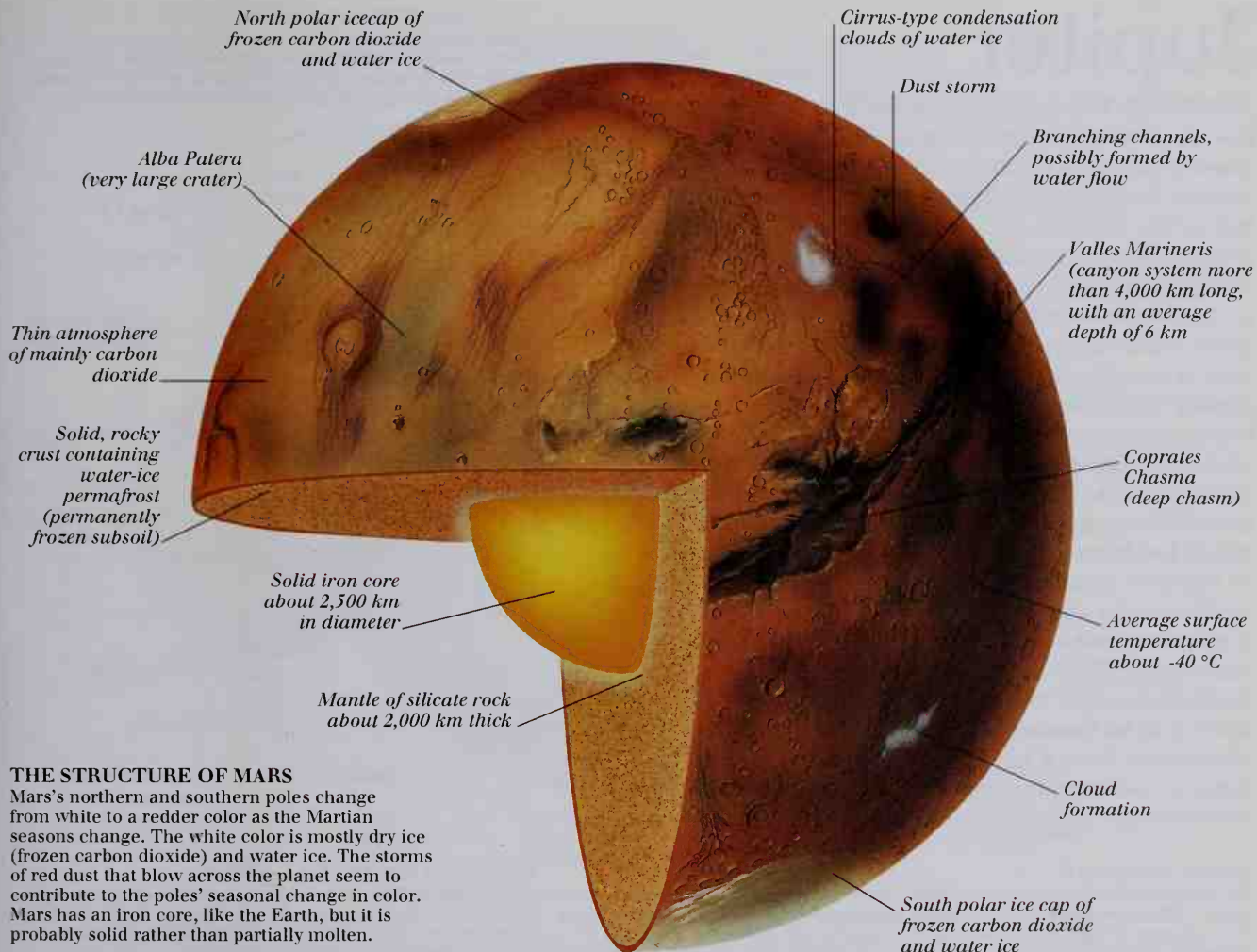

THE STRUCTURE OF MARS

Mars's northern and southern poles change from white to a redder color as the Martian seasons change. The white color is mostly dry ice (frozen carbon dioxide) and water ice. The storms of red dust that blow across the planet seem to contribute to the poles' seasonal change in color. Mars has an iron core, like the Earth, but it is probably solid rather than partially molten.

SURFACE FEATURES OF MARS

Mars has a heavily cratered surface that has remained unchanged for millions of years. There seems to be evidence of the flow of liquid water at some time in the past at many locations on the surface of Mars. For example, there are huge canyons that look like river valleys. There is no plate movement (see pp. 272-273) in the Martian crust, so

landscape features do not change for millions of years. The lack of plate movement also means that volcanoes on Mars are not carried away from the magma source. This may explain why Mars has some of the largest volcanoes in the solar system. These include Olympus Mons, which is 25 km high - three times higher than Mount Everest.



APPARENT FACE ON THE SURFACE OF MARS

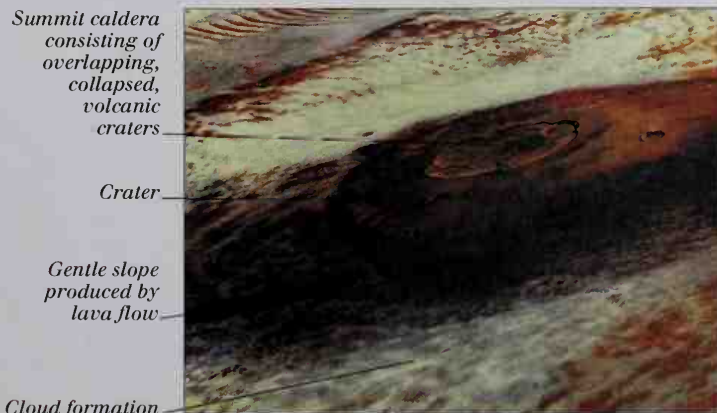

OLYMPUS MONS (EXTINCT SHIELD VOLCANO)

Jupiter

JUPITER IS THE LARGEST PLANET in the solar system (see pp. 304-305). Like Saturn (see pp. 318-319), Jupiter consists nearly exclusively of the elements hydrogen and helium. Its recognized diameter is more than eleven times that of the Earth's, and its mass is more than 300 times greater. Jupiter's rocky core is surrounded by metallic hydrogen (liquid hydrogen that behaves like a metal) and is very hot – around 30,000 °C. If the planet were about 75 times more massive, nuclear fusion (see pp. 58-59) would start at its core and it would become a star. Jupiter rotates rapidly on its axis, giving rise to a slight widening around its middle, known as its equatorial bulge. The banded structure of Jupiter's gaseous atmosphere is caused by this rapid rotation, as is the Great Red Spot, a high-pressure storm system that is more than twice the diameter of the Earth and which has been observed for over 300 years. The outer layers of Jupiter's atmosphere have been studied directly by the *Galileo* probe (see pp. 302-303). Jupiter is normally the fourth-brightest object in the sky – after the Sun, the Moon, and Venus. The planet's four principal moons – known as the Galilean moons – were the first moons, other than the Earth's, to be discovered. In July 1994, fragments of Comet Shoemaker-Levy 9 bombarded Jupiter in a historic series of impacts. Later analysis of the results of these impacts has revealed much about the planet.

GREAT RED SPOT

The Great Red Spot is a huge anticyclonic storm in the southern hemisphere of Jupiter. (White ovals are smaller, similar features of the planet's atmosphere.) The colors of the clouds in Jupiter's atmosphere vary depending on their altitudes. The lowest cloud layer is blue, followed by dark orange, and white. Red clouds, like those of the Great Red Spot, are highest. The different colors are associated with different chemical reactions in the atmosphere of the planet.

The Great Red Spot

The storm is 26,000 km long, more than twice the diameter of the Earth

White Oval (temporary anticyclonic storm system)



TILT AND ROTATION OF JUPITER

Jupiter takes just under 10 hours to rotate once on its axis. This is less than half the time it takes for the Earth to rotate on its axis. Matter around the equator travels more quickly than matter around the poles, giving rise to an equatorial bulge.

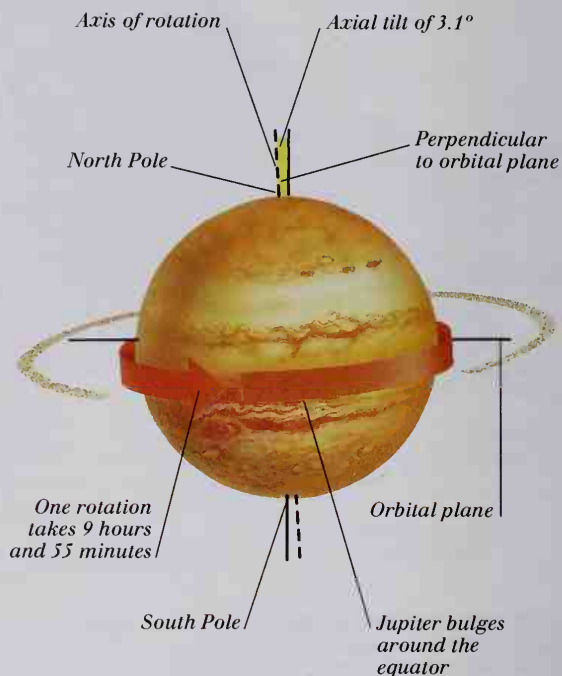

GALILEAN MOONS OF JUPITER

Jupiter has 16 known moons. Of these, four are large enough to be seen from the Earth through a small telescope or binoculars. These are the Galilean moons, named after their discoverer, the Italian astronomer Galileo Galilei (see pp. 394-395). Io, the innermost moon, is one of the few bodies in the solar system known to have active volcanoes.



EUROPA

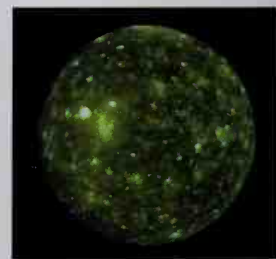

CALLISTO



GANYMEDE



IO

THE STRUCTURE OF JUPITER

Jupiter's rocky core is surrounded by an inner mantle of metallic hydrogen. This unusual form of hydrogen is found only in conditions of very high temperature and pressure. It is a dense "soup" of hydrogen nuclei and electrons that behaves like a metal. Jupiter's outer mantle is liquid and merges with the atmosphere.

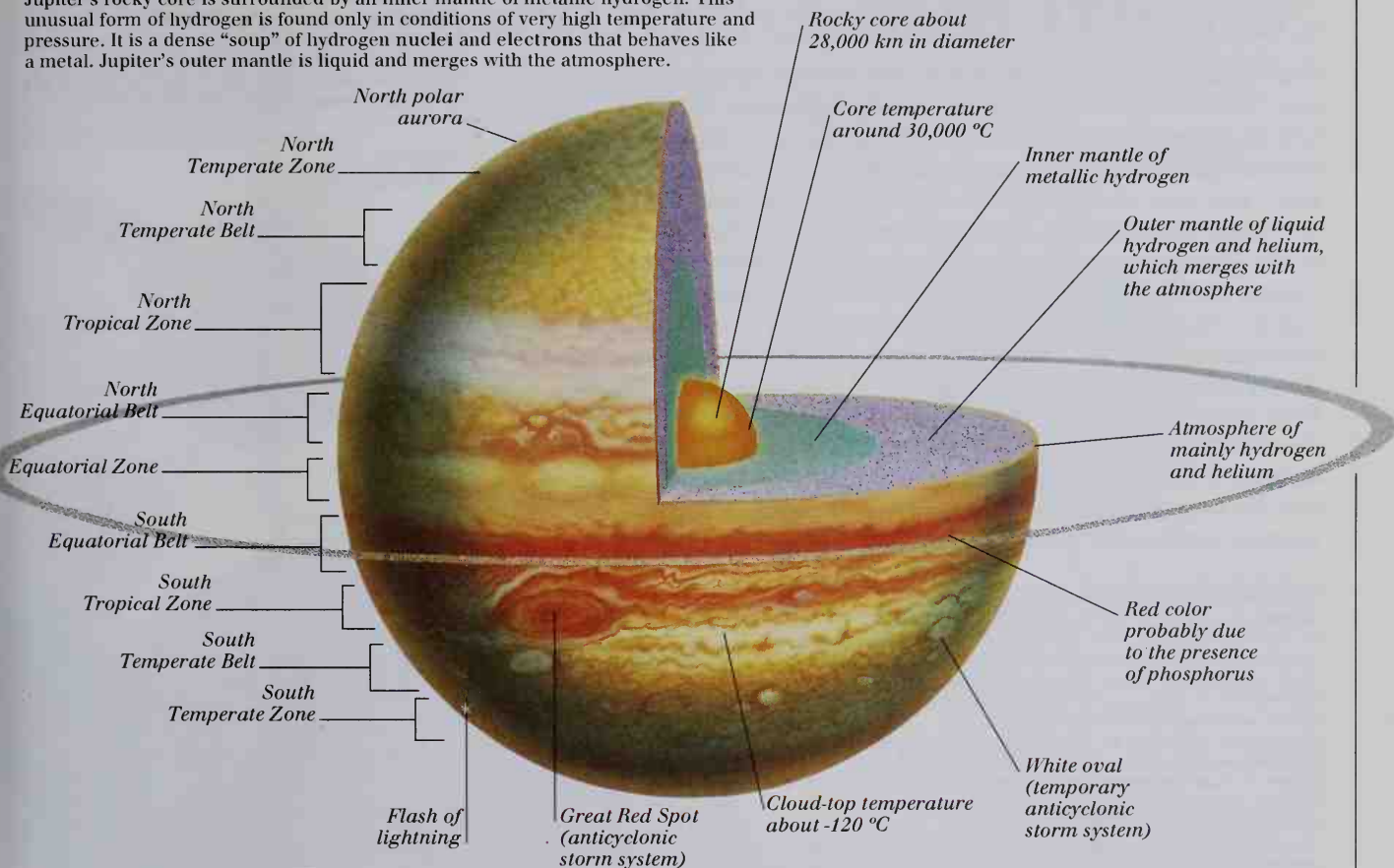

ATMOSPHERE OF JUPITER

Like all of the gas giants, Jupiter does not have a definite radius. Instead, it becomes gradually more dense with depth. Its radius is defined as the distance out from the center of the planet at which the atmospheric pressure is equal to atmospheric pressure at sea level on the Earth.



IMPACT OF COMET SHOEMAKER-LEVY 9 ON JUPITER

In July 1994, Comet Shoemaker-Levy 9 approached Jupiter. Tidal forces due to Jupiter's strong gravitational field broke the comet into a number of fragments. These fragments hit the planet one by one, over a period of six days. The results were spectacular, and the impacts left a series of "bruises" in the atmosphere. These were the result of violent explosions called fireballs, caused by the impacts of the cometary fragments.

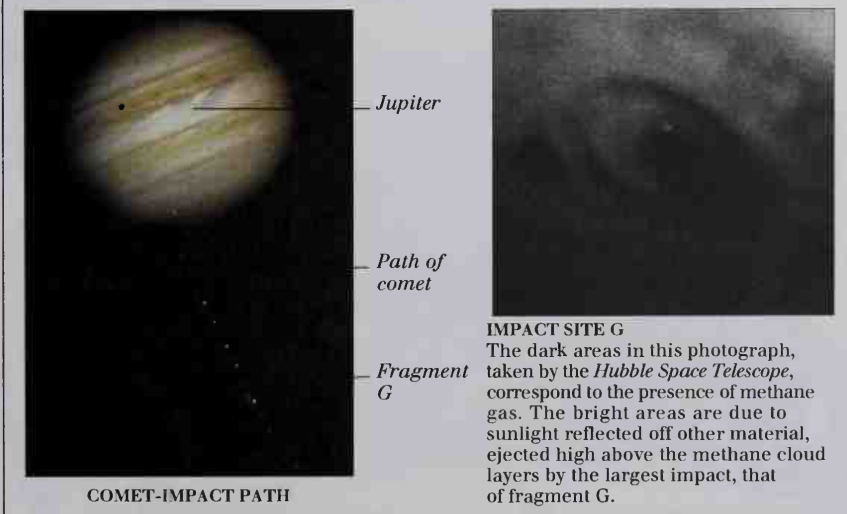

IMPACT SITE G
The dark areas in this photograph, taken by the *Hubble Space Telescope*, correspond to the presence of methane gas. The bright areas are due to sunlight reflected off other material, ejected high above the methane cloud layers by the largest impact, that of fragment G.

Saturn and Uranus

SATURN AND URANUS are the sixth and seventh planets out from the Sun. They are typical **gas giants**, consisting mainly of hydrogen and helium in liquid and gas forms. Both planets have **atmospheres** with banded structures, which are caused by rising and falling regions of gases and high winds that blow in alternate directions. These bands are barely noticeable on Uranus, largely because they are masked by the planet's uniformly blue-green upper atmosphere. Both planets have a ring system (see pp. 308-309). Saturn's ring system was first discovered in the 17th century, during early telescopic observations. It is the largest and most complex ring system of any planet in the solar system. In contrast, the rings around Uranus were discovered only as recently as 1977. Much of what we know about Saturn and Uranus was learned from data sent back by the *Voyager 2* space probe (see pp. 302-303), which visited both planets and discovered several moons. Saturn has eighteen moons – the greatest number for any planet – while Uranus has fifteen.

SATURN FACTS

Each revolution of Saturn around the Sun takes 29.5 Earth-years to complete. Saturn rotates rapidly on its axis. This rapid rotation causes an equatorial bulge similar to Jupiter's. The planet's axis of rotation is tilted with respect to the ecliptic by about the same angle as the Earth's is.

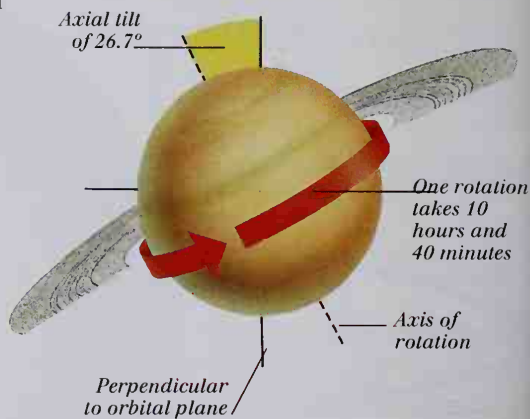

THE STRUCTURE OF SATURN

Saturn has a core of rock and ice that is surrounded by metallic hydrogen. The rest of the planet is composed mainly of hydrogen and helium, in liquid and gaseous forms. The planet's upper atmosphere contains a good deal of ammonia and its **compounds**. The overall **density** of Saturn is the lowest of all the planets. Saturn is less dense than water and so would float on a lake – if there were one large enough. It has the best-known and most spectacular ring system of all the gas giants. Mysterious dark lines in the ring system, called radial spokes, have been observed by the *Voyager* space probes.

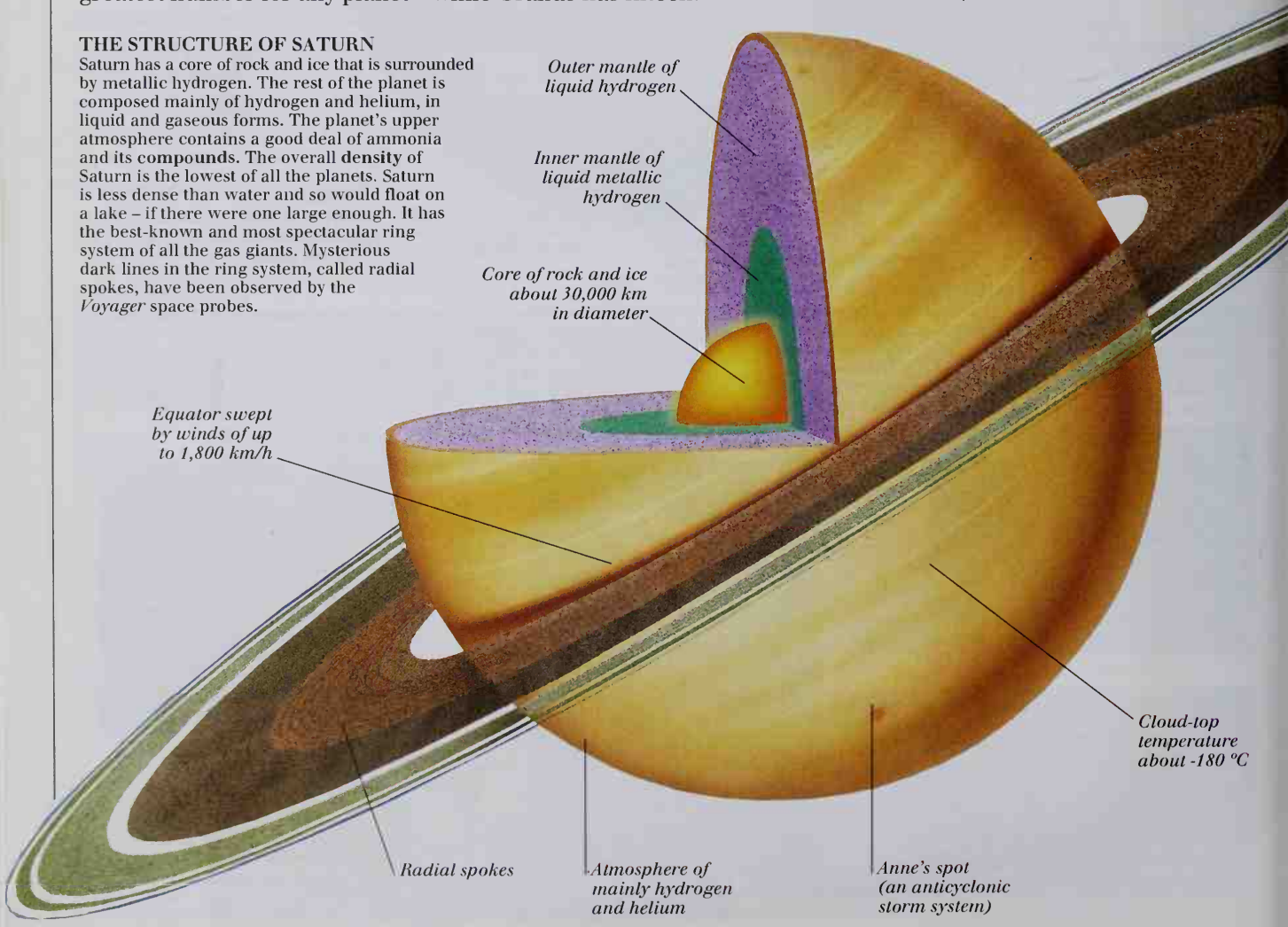

THE STRUCTURE OF URANUS

The blue-green color of the upper atmosphere of Uranus is due to a relatively high abundance of methane. (This **compound** absorbs red light, reflecting only blue and green light from the white light falling on it from the Sun.) The planet's rings were discovered during Earth-based observations of the planet as it occulted (passed in front of) a star. They are incomplete and nonuniform, which would seem to indicate that the ring system may be relatively young. (The ring system may be composed of fragments of a moon that was broken up by the gravitational influence of the planet.)

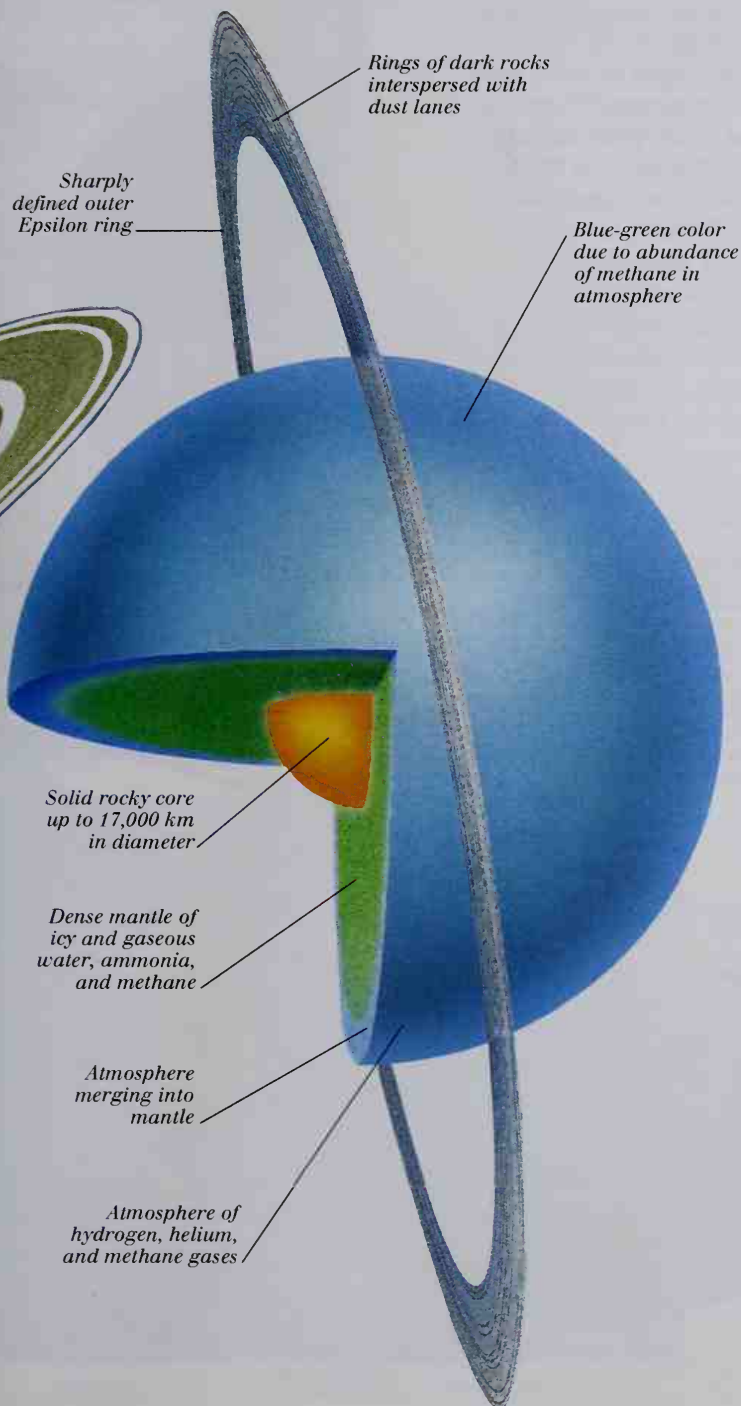

URANUS FACTS

Uranus has an 84-year orbit. It rotates as though it were on its side with respect to the **ecliptic plane**. As the planet revolves around the Sun, light shines first on to one pole, then the equator, then the other pole, then the equator once again. This is one reason why the planet shows little temperature difference throughout its atmosphere.

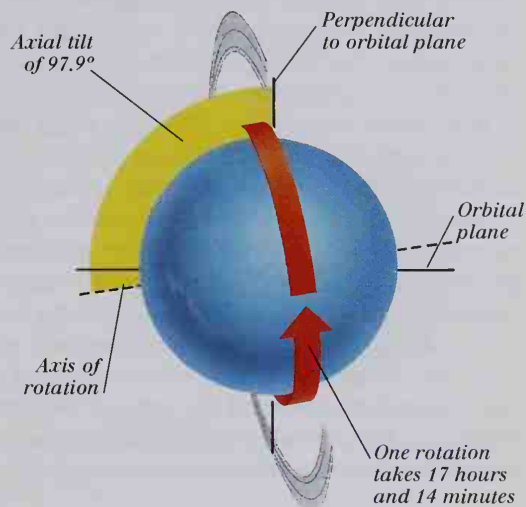

TECTONIC PLATES

Miranda is the most interesting of the outer moons of Uranus and is pictured here in a photograph taken by *Voyager 2* in 1986. Miranda's diameter is about 484 km – only one seventh the diameter of our moon – and it orbits Uranus at an average distance of 129,800 km. The scarred face of Miranda is covered not only with craters, but also with valleys, faults, and highland plateaus. All of these features suggest that the surface of Miranda, like that of the Earth, is composed of tectonic plates (see pp. 272-273).

Valleys and faults suggest tectonic activity



MIRANDA – A MOON OF URANUS

Neptune and Pluto

NEPTUNE IS THE OUTERMOST of the **gas giants**. Like Uranus (see pp. 318-19), its blue color is due to the presence of methane gas in its atmosphere. Neptune has eight known moons and a ring system (see pp. 308-309). Pluto is a small, rocky body with just one moon and no ring system. For most of its 248-year orbit, Pluto is the planet farthest from the Sun. However, it has a very **eccentric orbit**, which causes it to pass inside the orbit of Neptune. Pluto was discovered in 1930, after calculations based on deviations in the orbits of Uranus and Neptune prompted the search for the planet. Pluto's **mass** is not great enough to have caused these deviations, and so, after the discovery of Pluto, astronomers began a search for yet another planet. The hypothetical planet – called Planet X – was never found. Recent, more accurate, measurements of the masses of Neptune and Pluto show that the orbital deviations of Uranus and Neptune are not caused by Planet X. They are, in fact, caused by other objects of a similar size to Pluto that have been found beyond the orbit of Neptune. These objects – called **Plutinos** – are probably similar to asteroids (see pp. 322-323), and are found in a region of the outer solar system called the Kuiper Belt.

THE STRUCTURE OF NEPTUNE

Most of what is known about Neptune was discovered during its encounter with the space probe *Voyager 2* in August 1989. Neptune is a typical gas giant, being composed mainly of hydrogen and helium, with methane and ammonia also present. It has a rocky core and its mantle is composed largely of various types of ice, including water. The icy mantle merges gradually into the gaseous atmosphere. *Voyager 2* sent back stunning pictures of the rings of Neptune, about which little was previously known. It is still not known for certain what the rings are composed of, but they probably consist of small chunks of rock and ice.

NEPTUNE FACTS

Neptune's orbit takes just under 165 Earth-years to complete. The planet rotates more rapidly on its axis than does the Earth. This rapid rotation, together with an axial tilt of nearly 29°, causes strong winds in Neptune's atmosphere. The planet's diameter is nearly four times as large as the Earth's.

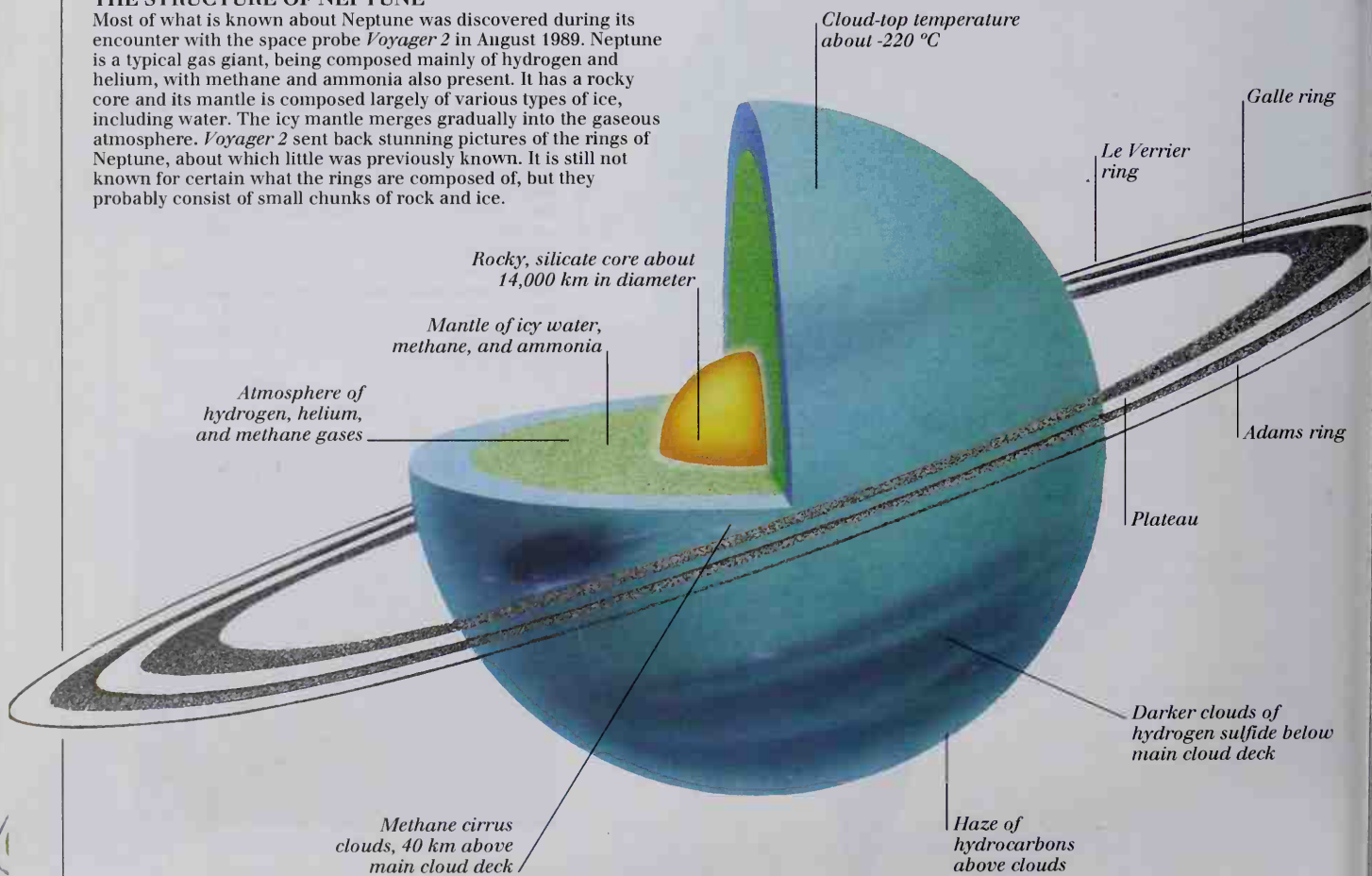
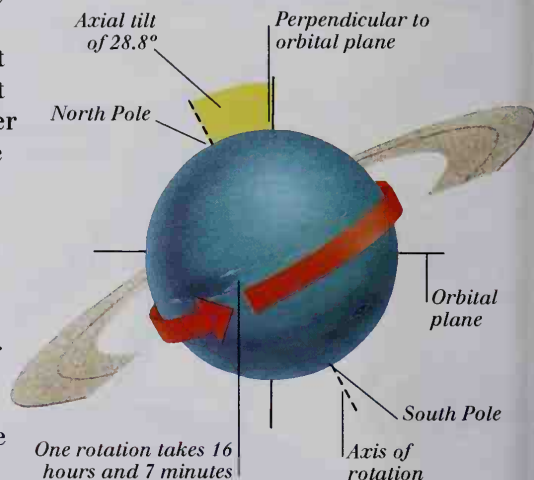

THE STRUCTURE OF PLUTO

The composition of Pluto is unknown. The density of the planet, calculated from its mass and its size, suggests that it consists largely of rock and water ice. Most of what is known of the structure of Pluto is computed from the spectrum of sunlight reflected off the planet. The planet appears to have a thin atmosphere, which may exist only when Pluto is near **perihelion** (its closest approach to the Sun). When the planet is farther from the Sun, its surface temperature falls, and the atmosphere probably freezes.

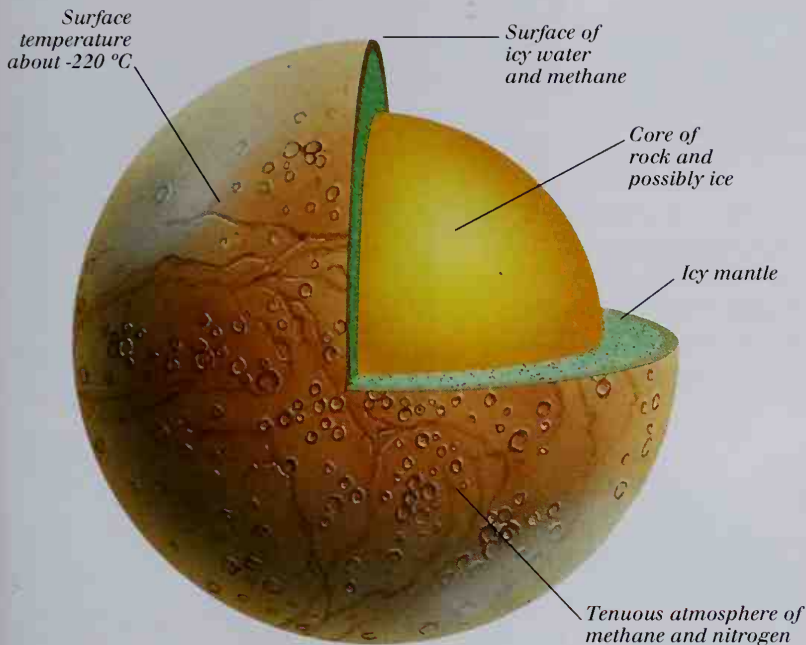

PLUTINOS

Beyond the orbit of Neptune lies the Kuiper Belt, a collection of rocky bodies similar to asteroids. Some astronomers consider Pluto to be a Kuiper Belt object rather than a true planet. It takes exactly one-and-a-half times as long as Neptune to orbit the Sun (a ratio of 3 to 2). This is known as 3:2 orbital resonance, and several recently discovered Kuiper Belt objects (called Plutinos) share this property. Further weight is given to the argument that Pluto is not a true planet by the fact that Pluto's orbit is inclined steeply to the **ecliptic plane**.

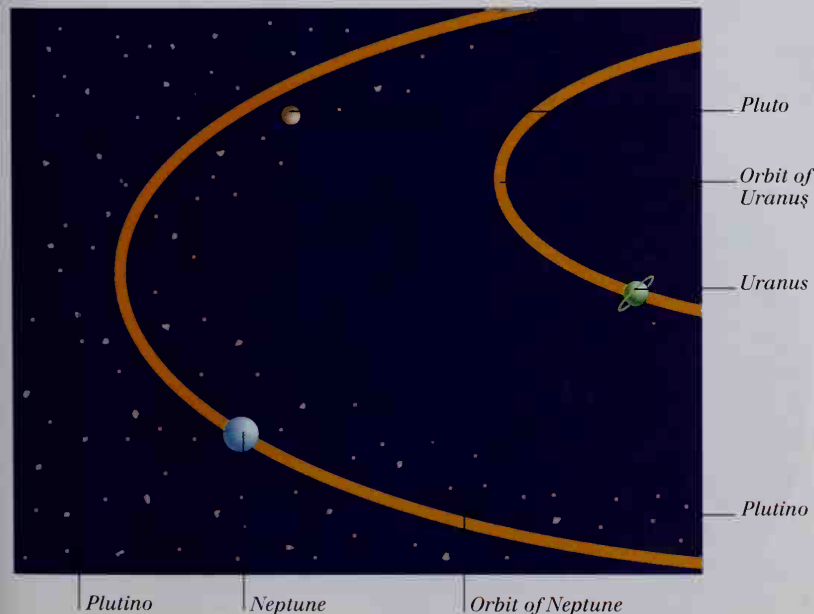

PLUTO FACTS

Pluto orbits the Sun at an average distance of 5,900 million km. This is nearly 40 times greater than the average distance of the Earth from the Sun, or nearly 40 **astronomical units**. At this distance, Pluto must be a very cold and dark world. It is actually smaller than several of the moons orbiting some of the other planets in the solar system.

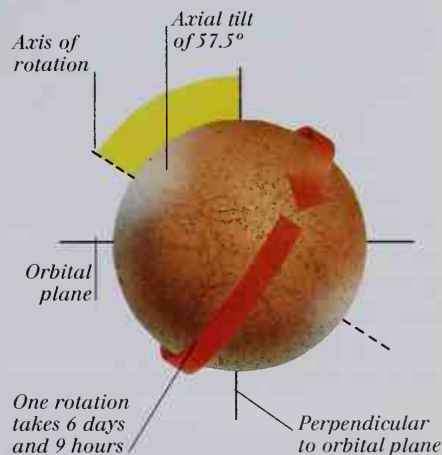

DOUBLE-PLANET SYSTEM

Pluto and its satellite, Charon, are often considered to be a double-planet system because their masses are so similar. Using Earth-based telescopes, it is almost impossible to figure out the relative masses of the two planets, which will not be known for certain until a space probe travels close to the system.

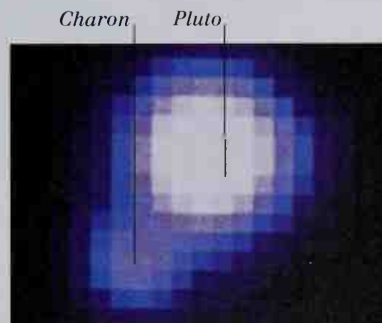

USUAL VIEW FROM EARTH



HUBBLE TELESCOPE IMAGE

Comets, asteroids, and meteoroids

COMETS ARE SMALL BODIES consisting mainly of dust and various ices. As a comet approaches the Sun (see pp. 306-307), it warms up, releasing huge amounts of gas and dust, which form long tails. Short-period comets are always within the orbits of the planets, but the majority of comets spend most of their time outside the orbit of Pluto (see pp. 320-321). Asteroids are rocky bodies up to 1,000 kilometers in diameter. Most of them are found in the asteroid belt, which lies between the orbits of Mars (see pp. 314-315) and Jupiter (pp. 316-317). Meteoroids are mostly fragments of asteroids or are debris left behind by the dust tail of a comet. As they enter the Earth's atmosphere, they heat up due to air resistance, appearing as bright, fast-moving streaks called meteors. Meteor showers occur when the Earth passes through the trail of dust particles left by a comet.

OBSERVING A COMET

A bright comet can be a spectacular sight, even to the naked eye. It looks like a bright, fuzzy star and has a long tail that points away from the Sun. Comets are visible to the naked eye only while they are relatively close to the Sun. A photographic exposure taken over a period of a few minutes (as shown below) allows astronomers to record the full glory of a comet.



TAILS OF A COMET

When they are near the Sun, comets have two tails: a straight gas tail and a curved dust tail. The gas tail forms as frozen material **sublimes**. A stream of fast-moving particles emitted by the Sun (the solar wind) pushes the gas tail into a straight line. As the frozen material sublimates, it releases dust from the comet's nucleus. The dust is pushed less easily by the solar wind, so it is left behind as a trail of debris along the curve of the comet's orbit.

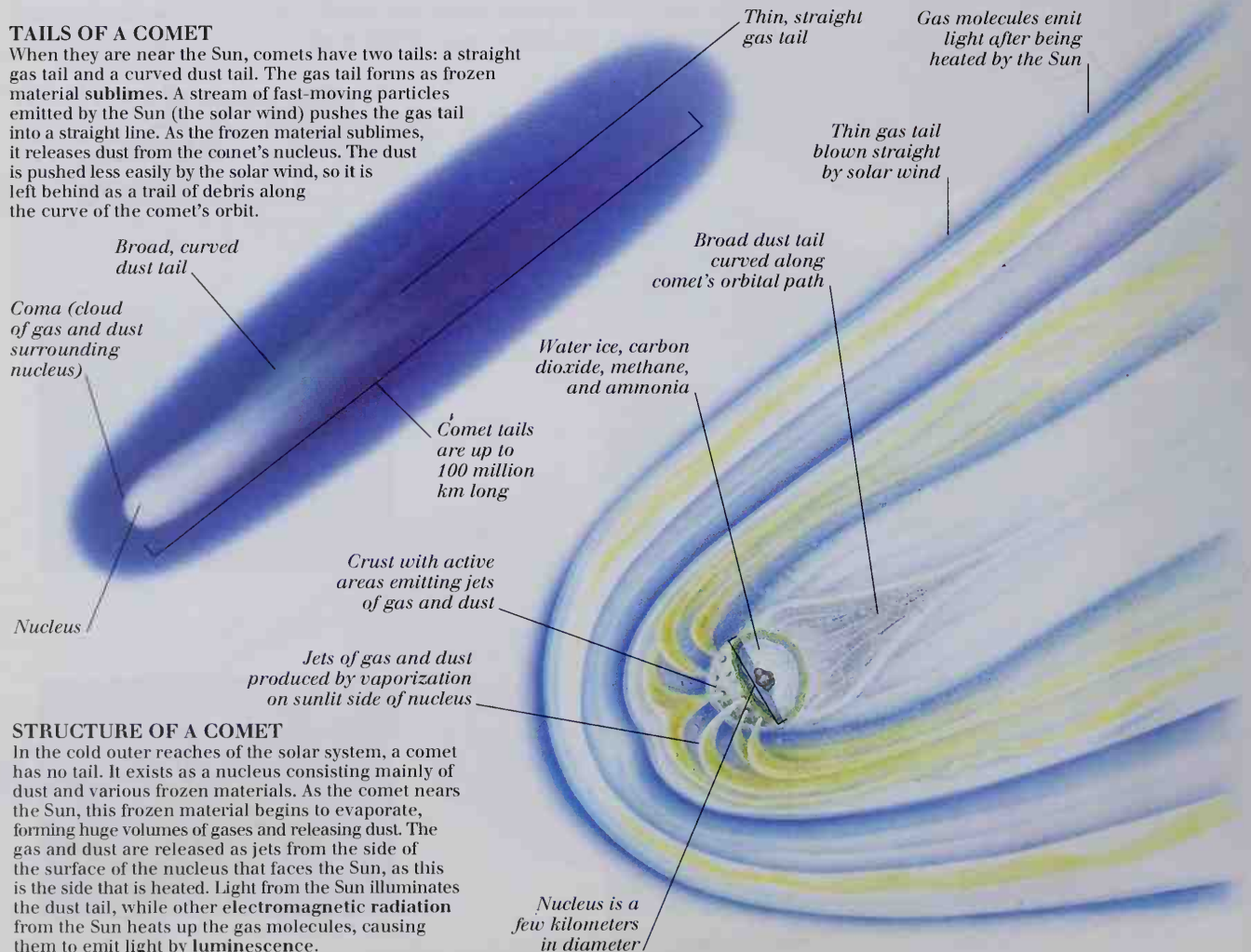

STRUCTURE OF A COMET

In the cold outer reaches of the solar system, a comet has no tail. It exists as a nucleus consisting mainly of dust and various frozen materials. As the comet nears the Sun, this frozen material begins to evaporate, forming huge volumes of gases and releasing dust. The gas and dust are released as jets from the side of the surface of the nucleus that faces the Sun, as this is the side that is heated. Light from the Sun illuminates the dust tail, while other **electromagnetic radiation** from the Sun heats up the gas molecules, causing them to emit light by luminescence.

ASTEROIDS AND THE ASTEROID BELT



ASTEROIDS

There are probably only about 200 asteroids with diameters greater than 100 km. The rest are smaller bodies, with an average diameter of about 1 km. Asteroid 243 (shown above) is a typical asteroid – small, irregularly shaped, and cratered.

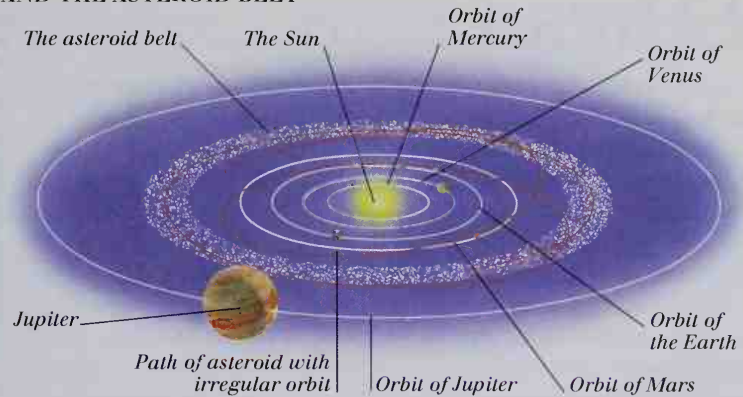

THE ASTEROID BELT

The asteroid belt probably formed at the same time as the planets, and one theory suggests that it may have been a failed planet, which was prevented from forming due to the gravitational influence of Jupiter. Some asteroids have irregular orbits and can approach dangerously close to the Earth.

METEORIODS AND METEOR SHOWERS



METEORIODS

As a meteoroid encounters the Earth's atmosphere, it appears as a bright streak called a meteor. Air resistance can vaporize a small meteoroid in just a few seconds. Meteoroids that survive their journey through the atmosphere are called meteorites.

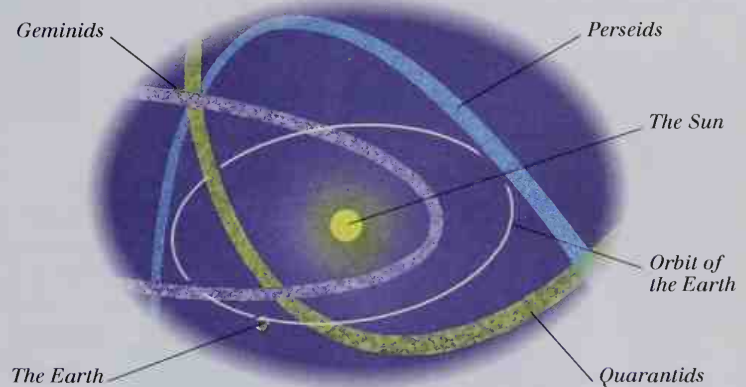

PATHS OF METEOR SHOWERS

A comet passing near to the Sun sheds dust. As the Earth passes through this dust it is "showered" with meteors. These showers occur annually and appear to radiate from particular points in the sky. For example, the Geminids meteor shower (December 7 and 16) appears to radiate from the constellation Gemini.

NO ATMOSPHERE

The Moon's surface is pitted with numerous craters, great and small. There are far more craters on the surface of the Moon than on the Earth. This is because, unlike the Earth, the Moon has no atmosphere, so even the smallest meteoroids are able to strike the surface rather than burn up before a collision occurs.

Large crater

Small crater

South polar region of the Moon

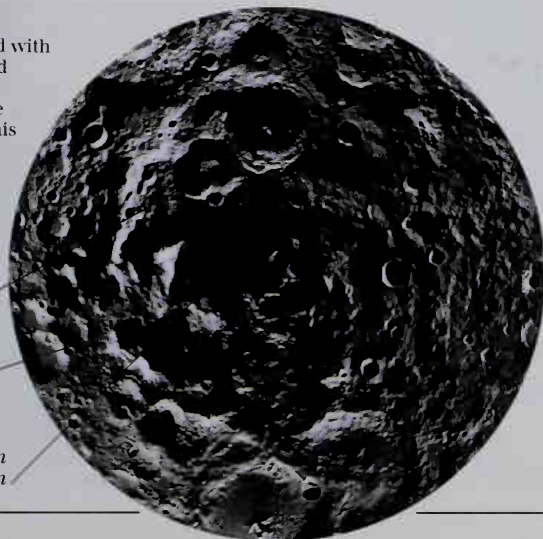

LIFE FROM MARS?

Some meteorites consist of material ejected during crater formation on other planets (see pp. 308-309). One such meteorite found on the Earth (named ALH84001) has been shown to have originated from Mars. It contained several of the chemicals vital for life to occur. Objects resembling cells were also found.



Stars

STARS ARE HUGE BALLS OF GLOWING GAS that are created in **nebulae** (see pp. 326-327). Groups of stars that are created in the same nebula form clusters. There are around 6,000 stars that are visible to the naked eye, and they all belong to the Milky Way Galaxy (see pp. 328-329). These stars are named according to the constellations in which they appear. The **absolute magnitude** of a star (see pp. 300-301) depends upon its **luminosity**, while its surface temperature can be determined from observations of its color. Absolute magnitudes and surface temperatures are plotted on a graph called the **Hertzsprung–Russell diagram**, and the size of a star can be estimated from its position on the diagram. Some stars have one or more companion stars relatively close by. This arrangement is called a **binary system**. An **eclipsing-binary system** is one in which a star passes in front of its brighter partner. An **eclipsing binary** is an example of a **variable star**, because its **apparent magnitude** varies periodically.

CONSTELLATION OF ORION

In ancient times, astronomers divided the sky into distinct groups of stars called constellations. Although stars in the same constellation appear close to each other in the sky, they are rarely close to one another in space. The main stars of the constellation of Orion, for example, are between 70 light years and 2,500 light years distant.

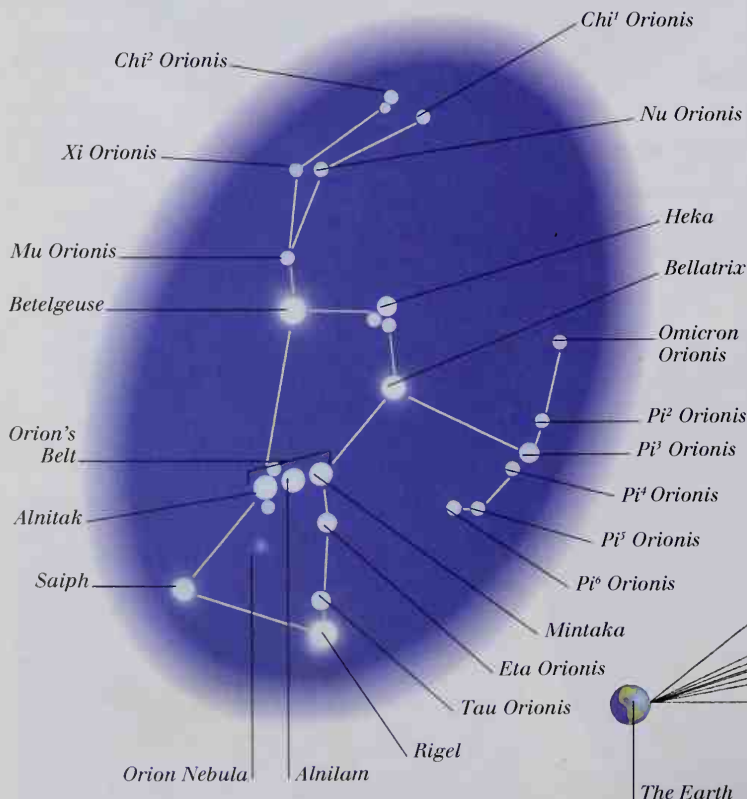

GLOBULAR CLUSTER

Globular clusters contain hundreds of thousands of stars and are held together by mutual gravitational attraction. They are nearly spherical in shape and appear as hazy blobs when viewed through a small telescope. Globular clusters are more tightly packed toward their centers and contain relatively old stars.



Central region containing old stars

Less densely packed region

OPEN CLUSTER

Open clusters normally contain only a few hundred stars. Most of the stars in an open cluster are hot and young and are within 10 parsecs (32.6 light years) of each other. The Pleiades (or Seven Sisters) is an open cluster that is visible to the naked eye.



Wisps of dust and hydrogen gas remaining from cloud in which stars formed

Young star in an open cluster of 300–500 stars

THREE-DIMENSIONAL VIEW OF THE CONSTELLATION OF ORION

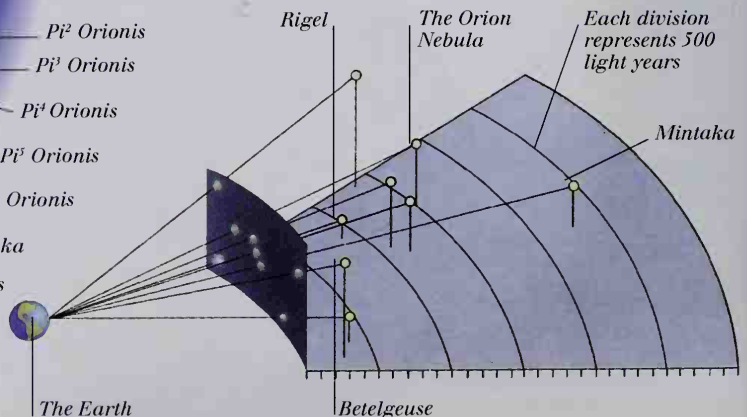

HERTZSPRUNG-RUSSELL DIAGRAM

It is possible to gauge the temperature of a star from its color. (The hottest stars are blue and the coolest stars are red.) Stars can be grouped into "spectral types" according to their colors and temperatures. The Hertzsprung-Russell diagram plots a star's spectral type against its absolute magnitude. The brightest stars are at the top of the diagram, and the dimmest are near the bottom. The hottest stars are to the left of the diagram and the coolest to the right. This simple relationship appears as a diagonal band across the diagram and is called the **main sequence**. Most stars spend some part of their lives in the main sequence. Giant stars are found above the main sequence and dwarf stars below.

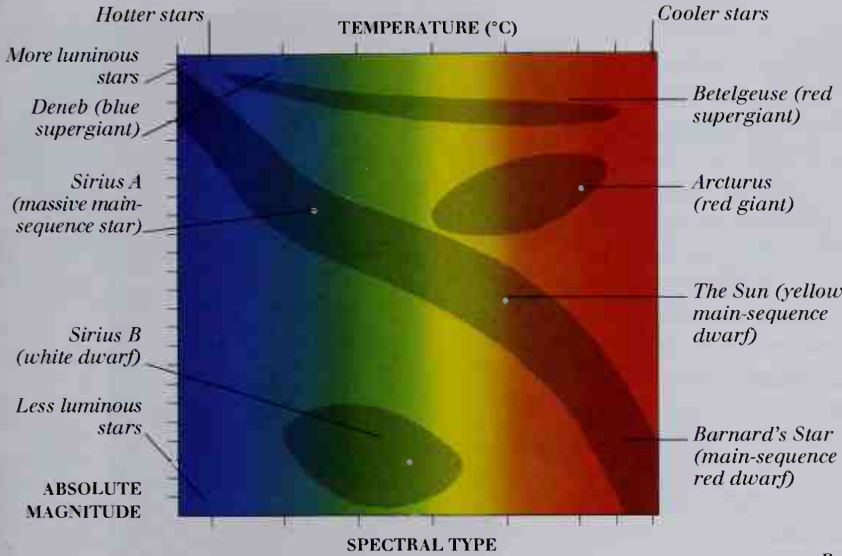

STAR MASSES

Stars fall into specific regions of the Hertzsprung-Russell diagram according to their sizes. All stars on the main sequence – including the Sun – are called dwarf stars. Toward the end of its lifetime, a star the size of the Sun swells to become a red giant and is then found at the upper right on the diagram. Larger stars become supergiants at this stage. At a later stage, they shrink to become white dwarfs, found below and to the left of the main sequence on the Hertzsprung-Russell diagram.

White dwarf (diameters between about 3,000 km and 50,000 km)

The Sun (main-sequence star with diameter of about 1.4 million km)

Red Giant (diameters between 15 million km and 150 million km)

VARIABLE STARS

The amount of light that reaches us from many of the stars in the night sky is variable. The periodic fluctuations in the magnitude of these variable stars can be plotted on a graph, and the resulting line is called a light curve. When two or more stars are orbiting the same center of gravity, they are said to form a binary or double-star system. In some cases, two stars periodically eclipse each other, as seen from the Earth. This causes

characteristic dips in the light curve of the system. The fluctuations in magnitude of most variable stars are caused by real changes in the stars' luminosities. In one important class of variable stars, called Cepheid variables, a relationship exists between the period of variation of a star's light curve and the absolute magnitude of the star. Astronomers can work out a star's distance from the Earth by comparing the star's absolute magnitude to its apparent magnitude.

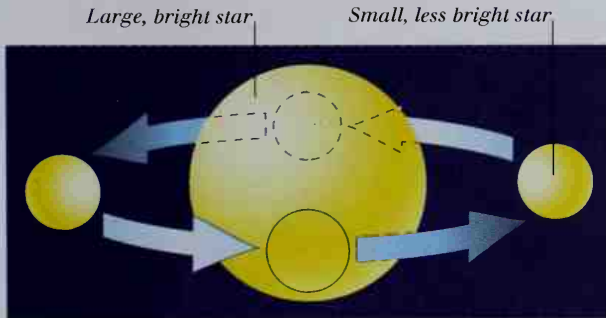

LIGHT CURVE OF AN ECLIPSING BINARY STAR

System at full brightness when stars do not eclipse each other

Light from smaller star is obscured as it passes behind larger star

Some light from larger star is blocked by smaller star

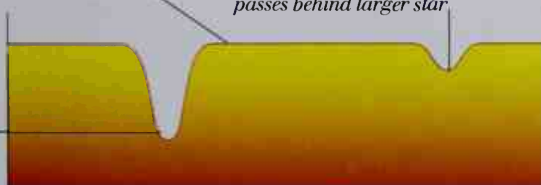

LIGHT CURVE OF AN ECLIPSING-BINARY STAR

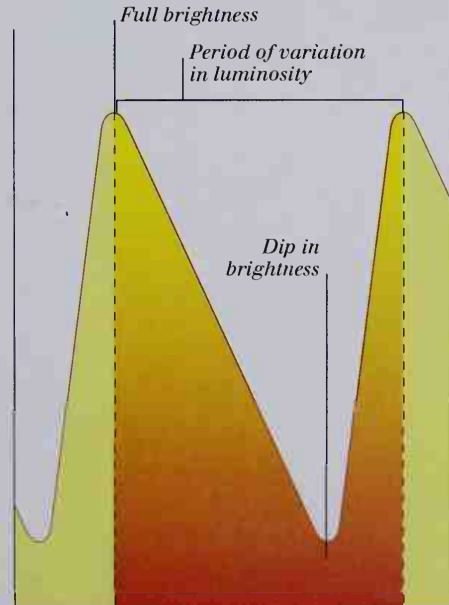

LIGHT CURVE OF A CEPHEID-VARIABLE STAR

Stellar life cycles

STARS EXIST FOR HUNDREDS OF MILLIONS or even billions of years. Although astronomers will never be able to observe the complete life cycle of a star, they have developed theories of stellar evolution based on observations of stars of all ages. New stars are created from gas and dust in the space between existing stars. This interstellar matter is denser in some regions – called **nebulae** – than in others. There are five types of nebulae: emission nebulae; reflection nebulae; dark nebulae; planetary nebulae; and supernova remnants. The first three of these are where stars are “born,” initially as protostars. A protostar becomes a star when **nuclear fusion** starts making helium from the hydrogen at its core. The course and duration of a star’s life cycle depends upon its **mass**. All stars shine relatively steadily until the fusion of hydrogen into helium ceases. This can take billions of years in a small star, but may last only a few million years in massive stars – where the rate of conversion is so much greater. Planetary nebulae are the result of the deaths of small stars like the Sun (see pp. 306-307). More massive stars explode in extremely energetic explosions called **supernovae**. Supernova remnants consist of gas thrown off during a supernova. The remaining core of a massive star may become a neutron star or a black hole (see pp. 330-331).

REGION OF STAR FORMATION IN ORION
Gravity causes the contraction of interstellar matter inside a nebula, such as this one in the constellation of Orion. The nebula heats up as it contracts, and it may glow. Dense regions within the nebula contract further to form protostars. As a protostar collapses, its temperature may rise high enough for nuclear fusion reactions to begin at its core. At this stage it becomes a true star and is said to be in its **main sequence**.



HORSEHEAD NEBULA

The Horsehead Nebula is a feature of the constellation of Orion, which contains examples of emission nebulae, reflection nebulae, and dark nebulae, as well as many bright, young stars. Emission nebulae glow as a result of the contracting gas, and protostars, contained within them.

In many regions, a nebula’s gas and dust may not yet have contracted enough to begin to glow. Where this type of nebula reflects light from nearby stars, it is called a reflection nebula. If it obscures light from stars beyond it (thereby appearing as a dark patch), it is called a dark nebula.



LIFE CYCLES OF SMALL AND MASSIVE STARS

When the hydrogen "fuel" of a main-sequence star begins to run out, the production of energy at the star's core is no longer sufficient to prevent further gravitational contraction. At this point the star collapses, and its temperature rises enough for elements such as carbon to be "cooked" by fusion reactions. The star then becomes

a red giant or red supergiant, depending on its mass. A red giant develops into a planetary nebula and eventually a cold, white dwarf. A red supergiant undergoes rapid collapse - which takes less than a second. This causes a huge explosion, called a supernova. The remnants of a supernova may include a neutron star or a black hole.

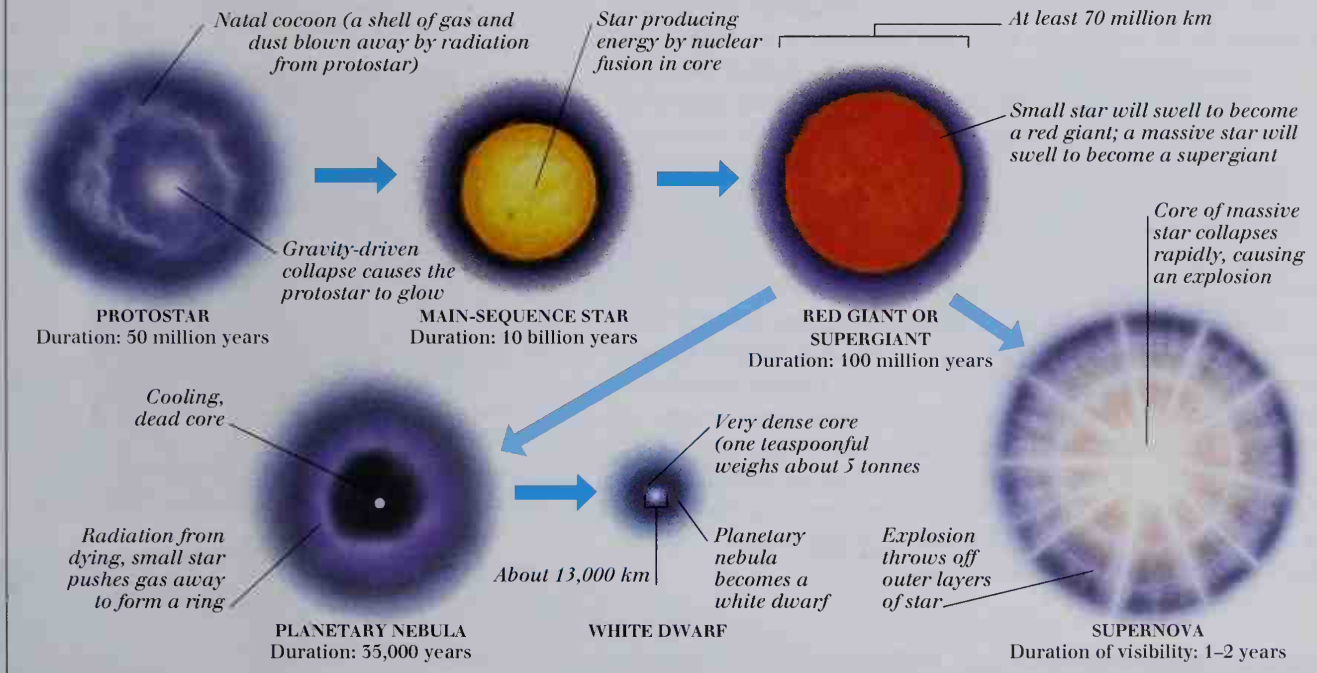

HOURGLASS NEBULA

After about 100 million years as a red giant, a small star will collapse once more due to the force of gravity. Nuclear reactions begin again, and the star swells and pushes away its outer layers into a ring. The matter in these layers glows by fluorescence, as it is illuminated by ultraviolet light from the star.



Planetary nebula (gas shell expanding from dying core)

Stellar-core temperature about 100,000 °C

Blue-green light from hot, ionized oxygen and nitrogen gases

Red light mainly produced by fluorescence

VELA SUPERNOVA REMNANT

When the core of a supergiant undergoes gravitational collapse, it contracts rapidly before "bouncing" back, throwing off its outer layers in an explosion called a supernova. The debris is strewn around space as a type of nebula called a supernova remnant.



Supernova remnant (outer layers of star thrown off in explosion)

Green light from nitrogen and oxygen

Filament of ionized hydrogen gas

Galaxies

A GALAXY IS A HUGE SYSTEM of stars and interstellar gas, all of which are held together by the forces of **gravity** they exert on one another (see pp. 22-23). There are about 100 billion galaxies in the universe. They are grouped in clusters, which are themselves grouped into superclusters. Before galaxies were even recognized as such, a number of them had been listed – together with nebulae and other objects – in a catalog created by the French astronomer Charles Messier (1730-1817). Many galaxies are therefore denoted by the letter “M” followed by a number. A more comprehensive list is the New General Catalog, where all known galaxies are given an NGC number. In 1926, the American astronomer Edwin Hubble (1889-1953) categorized all of the known galaxies into four basic types – irregular, elliptical, spiral, and barred spiral – according to their shape. Another type of galaxy, called a **quasar** (the name stands for *quasi*-stellar objects), was discovered in 1960. Although these galaxies are very bright, they are not well understood because they lie billions of light years from the Earth. The solar system (pp. 304-305) is situated inside one arm of a spiral galaxy called the Milky Way Galaxy.

TYPES OF GALAXIES

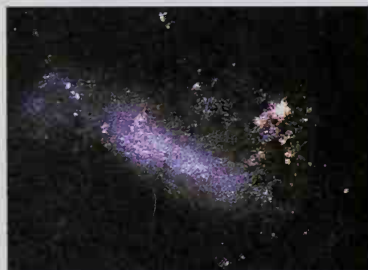

IRREGULAR GALAXY
Galaxies with no particular form are called irregular galaxies. Some of these may appear similar in shape to spiral galaxies. About three percent of all known galaxies are irregular in shape.



ELLIPTICAL GALAXY
Through a telescope, elliptical galaxies look spherical, or like flattened spheres. Small, so-called dwarf ellipticals are the most common type of galaxy in the known universe.



SPIRAL GALAXY
Most of the bright galaxies are spiral in shape. They are huge systems, normally about 100,000 light years in diameter. The Milky Way Galaxy is thought to be a typical spiral galaxy.



BARRED-SPIRAL GALAXY
Although often similar in appearance to a spiral galaxy, the arms of a barred-spiral galaxy start at the end of a straight bar of stars, which extends in two directions from its galactic nucleus.

NEIGHBORING GALAXIES

Some nearby galaxies are visible to the naked eye as fuzzy patches of light. One member of the Local Group, the Andromeda Galaxy (M31, NGC 224), is the most distant object visible to the naked eye – it is located about two million light years from the Earth – and appears to be very similar to our own Milky Way Galaxy.

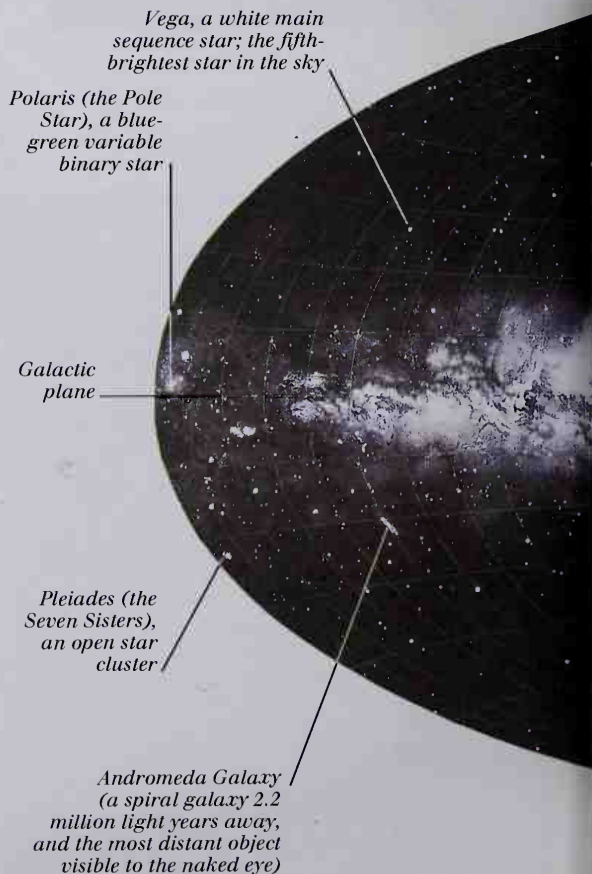
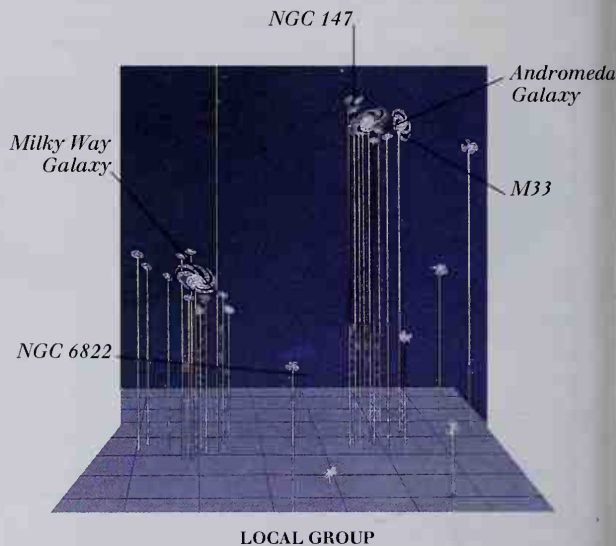

THE MILKY WAY GALAXY

The main part of the Milky Way Galaxy is about 100,000 light years across. Astronomers think that it is a spiral galaxy, but cannot be certain of this. The spiral nature of the galaxy can be inferred only from astronomical observations because the solar system is within it. The Solar System is part of the Orion Arm (one of four arms that make up

the galaxy) and rotates around the galactic center at a speed of 155 miles (250 km) per second. Traveling at this speed, the solar system takes about 220 million years to complete one lap of the galaxy. As is true of all spiral galaxies, star formation occurs mostly in the arms, while the galactic nucleus contains mainly older stars.

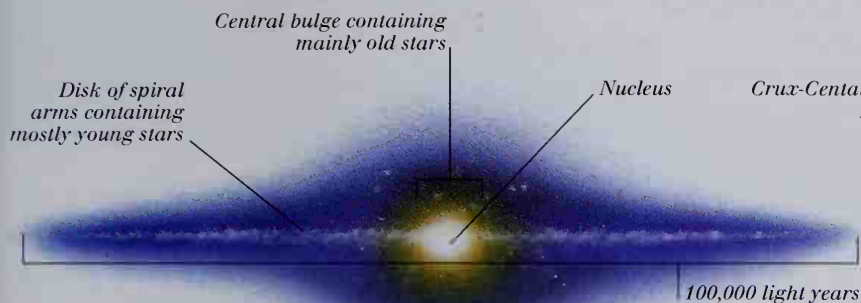

SIDE VIEW OF THE MILKY WAY GALAXY

PANORAMIC VIEW OF THE MILKY WAY GALAXY

Millions of the more distant stars within the galaxy can be seen in the night sky as a milky white band. This band runs across the sky in the direction of the galactic plane. From our position on the Earth, we are unable to see the central bulge of the galaxy.

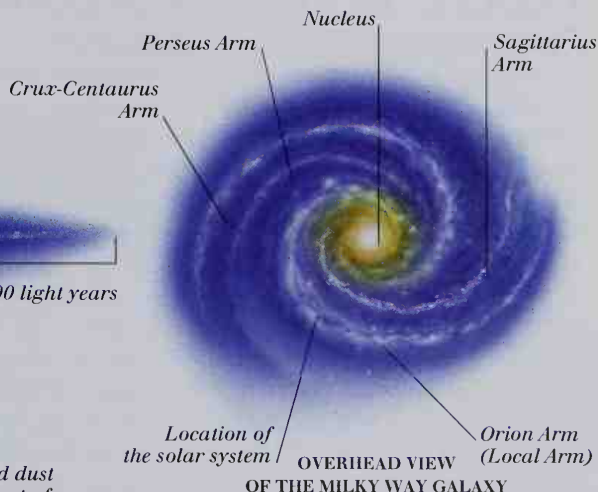
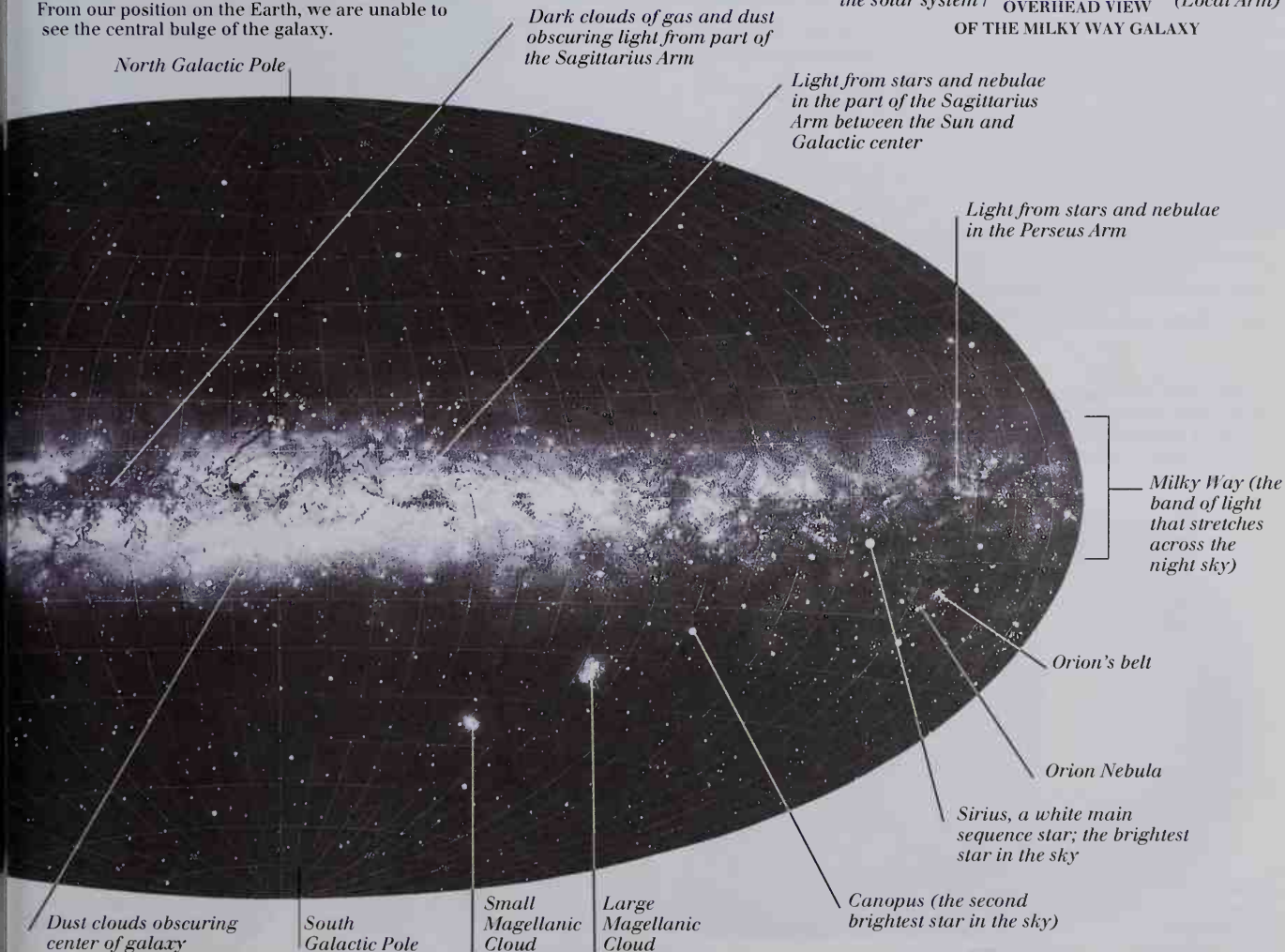

Neutron stars and black holes

THE FINAL STAGES of any star's existence are determined by the extent of its **gravitational** collapse, and the core that remains after a **supernova** explosion (see pp. 326-327) may become a neutron star or, if it has enough **mass**, a black hole. Stars consist largely of **protons**, **neutrons**, and **electrons**. As a star shrinks, crushing the **matter** of which it is made into a smaller and smaller **volume** and thereby increasing its **density**, protons and electrons are pushed together with such force that they become neutrons. At this stage the stellar remnant is composed almost exclusively of neutrons and so is called a neutron star. Rapidly rotating neutron stars are called pulsars (*pulsating stars*). The gravitational pull on anything near a neutron star is enormous, but around a black hole it is so great that even **electromagnetic radiation** cannot escape it. When a neutron star or black hole interacts with a nearby star, it can develop an **accretion disk**, which is visible as a strong **X-ray** source. The gravitational effect around a black hole is so great that it distorts **space-time**, perhaps enough to produce wormholes, hypothetical pathways to other places and times, or even other universes. It is thought that black holes exist at the centers of most galaxies, including our own.

PULSAR (ROTATING NEUTRON STAR)

Neutron stars can be detected in two ways. First, gases accelerated by its intense gravitational field emit X rays as they hit the solid surface. These X rays are then detected by X-ray telescopes. Second, because neutron stars tend to spin, they emit pulses of radio waves, which are produced as the strong **magnetic field** of the star interacts with the star's own charged particles.

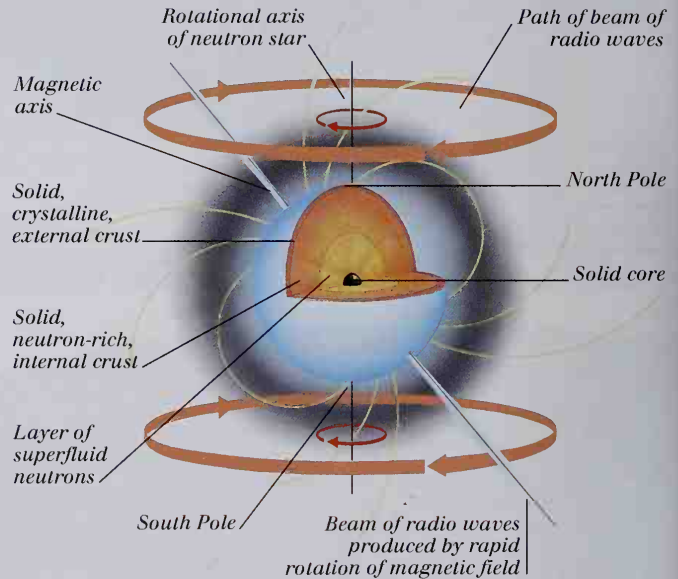

FORMATION OF A BLACK HOLE

During a supernova explosion, much of the star's mass is thrown off into space. The remaining core may become a neutron star or, if massive enough, a black hole. The stronger the gravitational pull at the surface of the stellar remnant, the higher is the speed required to escape from it.

When this escape velocity is equal to the speed of light, even electromagnetic radiation cannot escape. This is a black hole, the surface of which is called an event horizon. In theory, there is a region of infinite density, called a **singularity**, at the center of a black hole.

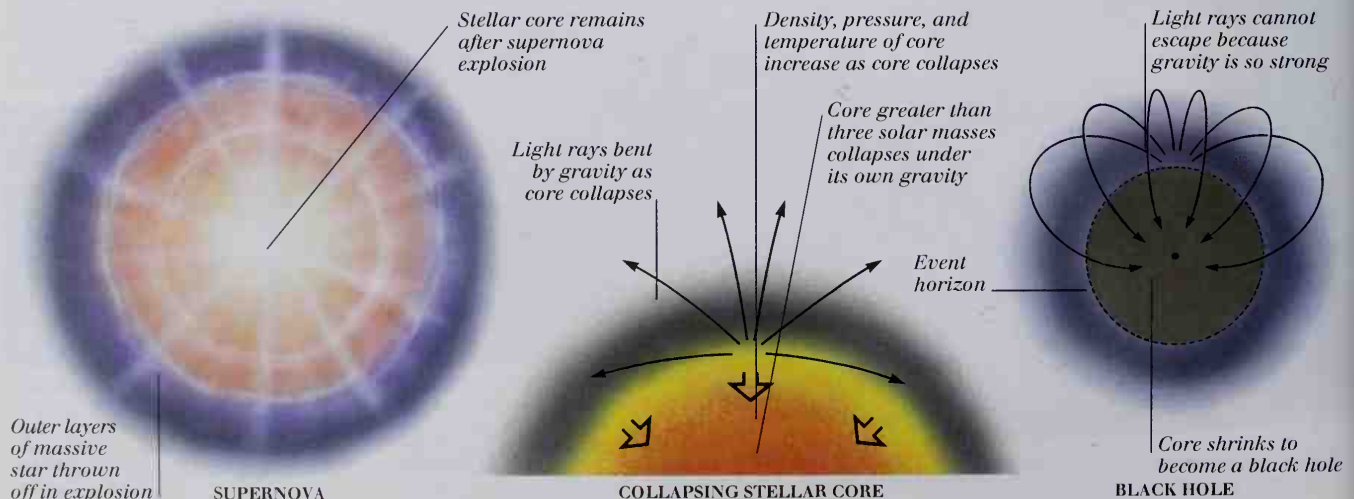

ACCRETION DISK

Black holes are impossible to observe directly, since no electromagnetic radiation can escape from them. However, matter drawn off a nearby star by tremendous gravitational attraction – to either a neutron star or a black hole – forms a rotating accretion disk. As it falls onto a neutron star, or into the black hole, the matter is heated to temperatures of millions of degrees Celsius. Matter emits powerful X rays when heated to these temperatures, and so astronomers searching for neutron stars or black holes seek evidence of these strong X-ray sources.

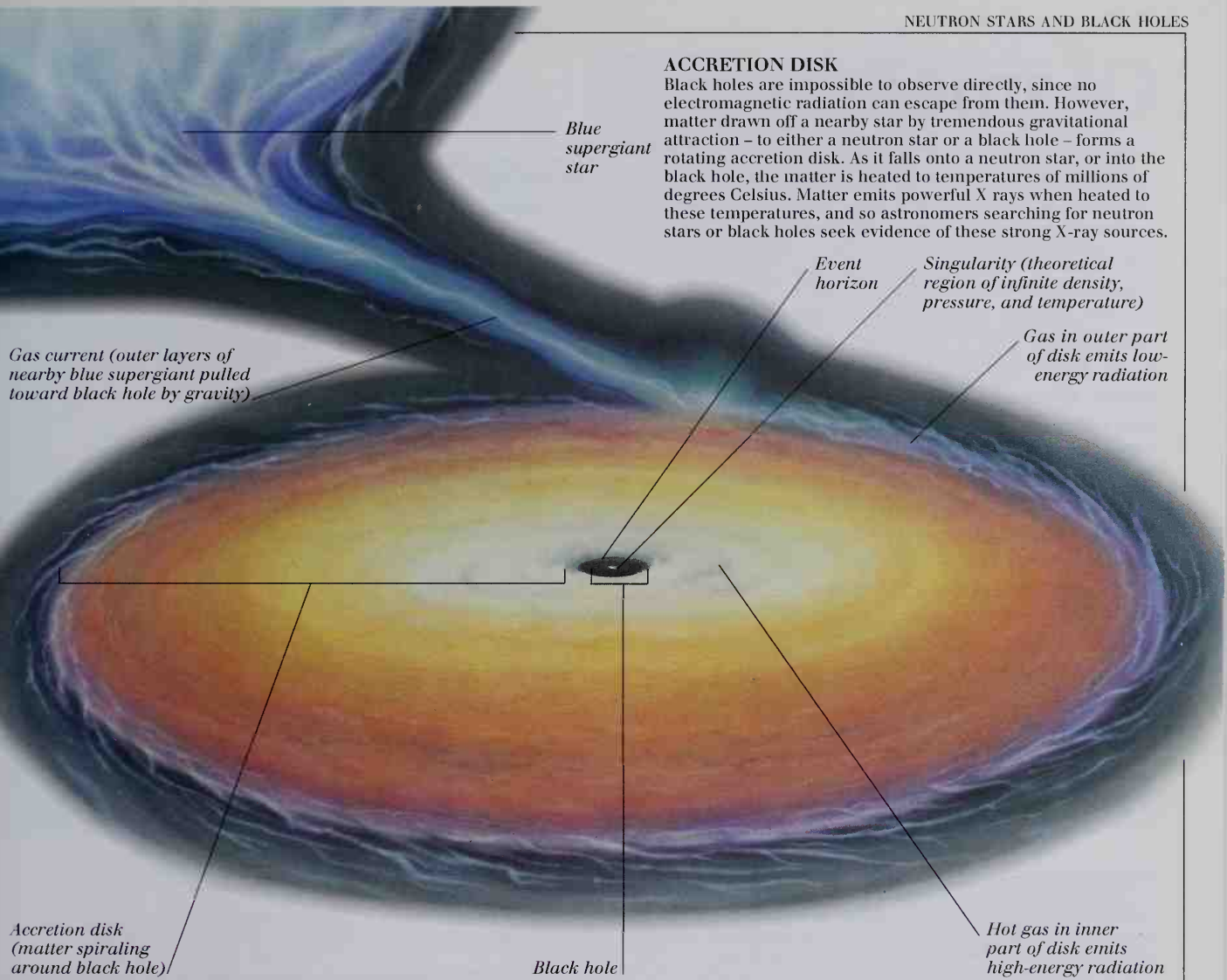

BLACK HOLES, WORMHOLES, AND THE GALACTIC CENTER

WORMHOLES IN SPACE-TIME

The General Theory of Relativity (see pp. 62-63) treats gravity as the distortion of space-time. It predicts that at a singularity, space-time is so distorted that it creates an open channel, or wormhole. This wormhole can exist between two black holes in the same universe, or perhaps between black holes in two different universes.

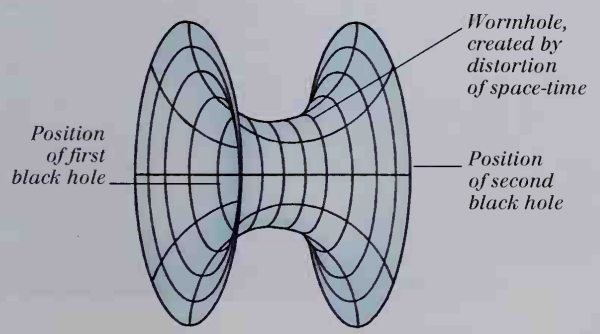

GALACTIC CENTER

In a photograph that shows up X-ray emissions, the center of the Milky Way Galaxy appears very bright. This suggests the possibility that there is a vast black hole situated there, creating an accretion disk out of interstellar gas and perhaps material from nearby stars. X-ray images of other galaxies – quasars, in particular – show similar results.

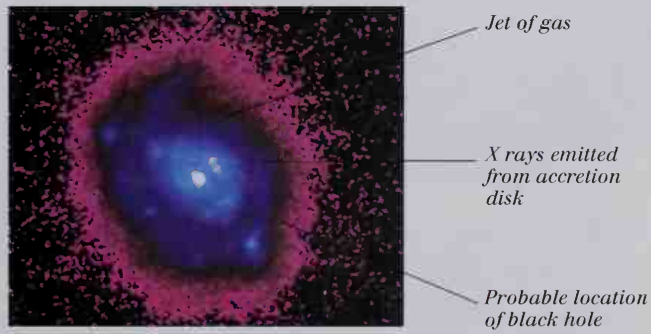

Cosmology

THE STUDY OF THE NATURE, origins, and evolution of the universe is called cosmology. People have long wondered about the creation of space and time, and modern astrophysics seems to be moving toward an answer. The universe is not infinitely old nor infinitely large – facts confirmed by a simple logical argument known as Olbers' Paradox. Instead, most astronomers believe that the universe came into existence between 10 and 20 billion years ago, in an explosion of space and time called the Big Bang. There is much evidence in support of this cosmological model. For example, galaxies are receding from the Earth in every direction, as if they all came from one point some time ago. The rate at which galaxies are moving away depends upon their distance from us – a simple relationship known as Hubble's Law. Quasars, the most distant observable objects in the universe, are receding most quickly. More evidence comes from the cosmic background radiation (CBR), a remnant of the Big Bang that has been observed by radio telescopes (see pp. 298-299) to come from every direction in space. Furthermore, there are ripples in the CBR, indicating a slight irregularity in the density of the early universe. This would have been necessary for the formation of galaxies. Ideas concerning the fate of the universe are also part of cosmology. If the Big Bang Theory is correct, then, depending on the total amount of mass present, the universe may begin to contract under its own gravity, concluding in a reverse of the Big Bang, named the Big Crunch.

OLBERS' PARADOX

If you were standing in an infinitely large crowd of people, you would see people in every direction. In the same way, if the universe were infinite, we would see star light coming from every direction in the sky. However, the sky is mainly dark, and so the universe cannot be infinite. This argument is known as Olbers' Paradox, after the German astronomer, Wilhelm Olbers.



The clumps contract due to gravity and become galaxies or clusters of galaxies

THE BIG BANG AND COSMIC EXPANSION

According to the Big Bang Theory, the universe began as an incredibly dense fireball. At the time of its creation, all of the mass and energy of the current universe was contained in a space far smaller than an atomic nucleus. The energy of the Big Bang gradually became matter, in accordance with the equation $E = mc^2$ (see pp. 62-63), where E is energy, m is the mass of the matter produced, and c is the constant speed of light. All the time, the universe was expanding, as it is still observed to do today.

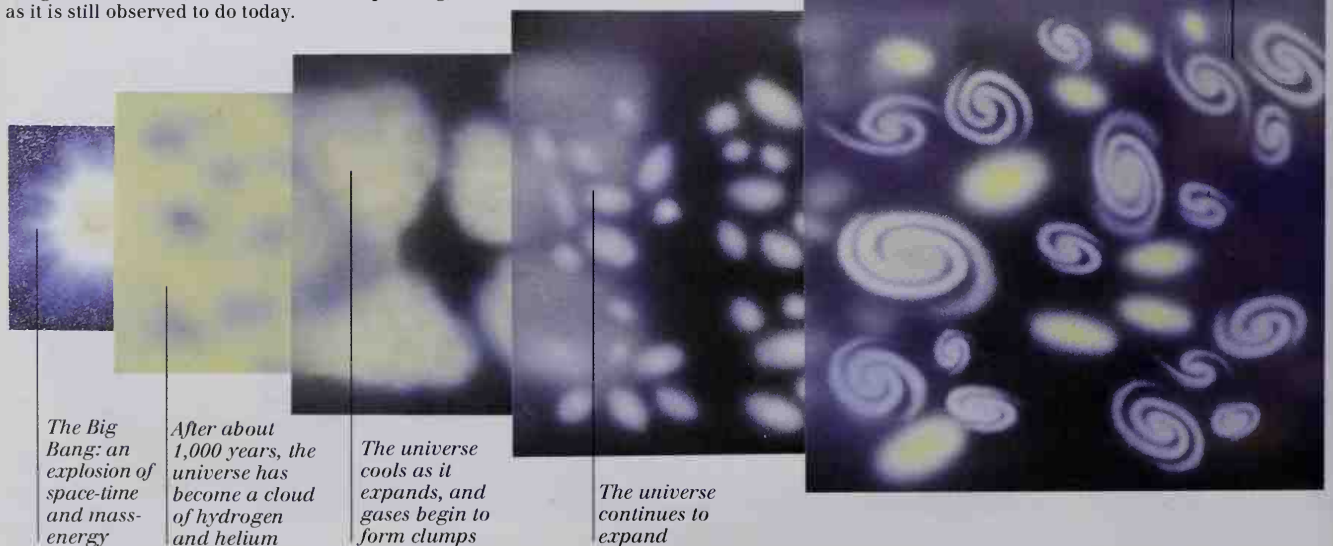

HUBBLE'S LAW

Distant galaxies appear to be moving away from us in whichever direction we look. The farther away a particular galaxy, the faster it recedes, a relationship known as Hubble's Law. This is consistent with an expanding universe, such as would have occurred after the Big Bang.

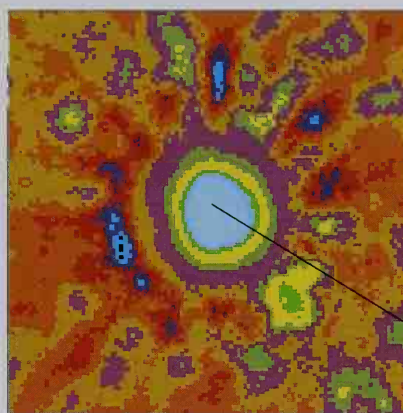
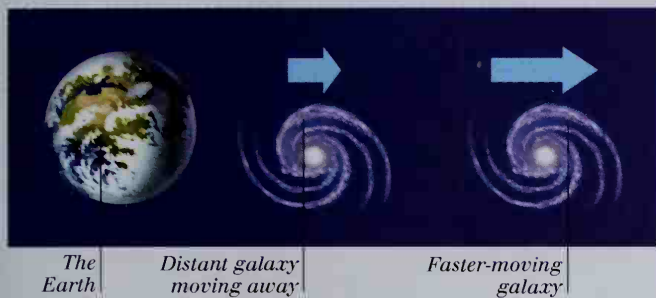

QUASARS

Quasars are the most distant observable objects in the universe. As they move away from us, the wavelengths of the radiation they emit is increased, or **redshifted**. Their huge value of redshift indicates that some quasars may be as far as 10 billion light years away from us.

False color image of quasar

CRITICAL DENSITY

The universe contains a huge amount of mass, which is more or less uniformly distributed, over a large scale. The gravitational effect of the mass slows the apparent expansion of the universe. If there is enough mass in the universe (in other words, if the density of the universe is above some critical value) the expansion may cease altogether and become a contraction, concluding with the Big Crunch (see below).

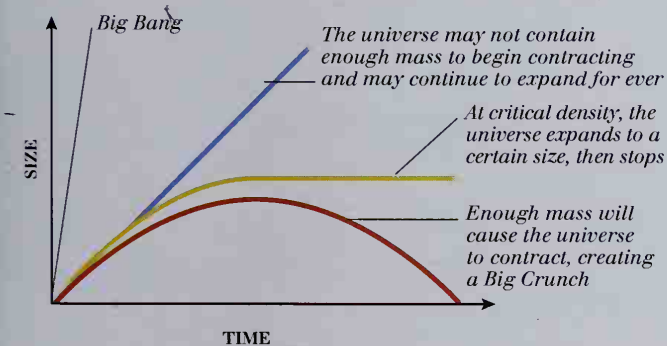

COSMIC BACKGROUND RADIATION

The strongest evidence so far in support of the Big Bang Theory is the cosmic background radiation (CBR). If CBR was produced at the time of the Big Bang, it provides cosmologists with information about conditions in the early universe. For galaxies to form, there would need to have been slight irregularities in the density of the young universe. These irregularities have been detected, as ripples in the CBR.

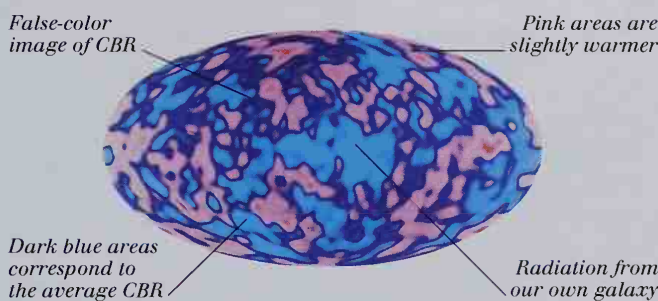

COSMIC CONTRACTION AND THE BIG CRUNCH

In the future, if the density of the universe is high enough (see above left), the cosmic expansion may cease, due to gravitational attraction, and reverse to become a contraction. Huge black holes will form and will attract one another, increasing the rate of contraction. Eventually all of space and time will become contained in a tiny volume – as it was at the time of the Big Bang. This is the Big Crunch scenario. It is possible that another universe could then be born out of the singularity formed by the Big Crunch.

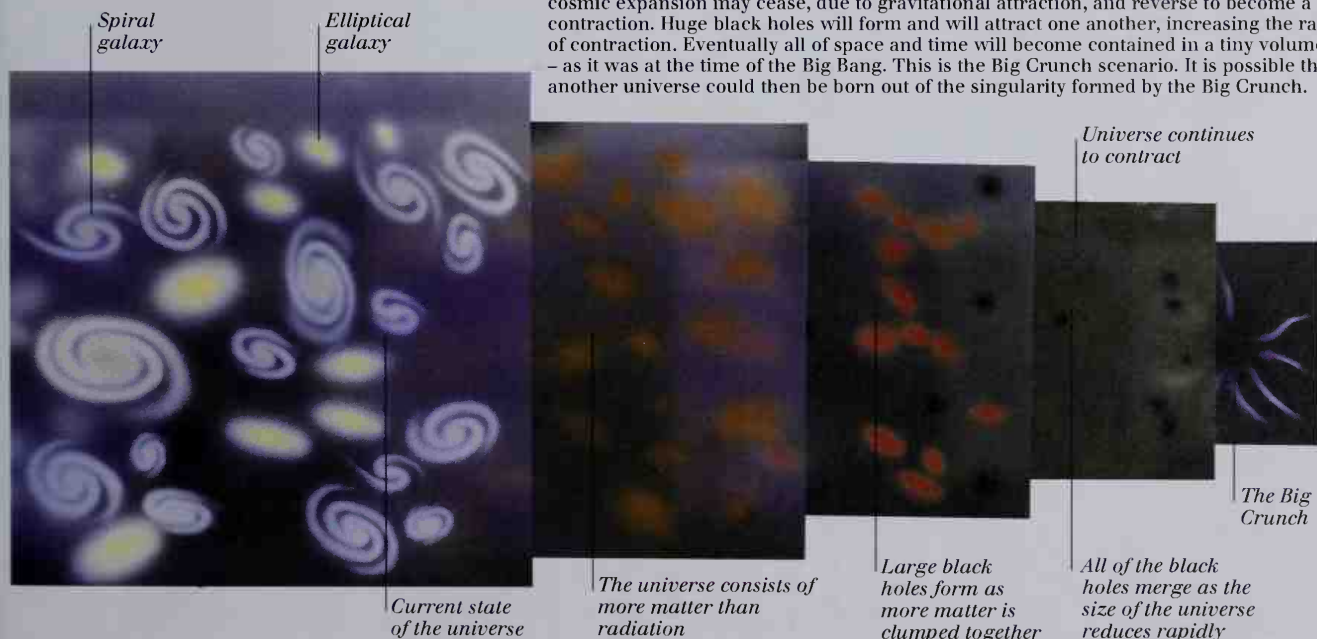

+B9018
DP8390CN
NS32490CN

S+B9024
DP8391AN

KOYO
KCO-010T
20.000 MHz
90-03

008B2A

MOSEL
MS6264L-10FC
8940A

EN500100
WNS02604
JAPAN

BOOT ROM

MADE IN
TAIWAN R. O. C.

COL X D2 R19 R16
D1 R9 301 0051
JAB R9 331 100
D3 R11 R17
X1 R19 U2
AT&T
T 7220 EG
19390SS 7
R6
R3
R4
R12
JP2 JP1
C35 C36 C34

IRQ		DMA		I/O	
2	3	4	5	6	7
13	13	A5	A6		

Ether Pair-8N

Printed circuit board from a computer

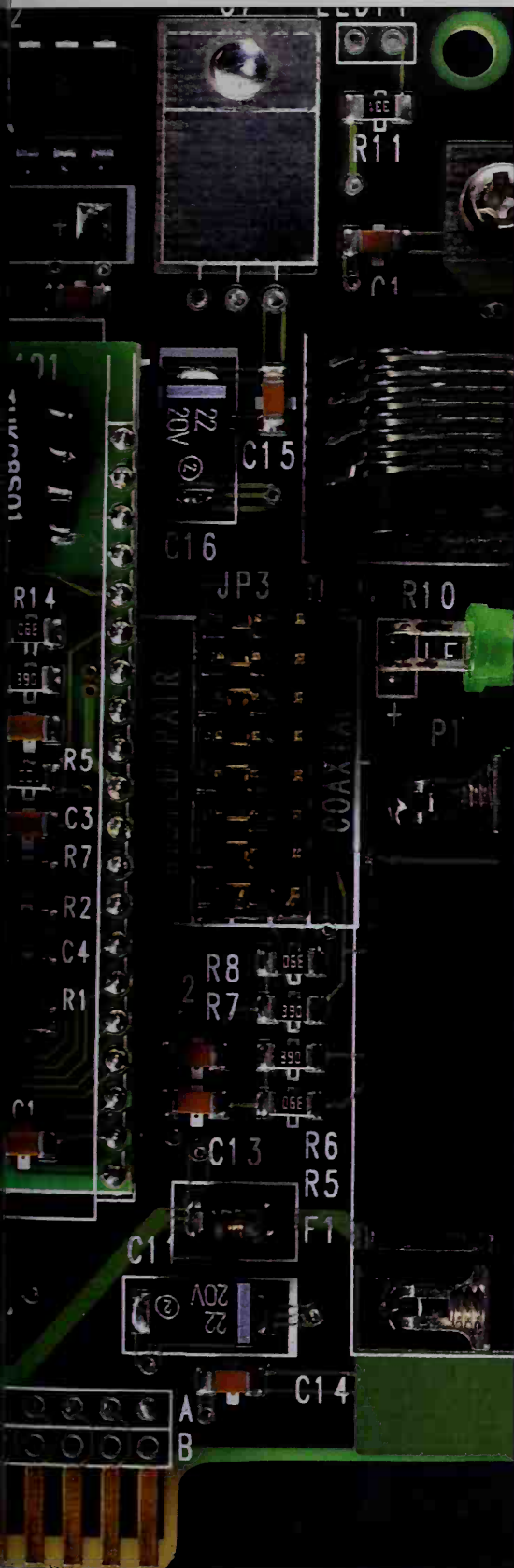

ELECTRONICS AND COMPUTER SCIENCE

DISCOVERING ELECTRONICS & COMPUTER SCIENCE ..	556
ELECTRONIC CIRCUITS	558
RESISTORS.....	540
CAPACITORS	542
INDUCTORS AND TRANSFORMERS	544
DIODES AND SEMICONDUCTORS	546
TRANSISTORS	548
INTEGRATED CIRCUITS	550
COMPUTERS	552
COMPUTER NETWORKS	554

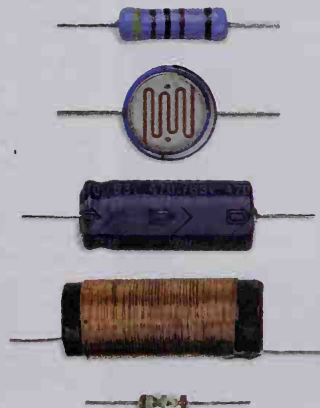



THE FIRST ELECTRONIC VALVE

John Ambrose Fleming was a British electrical engineer who adapted Edison's light bulbs by adding an extra electrode, enabling them to modify current for use in telegraph machines.



Discovering electronics and computer science

ELECTRONICS IS A BRANCH OF PHYSICS that deals with the behavior of electrons. In practice, it involves the design of useful electric circuits. One of the fruits of the growth of electronics is computer science. The impact of electronics on the modern developed world cannot easily be overestimated, with television, radio, modern telephones, and compact disc players becoming commonplace.

THE BEGINNING OF ELECTRONICS

All electronic circuits are powered by electricity. The first power stations were built during the 1880s, and batteries were already available at that time. Without the large-scale availability of electric currents from these sources, there would have been no "electronics revolution" during the 20th century. Around the time of the first power stations, many physicists were experimenting with cathode-ray tubes (CRTs). The discovery of the electron was made using a CRT. A CRT is a glass tube that contains a vacuum, in which streams of electrons are produced by a process called thermionic emission. Heat in a metal cathode (negative electrode) supplies energy to electrons, freeing them from the metal. Electrons emitted in this way are attracted to a positive electrode (anode) as a continuous stream – a cathode ray.

THE VACUUM TUBE

The CRT, or vacuum tube, developed into several important electronic devices. For example, the X-ray tube, the klystron (a device that produces microwave radiation), and the television tube are all based on it. The vacuum tube was first used in electronic circuits by English physicist **John Ambrose Fleming**, in 1904. He called it a "valve," because it allows electric current to flow in one direction only (electrons flow from the cathode to the anode). This simple property made it useful in detecting radio signals. Its

HOME-BUILT AMPLIFIER

This magnificent creation from the late 1920s is a home-built amplifier. At the time it was made, there was no large-scale industrial production of amplifiers. It has two valves to drive the loudspeaker and draws a great deal of power. In many respects, it resembles a modern amplifier.

value to the development of electronics was increased in 1906 by **Lee De Forest**, who added a metal grid between the anode and cathode. Voltages applied to the grid could control electric currents. The "triode," as De Forest's invention became known, was used in amplifier or oscillator circuits. Thanks to the development of the vacuum tube, electronics soon became a vital part of radio and sound recording.

SEMICONDUCTORS

Early radios depended on a "cat's whisker" for the detection of radio signals. This was a fine wire in contact with a crystal of germanium or other semiconductor material. Although this method of radio detection was superseded by the diode valve, scientific research into semiconductors was not carried out in vain. The semiconductor diode – made of a junction of different types of semiconductors – replaced the diode valve. Similarly, the transistor – a sandwich of three semiconductor layers – replaced De Forest's triode. This enabled electronic devices to be made much smaller and more cheaply. They also consumed less electric power. The transistor was invented in 1947, at Bell Laboratories in the United States. Transistors were used in radios and the newly invented magnetic tape recorders and televisions. Early electronic computers also benefited from the replacement of vacuum tubes by semiconductor diodes and transistors.

ELECTRONIC COMPUTERS

The idea of using a machine to carry out calculations has a long history that spans several centuries. The electronic computer, however, is a very recent invention. The basic idea behind the modern electronic computer was

conceived by the American physicist **John Atanasoff** and his colleague **Clifford Berry**. Around 1940, they built the "Atanasoff-Berry computer," the ABC. The desire for electronic computers was enhanced by the Second World War – the design of missiles and warplanes relied upon calculations being carried out quickly and accurately. Several computers were designed by military organizations during the 1940s. Perhaps the most famous is ENIAC (Electronic Numerical Integrator and Calculator), which contained 17,468 triode and diode valves. Computers that used transistors instead of valves were faster, smaller, and used much less electric power. The "architecture" (internal organization) of the modern computer was established by Hungarian-born American mathematician **John Von Neumann** in the late 1940s. His concept of a computer that has a memory, a flexible program (set of instructions), and a central processing unit (CPU) remains the model of computers today. Inside a computer, letters, numbers, and simple instructions are held as groups of "off" or "on" electrical pulses. These pulses represent the binary digits, or bits, "0" and "1". For this reason, the computer is an example of a digital device.

MINIATURIZATION

In 1958, American electronics engineer **Jack Kilby** devised a way of creating several electronic components on a single slice of semiconductor. Integration, as this is known, soon enabled complicated electronic circuits to be formed on a single "chip." This led to dramatic miniaturization of electronic devices, particularly computers. In the 1960s, integration became large-scale integration (LSI), and in the 1980s, very large-scale integration (VLSI), as more and more electronic components could be formed on to a single "integrated circuit." In the late 1970s, the microprocessor was born. This is a single integrated circuit that carries out calculations or a set of instructions. Microprocessors found their way into a host of devices, including facsimile (fax) machines, compact-disc (CD) players, camcorders, and even electric toasters. The microprocessor made possible pocket calculators (1970s) and the general-purpose, personal computer (late 1970s).

THE FIRST TRANSISTOR

Although it resembles components from earlier radios, this transistor is, in fact, a form of amplifier. Two wires are connected to the surface of a germanium crystal, while a third wire connects to the base. A change of current in one wire causes a larger change in current through the other.

COMPUTER NETWORKS

Electronics today is used in countless ways: in business, scientific research, entertainment, and just about every area of modern life. Much of the impact of electronics today is focused on computer networks – personal computers, as well as larger, "mainframe" computers and supercomputers, linked together by communications links such as fiber-optic cables. Information in digital form can be passed and shared across such networks. Individual networks can be connected to others. The Internet is just such a "network of networks." Its origins lie in the late 1960s, when the United States Defense Department set up ARPANET (Advanced Research Projects Agency Network). The strength of ARPANET was that it would be impervious to attack from hostile forces – if one part of the network was destroyed, information could be re-routed around other parts. Academics from universities across the United States were soon sending information across ARPANET, from their own networks. In 1985, several other networks joined ARPANET, and the Internet was born. In 1986, the "backbone" of the Internet was created by the American National Science Foundation. More and more networks, in other countries as well as in the USA, became connected to the Internet. By 1993, the Internet consisted of networks in 53 countries. Millions of people use the Internet every day, for the transmission of serious information and as a means of expressing opinions, as well as for entertainment or simply for keeping in touch with friends.

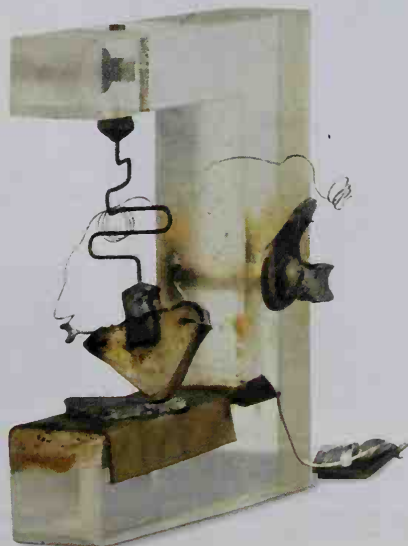

TIMELINE OF DISCOVERIES

	1642	– French mathematician Blaise Pascal invented a numerical calculator that could add and subtract
Gottfried Leibniz improved Pascal's device by creating a machine that could also multiply	1694	
	1705	– Gottfried Leibniz shows the importance of binary (base 2) mathematics, used in all digital electronic computers
Georg Ohm discovers the mathematical relationship between electric current and voltage, known as Ohm's law	1822	
	1827	– Charles Babbage designs general-purpose calculating machine, the analytical engine
Joseph Henry discovers self-inductance, the basis of electronic components called inductors	1850	
	1854	– George Boole develops Boolean algebra. Microprocessors use the mathematics of Boolean algebra in their calculations
William Crookes observes cathode rays in his "Crookes tube"	1879	
	1880	– Thomas Edison discovers the Edison effect
Electron is discovered by English physicist Joseph Thomson as he is studying cathode rays	1897	
	1904	– English inventor John Ambrose Fleming invents the thermionic valve
Lee De Forest develops the triode valve, the forerunner of the transistor	1906	
	1950s	– Claude Shannon develops electronic circuits called logic gates – the basis of the digital electronic computer
John Von Neumann figures out the internal structure, or "architecture," of the general-purpose electronic computer	1940s	
	1945	– ENIAC (Electronic Numerical Integrator and Calculator), the world's first truly general-purpose, programmable computer, is built
Printed circuit boards (PCBs) are perfected	1945	
	1947	– The transistor is invented at Bell Laboratories in the US
Jack Kilby develops the first integrated circuit	1958	
	1971	– The first microprocessor chip, the Intel 4004, is produced
Apple launches the first Macintosh computer. It uses the first commercially available GUI (graphical user interface)	1984	
	1995	– Microsoft launches Windows '95 software

Electronic circuits

ELECTRONIC CIRCUITS CARRY out countless different tasks, in devices such as radios, calculators, amplifiers, and computers (see pp. 352-353). All of these circuits work on simple principles and consist of various electronic components, such as resistors, capacitors, inductors, and semiconductor devices, including transistors and integrated circuits. These components are normally assembled on some kind of circuit board. Most commercial electronic circuits are built on printed circuit boards (PCBs), with copper tracks connecting the various components. Temporary, experimental circuits are often built on breadboards, into which the connecting legs of the components are pushed. A circuit diagram is a shorthand way of representing the connections between the components. When built, the input and output voltages and currents often need to be compared with desired values. A multimeter is used to measure these quantities. Many electronic circuits produce rapidly alternating voltages, which cannot be measured accurately on a multimeter. These can, however, be measured, and displayed, with the aid of an oscilloscope.

TYPES OF CURRENTS

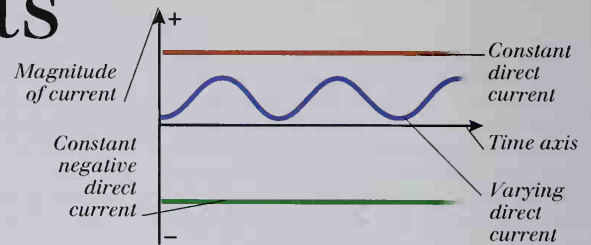

DIRECT CURRENT (DC)

The flow of electric charge in just one direction is called direct current, even if the magnitude of the current varies. Batteries and some power supplies produce direct current.

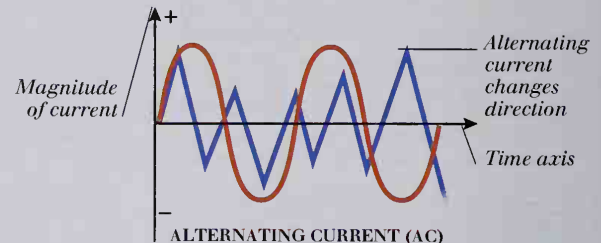

ALTERNATING CURRENT (AC)

Electric current that changes direction, or alternates, many times every second is called alternating current. Many devices, including oscillators, microphones, and some generators, produce alternating currents.

TYPES OF CIRCUIT BOARDS

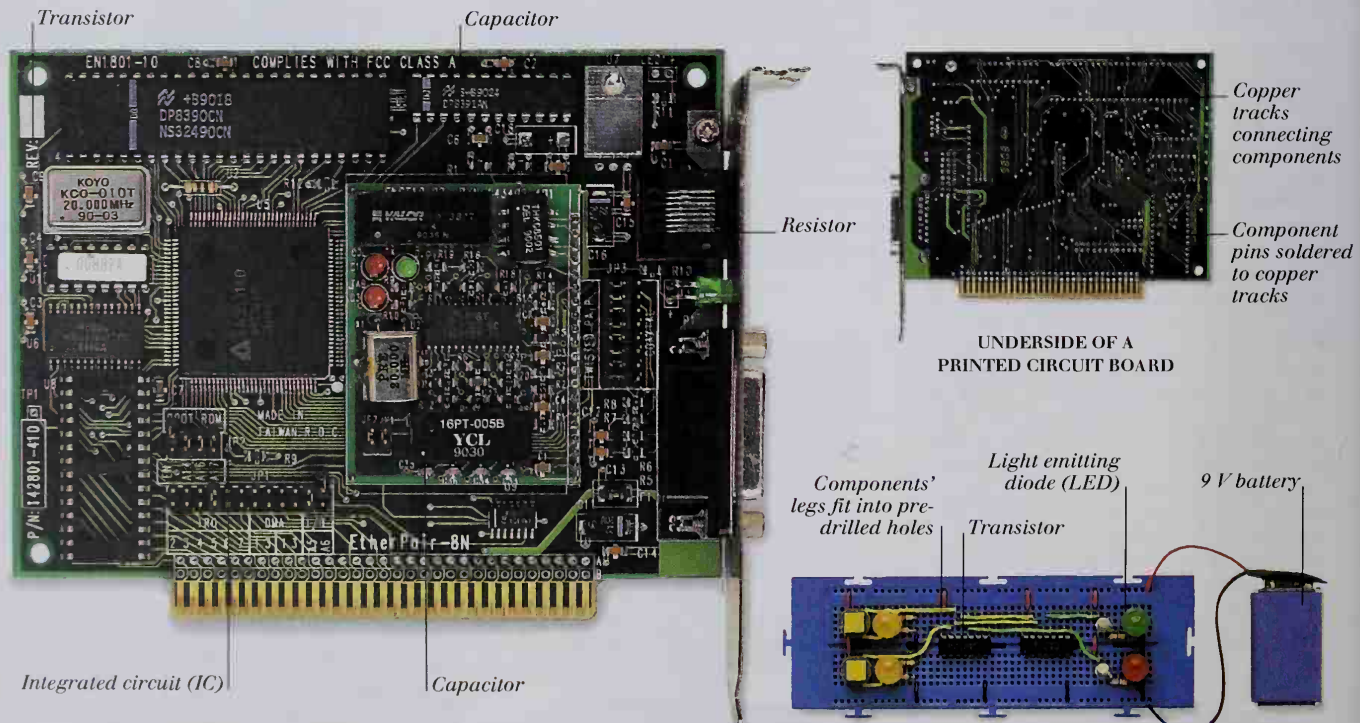

PRINTED CIRCUIT BOARDS

Several types of electronic components are visible on this printed circuit board, which is taken from a computer. Printed circuit boards are made of insulating materials such as ceramics, plastics, or glass fiber, coated with copper foil. The foil is etched away by a photographic process, to leave behind tracks that are used to connect the components together.

BREADBOARD

Many electronics engineers use a predrilled block called a breadboard to construct temporary prototypes of their circuits. The components' connecting legs are simply pushed into holes in the board. Metal strips inside the board connect the components together to form a circuit.

EXAMPLES OF CIRCUITS

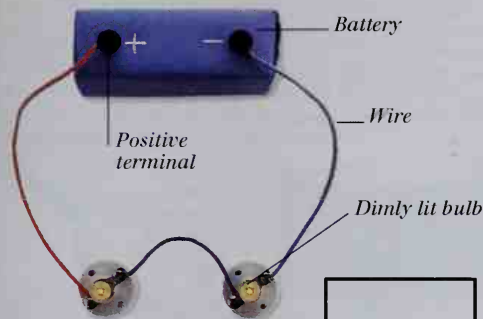

SERIES CIRCUIT

Components may be connected one after the other (in series) in a circuit. The current is the same at all points of a series circuit, but the voltage decreases gradually and the bulbs light only dimly.

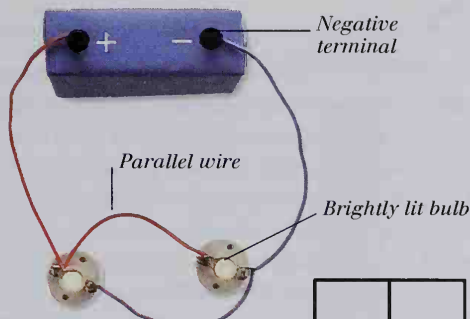
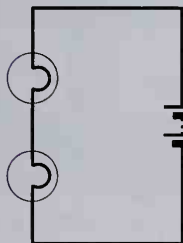

PARALLEL CIRCUIT

When components are connected in parallel, the current splits, depending on the resistances of each branch of the circuit. The voltage is the same throughout the circuit and so the bulbs are brightly lit.

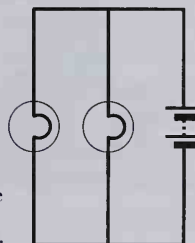

CIRCUIT SYMBOLS



TEST EQUIPMENT

ANALOGUE MULTIMETER

An electronics engineer will normally calculate the voltages and currents at certain points in a circuit while designing that circuit. A multimeter is then used to test these quantities once the circuit is built. Most meters can measure AC and DC, but they can also check resistances and capacitances.



Dial selects different voltage or current ranges

Meter can be used as a battery tester

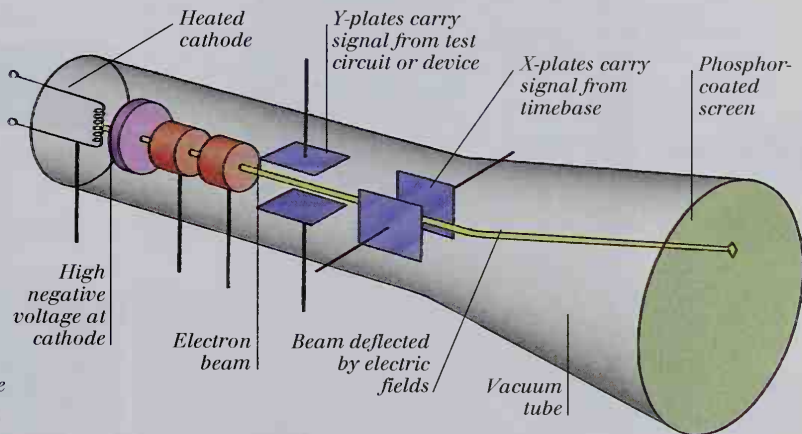

HOW AN OSCILLOSCOPE WORKS

Inside an oscilloscope is an electron beam that produces a spot on the screen of a cathode ray tube. Electric fields produced by two pairs of metal plates make the spot move around the screen. The field at the X-plates causes the spot to sweep across the screen, while a signal from a circuit under test is fed to the Y-plates, so that the spot is made to move up or down depending on the voltage of the signal.



USING AN OSCILLOSCOPE

When using an oscilloscope, the output of a test circuit is connected to the Y-input, which controls the vertical motion of the electron beam. The time taken for the beam to sweep horizontally across the oscilloscope screen is called the timebase. This beam can combine with the vertical motion to produce a wave pattern on the screen.

Resistors

RESISTORS ARE ELECTRONIC COMPONENTS that have known resistances. Most fixed-value resistors are filled with carbon granules, and are marked with color-coded bands that denote their resistance. This is measured in ohms (Ω) or kilohms ($k\Omega$, thousands of ohms). They are used in most electronic circuits, normally for one of two purposes – limiting current or controlling voltage. When incorporated into a circuit, resistors are often combined in series or in parallel. In addition to fixed resistors, there are several very useful types of resistors that have variable resistance. The most common of these is the potentiometer, which may be used as a volume control in mixers and other audio equipment. One important use of resistors is in voltage dividers. These consist of two or more resistors – in series – and are used to supply a desired voltage to different parts of a circuit. A voltage divider that incorporates a light-dependent resistor can be used in a light-sensitive circuit.

INSIDE A FIXED RESISTOR

Most fixed-value resistors consist of a case containing carbon granules. Another common type of resistor is formed from a ceramic tube coated with thin, metal film. End caps allow for connection to a circuit via connecting wires.

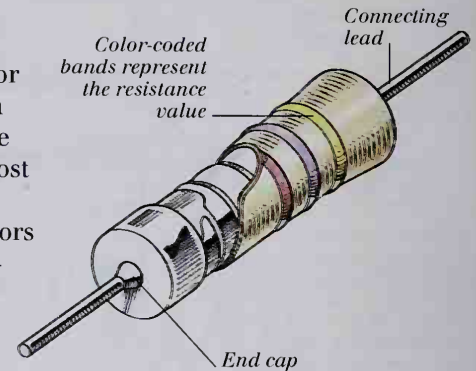

MEASURING RESISTANCE



DIGITAL MULTIMETER

Resistance can be measured using a digital multimeter. A battery inside the meter produces a voltage across the component, and measures the current flowing through it. The resistance is displayed directly.

RESISTOR NETWORKS

Combined resistance of 57 k Ω

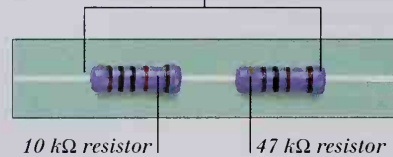

RESISTORS IN SERIES

The combined resistance of two (or more) resistors connected in series is simply the sum of the individual resistances. An electronics engineer who needs a 20 k Ω resistance in part of a circuit can simply connect two 10 k Ω resistors in series.

Combined resistance of 8.25 k Ω

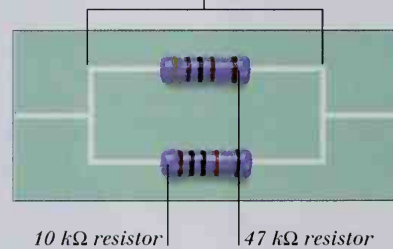

RESISTORS IN PARALLEL

The combined resistance of two resistors connected in parallel is less than the resistance of either of the resistances involved. (Total resistance is the product of the two resistances divided by their sum.) The total resistance in this circuit is 8.25 kilohms.

VOLTAGE DIVIDER

A component can be made to receive a fraction of the supplied voltage by using a pair of resistors connected together as a voltage divider. The voltage difference, or drop, between the ends of each resistor depends upon the values of the resistances involved.

3.6 V dropped by 100 Ω resistor

5.4 V dropped by 150 Ω resistor

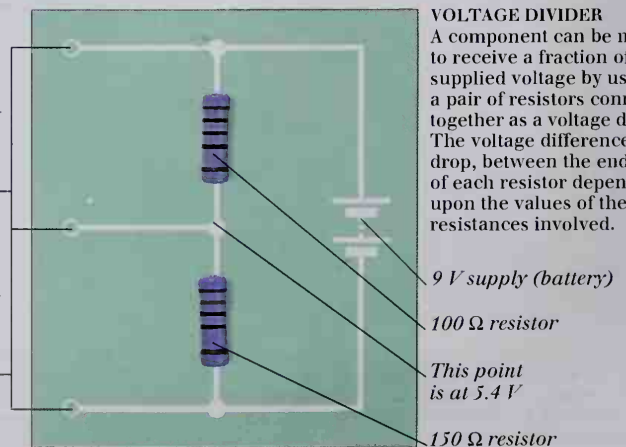

EXAMPLES OF RESISTORS

Potentiometers, which are a type of variable resistor, allow current or voltage to be controlled as desired, and have a wide range of applications. Potentiometers normally have a carbon track along which a slider makes contact. Thermistors contain a semiconducting material whose resistance decreases as it gets hotter. They are often used to compensate for the increase in resistance of other components that can occur at higher temperatures.

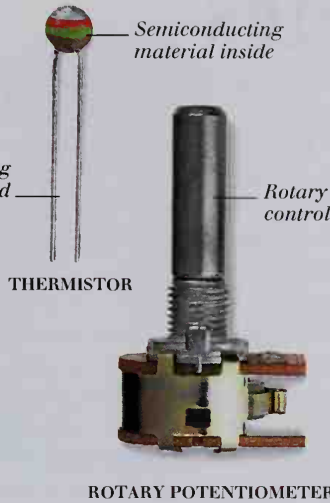
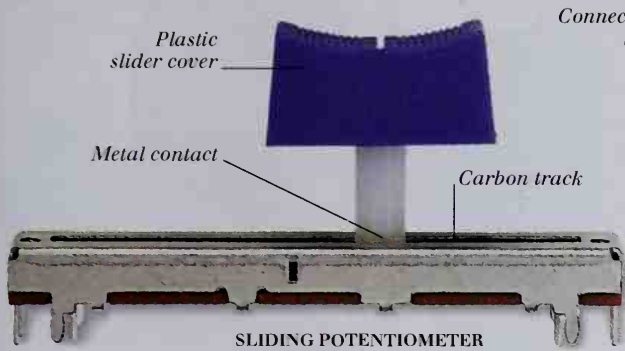

CIRCUIT SYMBOLS

- RESISTOR
- THERMISTOR
- VARIABLE RESISTOR
- POTENTIAL DIVIDER
- LIGHT-DEPENDENT RESISTOR

APPLICATIONS OF VARIABLE RESISTORS

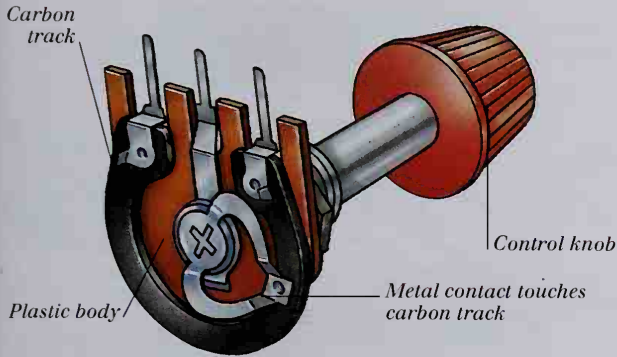

VOLUME CONTROL

Potentiometers are used as volume controls in circuits that produce an audible output. The varying resistance of a potentiometer, determined by the position of a metal contact on its carbon track, controls the amount of current flowing through the part of the circuit that drives the loudspeaker.



MIXING DESK

Mixing desks rely on several potentiometers, each one affecting the output of an amplifier circuit. In this way, the relative volumes of several instruments or voices can be controlled at the same time.

LIGHT-DEPENDENT RESISTOR CIRCUIT

As light falls on a light-dependent resistor (LDR), it decreases its resistance. This can be put to use in a circuit that switches on a light emitting diode (LED) when light falls upon the LDR (see below). The circuit includes two voltage dividers. The LED joins the midpoints (A and B below) of the two voltage dividers. It lights only if point A is at a lower voltage than point B. The voltage at point B is held at 3 volts. The potentiometer is adjusted so that, in the dark, point A is also at 3 volts. As points A and B are at the same voltage, the LED does not light. When light falls on the LDR its resistance drops, so that the potentiometer drops more voltage and the voltage at point A rises. The LED lights.

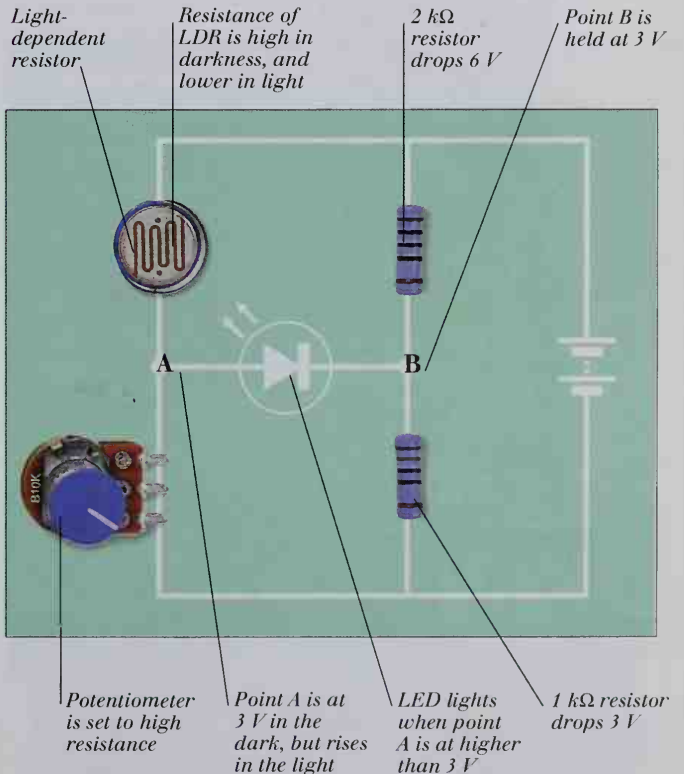

Capacitors

CAPACITORS STORE ELECTRIC charge when a voltage is applied across them. They can be found in almost every electronic circuit. Most capacitors have metal plates inside, separated by an insulating material called a dielectric. The charge stored on the plates increases as the voltage increases – the amount of charge a capacitor can store with one volt across it is called its capacitance and is measured in farads (F). Most capacitors are rated in millionths of a farad (microfarads, μF), or trillionths of a farad (picofarads, pF). A rapidly alternating current (AC) passes through a capacitor easily, while direct current (DC) cannot pass at all. For this reason, capacitors are often used to prevent the passage of direct current through a circuit, such as an amplifier (see pp. 548-549). In circuits that require the passage of AC, the current passing through the capacitor reaches a maximum when the voltage is at a minimum.

INSIDE A CAPACITOR

The metallized film capacitor is typical of most capacitors. Inside, plastic plates are coated with a thin layer of metal. The capacitance of such a component is increased by sandwiching several layers of plates very closely together.

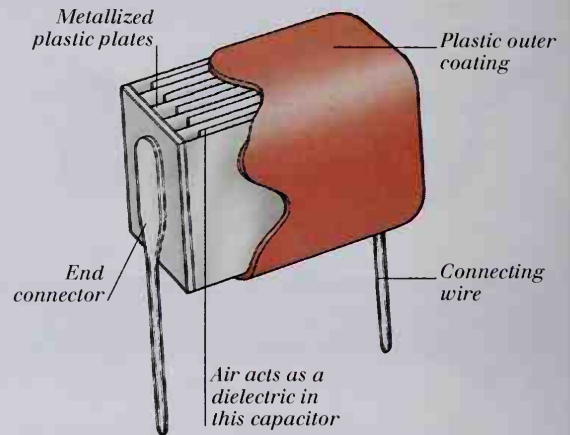

CHARGING AND DISCHARGING A CAPACITOR

RESISTOR-CAPACITOR CIRCUIT

A capacitor charges up when a voltage is applied across its plates. It discharges if the voltage is removed and its ends are connected to a circuit. The rate at which a capacitor charges and discharges depends upon the resistance (R) of the circuit or circuits involved and the capacitance (C) of the capacitor. This arrangement is therefore called a resistor-capacitor circuit or, more commonly, an R-C circuit.

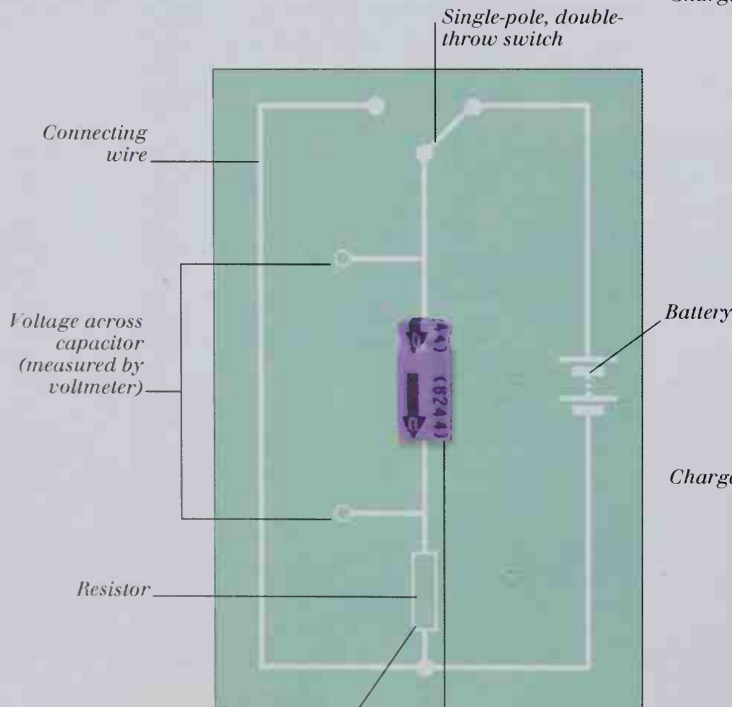

The higher the resistance, the more slowly the capacitor charges or discharges

The higher the capacitance, the more slowly the capacitor charges or discharges

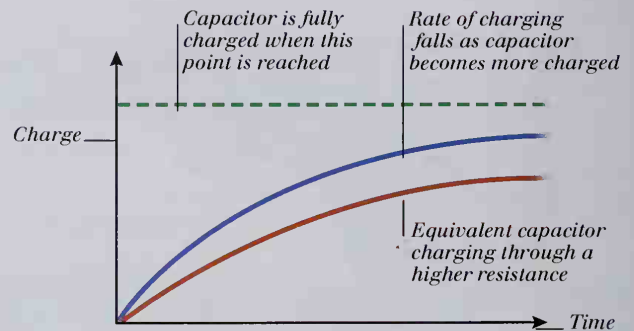

CHARGING

A voltage connected across a capacitor pulls electrons away from one plate and forces electrons onto the other. This creates an electric field between the plates, which becomes strong enough to prevent any further charging. (The current flowing through the capacitor falls to zero at this point.)

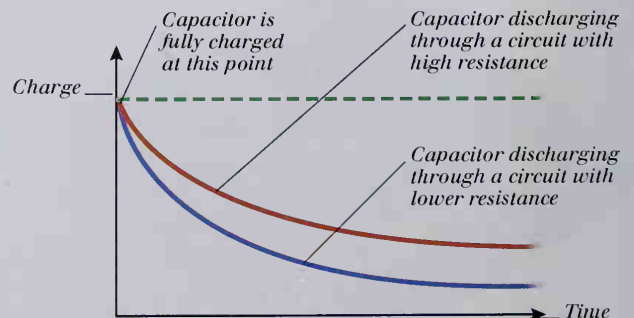

DISCHARGING

When the voltage is removed and the capacitor's plates are connected together with a resistor, the capacitor forces the stored charge out once more, so a current flows in the opposite direction. The current reduces as the capacitor discharges and falls to zero when it is fully discharged.

EXAMPLES OF CAPACITORS

Different types of capacitors are used in different parts of circuits, depending on their desired function. Variable capacitors are used in the tuning circuit of most radios (see pp. 544-545). Variable capacitance can be achieved by allowing plates to move past each other. When a high capacitance is needed, an electrolytic capacitor is used. The dielectric in this type of capacitor is a very thin layer of aluminum oxide that forms on the aluminum plates.

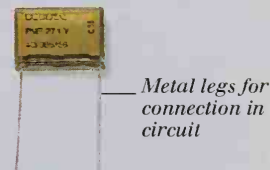
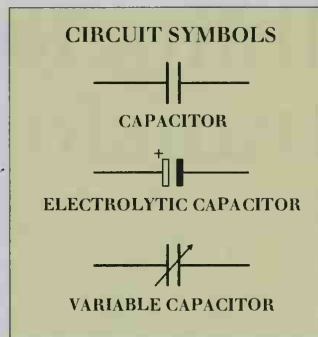
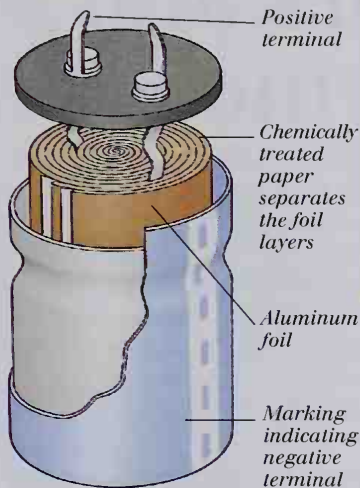
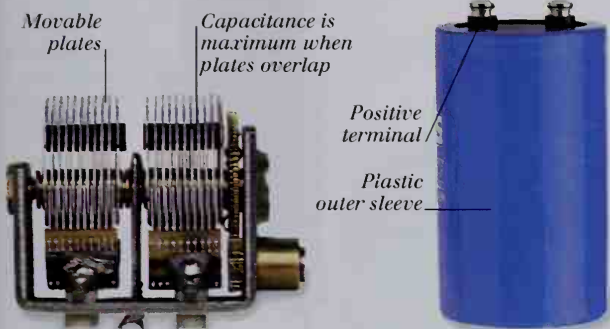

VARIABLE CAPACITOR

ELECTROLYTIC CAPACITOR

METALLIZED FILM CAPACITOR

CAPACITOR NETWORKS

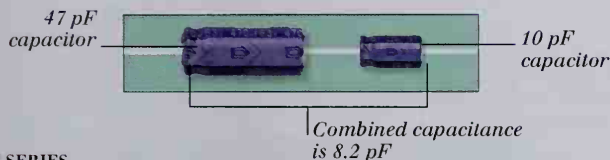

IN SERIES

The total capacitance of two capacitors in series is less than either of the capacitances involved. The overall capacitance (C) can be figured out by the formula $1/C = 1/C_1 + 1/C_2$ (where C_1 and C_2 are the values of the capacitances involved).

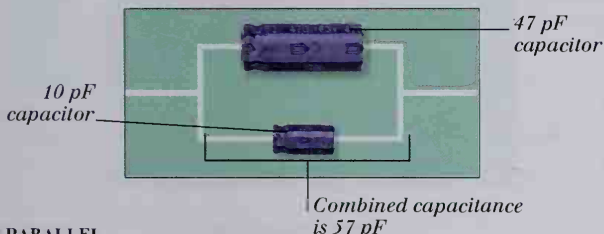

IN PARALLEL

The overall capacitance of two capacitors in parallel is equal to the sum of the capacitances involved ($C = C_1 + C_2$). Charge can be stored by one or other of the capacitors.

VOLTAGE CURRENTS IN CAPACITORS

Alternating current (AC) passes easily through a capacitor. As the voltage applied to the capacitor changes direction, the capacitor charges and discharges. The current is at a maximum when the voltage is zero (which occurs twice in each cycle).

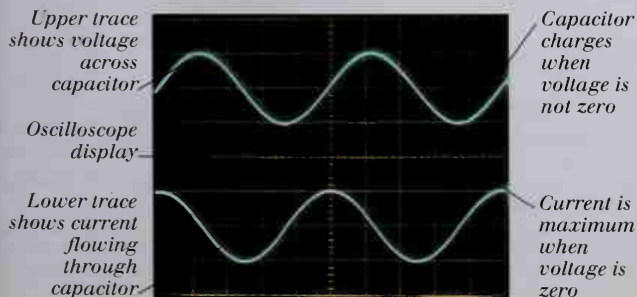

STORING CHARGE

The dome of a Van de Graaff generator (see pp. 40-41) is effectively a huge capacitor. It can store as many as 10 million volts. When the Van de Graaff generator (see below) is activated, huge sparks leap through the air, as the voltage created by the separation of charge causes a breakdown of the surrounding air into ions, and a current flows.



Inductors and transformers

ANY COIL OF WIRE can be called an inductor. An **electric current** flowing in an inductor creates a **magnetic field**. If the current changes, the field changes. This change in the magnetic field always acts to impede (resist) the change in current, so inductors resist **alternating current (AC)**, while allowing **direct current (DC)** to pass unimpeded. The more rapidly the current changes, the greater the impedance, so inductors allow lower-frequency AC through more easily than higher-frequency AC. Inductors have many applications in electronic circuits. For example, inductors called solenoids are used to control switches called relays. Transformers, which are used to increase or decrease **voltage**, consist of two separate inductors wound around the same iron core. When AC passes through one inductor, the magnetic field it produces induces a current in the other.

INSIDE AN INDUCTOR

Most inductors are wound onto a core of iron, or more often onto a **compound** called a ferrite. The core intensifies and focuses the magnetic field produced by the inductor. Ferrite compounds have magnetic properties, but unlike iron, they do not conduct electricity.

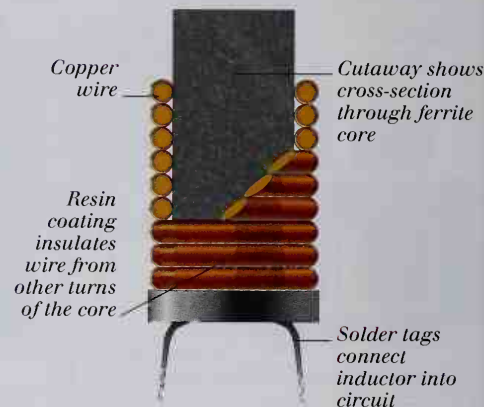

SELF INDUCTANCE

A fluctuating magnetic field is created when an alternating current is supplied to a coil of wire. Each change in the field produces an **electromotive force (emf)** in the coil, a process known as self induction. The current produced in the coil by this emf always opposes the change in supply current. A coil that produces a high emf in this situation is said to have a high self inductance.

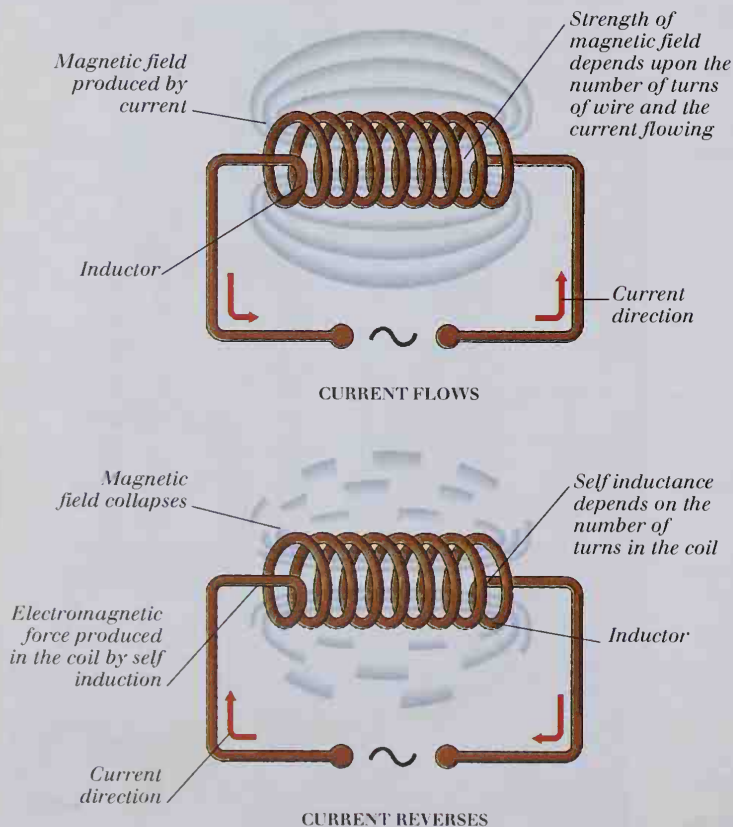

INDUCTORS IN AC CIRCUITS

Inductors allow direct current (DC) to pass unimpeded but resist the flow of alternating current (AC). As can be seen using an oscilloscope, the trace from the AC is not in step with the trace of the voltage applied to the inductor.

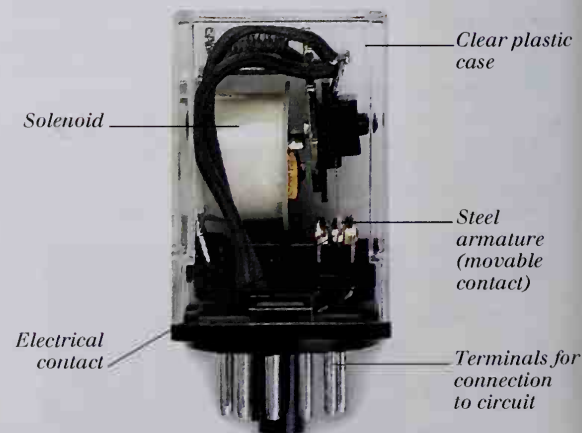
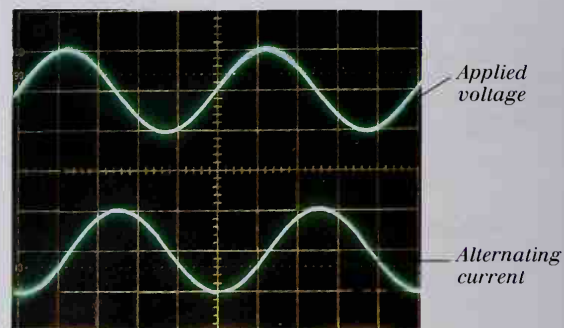

RELAY

A relay is a type of electromechanical switch. A magnetic field is created around a solenoid when a current flows through it. This attracts a steel armature, which in turn forces a pair of electrical contacts together and completes a circuit.

EXAMPLES OF INDUCTORS AND TRANSFORMERS

There are many types of inductors, which are used for countless applications in electronic circuits. An RF choke is used in radio circuits to filter out unwanted frequencies. Transformers are used to change high voltages into the lower voltages required for domestic appliances. An audio transformer generally increases the voltage of a signal in order to drive a loudspeaker.



RF CHOKE



GENERAL-PURPOSE INDUCTOR



AUDIO INDUCTOR



INDUCTOR FOR BLOCKING CURRENT INTERFERENCE

Output wires to low-voltage appliance



TOROIDAL TRANSFORMER

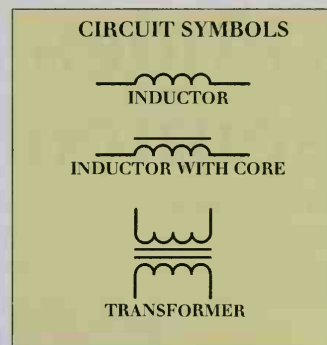

AUDIO TRANSFORMER

HOW TRANSFORMERS WORK

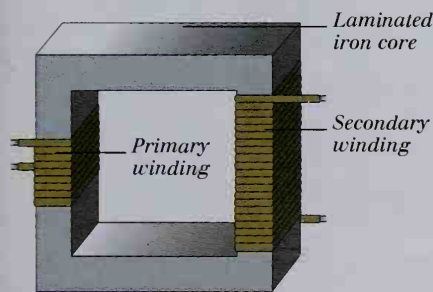

STEP-UP TRANSFORMER

When the primary winding has fewer turns of wire than the secondary, the output voltage at the secondary is higher than the voltage supplied to the primary. Current is reduced as a consequence of the increase in voltage.

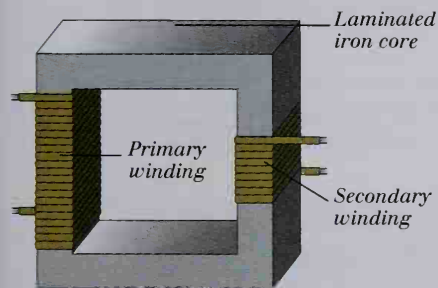

STEP-DOWN TRANSFORMER

When the primary winding has more turns of wire than the secondary, the output voltage at the secondary is lower than the voltage supplied to the primary. Current is increased as a consequence of the decrease in voltage.

TUNED CIRCUIT

When a capacitor (pp. 342-345) and an inductor are connected, or coupled, in parallel they form a tuned circuit. The capacitor discharges through the inductor, creating a magnetic field. When the field collapses, it produces a current that charges the capacitor again. This process repeats at a rate – called the resonant frequency – that depends on the capacitance and inductance of the components in the circuit. The circuit produces a large output when supplied with an alternating current that matches its resonant frequency.

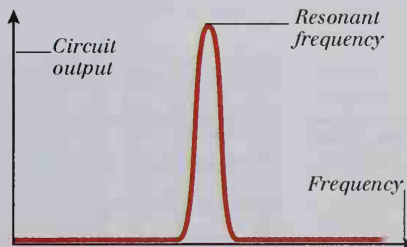
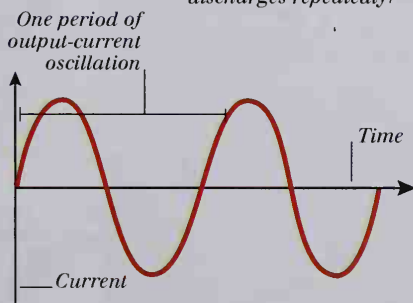
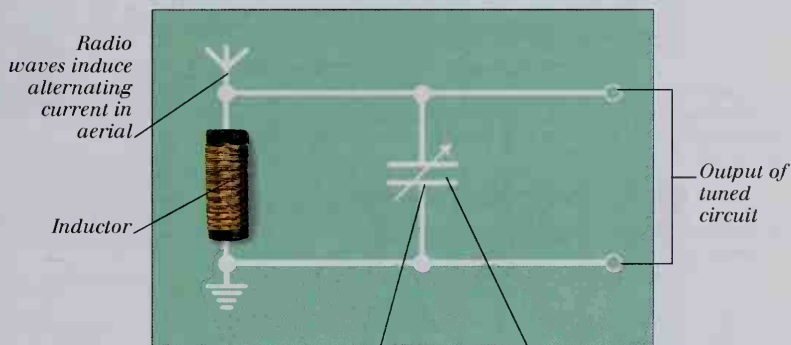

CIRCUIT OUTPUT

An oscilloscope connected to the output of a tuned circuit shows current alternating at the circuit's resonant frequency.

RESONANCE

A graph of the output of the circuit, plotted over a range of frequencies, centers on the resonant frequency.

Diodes and semiconductors

DIODES ARE ELECTRONIC components that restrict the flow of electric current to one direction only. They are made from materials called semiconductors, most notably the element silicon (see pp. 104-105). The addition of small amounts of other elements to a pure semiconductor (doping) produces two new types of materials, called p-type and n-type semiconductors. A diode consists of small regions of both types, combined to form a p-n junction. This p-n junction is utilized in transistors and integrated circuits (see pp. 348-349 and 350-351), as well as in light-emitting diodes (LEDs), where current flowing across the junction produces light. Diodes are commonly used to change alternating current (AC) into direct current (DC). This operation is called rectification, and diodes or diode circuits that achieve it are called rectifiers.

INSIDE A DIODE

All semiconductor diodes consist of a p-n junction (see below). The junction is often bonded by a lead or silver strip and encased in glass. Metal wires enable connection to an electronic circuit.

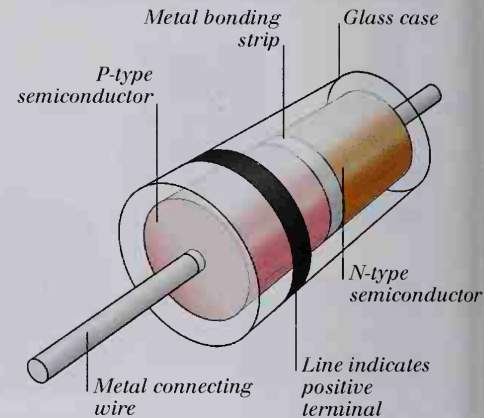

DOPING A SEMICONDUCTOR

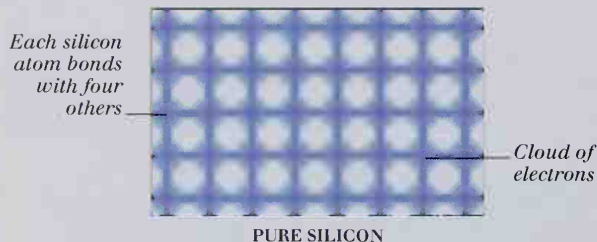

PURE SILICON

A crystal of pure silicon consists of millions of silicon atoms. Electrons are held only loosely to the atoms, and when they are given extra energy – for example by light or heat – they become free and can flow through the crystal as an electric current.

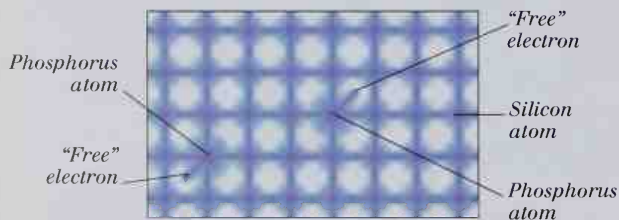

N-TYPE SILICON

In n-type silicon, some electrons are free of the atoms and can move through the crystal. To produce n-type silicon, the crystal is doped with other atoms, such as those of phosphorus.

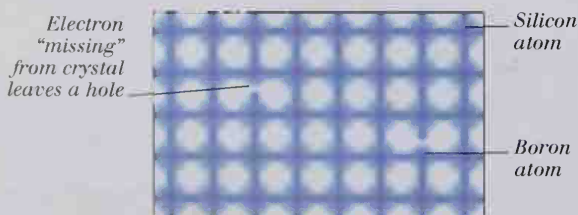

P-TYPE SILICON

In p-type silicon, some positions in the crystal are unoccupied, leaving a "hole." When an electron moves into this hole, the hole effectively moves to where the electron came from and a charge is carried. P-type silicon is often produced by doping the crystal with atoms of boron.

SEMICONDUCTOR DIODE

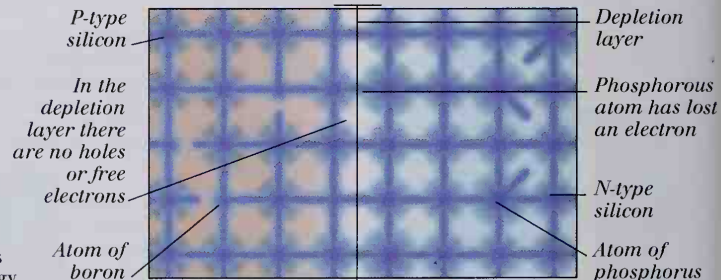

P-N JUNCTION

Inside a diode, p- and n-type silicon form a p-n junction (which is often made from a single, appropriately doped crystal). At the junction boundary is the depletion layer, in which electrons from the n-type silicon have filled holes in the p-type silicon. This layer acts as a potential barrier to any further movement of charge carriers.

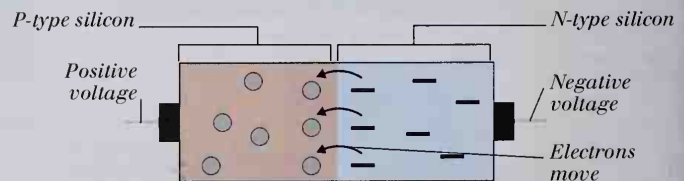

FORWARD BIAS

A diode conducts electricity when a voltage is applied in one direction only (forward bias). Electrons from its n-type region are attracted across the p-n junction and flow around the circuit. The barrier formed by the depletion layer is reduced, and charge flows easily through the crystal.

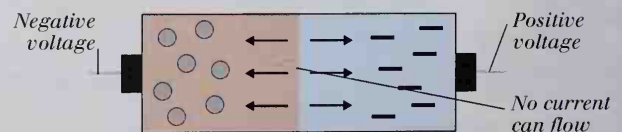

REVERSE BIAS

When the voltage is reversed, electrons are pulled away from the p-n boundary toward the positive voltage, and "holes" are pulled away from the depletion layer. This has the effect of raising the barrier, and virtually no current flows.

EXAMPLES OF DIODES

Diodes that control larger currents, such as those in power supplies, are called rectifiers. Diodes that control small voltages, such as those in telecommunications circuits, are called small-signal diodes. Light-emitting diodes (LEDs) are used as power-indicator lights and in moving-sign displays. Infrared LEDs produce a beam of invisible infrared radiation and are used in remote controllers. Often, LEDs in the form of strips are used in displays in calculators and alarm clocks.

Red or green LEDs are the most common

CIRCUIT DIAGRAMS



DIODE

LED

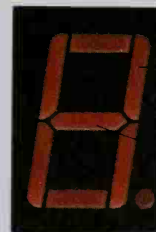

Each segment is an LED

Digits are formed by activating the correct combinations of LEDs

Anode (positive terminal)

LARGE DIODE



Anode lead (positive)

Cathode lead (negative)

SMALL-SIGNAL DIODES

P-n junction is encased in colored plastic

Package contains bridge rectifier circuit



SMALL RECTIFIER



LEDs

LED DISPLAY

VOLTAGE-CURRENT GRAPH

A diode's characteristics can be summarized on a voltage-current graph, shown here. Even when forward biased, very little current can flow through a diode until the voltage exceeds about 0.6 volts. This voltage is called the contact potential and is required to overcome the potential barrier created by the depletion layer (see left). Above 0.6 volts, the current rises steeply. To the left of the vertical axis, the voltages are negative, and the diode is reverse biased. Very little current flows until the voltage reaches about 150 volts. At this large voltage, the semiconductor crystal breaks down, and electrons are ripped from their atoms, making the whole diode conduct.

DIODE CHARACTERISTICS

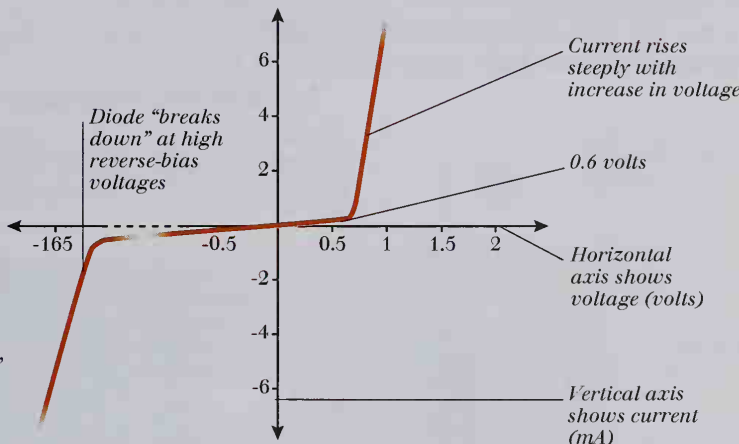

CONVERTING AC TO DC

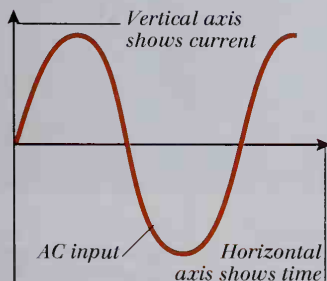

AC INPUT

Mains electricity is supplied as an alternating current (AC). Many domestic appliances require direct current (DC). A rectifier circuit, which makes use of a number of diodes, converts the AC to DC.

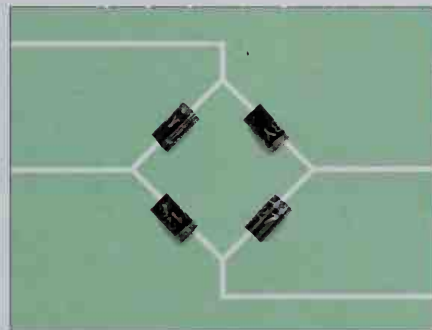

BRIDGE RECTIFIER

A four-way bridge of diodes is generally used as a rectifying circuit in AC adapters. Different sections of the bridge allow current to flow to the output circuit - in one direction only - during different stages of the supply cycle.

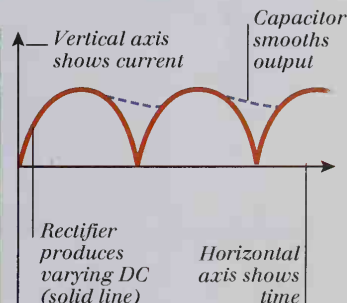

DC OUTPUT

A full-wave rectifier circuit has an output that rises and falls with the supply current. A capacitor, which charges when current is high and discharges as it falls, compensates for the varying DC output.

Transistors

THE WORD "TRANSISTOR" is derived from "transfer resistor"; transistors act as variable resistors, controlling currents and voltages in most electronic circuits. A typical transistor is made of sections of n-type and p-type semiconductors (see pp. 346-347). There are two main types of transistors: bipolar and field-effect (FET). In a bipolar transistor, a small current flowing through the central section (the base) controls a much larger current flowing between two outer sections (the emitter and the collector). There are two main types of field-effect transistors: junction (JFET) and metal-oxide-semiconductor (MOSFET). Both work in a similar way to a bipolar transistor, except that the main current flows between two sections called the source and the drain, and is controlled by a small voltage (not current) at the third section (the gate). There are many examples of transistors, each designed for specific working conditions. Some control high-frequency alternating current, while others are designed to work with high voltages or large currents. When used as a switch (see pp. 350-351), transistors have countless applications, including computer logic gates (see pp. 370-371).

INSIDE A TRANSISTOR

In a typical bipolar transistor (shown below) a layer of n-type semiconductor is sandwiched between two layers of p-type semiconductor, making a p-n-p structure. Alternatively, an n-p-n structure can also be used.

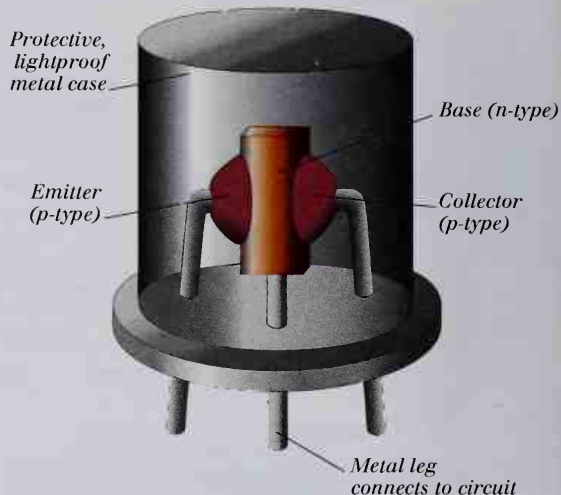

HOW TRANSISTORS WORK

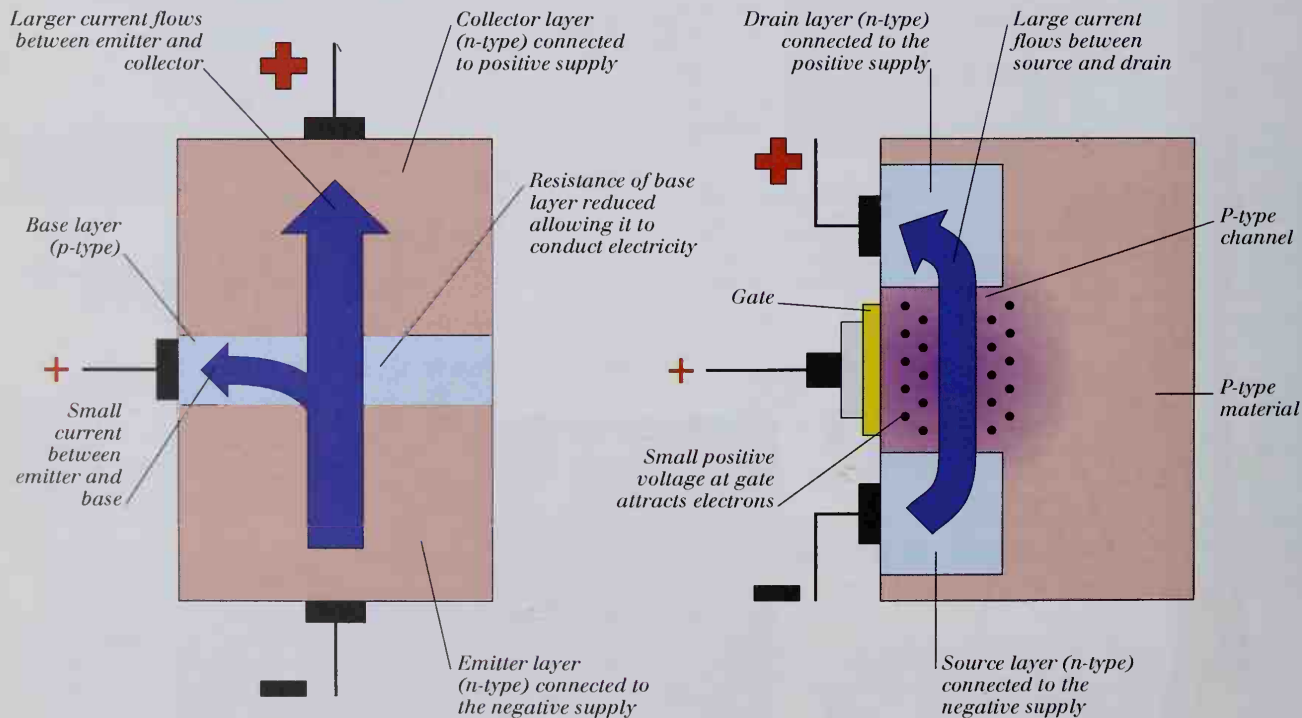

CROSS-SECTION OF A BIPOLAR TRANSISTOR (NPN)

When no current flows between the base and emitter of a bipolar transistor, no current can flow between the emitter and collector. When a small current flows between the base and emitter, it brings electrons to the base. This reduces the resistance of the base layer and enables a larger current to flow between the emitter and collector.

CROSS-SECTION OF A FIELD-EFFECT TRANSISTOR (MOSFET)

A small, positive voltage at the gate attracts electrons from the p-type material to the region (known as the channel) between the source and the drain. These electrons lower the resistance of the channel and enable a current to flow between the source and drain. In a JFET, the gate is on either side of the transistor.

EXAMPLES OF TRANSISTORS

Transistors are used in a wide range of applications, but their two main uses are amplification and switching. Bipolar signal transistors are often used to amplify low-level signals. Power transistors act as switches to turn large currents on or off using safer, low-voltage inputs. Thyristors are also used as switches, but once triggered into conducting electricity, they stay switched on without further input, just like a mechanical switch.



Case is bolted to a heat sink (device that absorbs heat)

MEDIUM-VOLTAGE-CONTROL TRANSISTOR



Tag indicates emitter leg

BIPOLAR SIGNAL TRANSISTOR



Plastic case

LOW-FREQUENCY BIPOLAR TRANSISTOR



Terminal connects to circuit

HIGH-CURRENT THYRISTOR

CIRCUIT SYMBOLS

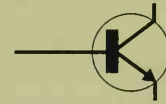

NPN TRANSISTOR



PNP TRANSISTOR

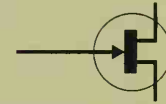

JFET TRANSISTOR

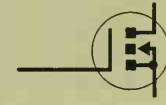

MOSFET TRANSISTOR

THE TRANSISTOR AS AN AMPLIFIER

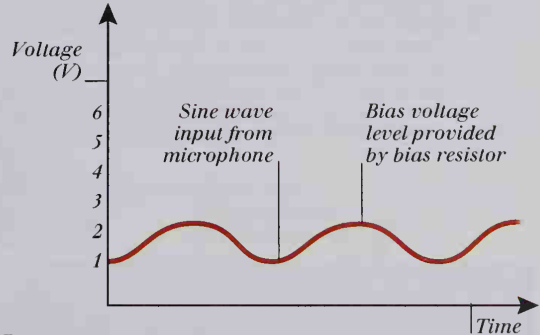
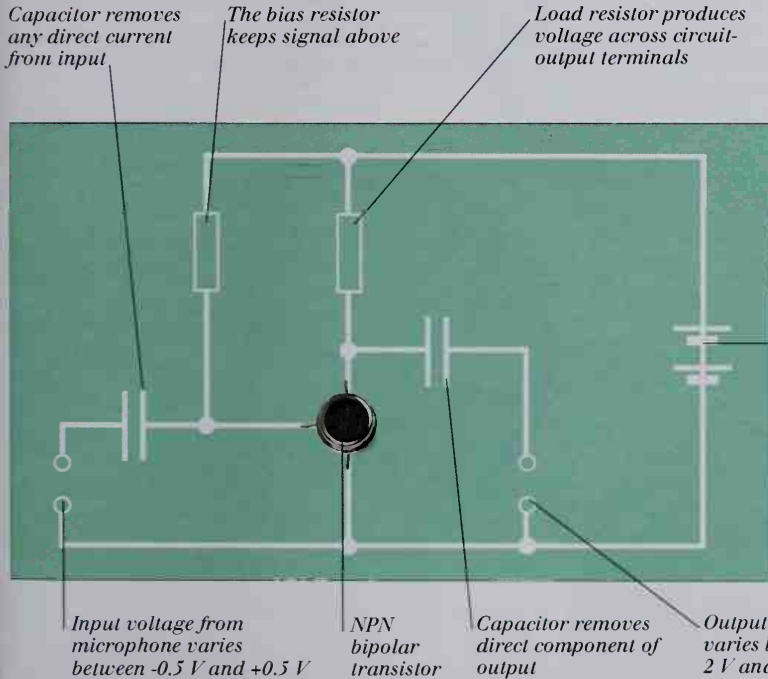

INPUT SIGNAL
A graph of the voltage at the base of the transistor shows that the input signal has an amplitude of about 0.5 V.

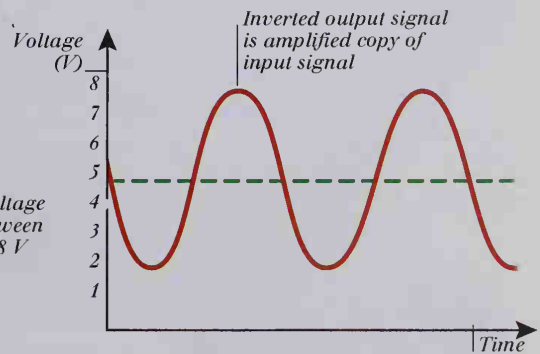

OUTPUT SIGNAL
The circuit's output is a varying voltage that is an amplified copy of the input signal - it has an amplitude of about 6 V.

SIMPLE AMPLIFIER CIRCUIT

An amplifier is a circuit or device that increases the **amplitude** of a signal. In the case of sound, this results in it being louder. In the circuit shown above, the input signal is a small, varying voltage from a microphone that produces a small, alternating current between a transistor's emitter and base. This small current allows a larger current to flow between the emitter and collector. This current flows through the load resistor and so produces a voltage across it. The voltage is an amplified copy of the input signal.

Integrated circuits

INTEGRATED CIRCUITS CONSIST of complete electronic circuits built onto a single slice of **semiconductor**, normally silicon. They can contain hundreds of thousands of linked components and yet may be as small as a fingernail. Such miniaturization has made possible personal computers, digital watches, and many other familiar electronic devices. Integrated circuits are also known as chips, microchips, or silicon chips. Electronic components, such as resistors, capacitors, diodes, and transistors, are formed within the silicon. Chips used in computers are called microprocessors and contain many transistors, which are used as switches. Transistor switches are ideal for handling the on or off electric currents that form the basis of computer logic (see pp. 370-371). The components are built up as layers of n- and p-type semiconductor (see pp. 346-347), formed within the silicon by a photographic process. The process of building layers is broken down into many stages of masking, doping, and etching. Aluminum tracks connect the many components together, just as copper tracks do on ordinary printed circuit boards (see pp. 338-339).

TRANSISTOR-SWITCH CIRCUIT

Microprocessors contain thousands of transistor switches. The simplified circuit shown below explains the operation of a switch using a field-effect transistor (see pp. 348-349). The input to the switch is from computer input devices or from previous digital circuits. When the input to the transistor's gate is low, there can be no current flow between the source and the drain. In this case, the output voltage will be equal to the supply voltage (high), because the load resistor drops no voltage when no current flows. When the input voltage increases above a certain level, the transistor switches on (current flows from source to drain), the load resistor drops most of the supply voltage, and so output drops to near zero.

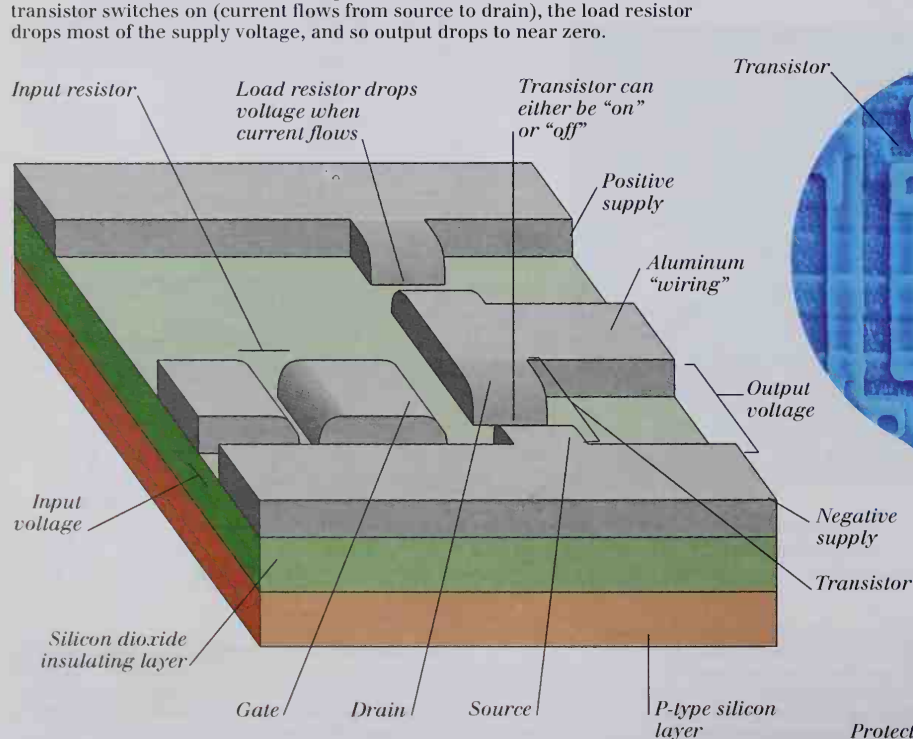

TYPES OF INTEGRATED CIRCUITS

The two main types of integrated circuits are digital and linear (or analog). Digital integrated circuits include microprocessors. Linear integrated circuits are often used as amplifiers, in audio equipment for example. The most common type of linear integrated circuit is the operational amplifier (op-amp).

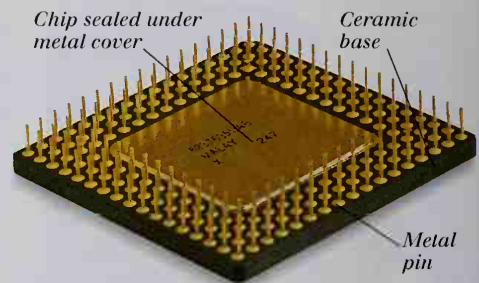

DIGITAL INTEGRATED CIRCUIT

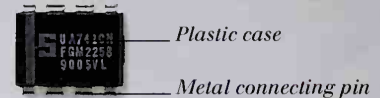

LINEAR (ANALOG) INTEGRATED CIRCUIT

MINIATURIZATION

Only through a microscope is it possible to see the thousands of tiny transistors and other components that can be put on one tiny slice of silicon to make a complete integrated circuit. The circuit is encased in ceramic or plastic for protection. A set of metal pins projecting from the case connects the integrated circuit to a circuit board.

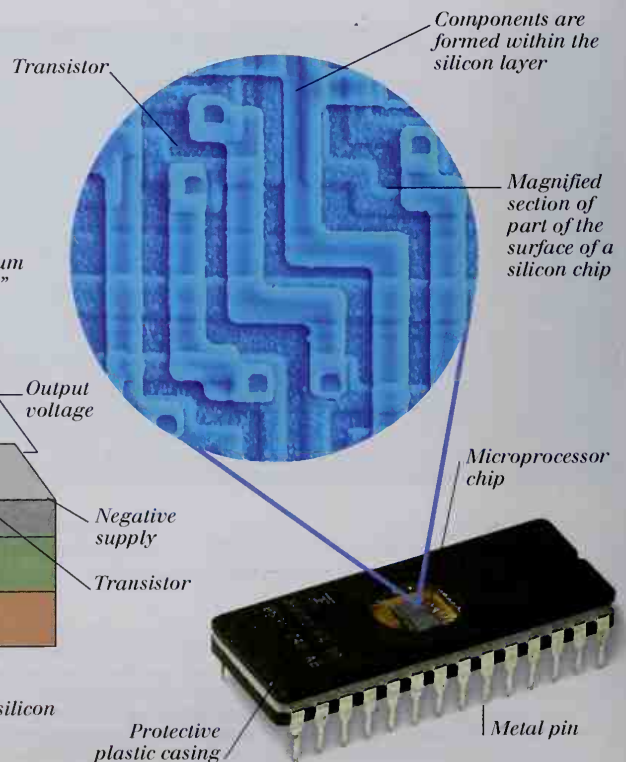

MAKING AN INTEGRATED CIRCUIT

Cylinders of pure, crystalline silicon are the starting point in the production of integrated circuits, a process known as very large-scale integration (VLSI). The crystal is sliced into a large number of circular wafers, and a few hundred microchips at a time are produced from each

wafer. Most of the process takes place in very clean conditions, as dust or other contaminants can ruin the chips during production. In a series of stages, n- and p-type silicon, polysilicon (a conductor), and aluminum "wiring" are laid down to form the circuit.

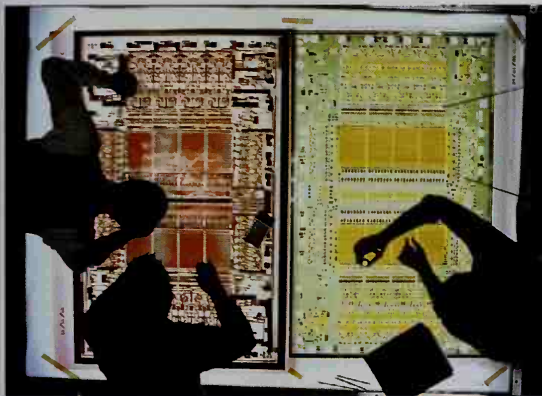

Designs for each layer have a different color

Transparent plastic sheet

Each square is a mask for one microchip

Control pattern used for testing

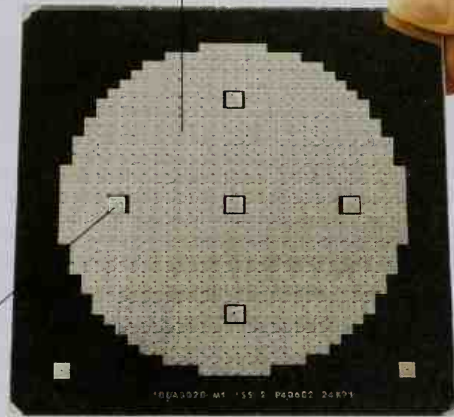

CIRCUIT DESIGN

An integrated circuit is built up as a series of n- and p-type layers. Each layer must be designed separately. For more simple circuits, transparent, enlarged plans are laid on top of one another to check that each layer fits precisely with all the others.

PHOTO MASK

The designs for each layer are reduced and reproduced to form a photo mask. Ultraviolet light is shone through the photo mask on to a wafer of silicon. The wafer has an insulating layer of silicon oxide, which is broken down where ultraviolet light falls on the oxide. The exposed areas are etched away by acid, and this leaves pure silicon exposed and ready to receive the next treatment.

DIFFUSION OF IMPURITIES

Once the appropriate areas of silicon dioxide have been removed by etching, the wafer is heated in the presence of doping elements. Atoms of these doping elements diffuse into the exposed silicon, forming n- or p-type regions. Further layers are built up by more masking, etching, and doping, until the components are complete.

P-type layer formed by doping

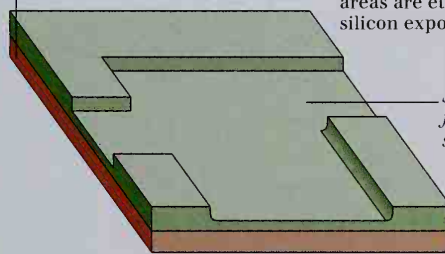

Silicon dioxide formed by heating silicon in oxygen

Silicon dioxide insulating layer



Workers operate in ultraclean rooms and wear gowns and gloves

Batches of wafers fed into furnace

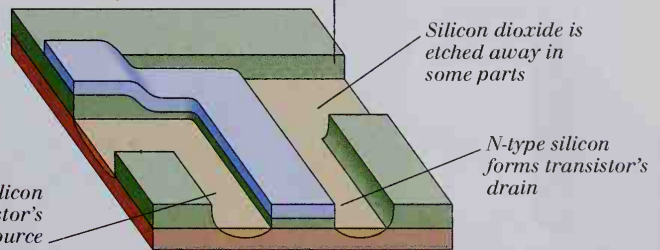

Aluminum connection to gate

Aluminum connection to source

Aluminum connection to drain

BUILDING UP THE LAYERS

A field-effect transistor is formed on the surface of an integrated circuit by building up layers of n- and p-type silicon, polysilicon, silicon dioxide, and aluminum. The finished transistor is just one thousandth of a millimeter wide.

Computers

AT THE HEART of the personal computer (PC) are microprocessors that perform mathematical operations using numbers in binary form (see pp. 360-361). The binary system uses only two digits, 0 and 1, called binary digits, or bits. These bits are expressed inside the computer in a number of ways: voltages that may be low (for 0) or high (for 1); transistor switches that may be off or on; or tiny capacitors (see pp. 342-343) that may be uncharged or charged. Alphanumeric characters (letters and numbers), as well as simple computer instructions, are represented by groups of eight bits, called bytes (see pp. 390-391). The main processor inside a computer is the central processing unit (CPU). This is a chip that carries out huge numbers of calculations every second. Software is a set of instructions that is needed to enable it to carry these out. The software and the results of the calculations must be stored inside the computer, and this is achieved by random access memory (RAM) and read-only memory (ROM).

CENTRAL PROCESSING UNIT (CPU)

All computers have a chip called the CPU. The CPU is the computer's center of operations. It takes in information from a keyboard or mouse, the RAM, and the ROM. It can also send data to the monitor (or other output devices) or to be stored in the RAM, but it cannot send information to the ROM. The content of the ROM is normally fixed – it cannot be altered or removed, and can only be read.

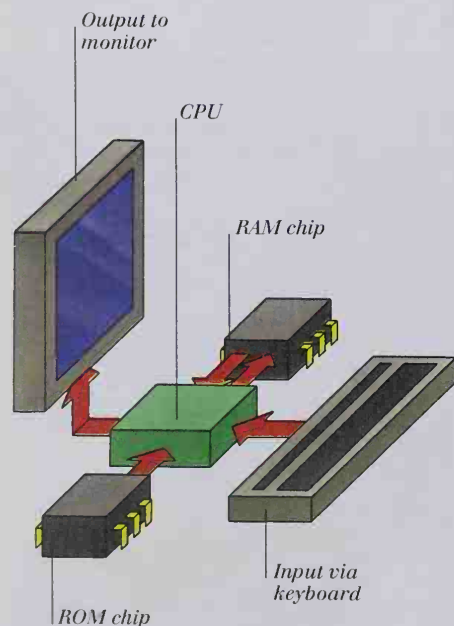

PERSONAL COMPUTER

PCs consist of three main parts: an input device (such as a keyboard); output device (such as a monitor); and the system unit, which houses the main electrical components.



HOW RANDOM ACCESS MEMORY (RAM) WORKS

Information stored in RAM is temporary; it is lost when the computer's power is switched off. Tiny capacitors on the RAM chip store binary digits. They are uncharged for bit 0, and charged for bit 1. The chip is covered with tiny crisscrossed metal tracks. Located at each intersection of these tracks is a transistor switch and a capacitor. To store information at a particular location, or address, pulses are sent along a set of tracks, called address lines. Within a particular address, there are normally 8 or 16 bits. Where a 1 is to be stored within the address, a pulse sent along a data line charges a capacitor.

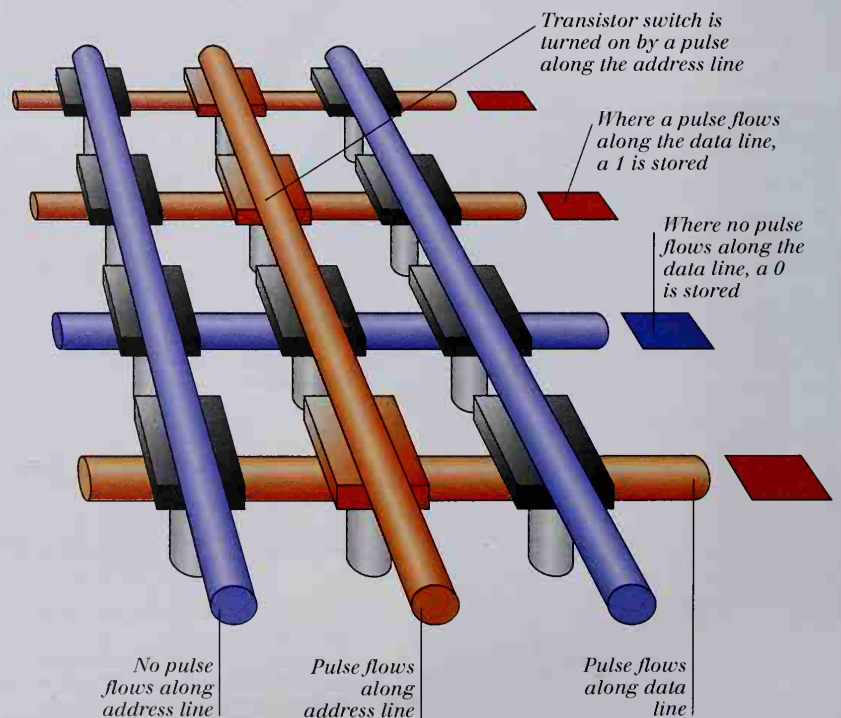

INSIDE A PERSONAL COMPUTER

The computer itself is normally housed in a hard disk unit. This has socket connections, called ports, that allow information to be input into the computer or read from it. Input and output devices, collectively known as peripherals, include keyboards, monitors, and printers.

Inside every CPU chip is an arithmetic unit, dedicated to carrying out addition and other logical operations. The rate at which these are carried out is a measure of the speed of the computer and is normally measured in megahertz (MHz, millions of calculations per second).



CD-ROM drive
 Floppy disk drive
 Hard disk housed in a strong protective plastic shell

HARD DISK UNIT

All of the computer's major subunits are housed in the hard disk unit. The CPU, RAM, and ROM chips are plugged into a motherboard, along with additional circuit boards, called cards, which extend the computer's capabilities. All the various cards and chips inside the unit are connected by buses. At the rear of the unit are sockets called ports. These enable the computer to be connected to input and output devices (peripherals), including the keyboard, printer, and monitor.

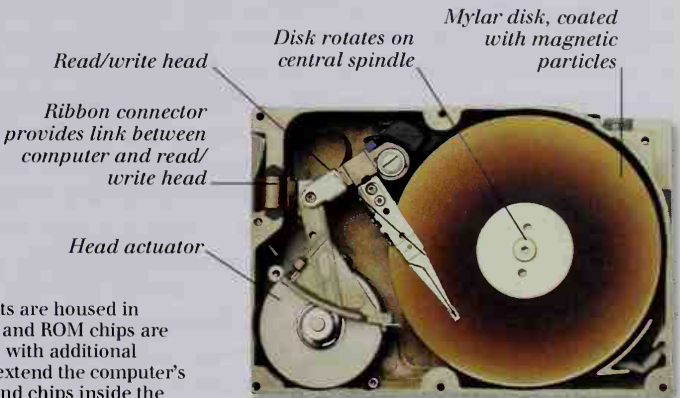

Read/write head
 Ribbon connector provides link between computer and read/write head
 Head actuator
 Disk rotates on central spindle
 Mylar disk, coated with magnetic particles

HARD DISK DRIVE

Information is stored magnetically on the surfaces of the disks inside a hard disk drive. It has read and write heads, which are positioned very close to the disk surface. The disks spin rapidly, and the heads move in and out to capture information from the disk.

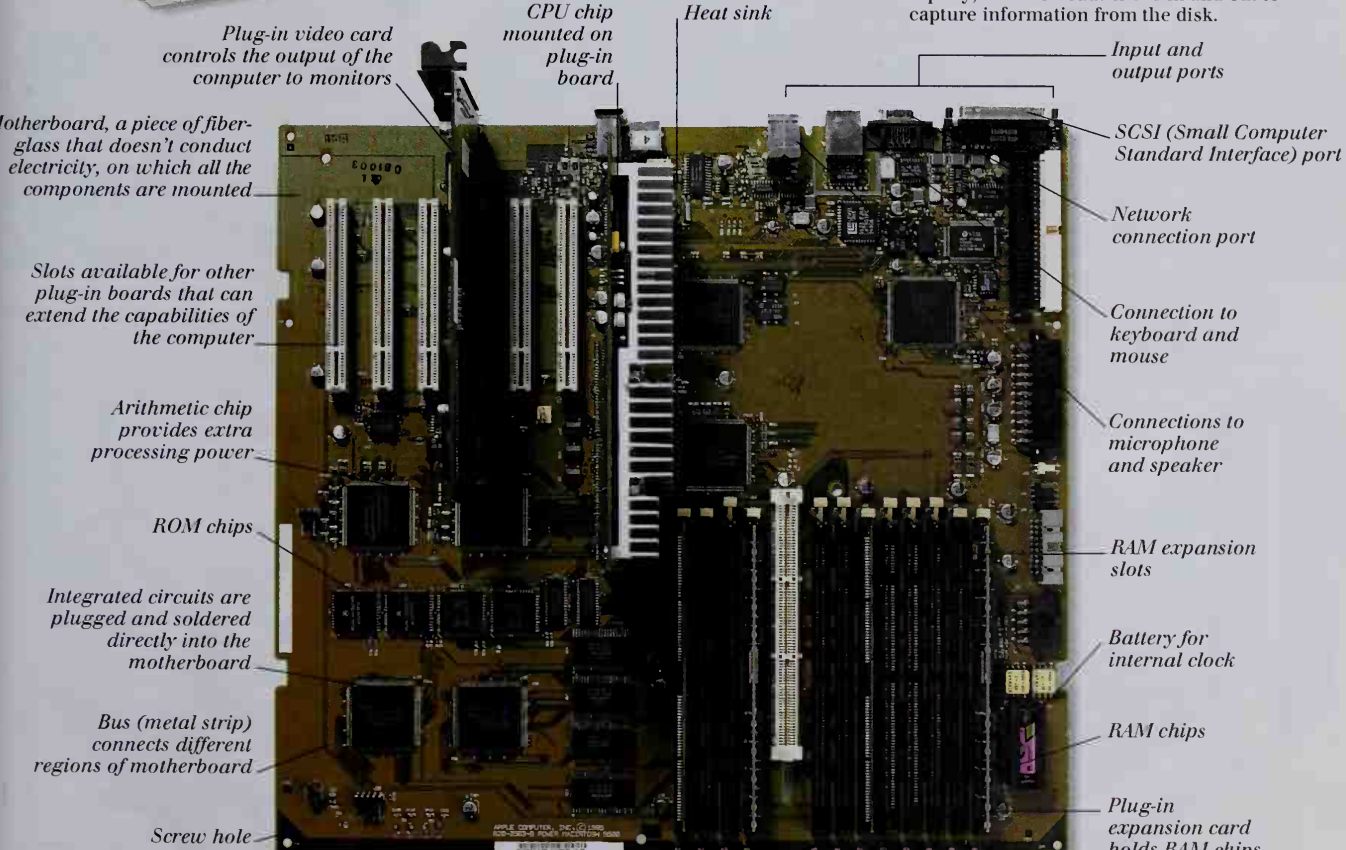

Plug-in video card controls the output of the computer to monitors
 CPU chip mounted on plug-in board
 Heat sink
 Input and output ports
 SCSI (Small Computer Standard Interface) port
 Network connection port
 Connection to keyboard and mouse
 Connections to microphone and speaker
 RAM expansion slots
 Battery for internal clock
 RAM chips
 Plug-in expansion card holds RAM chips
 Motherboard, a piece of fiberglass that doesn't conduct electricity, on which all the components are mounted
 Slots available for other plug-in boards that can extend the capabilities of the computer
 Arithmetic chip provides extra processing power
 ROM chips
 Integrated circuits are plugged and soldered directly into the motherboard
 Bus (metal strip) connects different regions of motherboard
 Screw hole

MOTHERBOARD

Metal tracks on the surface of the motherboard, called buses, carry information between the CPU, RAM, and ROM chips. They also connect the CPU to input and output ports, located at the rear of the unit. Extra circuit boards, called cards, can be plugged into the motherboard to extend the computer's capabilities.

Computer networks

A GROUP OF COMPUTERS CONNECTED TOGETHER sharing information is called a network. The information they share is digital, which means that it consists of long series of binary digits, or bits (see pp. 352-353). In addition to text and numerical information, pictures, sound, and video can be transferred over a network. Digital information passes between computers along cables, or in some cases through the air as radio waves or microwave radiation. Often, some of the network links are part of the telephone network. Most telephones are analog devices, and most telephone signals are therefore analog. For this reason, digital computer information is first coded (modulated) into an analog form so that it can be sent across the telephone network. At a computer receiving the information, it must be demodulated back to its original digital form. A device called a modem (modulator-demodulator) is used to link a computer to the telephone network. Computer networks can be linked to other computer networks, and by far the largest example of this arrangement is the Internet.

SAMPLING

In order to digitize analog sound signals to a high quality, an electronic circuit called an analog-to-digital converter measures (samples) the signal 44,100 times per second. The more samples per second, the more accurate the digital representation of the sound. Each sample is a numerical value, which is represented in binary form as a string of eight or sixteen bits. Large numbers of bits are needed to encode sound – for example, ten seconds of high-quality sound requires more than seven million bits.

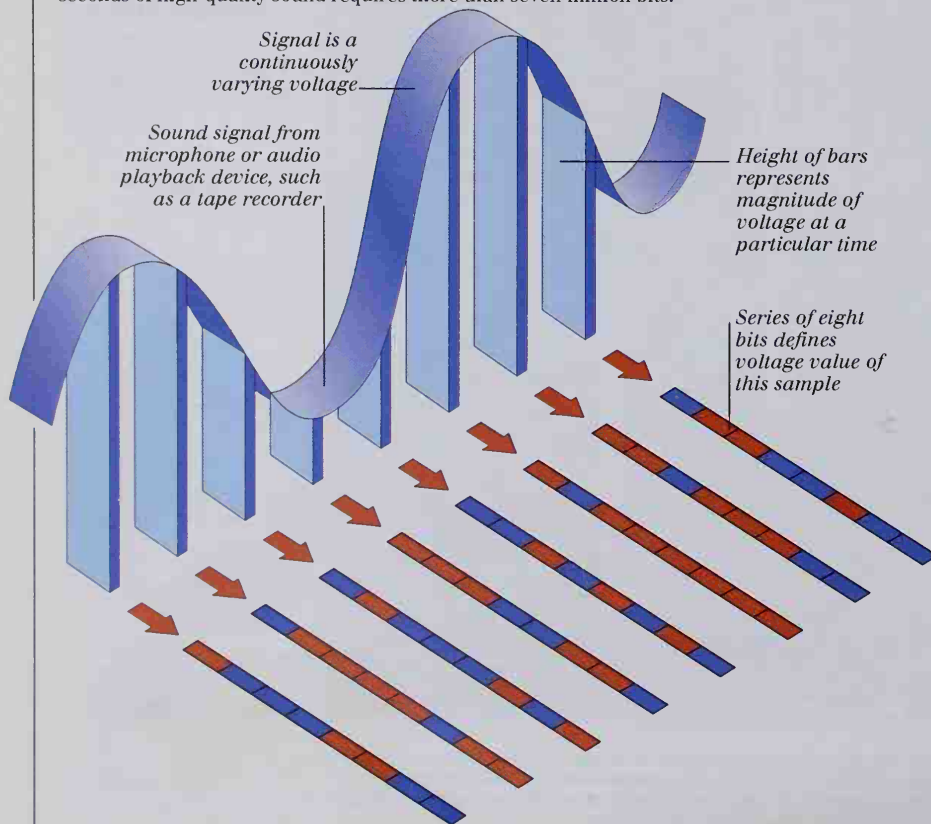

MOBILE MULTIMEDIA

A laptop computer provides access to computer networks from anywhere in the world via a mobile telephone. A plug-in modem the size of a credit card connects the computer to a telephone for fax communications, e-mail, and access to the World Wide Web.



CABLES

Three types of cable are commonly used to link computers across a network. Coaxial cable consists of one wire wrapped around another. A twisted pair consists of two insulated wires twisted around each other. The fastest links are provided by fiber-optic cables, which transmit digital information as pulses of light or infrared.

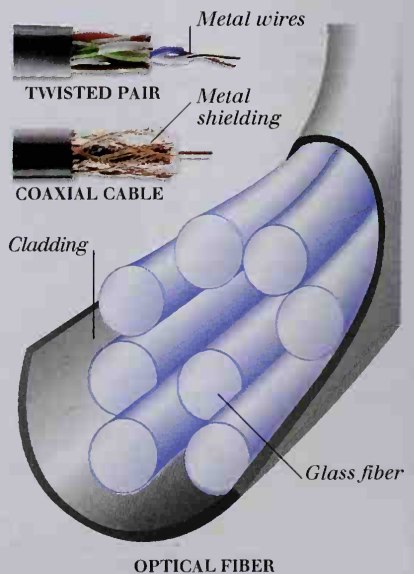

THE INTERNET

Powerful computers, called servers, are the points of connection to the Internet. Individual personal computers connect to servers via cables within a single building, or via a telephone link using a modem. Servers enable connected users to send and receive e-mail; they may also hold "pages" of information. There is a server at the heart of every LAN (Local Area Network); groups of LANs form WANs (Wide Area Networks).

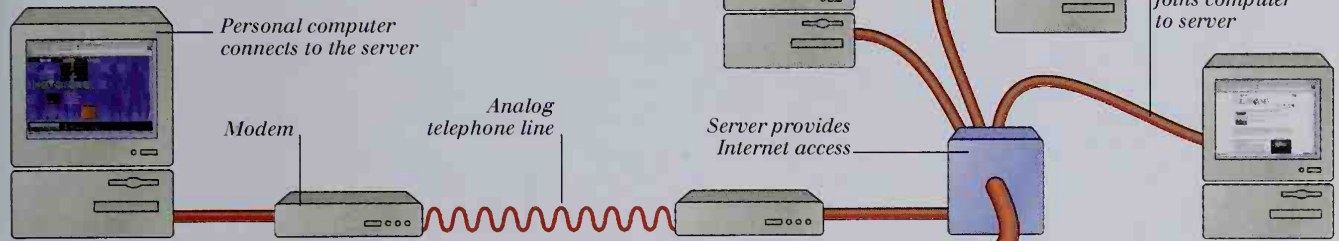

DIAL-UP CONNECTION

Most individual users of the Internet normally have a dial-up connection to an Internet service provider, via a modem. The modem converts digital information from the user's personal computer to an analog signal (see below), so that it can be sent down a telephone line. Another modem at the Internet service provider converts the information back into digital form.

High-speed cable provides fast connection to Internet backbone

SERVER

A server is a powerful computer that is constantly connected to many other computers. There is a server at the center of every computer network. Most servers are also connected to the Internet, providing access to e-mail and the World Wide Web for those connected to the network.



E-MAIL

One of the most useful applications of the Internet is electronic mail, or e-mail. Anyone with access to the Internet can send and receive e-mails to and from each other. Servers called mail servers are designed to process electronic mail, ensuring that it is delivered to the correct destination.

WORLD-WIDE WEB

Most servers contain information, stored electronically as "pages." This can be accessed by users of the Internet and forms a complex, interconnected "web" of information. Web pages carry a wide range of information, including news and commercial advertising.

"Firewall" restricts outside users' access to server

Server at the heart of the intranet

Computer linked to the business network

INTRANETS

Many large organizations have internal computer networks called intranets. Often the server at the heart of an intranet gives connected users limited access only to the Internet, such as e-mail capability only. This limited Internet access is often called a firewall.

MODEMS

A modem creates a rapidly changing analog signal, which carries digital information with it. The digital information is broken into groups of two, three, or more bits ("0" or "1"). Different combinations of bits change the frequency, amplitude, or phase of the analog signal. The digital information is decoded at the other modem.

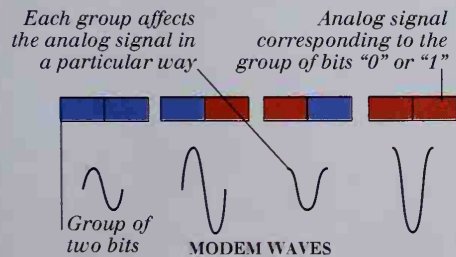

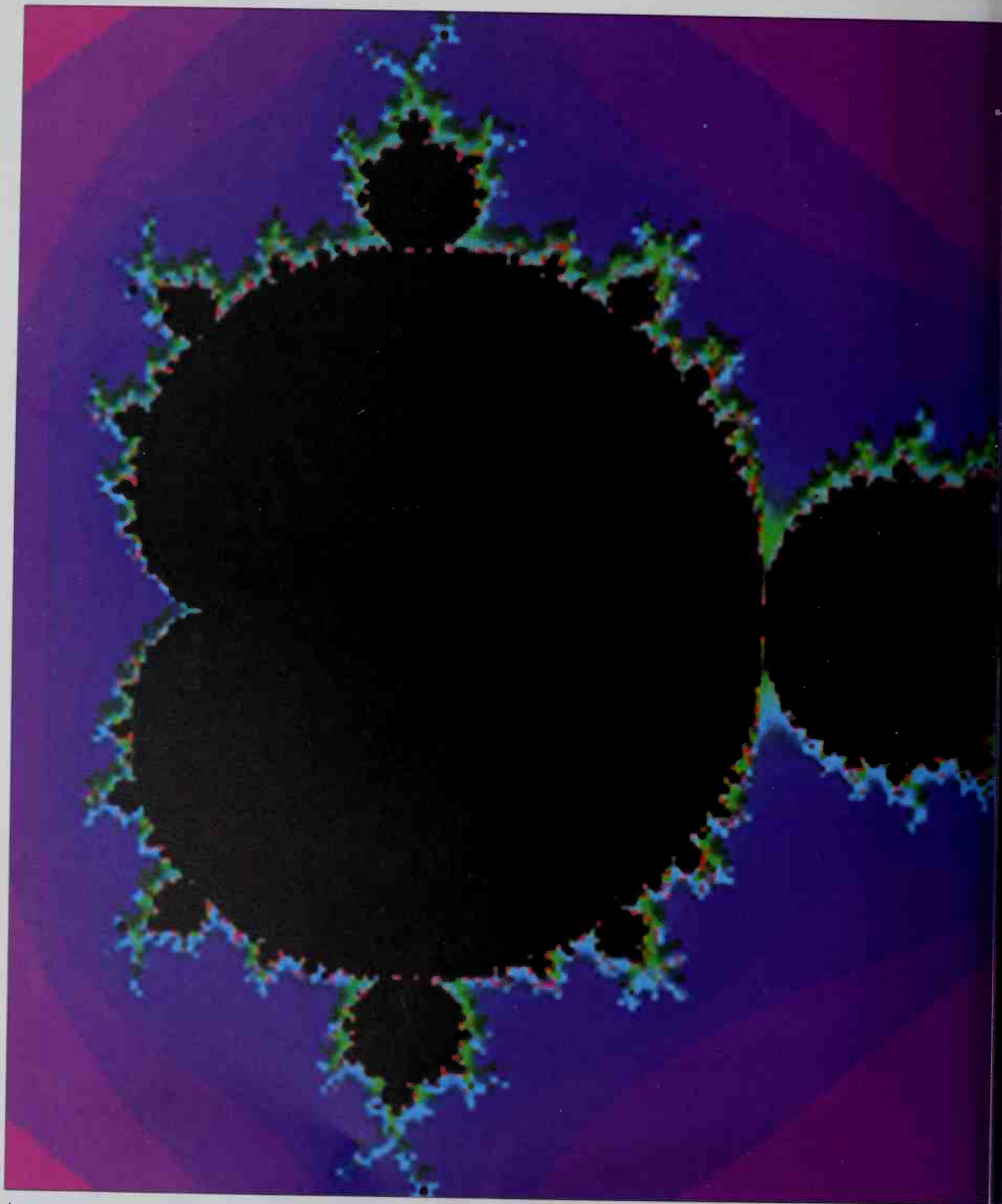

A computer-generated fractal image constructed using the Mandelbrot set of numbers

MATHEMATICS

DISCOVERING MATHEMATICS	358
NUMBERS.....	360
ALGEBRA	362
GEOMETRY.....	364
COORDINATES AND TRIANGLES	366
PROBABILITY AND STATISTICS	368
LOGIC AND SETS	370
CHAOS THEORY AND FRACTALS	372

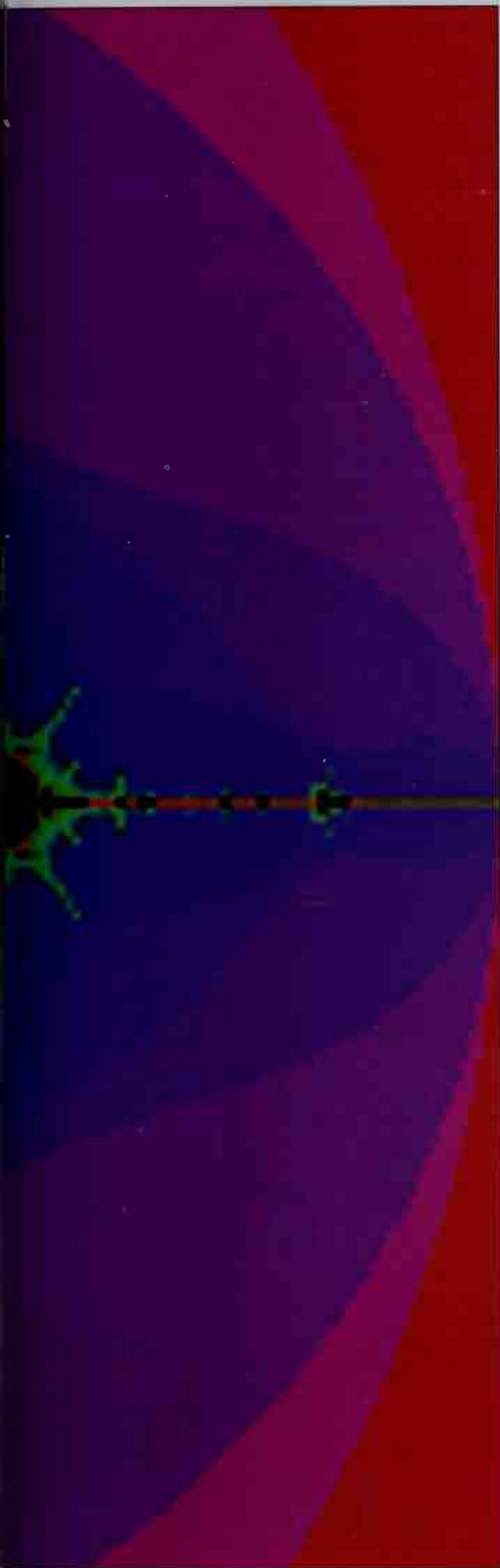
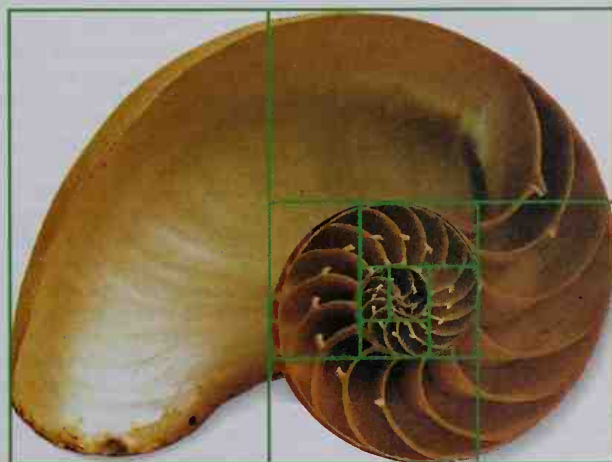

Discovering mathematics

THE STUDY OF MATHEMATICS is concerned with numbers and geometry. Numbers are used in arithmetic, probability theory, statistics, and in algebra. Geometry deals with shapes and curves. Algebra and geometry are combined in a branch of mathematics known as coordinate geometry, in which shapes may be described in terms of numbers. Modern mathematics includes non-Euclidean geometry, set theory, and chaos theory.

PURE AND APPLIED MATHEMATICS

Even before written language developed, numbers were recorded as tally marks, and simple calculations were applied to activities such as trade and surveying. From around 3000 BC, ancient Egyptian scribes were applying arithmetic to the construction of the pyramids. Being very practical, the ancient Egyptians had no desire to prove or to generalize their mathematical ideas. Mathematicians in Mesopotamia, however, were beginning to ponder on the fundamental and rather abstract nature of numbers and shapes – part of what is now called pure mathematics. The distinction between pure and applied mathematics persists today.

MATHEMATICS IN ANCIENT GREECE

Around 600 BC, Greek philosophers, astronomers, and mathematicians began to produce generalized mathematical statements (theorems). They saw the need to take a logical approach to the subject and to provide proofs for their theorems. For example, what later became known as the Pythagorean theorem had been known for centuries in China, but was first proved by the Pythagorean school in Greece. Through their logical approach, the Greeks developed a deeper understanding of pure mathematics. Ancient Greek mathematics is characterized by logic and by its investigations of geometry. For example, Greek astronomers estimated the diameter of the Earth and proved that it was round by using geometrical techniques. Greek mathematics was built up from basic statements called axioms, or postulates (such as “the shortest distance between two points is a straight line”). The Greeks arrived at their theorems by assuming the truth of postulates and applying logical arguments. The most important contribution to this process was Euclid’s 13-volume work entitled *Elements*, which was a comprehensive collection of Greek ideas of geometry at the time.

MIDDLE AGES

Greek mathematics survived the Dark Ages because it was translated into several languages. Meanwhile, Indian and Mesopotamian mathematicians made important contributions to arithmetic. For example, Indian mathematicians implemented the number zero, which had also been discovered, but not used, by the Maya of Central America some centuries earlier. **Muhammad ibn-Musa al-Khwarizmi**, the 9th-century Islamic mathematician, wrote many books, including *The Book of Restoring and Balancing*. The Arabic word for restoring is *al-jabr*, and this is the origin of the modern term “algebra.” By the 15th century, the focus of activity had moved to Europe, and although Chinese, Japanese, and Korean mathematicians made important discoveries during this period, their work was not known outside Eastern Asia until the 17th century.

EUROPEAN MATHEMATICS

Latin translations of Greek and Arabic mathematics reached Europe between the 11th and 15th centuries. Many of the mathematical symbols familiar today originated in Germany in the 15th century, while Italian artists made important advances in geometry in their studies of perspective during the 16th century. The 17th and 18th centuries saw a fresh approach to much of the mathematics that had been passed down from the Greeks and Arabs. For example, the ancient Greeks thought of the number 1 as the indivisible basis of all numbers, and therefore saw fractions as ratios rather than numbers less than 1. Around 1585, European mathematicians began to write fractions as decimal numbers, as well as common fractions and ratios. Several fundamental branches of modern mathematics were invented during this period, an important example being coordinate geometry, in which



PASCAL'S CALCULATOR

Built in 1642, Pascal's calculating machine consisted of a number of toothed wheels. The wheels were connected to concentric rings on which were inscribed numbers. Numbers to be added or subtracted were dialed in, and the answer appeared in holes to the left of the rings.

geometrical shapes can be represented by sets of numbers called coordinates. Perhaps even more important than coordinate geometry is calculus, an immensely powerful branch of algebra developed independently by Isaac Newton and Gottfried Leibniz in the 1680s.

19TH-CENTURY MATHEMATICS

Despite the dominance of calculus, geometry was still studied extensively during the 17th and 18th centuries. Euclid had presented a set of basic postulates of geometry that were thought to be self-evident (therefore needing no proof). In the early years of the 19th century, it was discovered that the so-called parallel postulate is not self-evident and indeed is not true in all cases. This led to the development of non-Euclidean geometry – the geometry of curved spaces, such as the surface of a sphere. It has been useful in many important theories, including general relativity. Both pure and applied mathematics became more rigorous and abstract during the 19th century, and more and more powerful. During this time, mathematicians developed set theory, which is closely related to logic theory. Two important tools in set theory and logic theory

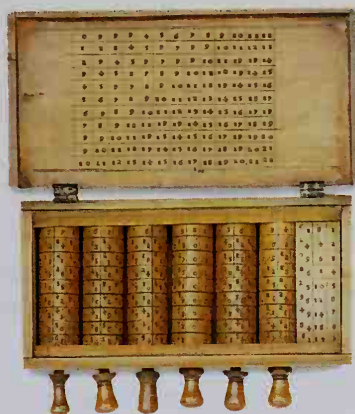

NAPIER'S BONES

In 1617, John Napier created a series of rods engraved with numbers in such a way that they could be set side by side and used to do complex calculations. The rods, which were usually made of ivory or bone, were soon known as "Napier's Bones."

were Boolean algebra and Venn diagrams. Boolean algebra is a system of notation that was important in the development of computers in the 1940s. The power of set theory and logic theory, together with a desire to understand the true nature of mathematics, led to an attempt to formulate all of mathematics using logic alone. This quest kept many of the best mathematical minds busy until around 1930, when Kurt Gödel published the first of his incompleteness theorems. These showed that the quest had been futile – that it was impossible to derive all of mathematics without making assumptions.

CHAOS THEORY AND FRACTALS

The second half of the 20th century saw the development of chaos theory. In the 1890s, Jules Henri Poincaré noted that while the orbits of two objects (such as the Sun and the Earth) could be figured out easily, adding a third orbiting object to the model could cause all three orbits to become surprisingly unpredictable. This three-body problem was the first realization of the importance of the mathematics of unpredictability – chaos theory. During the 1960s and 70s, Benoit Mandelbrot defined a new type of geometry, which was found to be related to chaos theory. He coined the term "fractal" – from the phrase "fractional dimension" – to describe the new geometry. The relationship between chaos theory and fractals is enabling mathematicians to gain a deeper understanding of complex and unpredictable systems, from the weather to the stock market.

TIMELINE OF DISCOVERIES

	8000 BC	People in Mesopotamia use clay tablets to record numbers of animals and measures of grain
Positional notation (place-value system) is developed by the Sumerians	2400 BC	
	1900 BC	Mesopotamian mathematicians produce what is now known as the Pythagorean theorem
Decimal numbers are first used, in China	1350 BC	
	900 BC	The symbol for zero is first used, in India
Euclid writes <i>Elements</i> , the standard geometry textbook for the next 2,000 years	300 BC	
	250 BC	Apollonius of Perga defines several important geometrical figures in terms of slices through a cone
Negative numbers are used for the first time, in China	100 BC	
	AD 1	Decimal fractions first used in China
Arabian mathematician Muhammad ibn-Musa al-Khwarizmi writes several works on algebra. The word "algebra" is derived from the title of one of his books	AD 800	
	1000	The decimal system of numbers is introduced into Europe by Arab mathematicians
Dutch mathematicians use the symbols "+" and "-" for the first time in their modern sense	1514	
	1614	John Napier introduces logarithms. They greatly improve speeds of calculation
Analytical geometry developed independently by René Descartes and Pierre de Fermat	1650s	
	1660s	English draper John Graunt lays the foundations of statistics by analyzing birth and death records
Isaac Newton and Gottfried Leibniz develop calculus independently	1660s-70s	
	1850s	Non-Euclidean geometry is developed
Georg Cantor and others develop set theory	1870s	
	1960	IBM researcher Benoit Mandelbrot develops fractal geometry, including devising the Mandelbrot Set
Chaos theory is used to analyze a number of different complex systems	1980s	



ELLIPSOGRAPH

This ellipsograph is a device that was used to draw perfect ellipses. The user was required to set the two foci of the ellipse and then establish the ellipse's boundary (distance from the center point of a line between the two foci). It was made in 1817 by John Farey of London.

Numbers

MATHEMATICIANS USE MANY types of numbers. The most basic is the class of numbers called counting numbers – **whole numbers** greater than zero. When counting, we use a number system based on the number 10, called the denary system, which evolved independently in many different cultures. Although the modern number system is based on the number 10, any number can be expressed using any **base**. Binary numbers are based on the number 2, for example. For any given number, there are always other numbers greater or less than it. Also, there are always numbers between any two numbers, however close those two particular numbers may be in value. These facts make it possible to construct a number line, which extends to infinity either side of zero. Fractions have values between those of whole numbers. They may be expressed as the ratio of two whole numbers (common fraction), as a number with a decimal point (decimal fraction), or as a percentage. Other types of number include irrational numbers, squares, and cubes.

NUMBER SYSTEMS

The digits 0-9 have evolved over many centuries (see below). The modern number system is a place-value system. This means that the value of any digit depends on its position in a number. For example (reading from left to right), in the number 553, the first three is worth 300, the second is worth 50, and the third is worth three.

1 2 3 4 5

MODERN NUMBERS

I II III IV V

ROMAN NUMERALS

▼ ▼▼ ▼▼▼ ▼▼▼▼ ▼▼▼▼▼

BABYLONIAN NUMBERS

۱ ۲ ۳ ۴ ۵

ARABIC NUMBERS

DENARY SYSTEM

The denary system is referred to as base ten, because it has ten symbols (0 to 9). An abacus uses beads to represent numbers in base ten – a bead on one row is worth ten times more than a bead on the row above. The abacus below shows the number 206,243 using 17 beads.

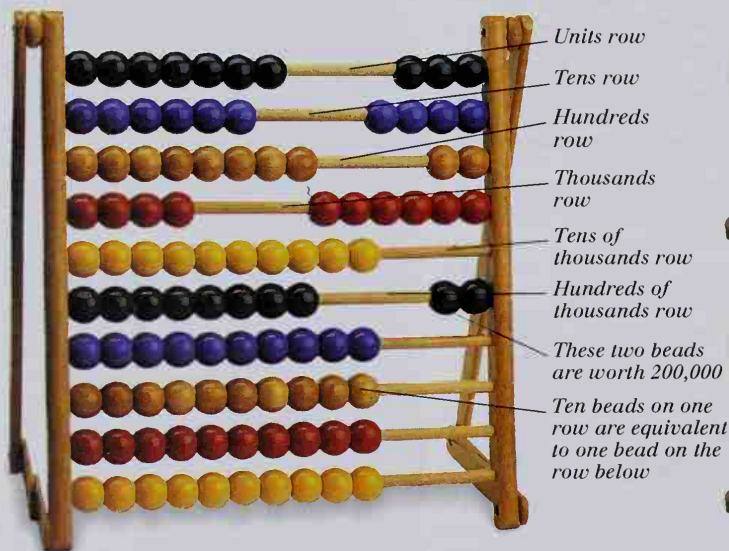

BINARY NUMBERS

Binary numbers use two digits (0 and 1). A two-state system, such as a light bulb, can be used to represent a binary number. The light bulbs represent, from left to right, eight, four, two, and one. The binary number 1010 equals ten ($8+0+2+0$), and 1001 equals nine ($8+0+0+1$).

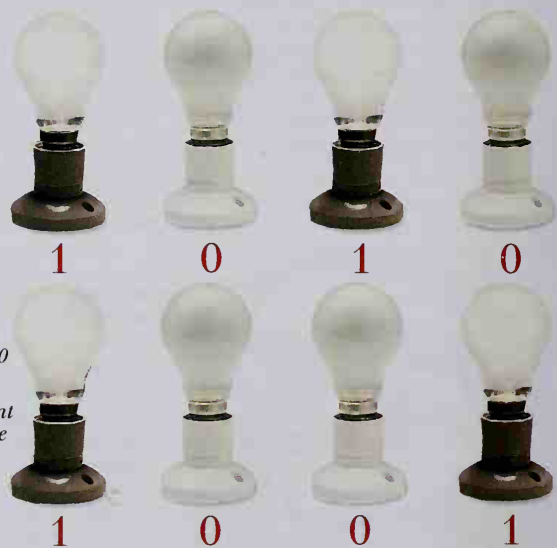

NUMBER LINE

All whole numbers greater than zero are called positive numbers. Negative numbers are those less than zero and are written with a negative sign (-). Positive and negative whole numbers are called integers. The numbers between them (non-integers) are fractions.

The number -1 is a negative integer

Zero is at the center of the number line

The number 2.4 is a fraction that lies between 2 and 3

The number 4 is a positive integer

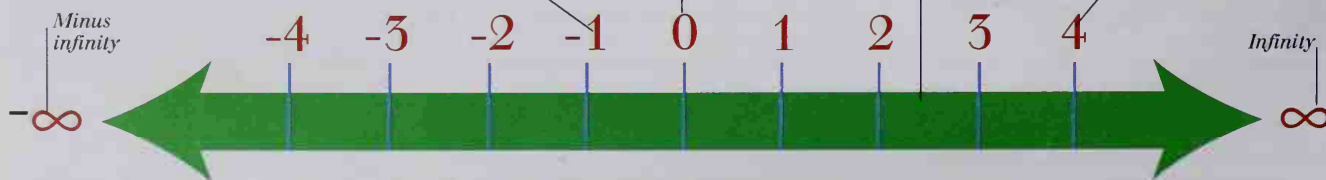

FRACTIONS AND PERCENTAGES

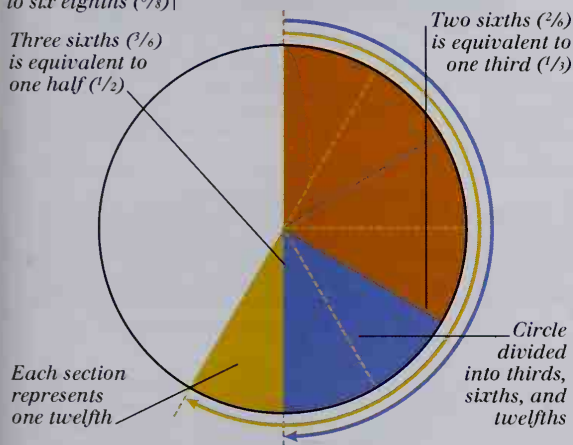
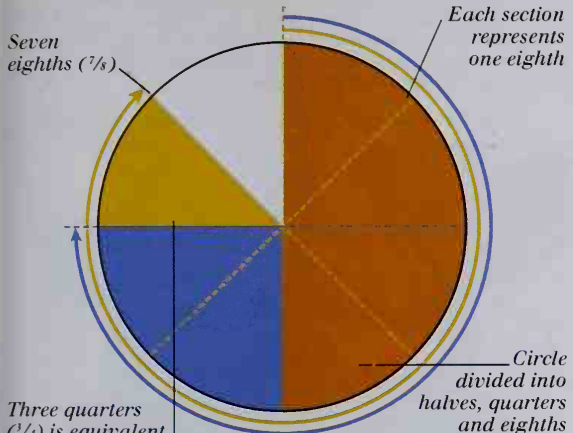

FRACTIONS
Common fractions are written as a ratio of two numbers. For example, the number that has exactly half the value of 1 is written $\frac{1}{2}$, because it is equal to 1 divided by 2. The number above the line is called the numerator, while the number below it is called the denominator.

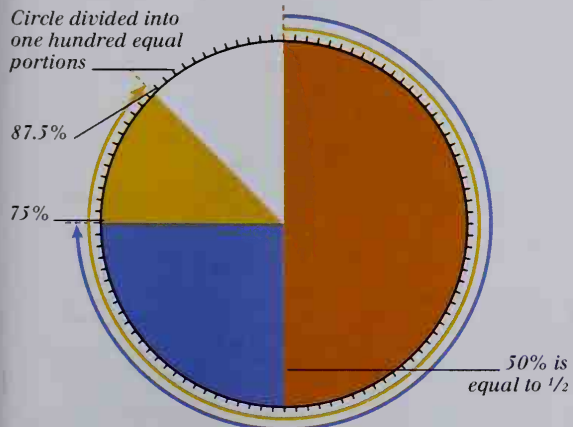

PERCENTAGES
Fractions can also be written as decimal numbers or percentages, with each digit having a value one tenth of the digit to its left. So, the fraction 0.66 is six tenths and six hundredths. It is equivalent to $\frac{66}{100}$, which can also be written as 66% (66 percent).

IRRATIONAL NUMBERS

Irrational numbers cannot be written down exactly as integers or fractions. They are important because they are needed to express certain scientific theories mathematically. An example is the golden ratio, approximately equal to 1.618:1. A rectangle having sides in this ratio is called a golden rectangle and is found commonly in nature, art, and architecture. The golden rectangle can be used to construct a logarithmic spiral (see below) in the shape of this nautilus shell.

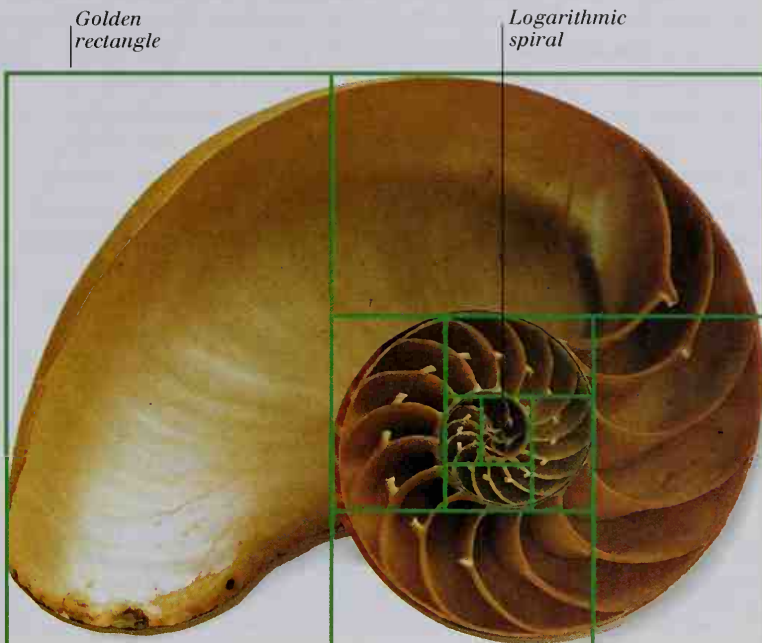

SQUARES AND CUBES

The square of a number is that number multiplied by itself. Similarly, the area of a square is found by multiplying the length of one side by itself. The area of the face of a cube that has sides three units long (see below) is therefore nine units. Nine is the circle of three and can be written as 3^2 . A cubic number is a number that is multiplied by itself, and then by itself again. This process is called cubing because it yields the volume of a cube. The volume of the cube below is therefore twenty-seven units. Twenty-seven is the cube of 3 and can be written as 3^3 .

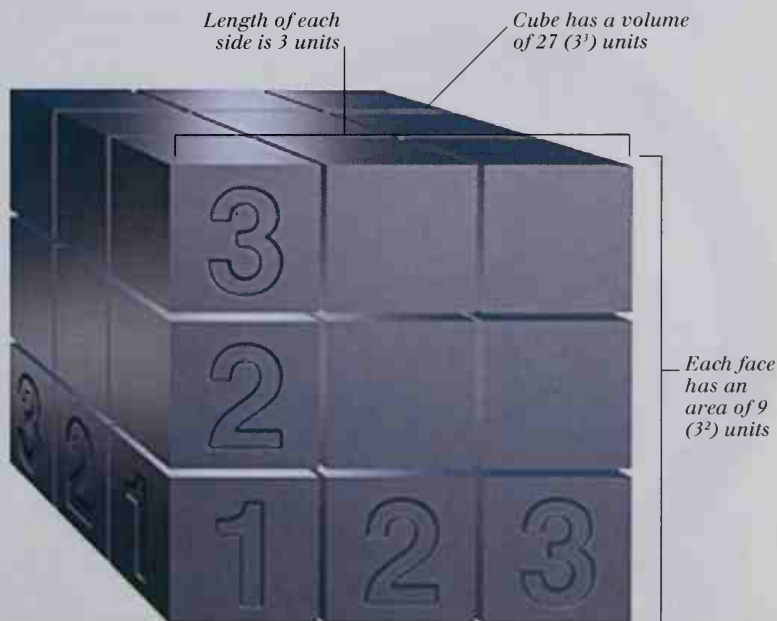

Algebra

THE BRANCH OF MATHEMATICS in which numbers are represented by letters or other symbols is called algebra. Algebraic expressions are normally in the form of an equation involving constants and variables. By definition, the values of both sides of an equation must be equal. Alternatively, an expression may be an inequality, such as one involving the symbol ">", which means "greater than" (see pp. 392-395). Equations that relate the values of one variable to the values of another (or several others) are called functions. Among the most useful functions are polynomials, which involve variables raised to various powers. When a number or variable is squared (see pp. 360-361), it is said to be raised to the second power; if it is cubed, it is said to be raised to the third power. Algebraic formulas are used to describe phenomena in all scientific disciplines. For example, the motion of a projectile can be summarized by a formula that relates speed, time, and distance to the rate of acceleration due to gravity.

CONSTANTS AND VARIABLES

Algebraic expressions involve constants (fixed numbers) and variables (which can take many different values). For example, the area of any circle is always related directly to its radius. In the equation below, a and r are variables used to denote the area and radius respectively, and π (pi) is a constant whose value is about 3.14. This equation expresses a relationship, or function, between area and radius.

Equals sign means squared (multiplied by itself)

$$a = \pi r^2$$

a is a variable

π is the ratio of the area of the circle to the radius of the circle

The circumference, C, of the circle can be figured out from another simple equation, $C = 2\pi r$

Radius, r

Like every circle, the wheel has an area equal to π multiplied by the square of its radius

ALGEBRAIC EQUATIONS

The scales below are balanced with eight eggs in one pan and a 400g mass in the other. Assuming that each egg has the same mass, then the mass of each egg must be 50 g (400 g divided by eight). In a similar way, algebraic equations can be used to find the value of unknown numbers.

Eight identical eggs

400-g mass

$$8x = 400$$

$$400 \div 8 = 50$$

$$x = 50$$

If 8x is equal to 400, x must be equal to 400 divided by 8

PICTURING ALGEBRA

When several values of the function $y = 4 - x$ (see table) are plotted on axes, they lie in a straight line. Inequalities can also be shown on graphs. For example, the shaded area in the graph below is the region for which the following inequalities are true: $y < x$, $y < 4 - x$, $y > 0$ (> means "greater than," < means "less than").

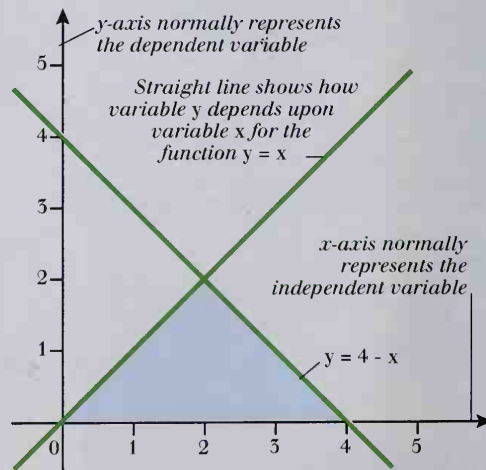

GRAPH OF FUNCTION $Y = 4 - X$

Variable y is always equal to $4 - x$, whatever the value of x

When $x = 1$, $y = 3$

x	0	1	2	3	4
$4 - x$	4	3	2	1	0

TABLE OF VALUES OF $Y = 4 - X$

GRAPHS OF POLYNOMIAL FUNCTIONS

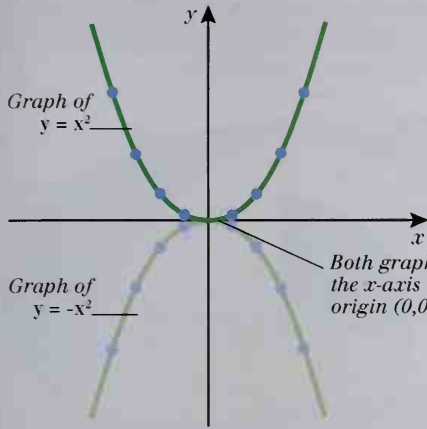

QUADRATIC CURVE

A function involving powers (see pp. 360-361) of a variable no higher than two is said to be a quadratic. Here, the two simplest quadratics are plotted: $y = x^2$ and $y = -x^2$. The resulting curves are parabolas.

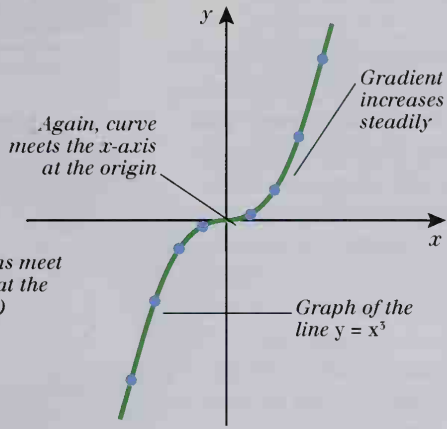

CUBIC CURVE

A function involving the cube (see pp. 360-361) of a variable is called a cubic. The simplest cubic function is $y = x^3$. A cubic can contain terms of x^2 and x as well as x^3 , but the shape of the graph is not as simple as that shown here.

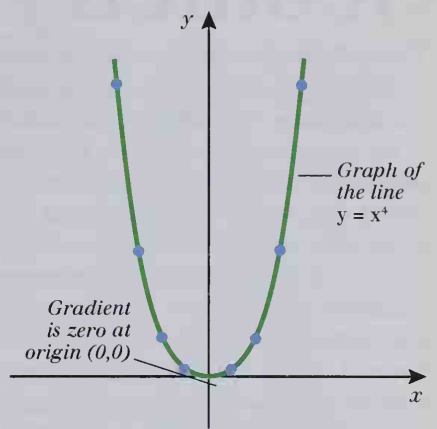

BIQUADRATIC CURVE

Functions involving the fourth power of a variable (for example x^4) are called biquadratic. This is a graph of the simplest biquadratic curve, and it has a shape similar to a quadratic curve but with steeper gradients.

FORMULAS

Scientists regularly develop and use formula that describe or predict the dependence of two or more variables. Here, a ball is fired vertically upward from a truck that is moving at a constant speed. A formula figured out from the known laws of motion (see pp. 20-21) shows that the height, h , of the ball above the truck is equal to $ut - \frac{1}{2}gt^2$. (In this

equation, u is the initial vertical velocity of the ball, g is the acceleration due to gravity, and t is the time elapsed after the ball is fired.) The formula is a quadratic equation (see above), and a graph of h versus t has the shape of a parabola (as does the path of the ball).

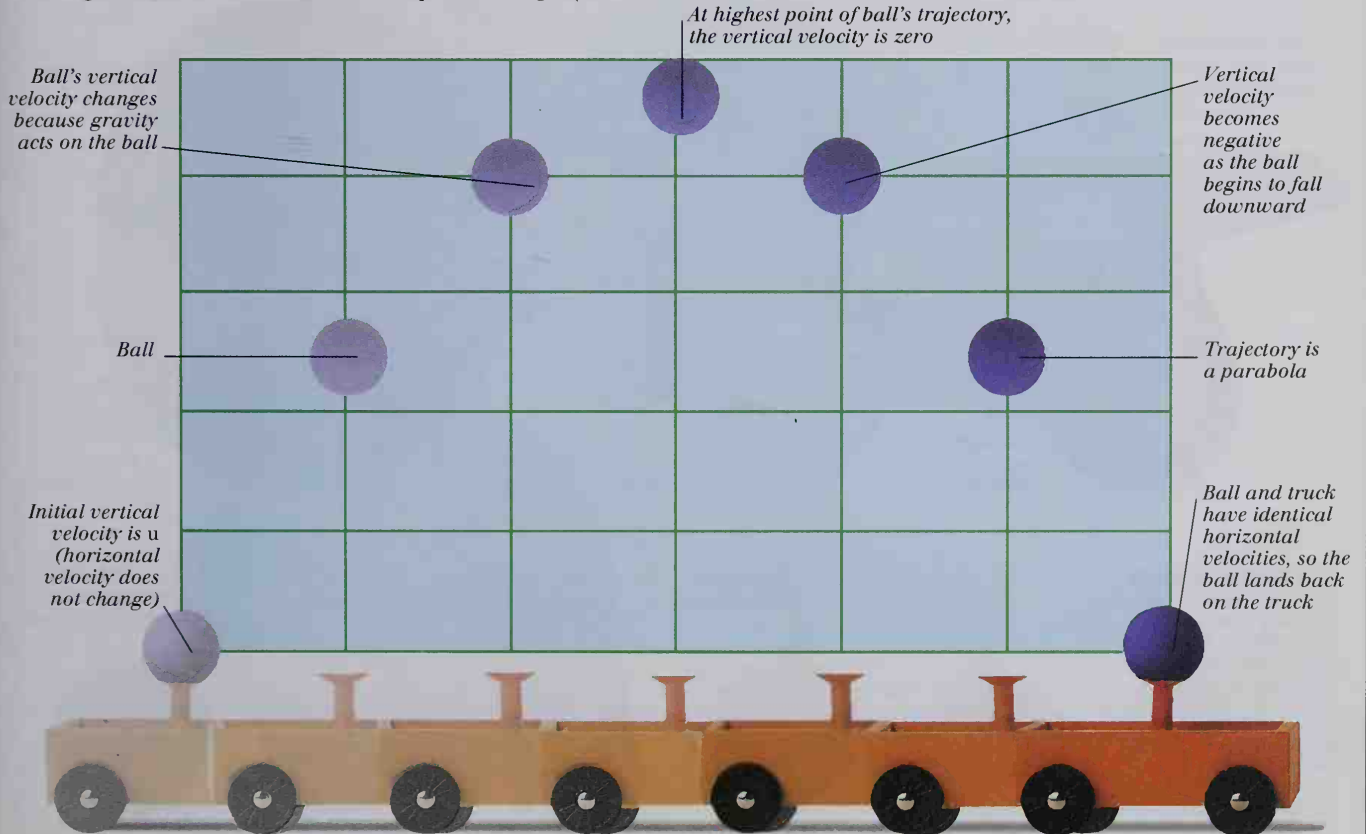

Geometry

THE STUDY OF SHAPES, LINES, and the space that they inhabit, is called geometry. Two-dimensional shapes, such as circles, are said to be flat, while three-dimensional shapes are said to be solid. Among the most familiar flat shapes are simple polygons, which have straight sides. Solid shapes include polyhedra, which have a polygon at each face. Mathematicians generally refer to lines as curves, the shapes of which are described in a branch of geometry known as coordinate geometry (see pp. 366-367). In addition to the study of shapes and curves, geometry looks at the nature of space itself. The ancient Greek mathematician Euclid (see p. 295) published a set of axioms (rules) that originally applied to all shapes in space. Non-Euclidean geometry is the study of those spaces for which Euclid's axioms do not apply. For example, the theory of general relativity (see pp. 62-63), in which space is seen as curved, makes use of non-Euclidean geometry.

FLAT SHAPES

Two-dimensional shapes are called flat shapes. They include circles, squares, and triangles. Flat shapes constructed with straight sides only are called polygons, and are categorized according to the number of sides they have. For example, all polygons with three sides are triangles, and all polygons with four sides are quadrilaterals. A polygon that has sides of equal length and internal angles of equal size is said to be regular. A square, for example, is a regular quadrilateral.

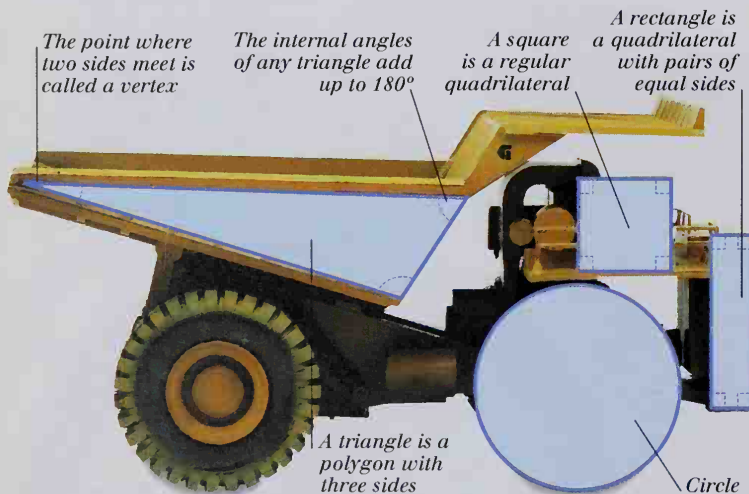

CIRCLE

The distance from the center of a circle to its circumference is called the radius and is equal to half the circle's diameter. Dividing a circle's circumference by its diameter results in an irrational number, (π), which is the same for every circle and is approximately equal to 3.14.

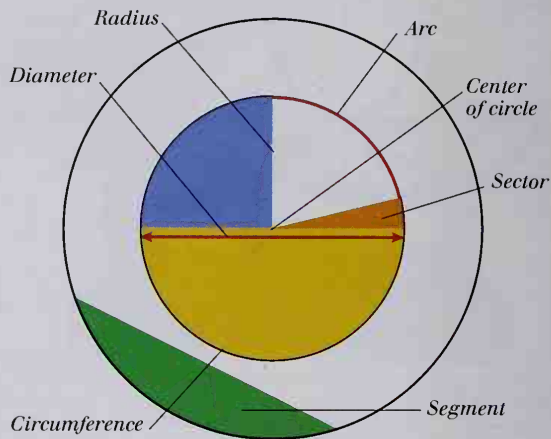

SPHERE

All points on the surface of a sphere lie at the same distance from the center. As with a circle, this distance is the radius, which is equal to half the sphere's diameter. Slicing the sphere through the diameter splits the sphere into two equal hemispheres. The flat surface of a hemisphere is a circle.

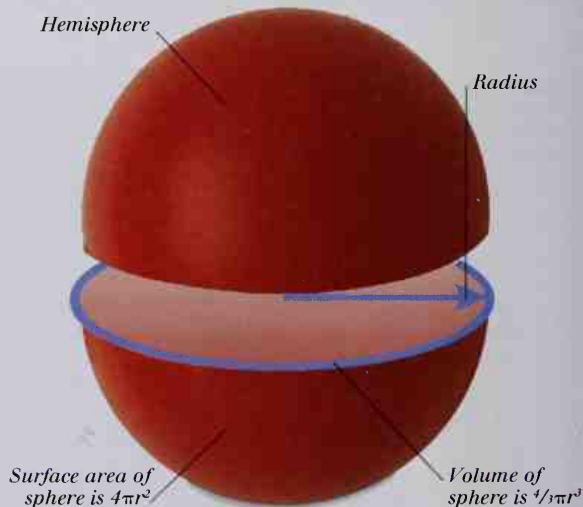

PLATONIC SOLIDS

Three-dimensional shapes are called solid shapes. They include spheres, cubes, and pyramids. Solid shapes with a polygon at each face are called polyhedra. Regular polyhedra have a regular polygon at each face. There are just five regular polyhedra, all of which are shown here.

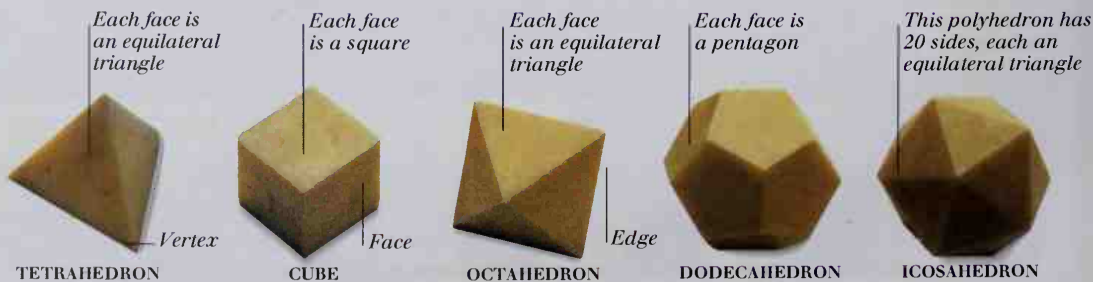

MÖBIUS STRIP

The Möbius strip is an interesting topological figure. It is formed by putting a single twist in a two-sided, two-edged strip and then attaching the two ends of the strip. It has strange properties, including having only one face and one edge.



Tracing along one side of the band covers both sides of the original strip

CONIC SECTIONS

The surface of a cone is at a fixed angle to the cone's axis. This angle is called the generating angle. Slicing a cone at an angle equal to the generating angle produces a curve called a parabola. At an angle less than the generating angle, a hyperbola is produced, while an ellipse results from a slice at greater than the generating angle. Cutting a cone parallel to its base produces a circle.

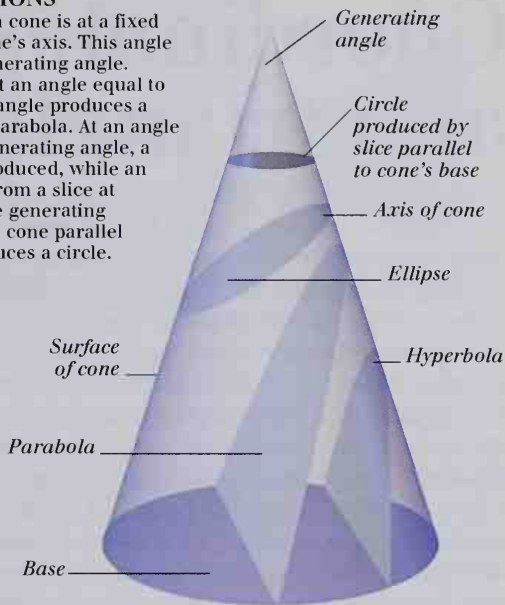

THE GEOMETRIES OF SPACE

Three-dimensional representation of four-dimensional space-time

Space-time is curved around an object with mass

Model of the Earth

Light rays follow the curvature of space-time

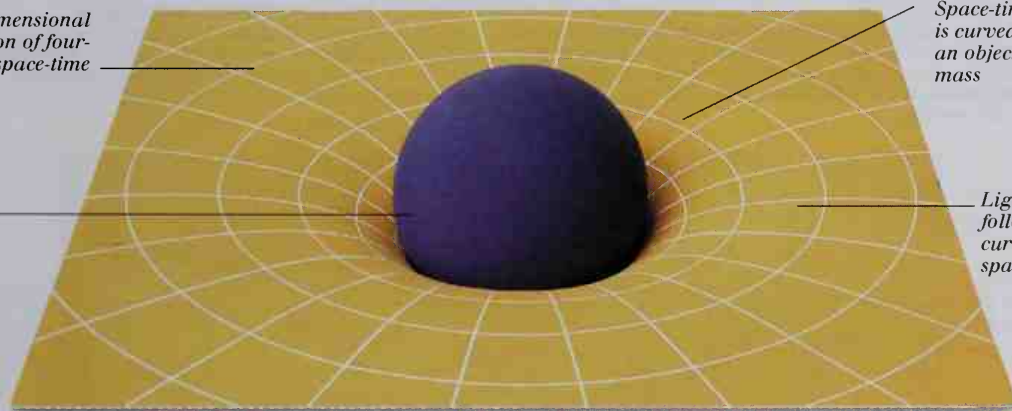

HYPERBOLIC GEOMETRY

Hyperbolic geometry applies to surfaces that have negative curvature. On such a surface, the internal angles of a triangle add up to less than 180°. Space is negatively-curved around a massive object such as the Sun.

The Earth is not perfectly spherical, but it still has a positively curved surface

ELLIPTIC GEOMETRY

Elliptic geometry applies to surfaces with positive curvature. The internal angles of a triangle on a positive surface add up to more than 180°. The surface of a sphere is an example of a surface with positive curvature.

Triangle formed by three right angles (each 90°)

Internal angles of triangle add up to 270°

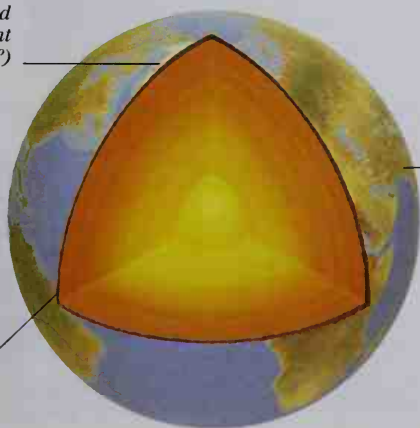

Coordinates and triangles

THE SIMPLEST COORDINATE SYSTEMS – called Cartesian coordinates – consist of lines (called axes) at right angles to each other. Lines with magnitude (size) and direction – called **vectors** – can represent various quantities, such as **velocity** or **force** (see pp. 20-21). The magnitude and direction of vectors are represented as lengths and angles in coordinate systems. It is useful to think of a vector as the longest side (the hypotenuse) of a right-angled triangle; an understanding of the properties of triangles is therefore useful when manipulating vectors. A simple rule called the Pythagorean theorem makes it possible to calculate the length of the hypotenuse of a right-angled triangle, armed only with the lengths of the other two sides of the triangle. The relationships between the sides and angles of right-angled triangles are studied in a branch of mathematics known as trigonometry.

CARTESIAN COORDINATES

The position of a point within a coordinate system can be defined using sets of numbers called coordinates. In a Cartesian system, coordinates are defined as lengths along axes, each of which is at right angles to all of the others. A two-dimensional Cartesian system has two axes, and so two coordinates are needed.

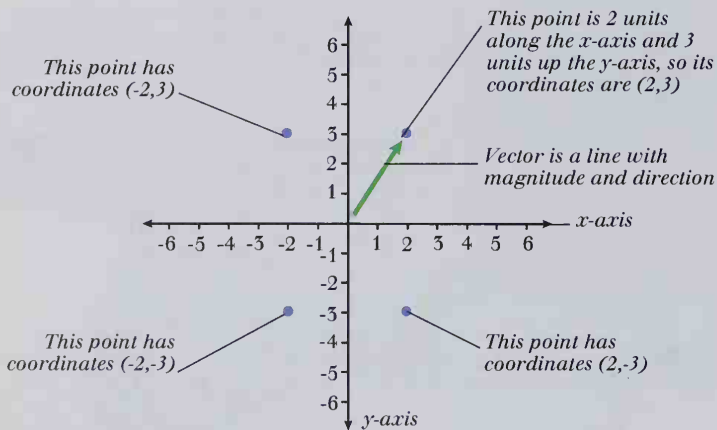

HEIGHT OF A TREE

The sides of any two similar triangles are always in proportion. The ratios of corresponding sides of two similar triangles are therefore always the same. Here, this property of similar triangles is used to figure out the height of a tree when standing at a known distance from it. One right-angled triangle has the height of the tree as one side, and the distance to the tree as another. When a similar triangle – all of whose sides are measurable – is compared with the larger triangle, the height of the tree can easily be figured out.

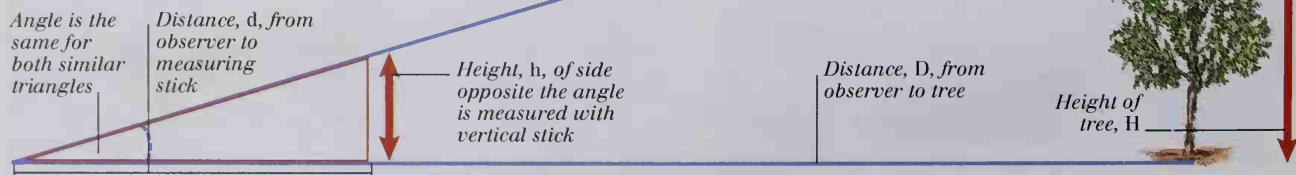

ANGLES

An angle is formed where two lines meet or cross and is expressed as the amount of rotation needed to move one of the lines to the position of the other, keeping the crossing point fixed. The size of an angle is normally measured in degrees (°). There are 360° in one complete turn.

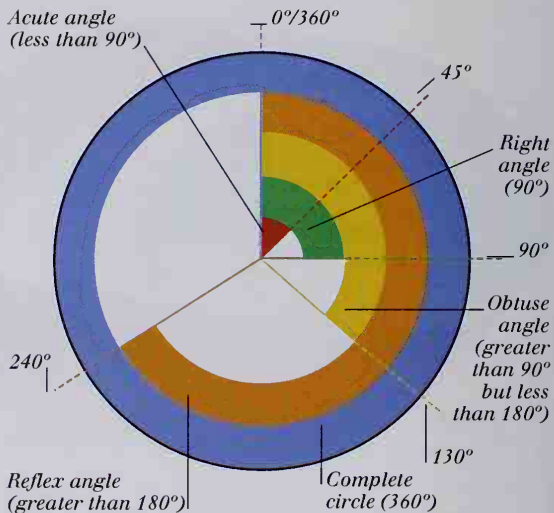

PYTHAGOREAN THEOREM

The square of the length of the longest side of a right-angled triangle (the hypotenuse, *C*, below) is equal to the sum of the squares of the other two sides ($C^2 = A^2 + B^2$).

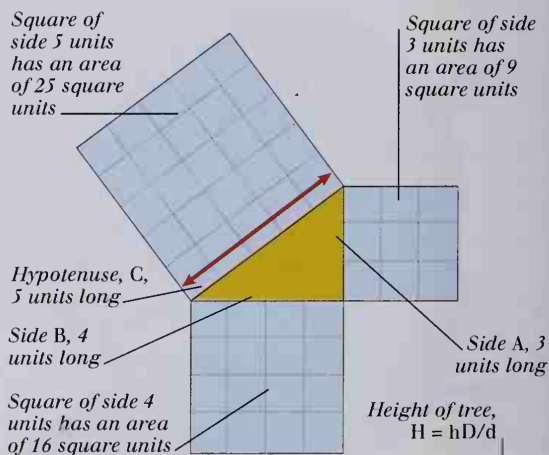

TRIGONOMETRIC FUNCTIONS FOR RIGHT ANGLED TRIANGLES

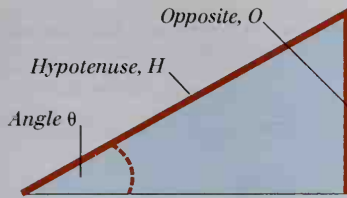

SINE (SIN) $\theta = O/H$

The sine of angle θ is the ratio of the length of the side opposite the angle to the length of the hypotenuse. A graph of the function $y = \sin x$ produces a repeating curve.

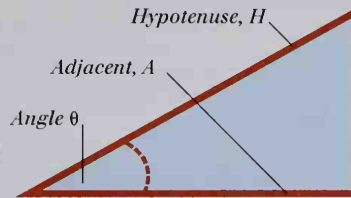

COSINE (COS) $\theta = A/H$

The cosine of angle θ is the ratio of the length of the side adjacent to the angle to the length of the hypotenuse. A graph of the function $y = \cos x$ also produces a repeating curve.

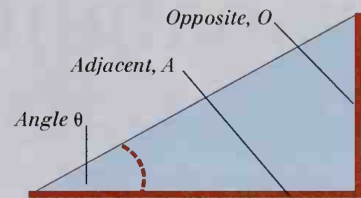

TANGENT (TAN) $\theta = O/A$

The tangent of angle θ is the ratio of the length of the side opposite the angle to the length of the side adjacent to the angle. The function $y = \tan x$ varies between $-\infty$ and $+\infty$.

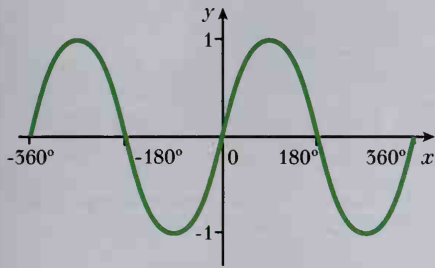

GRAPH OF THE FUNCTION $Y = \sin X$

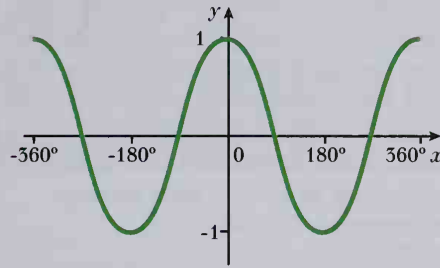

GRAPH OF THE FUNCTION $Y = \cos X$

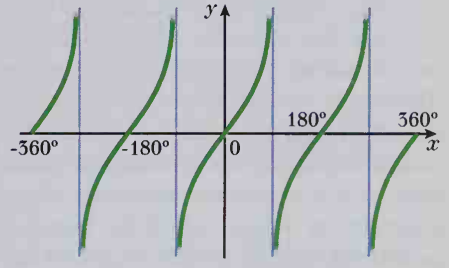

GRAPH OF THE FUNCTION $Y = \tan X$

VECTOR COORDINATES

In the map shown below, a vector represents the displacement of point B (at 5,4) from point A (at 1,1). Its magnitude can be worked out easily, using Pythagorean theorem. The direction of the vector can be solved by trigonometry, using the tangent function. The vector is at an angle

(measured from the horizontal) whose tangent is $\frac{3}{4}$, or 0.75. This is the tangent of an angle of about 37° . So, the vector has a compass bearing of 53° East (compass bearings are measured from North). Vectors have their own rules of addition. They are added head-to-tail, as shown.

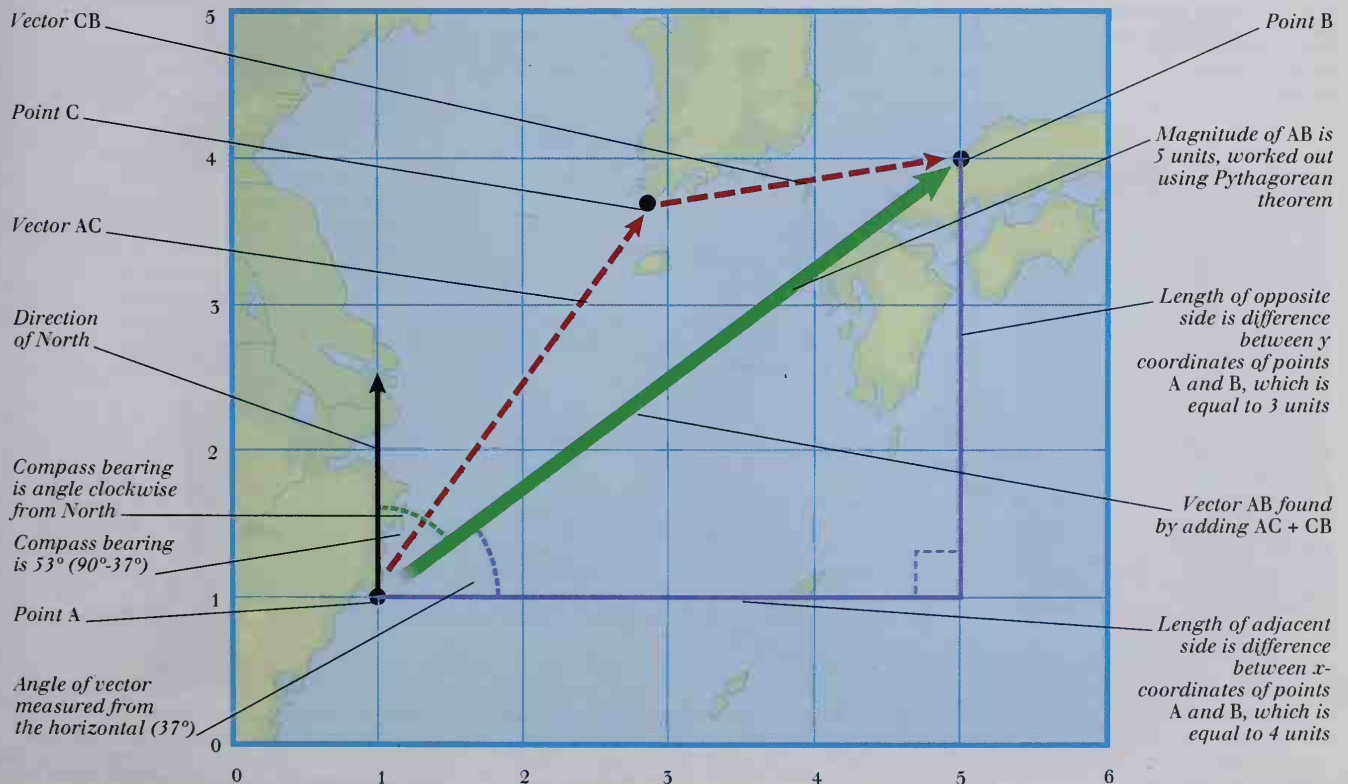

Probability and statistics

THE LIKELIHOOD THAT A CERTAIN EVENT will occur (its probability) is given as a number between zero (impossible) and one (certain). Some probabilities can be calculated quite easily – for example, those that govern the random selection from a collection of colored balls. Complex probabilities, such as the shapes of atomic orbitals (see pp. 160-161), however, may require the formulation of an algebraic function (see pp. 362-363). Probability theory is used in a branch of mathematics called statistics, which involves collecting and analyzing sets of data. Algebra is used in statistics in many ways, such as in calculating averages of a group of numbers or in finding trends in data. Statisticians use line graphs, bar charts, pie charts and scatter diagrams to visualize data. A line graph can highlight the distribution of a set of data around a particular value, called the mean. One common form of curve produced on line graphs is called the Gaussian distribution.

ATOMIC ORBITALS

The idea that an **electron** is not located at a definite distance from the **nucleus** is central to the modern understanding of the atom. Scientists think of electrons as existing in regions called orbitals, whose shapes can be calculated using probability theory. A distribution of probability is figured out as an algebraic function. As an illustration, one such function is plotted here over a diagram of an atomic orbital.

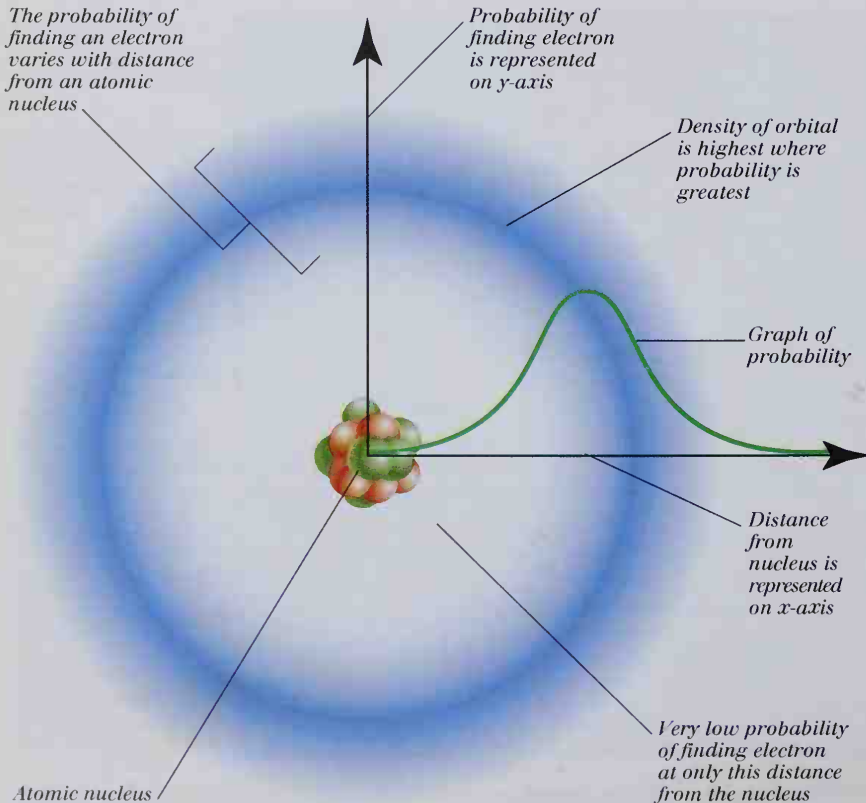

A LOT OF BALLS IN A BEAKER
The chance of selecting a ball of a particular color is equal to the number of balls that have that color divided by the total number of balls.

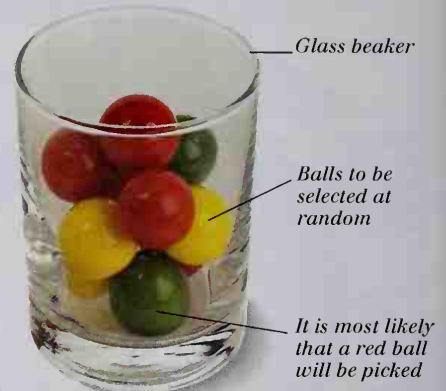

INITIAL PROBABILITIES
The beaker contains 5 red balls, 3 yellow balls, and 2 green balls. The probabilities of selecting these colors are 5/10, 3/10, and 2/10 respectively.

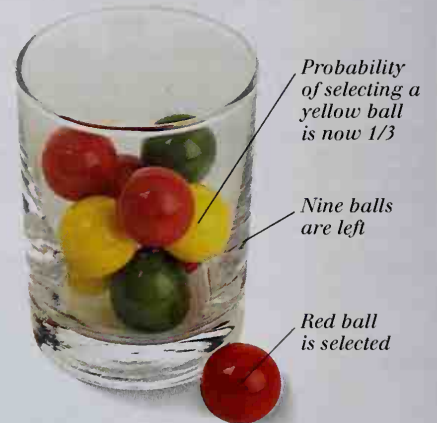

INDIVIDUAL EVENT
The probability of removing a red ball is initially 5/10. With one red ball removed, the probability of selecting another red ball is 4/9.



COMBINED EVENTS
The probability of selecting a red ball and then a yellow ball is equal to the probabilities of the two individual events multiplied together (5/10 × 1/3).

GRAPHS AND CHARTS

Probability and statistics are closely related. A bar chart and a pie chart are used here to visualize the probabilities of obtaining scores when throwing a pair of dice. Similar charts could have been obtained using so-called **empirical** data, collected by actually throwing a pair of dice a large number of times. A scatter diagram, which was produced from real empirical data, is also shown.

The chance of throwing a 5 and a 2 is $\frac{2}{36}$ ($\frac{1}{18}$)



DICE

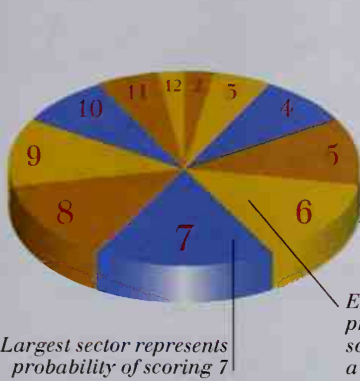
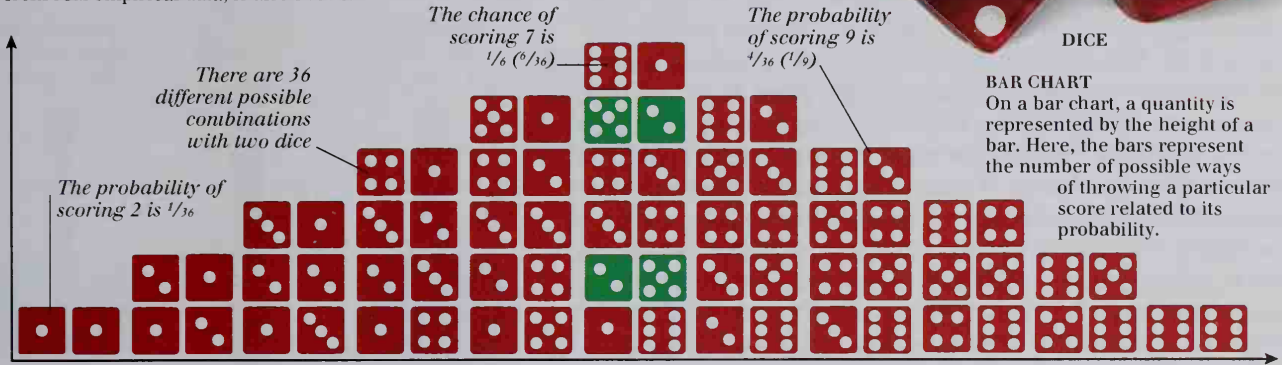

Frequency

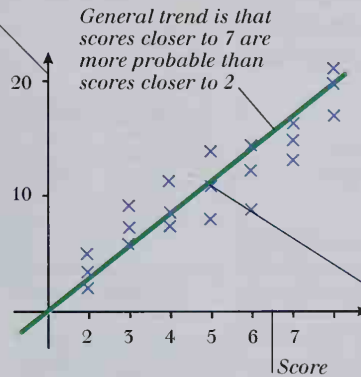

SCATTER DIAGRAM

A scatter graph can highlight trends, or correlations, in sets of data. Here, each cross represents the number of times a particular score was obtained (its frequency) when a pair of dice were thrown 100 times.

DISTRIBUTION CURVES

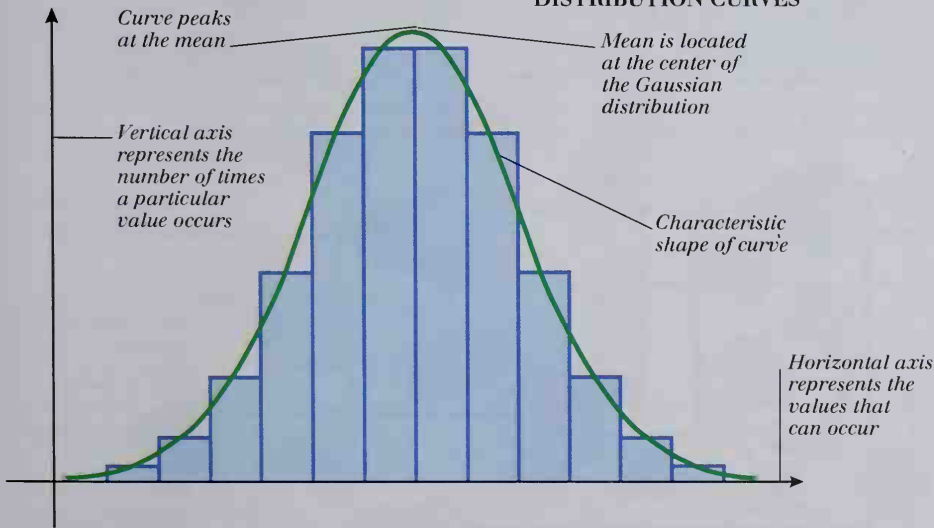

GAUSSIAN CURVE

Some sets of data can be plotted on a line graph, with the vertical axis representing the frequency of the values laid out on the horizontal axis. The shape of the curve shows the distribution of values of the data. The curve is often centered on a particular value, called the **mean**. Random variation around the mean of a distribution produces a Gaussian curve.

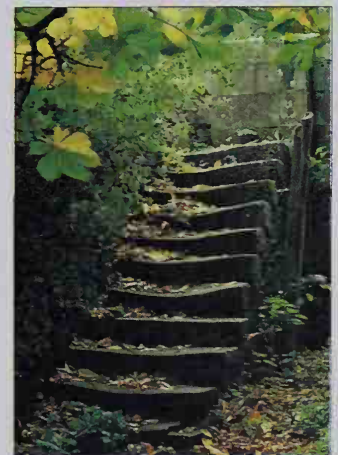

WELL-WORN STEPS

These ancient steps are a physical example of a Gaussian, or normal, distribution. The center of each step is more worn than the outer edges. This is because that is where the greatest number of people have walked.

Logic and sets

LOGIC IS USED TO DEDUCE whether mathematical ideas are correct or not. It is based on natural reasoning powers – such as those used when solving logic puzzles. Logic theory is used in the design of computers. A computer's central processing unit (see pp. 352-353) contains circuits called logic gates, which perform simple logical operations. Logic gates are combined to form circuits called adders, which perform **binary addition** (see pp. 360-361). Perhaps the most important part of logic theory is the formulation of logical arguments. These produce a statement (the conclusion) based on other statements (premises). The theory of logic is closely related to set theory – a set is a well-defined collection of items called elements. Using the rules of logic, set theory can help to solve simple or complex mathematical problems. Sets are often represented by circles, in pictures called Venn diagrams. These diagrams can help us visualize the relationships between sets, such as areas where sets have common elements (called intersections).

TOWER OF HANOI

This logic puzzle, called the Tower of Hanoi, consists of three rings and three pins. The rings must be moved from one pin to another, one-by-one, without ever placing a large ring on top of a small one. The least number of moves needed to complete the puzzle is given by the formula $2^n - 1$, where n is the number of rings present. So, with three rings, the puzzle can be completed in a minimum of seven moves ($2^3 - 1$).

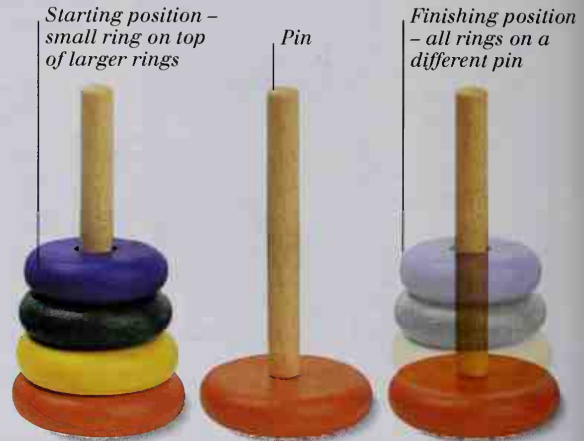

EXAMPLES OF LOGIC GATES

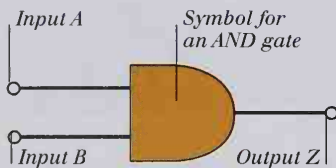

A	B	Z
0	0	0
0	1	0
1	0	0
1	1	1

AND GATE
A computer AND gate will output bit (binary digit) 1 only if both its inputs are 1s. This function, summarized in the truth table (left), is based on the logical operation AND.

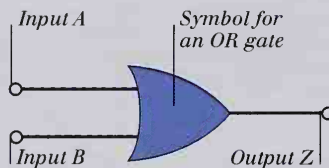

A	B	Z
0	0	0
0	1	1
1	0	1
1	1	1

OR GATE
A computer OR gate will output bit 1 if either or both its inputs are 1s. This function is based on the logical operation OR, and is summarized in the truth table (left).

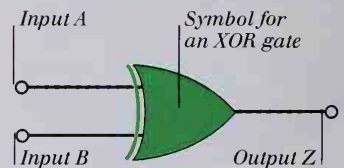

A	B	Z
0	0	0
0	1	1
1	0	1
1	1	0

XOR GATE
A computer's XOR (exclusive OR) gate will output bit 1 only if just one of its inputs is 1. If both of its inputs are 1, or if both of its inputs are 0, then it will output a 0.

FULL ADDER

However complex a computer may seem, the only arithmetic operation it can perform is addition. Subtraction is achieved by adding a negative number; multiplication is achieved by repeated addition; and division is achieved by repeated subtraction. Addition is carried out by logic gates, which are connected together to form circuits called adders. In binary, the sum of two bits (binary digits) can be only 0 (0 + 0), 1 (0 + 1 or 1 + 0) or 10 (1 + 1). In the last of these, the 1 of the sum must be carried over to the next part of the calculation. The inputs to the adder shown here are A, B, and C. The input at C is one bit carried over from the last part of a previous calculation.

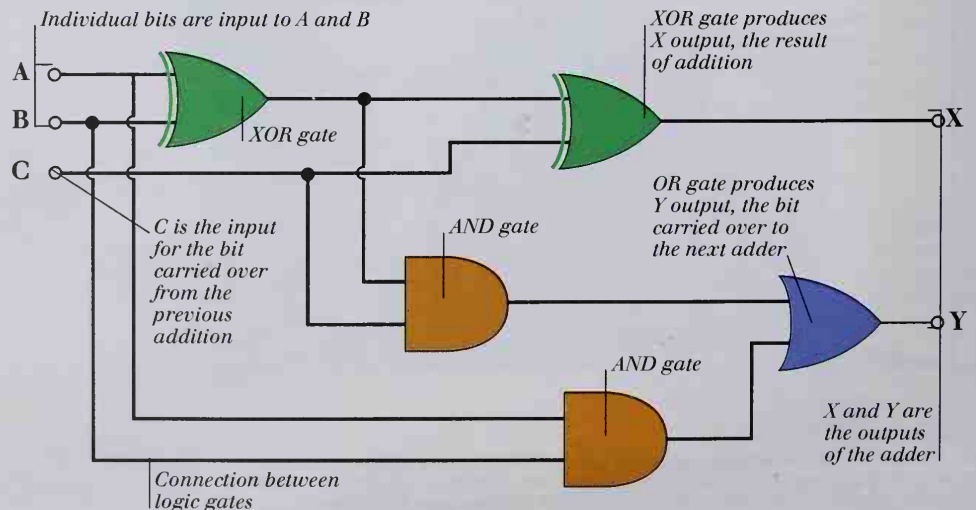

LOGICAL ARGUMENTS

Logic is based upon arguments that consist of two or more premises and a conclusion. Both premises and conclusions may be in the form of written statements, simple equations, or complex mathematical statements. The aim of the argument is to prove or disprove the truth of the conclusion. Simple arguments – of the kind shown here – are used

in most logical proofs. It is the structure of these proofs that is important – not the particular statements involved. So, although the arguments presented here may seem obvious, these simple structures can be very powerful when built into complicated mathematical proofs, sometimes providing new insights into complex mathematical problems.

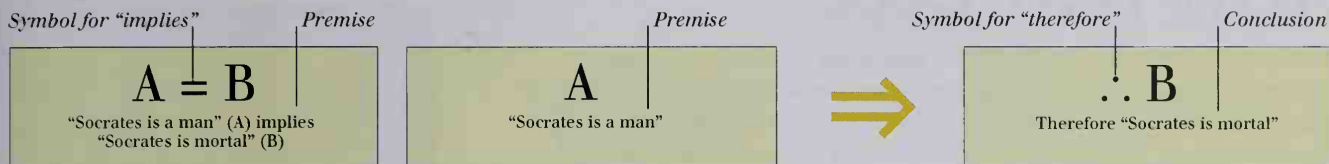

MODUS PONENS (METHOD OF AFFIRMING)

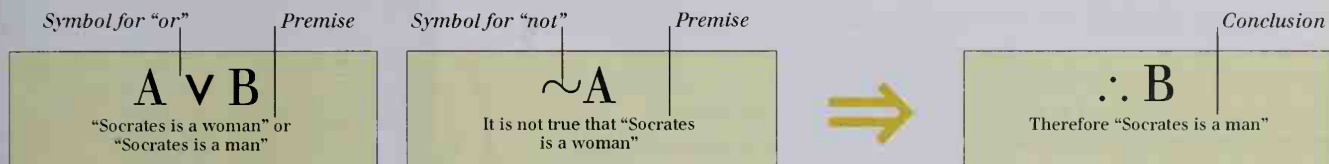

MODUS TOLLENDO PONENS (METHOD OF DENYING AND AFFIRMING)

SETS

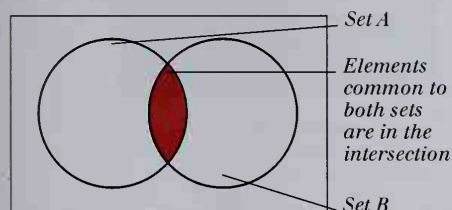

INTERSECTION
This is a Venn diagram. It shows the intersection of set A with set B. Intersection has the symbol \cap and is similar to the logic function AND, since an element in the intersection is in both sets.

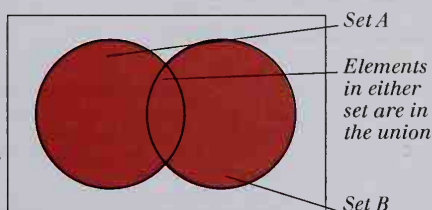

UNION
This Venn diagram shows the union of two sets. Union has the symbol \cup and is similar to the logic function OR, since elements in the union may be in either set A or set B.

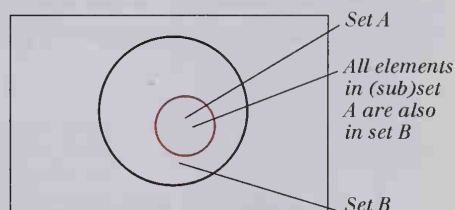

SUBSET
This Venn diagram shows one set as the subset of another – the elements in set A are all found in set B. The subset function has the symbol \subset .

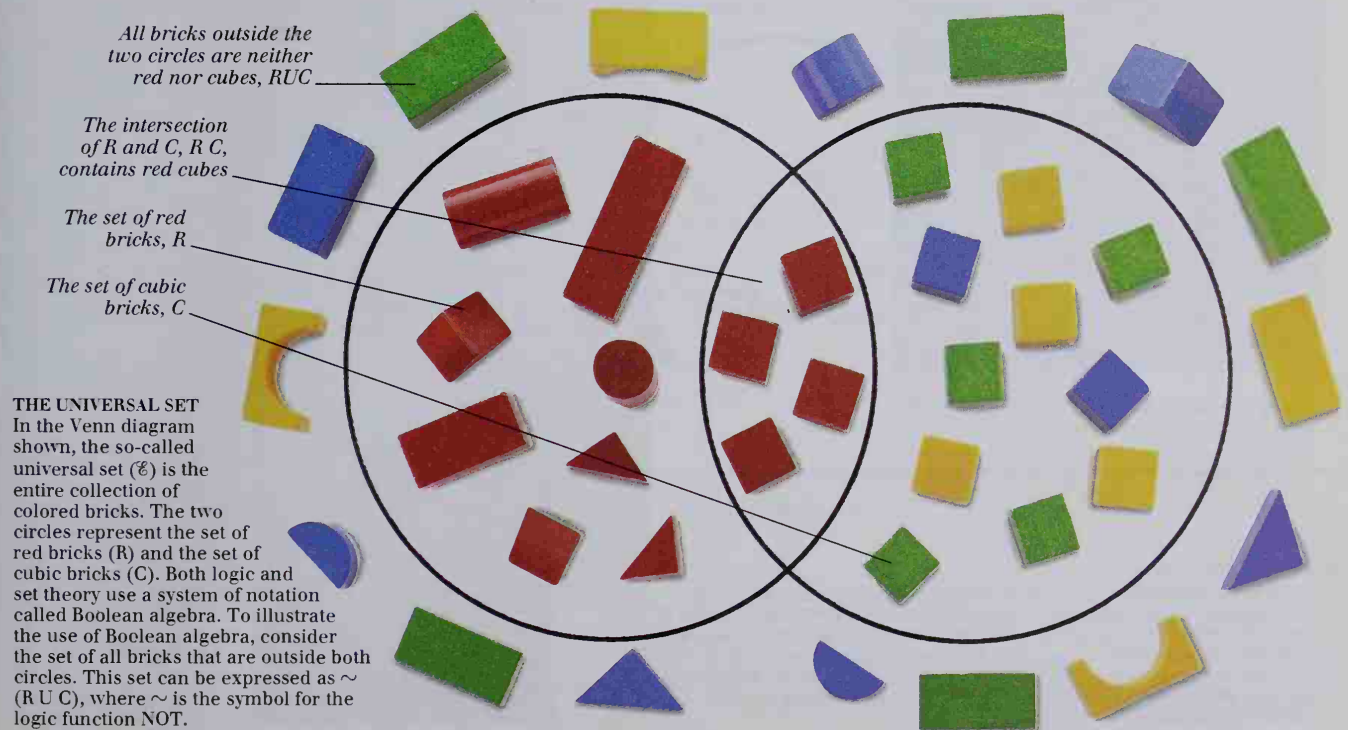

THE UNIVERSAL SET
In the Venn diagram shown, the so-called universal set (\mathcal{E}) is the entire collection of colored bricks. The two circles represent the set of red bricks (R) and the set of cubic bricks (C). Both logic and set theory use a system of notation called Boolean algebra. To illustrate the use of Boolean algebra, consider the set of all bricks that are outside both circles. This set can be expressed as $\sim(R \cup C)$, where \sim is the symbol for the logic function NOT.

Chaos theory and fractals

THE MOVEMENT OF RISING SMOKE particles is affected by many factors – including the immeasurable motions of millions of nearby air molecules – which is why it is described as a chaotic system. Chaos theory is an attempt to understand such systems. Mathematicians use graphs called simple or strange attractors to visualize the behavior of chaotic systems. Strange attractors are examples of fractals – geometrical figures that are closely related to chaos theory. Many fractals are seen in the natural world and are the result of underlying chaotic processes. These processes, which include growth and erosion, are iterated (repeated). Iteration gives rise to an important property of fractals, called self-similarity. A tiny portion of a fern frond, for example, looks similar to the entire fern. Like many natural fractals, computer-generated fractals are often stunningly beautiful.

TURBULENCE

Turbulence is easily seen in this photograph of smoke flowing upward from an extinguished candle. The lower part of the flow is smooth (laminar) and predictable. Higher up, however, there is a transition to turbulent (chaotic) flow.

Turbulence is typical of chaotic systems

Candlewick

Candle



The motion of smoke particles is impossible to predict, even though they follow simple physical laws

ATTRACTORS

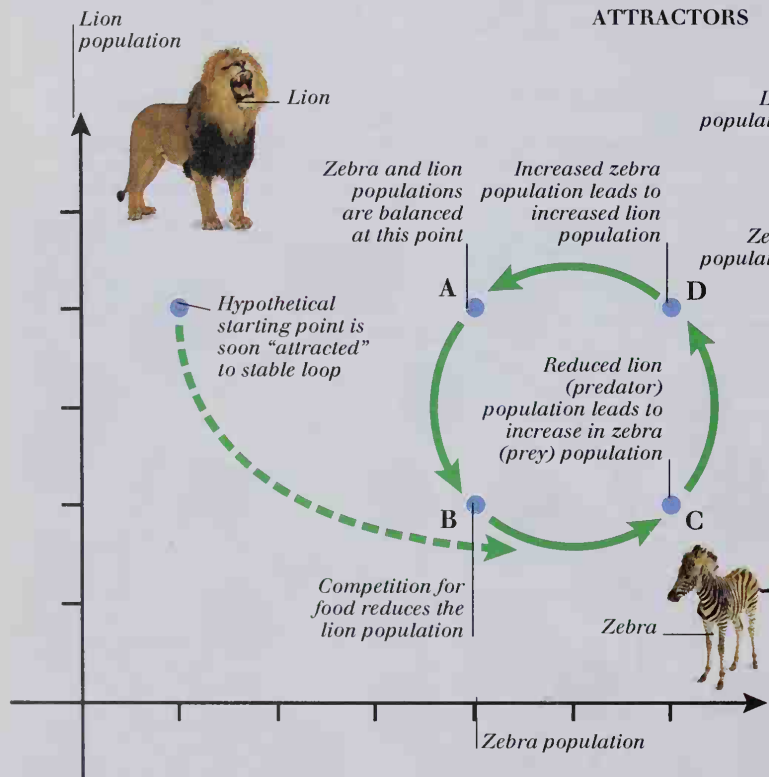

SIMPLE ATTRACTOR

The predator-prey model shown as a histogram (above right) can also be plotted as an attractor, to help visualize the system and formulate a model of its behavior. When the population values from the predator-prey histogram are plotted, a predictable, repeating cycle arises. It appears as a loop on the graph. This loop is called the attractor. Random factors, such as disease, may cause the predator-prey situation to become chaotic, in which case the graph would become a "strange attractor."

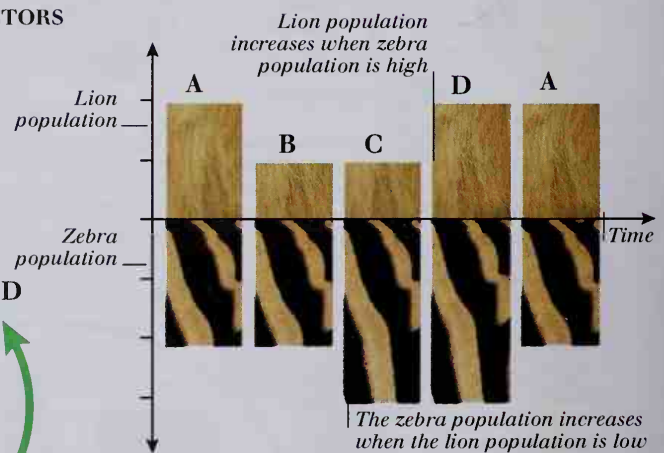

PREDATOR-PREY MODEL

The population of zebras in an enclosed area is partly dependent upon the population of lions, because lions prey on zebras. This predator-prey dependence is predictable (nonchaotic). It is illustrated here as a histogram.



Possible weather conditions lie along the attractor

STRANGE ATTRACTOR

All chaotic systems can be represented with a graph called a strange attractor. This one is associated with the intricate and unpredictable nature of weather patterns, and is called the Lorenz strange attractor after its creator, Edward Lorenz (1917-).

FRACTALS



Fern frond

Equilateral triangle

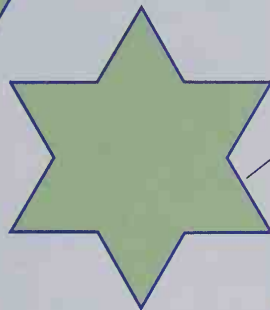

Each side of the triangle is divided into three, and an equilateral triangle is constructed on the middle third

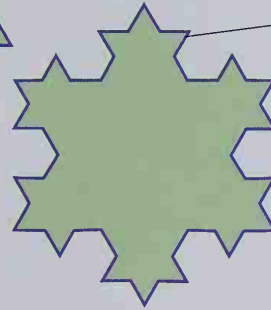

The process of constructing triangles is iterated, or repeated

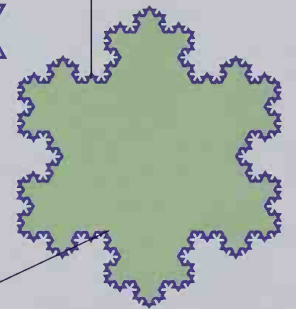

The triangles become progressively smaller

After an infinite number of iterations, the curve is an intricate and self-similar fractal

SELF-SIMILARITY

The most important feature of fractal geometry is self-similarity. One tiny part of this fern frond has been magnified to show that it has a similar form (shape) to the whole frond. This is due to the fact that growth occurs on a microscopic scale, and in this case the fractal form is observable at almost any magnification.

MANDELBROT-SET FRACTALS

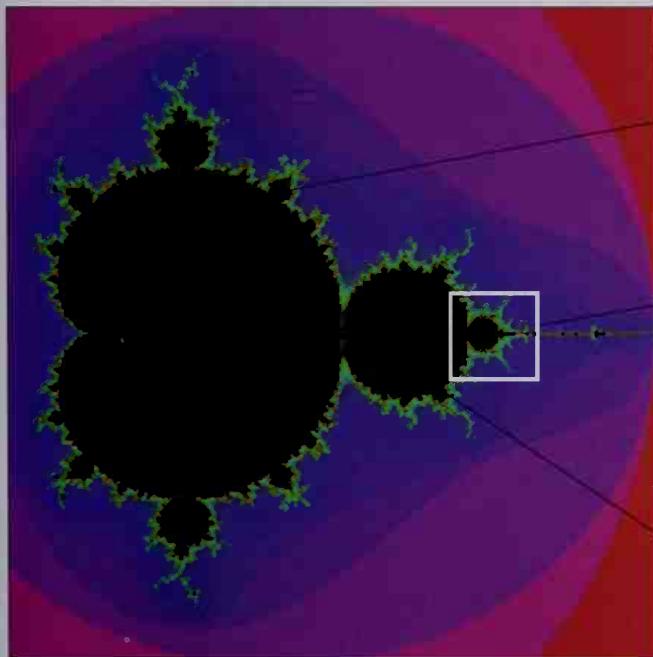

Fractal "edge"

Further magnification reveals more self-similarity

Small loop is similar to large loop

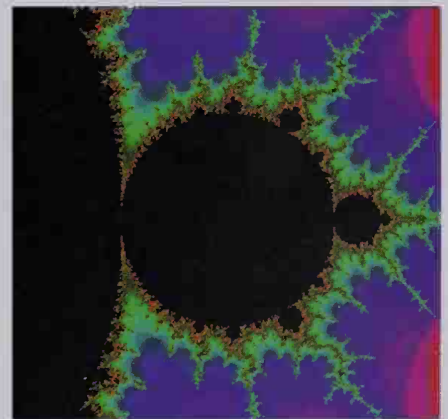

EXPLODED VIEW

Magnifying one small part of the Mandelbrot set reveals dramatic self-similarity. Parts of the Mandelbrot set are also reminiscent of natural forms that are created by chaotic processes, such as fractures in a sheet of ice.

$$z = z^2 + c$$

ITERATED EQUATION

The equation that is used to derive the Mandelbrot set is deceptively simple. Variables z and c are complex numbers.

MANDELBROT SET

The most famous fractal is the Mandelbrot set, named after Benoit Mandelbrot (1924-). It is a purely mathematical object, created by iterating a simple equation many times for each point in the square. Different colors represent different final values of the iterated equation, which is calculated using the power of modern computers.

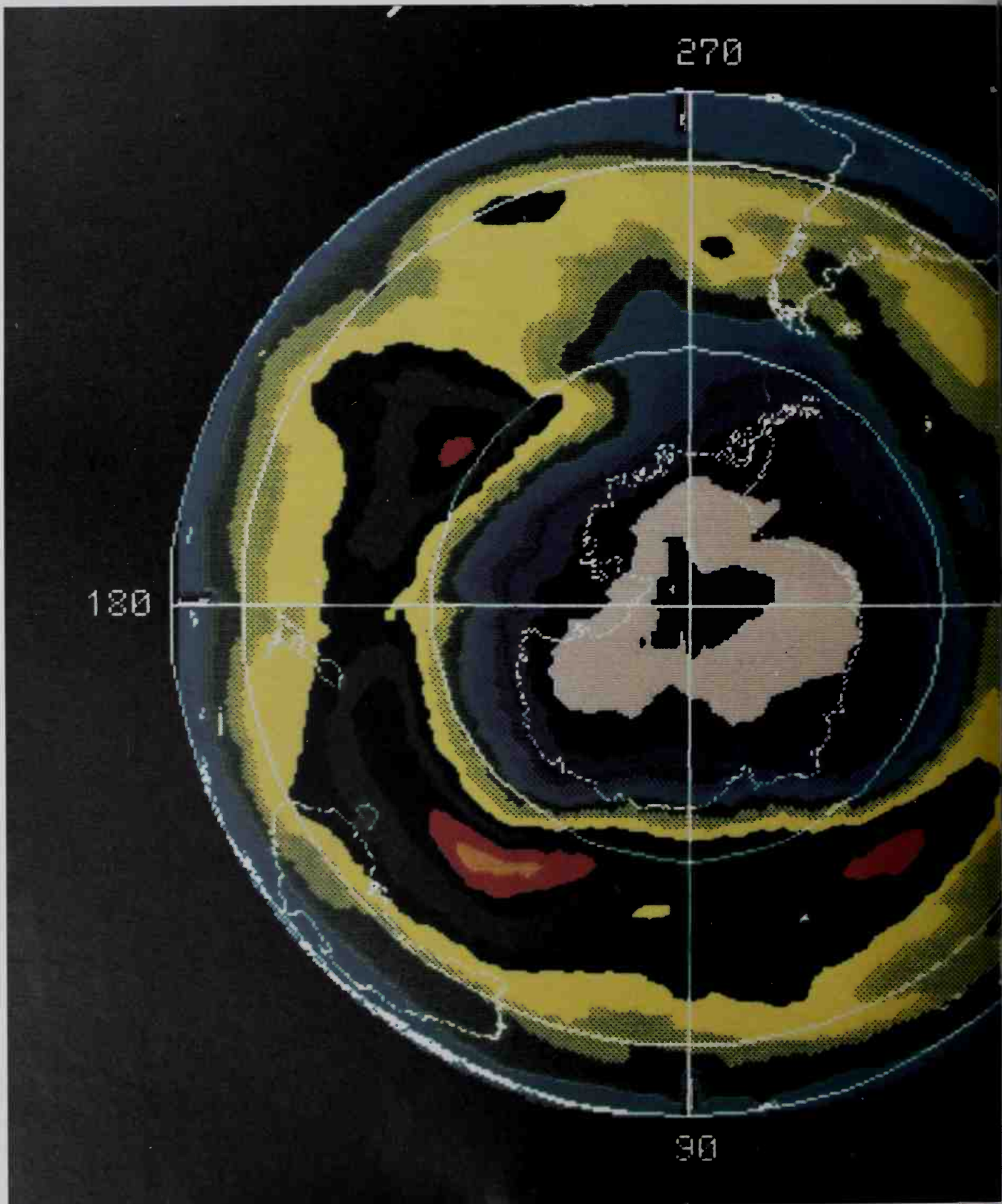

False-color satellite map of ozone levels over the South Pole

USEFUL DATA

WEIGHTS AND MEASURES	376
PHYSICS FORMULAS/CHEMISTRY DATA	378
LIFE SCIENCES AND MEDICAL SCIENCE DATA	380
EARTH SCIENCES DATA	382
ASTRONOMICAL DATA	384
STARS OF THE NORTHERN SKIES	386
STARS OF THE SOUTHERN SKIES	388
ELECTRONICS AND COMPUTING DATA	390
MATHEMATICS DATA	392

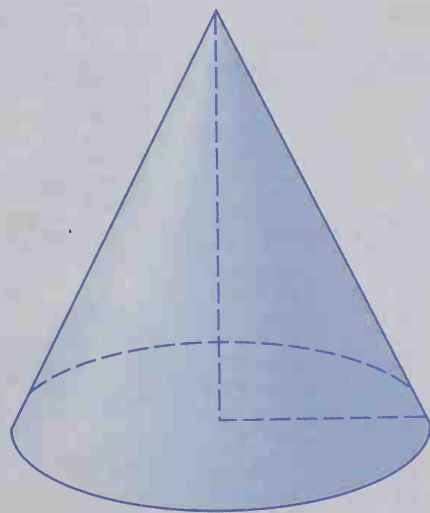

Weights and measures

UNITS OF MEASUREMENT

Imperial unit	Equivalent	Metric unit	Equivalent
Length		Length	
1 foot (ft)	12 inches (in)	1 centimeter (cm)	10 millimeters (mm)
1 yard (yd)	3 feet	1 meter (m)	100 centimeters
1 rod (rd)	5.5 yards	1 kilometer (km)	1,000 meters
1 mile (mi)	1,760 yards		
Mass		Mass	
1 dram (dr)	27.345 grains (gr)	1 kilogram (kg)	1,000 grams (g)
1 ounce (oz)	16 drams	1 metric ton (t)	1,000 kilograms
1 pound (lb)	16 ounces		
1 hundredweight (cwt) (short)	100 pounds		
1 hundredweight (cwt) (long)	112 pounds		
1 short ton (US)	2,000 pounds		
1 long ton (UK)	2,240 pounds		
Area		Area	
1 square foot (ft ²)	144 square inches (in ²)	1 square centimeter (cm ²)	100 square millimeters (mm ²)
1 square yard (yd ²)	9 square feet	1 square meter (m ²)	1,000 square centimeters
1 acre	4,840 square yards	1 hectare	10,000 square meters
1 square mile	640 acres	1 square kilometer (km ²)	1,000,000 square meters
Volume		Volume	
1 cubic foot	1,728 cubic inches	1 cubic centimeter (cc or cm ³)	1 milliliter (ml)
1 cubic yard	27 cubic feet	1 liter (l)	1,000 milliliters
		1 cubic meter (m ³)	1,000 liters
Capacity (liquid and dry measures)		Capacity (liquid and dry measures)	
1 fluidram (fl dr)	60 minims (min)	1 centiliter (cl)	10 milliliters (ml)
1 fluid ounce (fl oz)	8 fluidrams	1 deciliter (dl)	10 centiliters
1 gill (gi)	5 fluid ounces	1 liter (l)	10 deciliters
1 pint (pt)	4 gills	1 decaliter (dal)	10 liters
1 quart	2 pints	1 hectoliter (hl)	10 decaliters
1 gallon (gal)	4 quarts	1 kiloliter (kl)	10 hectoliters
1 peck (pk)	2 gallons		

NUMBER SYSTEMS

Roman	Arabic	Binary
I	1	1
II	2	10
III	3	11
IV	4	100
V	5	101
VI	6	110
VII	7	111
VIII	8	1000
IX	9	1001
X	10	1010
XI	11	1011
XII	12	1100
XIII	13	1101
XIV	14	1110
XX	20	10100
XXX	30	11110
XL	40	101000
L	50	110010
LX	60	111100
LXX	70	1000110
LXXX	80	1010000
XC	90	1011010
C	100	1100100
M	1,000	1111101000

TEMPERATURE SCALES

To convert	Into	Equation
Fahrenheit	Celsius	$C = (F - 32) \times 5 \div 9$
Celsius (C)	Fahrenheit (F)	$F = (C \times 9 \div 5) + 32$
Kelvin (K)	Fahrenheit	$F = ((K - 273) \times 9 \div 5) + 32$
Fahrenheit	Kelvin	$K = ((F - 32) \times 5 \div 9) + 273$
Celsius	Kelvin	$K = C + 273$

Scale	-4	14	32	50	68	86	104	122	140	158	176	194	212
Fahrenheit													
Celsius	-20	-10	0	10	20	30	40	50	60	70	80	90	100
Kelvin	253	263	273	283	293	303	313	323	333	343	353	363	373

IMPERIAL - METRIC CONVERSIONS

To convert	Into	Multiply by
Length		
Inches	centimeters	2.5400
Feet	meters	0.3048
Miles	kilometers	1.6090
Yards	meters	0.9144
Mass		
Ounces	grams	28.3500
Pounds	kilograms	0.4536
Short tons (US)	metric tons	0.9070
Area		
Square inches	square centimeters	6.452
Square feet	square meters	0.09290
Acres	hectare	0.4047
Square miles	square kilometer	2.590
Square yards	square meters	0.8361
Volume		
Cubic inches	cubic centimeters	16.3900
Cubic feet	cubic meters	0.02832
Cubic yards	cubic meters	0.7646
Capacity (liquid)		
Pints	liters	0.5683
Gallons	liters	4.546

POWERS OF TEN

Factor	Name	Prefix	Symbol
10 ¹⁸	quintillion	exa	E
10 ¹⁵	quadrillion	peta	P
10 ¹²	trillion	tera	T
10 ⁹	billion	giga-	G
10 ⁶	million	mega-	M
10 ³	thousand	kilo-	k
10 ²	hundred	hecto-	h
10 ¹	ten	deca-	da
10 ⁻¹	one tenth	deci-	d
10 ⁻²	one hundredth	centi-	c
10 ⁻³	one thousandth	milli-	m
10 ⁻⁶	one millionth	micro-	μ
10 ⁻⁹	one billionth	nano	n
10 ⁻¹²	one trillionth	pico-	p
10 ⁻¹⁵	one quadrillionth	femto-	f
10 ⁻¹⁸	one quintillionth	atto-	a

METRIC - IMPERIAL CONVERSIONS

To convert	Into	Multiply by
Length		
Centimeters	inches	0.3937
Meters	feet	3.2810
Kilometers	miles	0.6214
Meters	yards	1.0940
Mass		
Grams	ounces	0.03527
Kilograms	pounds	2.205
Metric tons	short tons (US)	1.1023
Area		
Square centimeters	square inches	0.1550
Square meters	square feet	10.7600
Hectares	acres	2.4710
Square kilometers	square miles	0.3861
Square meters	square yards	1.1960
Volume		
Cubic centimeters	cubic inches	0.06102
Cubic meters	cubic feet	35.31
Cubic meters	cubic yards	1.308
Capacity (liquid)		
Liters	pints	1.7600
Liters	gallons	0.2200

BASE SI UNITS

Physical quantity	SI unit	Symbol
Length	meter	m
Mass	kilogram	kg
Time	second	s
Electric current	ampere	A
Temperature	kelvin	K
Luminous intensity	candela	cd
Amount of substance	mole	mol
Plane angle	radian	rad
Solid angle	steradian	sr

DERIVED SI UNITS

Physical quantity	SI unit	Symbol
Frequency	hertz	Hz
Energy	joule	J
Force	newton	N
Power	watt	W
Pressure	pascal (newtons per square meter)	Pa (Nm ⁻²)
Electric charge	coulomb	C
Voltage	volt	V
Electric resistance	ohm	Ω

Physics formulas

PHYSICS SYMBOLS

Symbol	Meaning	Symbol	Meaning	Symbol	Meaning
α	alpha particle	η	efficiency; viscosity	ν	frequency; neutrino
β	beta particle	λ	wavelength	ρ	density; resistivity
γ	gamma ray; photon	μ	micro-; permeability	σ	conductivity
ϵ	electromotive force			c	speed of light

WEIGHT

Weight is equal to mass multiplied by acceleration due to gravity

$$W = mg$$

W = weight
m = mass
g = acceleration due to gravity

TURNING FORCE

Turning force is equal to force multiplied by distance of applied force from pivot

$$T = Fd$$

T = turning force (moment)
F = applied force
d = distance

PRESSURE

Pressure is equal to force applied divided by area over which force acts

$$P = F/A$$

P = pressure
F = applied force
A = area over which force acts

FORCE AND MOTION

NEWTON'S SECOND LAW

Acceleration is equal to force divided by mass

$$a = F/m$$

SPEED

Speed is equal to distance divided by time

$$v = d/t$$

CONSTANT ACCELERATION

Acceleration is equal to change in speed divided by time taken for that change

$$a = (v_2 - v_1)/t$$

MOMENTUM

Momentum is equal to mass multiplied by speed

$$p = mv$$

a = acceleration
m = mass
F = applied force
 v_1 = speed at the beginning of the time interval
 v_2 = speed at the end of the time interval
d = distance
t = time
p = momentum

GRAVITATION

Gravitational force equals a constant multiplied by mass one, multiplied by mass two, divided by the distance between the masses squared

$$F = Gm_1m_2/d^2$$

F = gravitational force between two objects
G = gravitational constant
 m_1 = mass of object one
 m_2 = mass of object two
d = distance between the two objects

FRICTION

Frictional force between two surfaces is equal to the coefficient of friction multiplied by the force acting to keep the surfaces together

$$F = \mu N$$

F = frictional force
 μ = coefficient of friction; this varies with materials
N = force between two surfaces

WORK

Work is equal to force multiplied by distance

$$W = Fd$$

W = work done
F = applied force
d = distance moved in line with force

CENTRIPETAL FORCE

Force is equal to mass multiplied by the speed squared divided by the radius

$$F = mv^2/r$$

F = centripetal force
m = mass of object
v = speed of circular motion
r = radius of object's path

LIQUID PRESSURE

Pressure is equal to the liquid's density multiplied by acceleration due to gravity multiplied by height of water above point

$$P = \rho gh$$

P = pressure
 ρ = liquid density
g = acceleration due to gravity
h = height of liquid above measured point

ELASTICITY

The extension of a solid is proportional to the force applied to it

$$F \propto x$$

F = applied force
x = extension of solid

GAS LAWS

BOYLE'S LAW

Volume is proportional to one divided by pressure

$$V \propto 1/P$$

CHARLES' LAW

Volume is proportional to temperature

$$V \propto T$$

PRESSURE LAW

Pressure is proportional to temperature

$$P \propto T$$

THE IDEAL-GAS EQUATION

Pressure multiplied by volume is equal to ideal-gas constant multiplied by temperature

$$PV = RT \text{ (for one mole of gas)}$$

V = volume
P = pressure
T = temperature
R = ideal-gas constant

ELECTRIC CIRCUITS

CURRENT, VOLTAGE, AND RESISTANCE

Current is equal to voltage divided by resistance

$$I = V/R$$

POWER

Power is equal to voltage multiplied by current

$$P = VI$$

I = current
V = voltage
R = resistance
P = power

IMAGE FORMATION

One divided by the focal length is equal to one divided by the object's distance from lens added to one divided by distance from the lens to the image

$$1/f = 1/u + 1/v$$

f = focal length
u = object's distance from lens
v = distance from lens to image

Chemistry data

IONS AND RADICALS

Name	Formula and charge
Hydrogen	H ⁺
Sodium	Na ⁺
Potassium	K ⁺
Magnesium	Mg ²⁺
Calcium	Ca ²⁺
Aluminum	Al ³⁺
Iron (II)	Fe ²⁺
Iron (III)	Fe ³⁺
Copper (I)	Cu ⁺
Copper (II)	Cu ²⁺
Silver (I)	Ag ⁺
Zinc	Zn ²⁺
Ammonium	NH ⁴⁺
Hydronium	H ₃ O ⁺
Oxide	O ²⁻
Sulfide	S ²⁻
Fluoride	F ⁻
Chloride	Cl ⁻
Bromide	Br ⁻
Iodide	I ⁻
Hydroxide	OH ⁻
Carbonate	CO ₃ ²⁻
Hydrogen Carbonate	HCO ₃ ⁻
Nitrate (V)	NO ₃ ⁻
Sulfate (VI)	SO ₄ ²⁻

COMMON NAMES AND FORMULAS OF IMPORTANT COMPOUNDS

Common name	Chemical name	Formula
Water	Hydrogen oxide	H ₂ O
Salt	Sodium chloride	NaCl
Baking soda	Sodium bicarbonate	NaHCO ₃
Washing soda	Sodium carbonate decahydrate	Na ₂ CO ₃ ·10H ₂ O
Household bleach	Sodium chlorate (I)	NaOCl
Rubbing alcohol	Methanol	CH ₃ OH
Alcohol	Ethanol	C ₂ H ₅ OH
Vinegar	Ethanoic acid	CH ₃ COOH
Vitamin C	Ascorbic acid	C ₆ H ₈ O ₆ ·CHOH·CH ₂ OH
Aspirin	Acetylsalicylic acid	C ₉ H ₈ O ₄ ·COOCH ₃ ·COOH
White sugar	Sucrose	C ₆ H ₁₁ O ₅ ·O·C ₆ H ₁₁ O ₅
Limestone/chalk	Calcium carbonate	CaCO ₃
Plaster of Paris	Calcium sulfate hemihydrate	CaSO ₄ ·½H ₂ O
Rust	Hydrated iron (III) oxide	Fe ₂ O ₃ ·xH ₂ O

NAMES AND STRUCTURES OF COMMON PLASTICS

Common name of plastic	Proper name	Repeated unit (monomer)
Polythene	Poly(ethene)	Ethene, C ₂ H ₄
PVC or polyvinylchloride	Poly(chloroethene)	Chloroethene, C ₂ H ₃ Cl
Polystyrene	Poly(phenylethene)	Phenylethene, C ₆ H ₅ ·C ₆ H ₄
Acrylic	Poly(propenonitrile)	Propenonitrile, C ₃ H ₃ ·CH ₂ ·CN
PTFE or Teflon®	Poly(tetrafluoroethene)	Tetrafluoroethene, C ₂ F ₄

DISCOVERY OF ELEMENTS

Element name	Discovered*	Origin of name
Carbon, C	Known since ancient times	Latin <i>carbo</i> , charcoal
Gold, Au	Known since ancient times	Old English <i>geolo</i> , yellow; Latin <i>aurum</i> , gold
Sulfur, S	Known since ancient times	Latin <i>sulfur</i> , brimstone
Platinum, Pt	16th century	Spanish <i>platina</i> , little silver
Cobalt, Co	1755 by Georg Brandt	German <i>kobold</i> , goblin
Hydrogen, H	1766 by Henry Cavendish	Greek <i>hydro-</i> and <i>genes</i> , water-maker
Chlorine, Cl	1774 by Karl Wilhelm Scheele	Greek <i>chloros</i> , greenish-yellow
Tungsten, W	1783 by Juan José and Fausto Elhuyar	Swedish <i>tung</i> , heavy, and <i>sten</i> , stone; German <i>wolfram</i>
Chromium, Cr	1797 by Nicolas-Louis Vauquelin	Greek <i>chroma</i> , color
Bromine, Br	1826 by Antoine-Jérôme Balard	Greek <i>bromos</i> , stench
Helium, He	1868 by Pierre Janssen and Norman Lockyer	Greek <i>helios</i> , the Sun
Unnilquadium, Unq	1964 (in USSR) and 1969 (in US)	Latin for 104, the element's atomic number

* Generally refers to when the pure substance was first isolated – its recognition as an element often came later.

** Because of disputes over the discovery of elements with atomic numbers 104–109, their names are yet to be finalized.

MELTING AND BOILING POINTS OF ELEMENTS

Element	Melting point		Boiling point	
	°C	°F	°C	°F
Mercury	-59	-58	357	675
Helium	-272	-458	-269	-452
Tungsten	3,410	6,170	5,555	10,051
Nitrogen	-210	-346	-196	-321
Sodium	98	208	883	1,621
Oxygen	-219	-362	-183	-297
Bromine	-7	19	59	158
Iron	1,535	2,795	2,862	5,184
Carbon	3,550	6,420	4,827	8,720
Gold	1,063	1,945	2,970	5,379

ELEMENTS IN THE EARTH'S CRUST

Element	Mass (%)
Oxygen	49.13
Silicon	26.00
Aluminum	7.45
Iron	4.20
Calcium	3.25
Sodium	2.40
Potassium	2.35
Magnesium	2.35
Hydrogen	1.00
Others	1.87

Life sciences data

ANIMAL ENERGY REQUIREMENT

Animal	Scientific name	kJ required per day for moderate amount of activity
House mouse	<i>Mus musculus</i>	45.4
European robin	<i>Erithacus rubecula</i>	89.9
Peregrine falcon	<i>Falco peregrinus</i>	277
Gray squirrel	<i>Sciurus carolinensis</i>	386
Fennec fox	<i>Vulpes zerda</i>	1,067
Domestic cat	<i>Felis catus</i>	1,554
Baboon	<i>Papio hamadryas</i>	6,762
Giant anteater	<i>Myrmecophaga tridactyla</i>	7,392
Female human being	<i>Homo sapiens</i>	10,080
Male human being	<i>Homo sapiens</i>	13,715
Llama	<i>Lama glama</i>	16,128
Tiger	<i>Panthera tigris</i>	33,600
Gorilla	<i>Gorilla gorilla</i>	34,020
American black bear	<i>Ursus americanus</i>	38,556
Giraffe	<i>Giraffa camelopardalis</i>	152,754
Walrus	<i>Odobnus rosmarus</i>	159,852
Male Indian elephant	<i>Elephas maximus</i>	256,872

ANIMAL SPEED OF MOVEMENT

Animal	Scientific name	Top speed
Spine-tailed swift	<i>Chaetura caudacuta</i>	177
Mallard	<i>Anas platyrhynchos</i>	108
English hare	<i>Lepus timidus</i>	75
Racehorse, mounted	<i>Equus caballus</i>	75
Dragonfly	<i>Austrophlebia</i>	60
Human being	<i>Homo sapiens</i>	48
Fox	<i>Vulpes fulva</i>	47
Salmon	<i>Salmo salar</i>	38
Wasp	<i>Vespa vulgaris</i>	20
Adelie penguin*	<i>Pygoscelis adeliae</i>	14
Spider	<i>Tegenaria atrica</i>	2
Centipede	<i>Scutigera coleoptera</i>	1.8
Giant tortoise	<i>Geochelone gigantea</i>	0.28
Garden snail	<i>Helix aspersa</i>	0.03

* = underwater

ANIMAL LONGEVITY

Animal	Scientific name	Approximate maximum life span
Marion's tortoise	<i>Testudo sumerii</i>	152 years
Human being	<i>Homo sapiens</i>	115 years
Blue whale	<i>Balaenoptera musculus</i>	90 years
Indian elephant	<i>Elephas maximus</i>	70 years
Hippopotamus	<i>Hippopotamus amphibius</i>	54 years
Common boa	<i>Boa constrictor</i>	40 years
Giant clam	<i>Tridacna gigas</i>	30 years
Sheep	<i>Ovis aries</i>	22 years
Guinea pig	<i>Cavia porcellus</i>	13 years
House mouse	<i>Mus musculus</i>	6 years
Bedbug	<i>Cimex lectularius</i>	0.5 years
Housefly	<i>Musca domestica</i>	0.2 years

ANIMAL KINGDOM PIE CHART

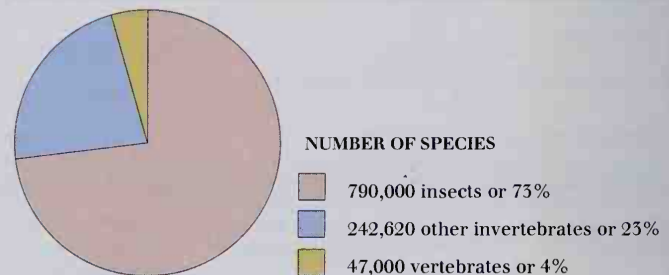

ANIMAL HOMES

Animal	Description of home	Name of home
Squirrel	Nest of twigs	Drey
Badger	Underground chambers	Sett
Eagle	Nest of twigs	Eyrie
Rabbit	Burrow	Warren
River otter	Burrow in riverbank	Holt

ECOLOGY: PRIMARY PRODUCTION

Habitat	Primary production (grams of dry plant material per sq meter per year)
Coral reef	2,500
Tropical rainforest	2,200
Temperate rainforest	1,250
Savannah	900
Cultivated land	650
Open sea	125
Semidesert	90

GESTATION PERIODS

Animal	Scientific name	Gestation period (days)	Number of young
Virginia opossum	<i>Didelphis virginiana</i>	12	8-14
Golden hamster	<i>Mesocricetus auratus</i>	15	6-8
House mouse	<i>Mus musculus</i>	20	6-8
Red kangaroo	<i>Macropus rufus</i>	33	1
Lion	<i>Panthera leo</i>	105-108	3-4
Domestic goat	<i>Capra hircus</i>	150	1-2
Orangutan	<i>Pongo pygmaeus</i>	250	1
Human being	<i>Homo sapiens</i>	267	1
Wild cattle	<i>Bovidae artiodactyla</i>	278	1
Bottle-nosed dolphin	<i>Tursiops truncatus</i>	360	1
Indian elephant	<i>Elephas maximus</i>	660	1

Medical science data

VITAMINS TABLE

Name	Where found	Required for
Vitamin A	Liver, fish, oils, egg yolk, yellow-orange fruit and vegetables	Growth, healthy eyes and skin, fighting infection
Vitamin B1 (thiamine)	Whole grains (wholemeal bread and pasta) brown rice, liver, beans, peas, and eggs	Healthy functioning of nervous and digestive systems
Vitamin B2 (riboflavin)	Milk, liver, cheese, eggs, green vegetables, brewer's yeast, whole grains, and wheat germ	Metabolism of protein, fat, and carbohydrates; keeping tissue healthy
Vitamin B5 (niacin)	Liver, lean meats, poultry, fish, and dried beans and nuts	Production of energy and a healthy skin
Vitamin B6 (pyridoxine)	Liver, poultry, pork, fish, bananas, potatoes, dried beans, and most fruit and vegetables	Metabolism of protein and production of red blood cells
Vitamin C	Citrus fruit, strawberries, and potatoes	Healthy skin, teeth, bones, and tissues; for fighting disease
Vitamin D	Oily fish (such as salmon), liver, cod-liver oil, eggs, and cereals	The absorption of calcium and phosphates
Vitamin E	Margarine, whole-grain cereals, and nuts	The formation of new red blood cells; protection of cell linings in the lungs

BRANCHES OF MEDICINE

Name	Concerns
Cardiology	Heart and arteries
Chiroprody	Feet
Dermatology	Skin
Endocrinology	Hormones
Gastroenterology	Stomach, intestines
Geriatrics	Elderly people
Gynecology	Female reproductive organs
Hematology	Blood
Nephrology	Kidneys
Neurology	Brain and nerves
Ophthalmology	Eyes
Osteopathy	Manipulation of back and limbs to ease pain
Pediatrics	Children
Pharmacology	Drugs
Physiotherapy	Manipulation and massage of body to ease pain
Psychiatry	Mental illness
Obstetrics	Pregnancy and childbirth
Oncology	Growths and tumors (cancers)
Orthopedics	Bones, joints, and muscles
Pathology	Body tissues and fluids
Radiology	X rays
Radiotherapy	Use of radiation to kill unwanted cells

COMMON MEDICAL COMPLAINTS

Complaint	Description
Alzheimer's disease	Deterioration of speech, memory, and general mental faculties, due to death of brain cells
Anemia	Deficiency of hemoglobin in red blood cells
Aneurysm	Thinning and dilation of walls of artery
Angina	Tight chest pain caused by lack of oxygen, often because of narrowed arteries
Asthma	Disease of the respiratory system that causes wheezing and difficult breathing
Bronchitis	Inflammation of the bronchi
Cavities	Patches of decay and erosion of tooth enamel, and dentine by plaque
Cataracts	Cloudiness of the lens of the eye. Causes nearsightedness or blindness
Conjunctivitis	Inflammation of the conjunctiva, causing eye redness and discomfort
Eczema	Itchy skin infection, often causing blisters and scaling
Endocarditis	Infection of the heart tissue
Glaucoma	High pressure in the eye's fluid, causing pain and partial or total loss of vision
Hayfever (allergic rhinitis)	Inflammation of mucus membrane caused by allergy to pollen
Hepatitis	Inflammation of the liver caused by viral infection
Laryngitis	Inflammation of the larynx due to infection, leading to loss of voice
Meningitis	Inflammation of the meninges (outer layers of brain), bacterial and viral forms
Multiple sclerosis (MS)	Progressive disease of the central nervous system that destroys the outer coating of nerves
Muscular dystrophy	Progressive wasting of muscle fibers (an inherited illness)
Osteoporosis	Thinning and weakening of bone with age
Pneumonia	Inflammation of the lungs caused by infection
Psoriasis	Skin disorder causing red skin covered with silvery scales
Tetanus	Continuous contraction of muscle
Varicose vein	Swelling and twisting of a vein

DRUG TYPES

Name	Use
Analgesic	Provides relief from pain such as headache and stomachache
Antacid	Counteracts acid in the stomach to relieve heartburn, indigestion, etc.
Antibiotic	Treats infection by killing bacteria in the body
Antihistamine	Counteracts allergies such as hayfever
Antipyretic	Reduces fevers such as influenza
Bronchodilator	Eases breathing in diseases such as asthma
Decongestant	Common cold treatment; works by unblocking nasal passages

Earth sciences data

EARTH PROFILE

Feature	
Average distance from Sun (km)	149,600,000
Maximum distance from Sun (km)	152,100,000
Minimum distance from Sun (km)	147,100,000
Length of year (days)	365.26
Length of day (hours)	23.95
Surface temperature range (° C)	-88.3 to 58.0
Mass (billion billion metric tons)	5,976
Volume (km ³)	1,083,230,000,000
Axial tilt (degrees)	23.5
Specific gravity (water = 1)	5.52
Polar diameter (km)	12,714
Equatorial diameter (km)	12,756
Polar circumference (km)	40,008
Equatorial circumference (km)	40,075
Total surface area (km ²)	510,000,000
Land as % of total surface area	29.2
Water as % of total surface area	70.8
Highest point on land (m)	8,848
Lowest point on land (m below sea level)	2,538
Average height of land (m)	840
Greatest ocean depth (m)	10,924
Average ocean depth (m)	3,808
Oceanic crust thickness (km)	6
Continental crust thickness (km)	40
Mantle thickness (km)	2,800
Outer core thickness (km)	2,300
Inner core diameter (km)	2,400
Approximate age of Earth (millions of years)	4,600

DEEPEST TRENCHES

Name	Length (km)	Deepest point	Depth (m)
Mariana Trench (W. Pacific)	2,250	Challenger Deep	10,924
Tonga-Kermadec Trench (S. Pacific)	2,575	Vityaz II (Tonga)	10,800
Kuril-Kamchatka Trench (W. Pacific)	2,250	Unnamed	10,542
Philippine Trench (W. Pacific)	1,325	Galathea Deep	10,539
Soloman/New Britain Trench (S. Pacific)	640	Unnamed	8,940
Puerto Rico Trench (W. Atlantic)	800	Milwaukee Deep	8,605
Yap Trench (W. Pacific)	560	Unnamed	8,527
Japan Trench (W. Pacific)	1,600	Unnamed	8,412
South Sandwich Trench (S. Atlantic)	965	Meteor Deep	8,325

CONTINENTS

Name	Area (km ²)	% of total surface area	% of total land area	Highest point	Height (m)	Lowest point	Below sea level (m)
Asia	44,000,000	8.6	29.5	Mt. Everest	8,848	Dead Sea	400
Africa	30,000,000	5.9	20.1	Kilimanjaro	5,895	Lac Assal	156
N. America	24,000,000	4.7	16.1	Denali (Mt. McKinley)	6,194	Death Valley	86
S. America	18,000,000	3.5	12.1	Aconcagua	6,960	Peninsular Valdez	40
Antarctica	14,000,000	2.7	9.4	Vinson Massif	5,140	Bentley Trench	2,538
Europe	10,000,000	2.0	6.7	El'brus	5,642	Caspian Sea	28
Australasia	9,000,000	1.8	6.1	Mt. Wilhelm	4,884	Lake Eyre	16

WEATHER

Record	Reading	Place	Date
Highest-recorded temperature	58° C	Al' Aziziyah, Libya	September 13, 1922
Lowest-recorded temperature	-88.38° C	Vostok, Antarctica	August 24, 1960
Greatest average yearly rainfall	11,455 mm	Mt. Wai'ale'ale, Hawaii	
Greatest-recorded rainfall in any one year	26,461 mm	Cherrapunji, India	1860-61
Windiest place	320 km/h winds	Commonwealth Bay, Antarctica	
Highest-recorded windspeed	371 km/h	Mt. Washington, New Hampshire	1934

LARGEST OCEANS AND SEAS

Name	Area (km ²)	Average depth (m)
Pacific Ocean	166,229,000	4,028
Atlantic Ocean	86,551,000	3,926
Indian Ocean	73,422,000	3,963
Arctic Ocean	13,223,000	1,205
South China Sea	2,975,000	1,652
Caribbean Sea	2,516,000	2,467
Mediterranean Sea	2,509,000	1,429
Bering Sea	2,261,000	1,547
Gulf of Mexico	1,508,000	1,486
Sea of Okhotsk	1,592,000	840
Sea of Japan	1,013,000	1,370
Hudson Bay	730,000	120
East China Sea	665,000	180
Black Sea	508,000	1,100
Red Sea	453,000	490

LARGEST ISLANDS

Name	Area (km ²)
Greenland	2,175,219
New Guinea	792,493
Borneo	725,416
Madagascar	587,009
Baffin Island (Canada)	507,423
Sumatra	427,325
Honshu (Japan)	227,401
Great Britain	218,065
Victoria Island (Canada)	217,278
Ellesmere Island (Canada)	196,225

LAKES AND INLAND SEAS

Largest	Area (km ²)	Largest	Area (km ²)	Highest drop	Height (m)
Caspian Sea (Asia/Europe)	370,980	Sahara (Africa)	8,800,000	Angel Falls (Venezuela)	979
Lake Superior (N. America)	82,098	Gobi Desert (Asia)	1,300,000	Tugela Falls (South Africa)	948
Lake Victoria (Africa)	69,480	Australian Desert (Australasia)	1,250,000	Utgaard (Norway)	800
Aral Sea (Asia)	64,498	Arabian Desert (Asia)	850,000	Mongefossen (Norway)	774
Lake Huron (N. America)	59,566	Kalahari Desert (Africa)	580,000	Yosemite Falls (US)	739
Lake Michigan (N. America)	57,754	Chihuahuan Desert (N. America)	370,000	Mardalsfossen (Norway)	655
Lake Tanganyika (Africa)	52,891	Takla Makan Desert (Asia)	320,000	Cuquenén Falls (Venezuela)	610
Lake Baikal (Asia)	31,498	Kara Kum (Asia)	310,000	Sutherland Falls (New Zealand)	580
Great Bear Lake (N. America)	31,197	Namib Desert (Africa)	310,000	Ribbon Falls (US)	491
Lake Nyasa (Africa)	28,877	Thar Desert (Asia)	260,000	Gavarnie (France)	425

MOUNTAINS

Highest	Height (m)	Deepest	Depth (m)	Volume	(m ³ /sec)
Mt. Everest (Tibet/Nepal)	8,848	Reseau Jean Bernard (France)	1,602	Boyoma Falls (Zaire)	17,000
K2 (Pakistan/Tibet)	8,611	Shakta Pantjikhina (Georgia)	1,508	Guaira Falls (Brazil/Paraguay)	13,000
Kangchenjunga (India/Nepal)	8,598	Lamrechtsöfen (Austria)	1,485	Khone Falls (Laos)	11,500
Makalu (Tibet/Nepal)	8,480	Sistema del Trave (Spain)	1,441	Niagara Falls (Canada/US)	6,000
Cho Oyu (Tibet/Nepal)	8,201			Paulo Afonso Falls (Brazil)	2,800
Dhaulagiri (Nepal)	8,172	Longest system	Length (km)	Urubupunga Falls (Brazil)	2,700
Nanga Parbat (India)	8,126			Cataras del Iguazu Falls (Brazil/Paraguay)	1,700
Annapurna (Nepal)	8,078	Mammoth Cave System (US)	560	Patos-Maribondo Falls (Brazil)	1,500
Gasherbrum (India)	8,068	Optimisticheskaya (Ukraine)	183	Victoria Falls (Zimbabwe)	1,100
Xixabangma Feng (Tibet)	8,015	Hölloch (Switzerland)	137		
		Jewel Cave (US)	127		
		Ozernaya (Ukraine)	107		

ACTIVE VOLCANOES

Highest	Height (m)	EARTHQUAKE MEASUREMENT	
Gualltiri (Chile)	6,060	Mercalli Scale	Characteristics/possible damage
Lascar (Chile)	5,990	1	Not felt by people, but recorded by instruments; doors may swing slowly
Cotopaxi (Ecuador)	5,897	2-4	Felt by people indoors and some outdoors; hanging objects may swing
Tupungatito (Chile)	5,640	5-6	Felt by most or all outdoors; buildings tremble, books fall off shelves
Ruiz (Colombia)	5,400	7-8	General alarm; branches may fall off trees and it is difficult to drive
Sangay (Ecuador)	5,230	9-10	General panic; cracks appear in roads and buildings and bridges collapse
Purace (Colombia)	4,755	11-12	Few buildings standing, waves are seen in the ground, rivers may change course
Klyuchevskaya Sopka (Russia)	4,750		
Colima (Mexico)	4,268	Richter Scale	Probable effects
Galeras (Colombia)	4,266	1-3	Detectable only by instruments

RIVERS

Longest	Length (km)	4	Detectable within 32 km of epicenter
River Nile (Africa)	6,695	5	May cause slight damage
Amazon River (S. America)	6,437	6	Moderately destructive
Yangtze River/Chang Jiang (Asia)	6,379	7	A major earthquake
Mississippi-Missouri River (N. America)	6,264	8-9	A very destructive earthquake
River Ob-Irtysh (Asia)	5,411		
Yellow River/Huang He (Asia)	4,672		
River Congo/Zaire (Africa)	4,667		
River Amur (Asia)	4,416		
River Lena (Asia)	4,400		
Mackenzie-Peace River (N. America)	4,241		

WINDSPEED

Name	Length (km)	Beaufort Scale	Description	Speed (9 km/h)	Characteristics
Lambert-Fisher Ice Passage (Antarctic)	515	0	Calm	1	Smoke rises vertically
Novaya Zemlya (Russia)	418	1	Light air	1-5	Smoke blown by wind
Arctic Institute Ice Passage (Antarctica)	362	2	Light breeze	6-12	Leaves rustle
Nimrod-Lennox-King Ice Passage (Antarctica)	289	3	Gentle breeze	13-20	Extends a light flag
Denman Glacier (Antarctica)	241	4	Moderate breeze	21-29	Raises dust and loose paper
Beardmore Glacier (Antarctica)	225	5	Fresh breeze	30-39	Small trees sway
Recovery Glacier (Antarctica)	225	6	Strong breeze	40-50	Umbrellas are difficult to use
Petermanns Glacier (Greenland)	200	7	Moderate gale	51-61	Difficult to walk
Unnamed glacier (Antarctica)	193	8	Fresh gale	62-74	Twigs snap from trees
		9	Strong gale	75-87	Slates and chimneys blown away
		10	Whole gale	88-102	Trees uprooted
		11	Storm	103-120	Cars overturned, trees blown away
		12	Hurricane	120+	Buildings destroyed

Astronomical data

PLANETS OF THE SOLAR SYSTEM

	Mercury	Venus	Earth	Mars	Jupiter	Saturn	Uranus	Neptune	Pluto
Mass (Earth =1)	0.055	0.81	1	0.11	318	95.18	14.5	17.14	0.0022
Equatorial diameter (km)	4,878	12,103	12,756	6,786	142,984	120,536	51,118	49,528	2,300
Average density (g/cm ³ ; water = 1g/cm ³)	5.42	5.25	5.52	3.94	1.33	0.69	1.27	1.71	2.03
Axial tilt (degrees)	2	2	23.4	24	3.1	26.7	97.9	28.8	57.5
Rotational period (length of day) (d = Earth day, h = Earth hour)	58.65d	243.01d*	23.95h	24.62h	9.92h	10.67h	17.23h*	16.12h	6.38d*
Average surface temperature (° C)	-170 to 450	464	15	-40	-120	-180	-210	-220	-220
Maximum apparent magnitude	-1.4	-4.4	-	-2.8	-2.8	-0.3	5.5	7.8	13.6
Aphelion (million km)	69.7	109	152.1	249.1	815.7	1,507	3,004	4,537	7,375
Perihelion (million km)	45.9	107.4	147.1	206.7	740.9	1,347	2,735	4,456	4,425
Average distance from Sun (million km)	57.9	108.2	149.6	227.9	778.5	1,427	2,869.6	4,496	65,900
Orbital tilt (degrees)	7	3.39	0	1.85	1.3	2.49	0.77	1.77	17.2
Orbital period (length of year) (y = Earth year, d = Earth day)	87.97d	224.7d	365.26d	1.88y	11.86y	29.46y	84.01y	164.79y	248.54y

*denotes retrograde (backwards) spin

LOCAL GROUP OF GALAXIES

Name	Type	Distance (light years)	Luminosity (million Suns)	Diameter (light years)
Milky Way	Spiral	0	15,000	100,000
Large Magellanic Cloud	Irregular spiral	170,000	2,000	30,000
Small Magellanic Cloud	Irregular	190,000	500	20,000
Sculptor	Elliptical	300,000	1	6,000
Carina	Elliptical	300,000	0.01	3,000
Draco	Elliptical	300,000	0.1	3,000
Sextans	Elliptical	300,000	0.01	3,000
Ursa Minor	Elliptical	300,000	0.1	2,000
Fornax	Elliptical	500,000	12	6,000
Leo I	Elliptical	600,000	0.6	2,000
Leo II	Elliptical	600,000	0.4	2,000
NGC 6822	Irregular	1,800,000	90	15,000
IC 5152	Irregular	2,000,000	60	3,000
WLM	Irregular	2,000,000	90	6,000
Andromeda (M 31)	Spiral	2,200,000	40,000	150,000
Andromeda I,II,III	Elliptical	2,200,000	1	5,000
M 32 (NGC 221)	Elliptical	2,200,000	130	5,000
NGC 147	Elliptical	2,200,000	50	8,000
NGC 185	Elliptical	2,200,000	60	8,000
NGC 205	Elliptical	2,200,000	160	11,000
M 33 (Triangulum)	Spiral	2,400,000	5,000	40,000
IC 1615	Irregular	2,500,000	50	10,000
DDO 210	Irregular	3,000,000	2	5,000
Pisces	Irregular	3,000,000	0.6	2,000
GR 8	Irregular	4,000,000	2	1,500
IC 10	Irregular	4,000,000	250	6,000
Sagittarius	Irregular	4,000,000	1	4,000
Leo A	Irregular	5,000,000	20	7,000
Pegasus	Irregular	5,000,000	20	7,000

BRIGHTEST STARS

Name	Constellation	Apparent magnitude	Absolute magnitude	Distance (light years)	Star type
Sun		-26.7	4.8	0.000015*	Yellow main-sequence
Sirius A	Canis Major (The Great Dog)	-1.4	1.4	8.6	White main-sequence
Canopus	Carina (The Keel)	-0.7	-8.5	1,200	White supergiant
Alpha Centauri A	Centaurus (The Centaur)	-0.1	4.1	4.3	Yellow main-sequence
Arcturus	Boötes (The Herdsman)	-0.1	-0.3	37	Red giant
Vega	Lyra (The Lyre)	0.04	0.5	27	White main-sequence
Capella	Auriga (The Charioteer)	0.1	-0.6	45	Yellow giant
Rigel	Orion (The Huntsman)	0.1	-7.1	540-900	White supergiant
Procyon	Canis Minor (The Little Dog)	0.4	2.7	11.3	Yellow main-sequence
Achernar	Eridanus (River Eridanus)	0.5	-1.3	85	White main-sequence

* = 149,600,000 km

MOONS

Name of planet	Name of moon	diameter (km)	Distance from planet (km)
Earth	Moon	3,476	384,400
	Mars	Phobos 22*	9,400
Jupiter	Deimos	13*	23,500
	Metis	40*	128,000
	Adrastea	20*	129,000
	Amalthea	200	181,300
	Thebe	100*	221,900
	Io	3,642	421,800
	Europa	3,138	670,900
	Ganymede	5,262	1,070,000
	Callisto	4,800	1,880,000
	Leda	15	11,094,000
	Himalia	170	11,480,000
	Lysithea	35	11,720,000
	Elara	70	11,737,000
	Ananke	25	21,200,000
	Carme	40	22,600,000
Saturn	Pasiphae	60	25,500,000
	Sinope	40	25,700,000
	Pan	20	153,600
	Atlas	31*	137,700
	Prometheus	102*	139,400
	Pandora	85*	141,700
	Epimetheus	117	151,400
	Janus	188*	151,500
	Mimas	397	186,000
	Enceladus	498	238,000
	Tethys	1,050	295,000
	Telesto	22*	295,000
	Calypso	24*	295,000
	Dione	1,118	377,000
	Helene	32*	377,000
	Rhea	1,528	527,000
	Titan	5,150	1,222,000
	Hyperion	286*	1,481,100
	Uranus	Iapetus	1,436
Phoebe		22	12,954,000
Cordelia		26	49,700
Ophelia		32	53,800
Bianca		44	59,200
Cressida		66	61,800
Desdemona		58	62,700
Juliet		84	64,400
Portia		110	66,100
Rosalind		58	69,900
Belinda		68	75,300
Puck		154	86,000
Miranda		472	129,800
Ariel		1,158	191,200
Neptune	Umbriel	1,169	266,000
	Titania	1,578	435,900
	Oberon	1,523	582,600
	Naiad	54	48,000
	Thalassa	80	50,000
	Despina	180	52,500
	Galatea	150	62,000
	Larissa	192	73,600
	Proteus	416	117,600
	Triton	2,705	354,800
Pluto	Nereid	5005	514,000
	Charon	1,200	19,600

*denotes average diameter for irregularly shaped moon

**never look directly at the Sun

THE SUN

Feature	
Approximate age (billion years)	4.6
Star type	Yellow main-sequence
Mass (Earth = 1)	332,946
Equatorial diameter (km)	1,392,000
Average density (g/cm ³ ; water = 1g/cm ³)	1.41
Apparent magnitude	-26.7
Absolute magnitude	4.8
Luminosity (billion billion megawatts)	390
Average surface temperature (°C)	5,500
Approximate core temperature (°C)	15,000,000
Maximum distance from Earth (km)	152,100,000
Minimum distance from Earth (km)	147,100,000
Polar rotation period (Earth days)	35
Equatorial rotation period (Earth days)	25

FAMOUS COMETS

Name	Period (years)
D'Arrest's Comet	6.6
Encke's Comet	5.3
Comet Giacobini-Zinner	6.5
Great Comet of 1811	3,000
Great Comet of 1843	512.4
Great Comet of 1844	102,050
Hale-Bopp	3,000
Halley's Comet	76.3
Holmes' Comet	6.9
Comet Kohoutek	75,000
Comet Mrkós	5.3
Pons-Winnecke Comet	6
Comet Schwassmann-Wachmann	16.2

TOTAL SOLAR ECLIPSES (UNTIL 2010)

Date	Where visible **
February 26, 1998	Mid-Pacific, Central America, North Atlantic
August 11, 1999	North Atlantic, North Europe, Western Asia, North India
June 21, 2001	South America, South Atlantic, Southern Africa, Pacific
December 4, 2002	Mid-Atlantic, Southern Africa, South Pacific, Australia
November 23, 2003	South Pacific, Antarctica
April 8, 2005	Mid-Pacific, Central America
March 29, 2006	Central Africa, Western Asia, parts of China
August 1, 2008	Arctic and Siberia
July 22, 2009	Mid-Atlantic, North America

TOTAL LUNAR ECLIPSES (UNTIL 2010)

Date	Where visible
January 21, 2000	North, South, and Central America, Southwest Europe, West Africa
July 16, 2000	Pacific, Australia, Southeast Asia
January 9, 2001	Africa, Asia, Europe
May 16, 2003	South and Central America, Antarctica
November 9, 2003	North, South, and Central America
May 4, 2004	Africa, Western Asia, India
October 28, 2004	North, South, and Central America, West Africa, southern Europe
March 3, 2007	Europe, Africa, Arctic
August 28, 2007	Southeastern tip of Australia, Pacific Ocean
February 21, 2008	North, Central, and South America, West Africa, Northwestern Europe
December 21, 2010	North and Central America, Pacific Ocean

Stars of the northern skies

MAJOR NORTHERN CONSTELLATIONS

Latin name	Alternative name
Andromeda	Andromeda
*Aquila	Eagle
Aries	Ram
Auriga	Charioteer
Boötes	Herdsman
Cancer	Crab
Canis Minor	Little Dog
Cassiopeia	Cassiopeia
Cepheus	Cepheus
Cygnus	Swan
Draco	Dragon
Gemini	Twins
Hercules	Hercules
*Hydra	Water Snake
Leo	Lion
Lyra	Lyre
Ophiuchus	Serpent Holder
Orion	Hunter
Pegasus	Pegasus
Pisces	Fishes
*Serpens	Serpent
*Sextans	Sextant
Taurus	Bull
Ursa Major	Great Bear
Ursa Minor	Little Bear
*Virgo	Virgin

VISIBLE STARS IN THE NORTHERN SKY

Constellations in this table are found in the northern celestial hemisphere. Those marked * lie on or near the celestial equator.

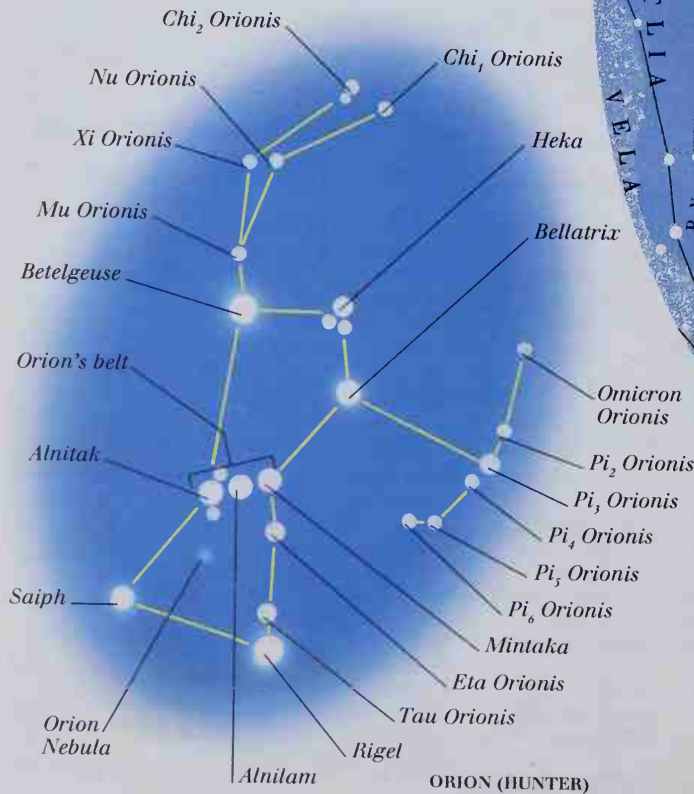

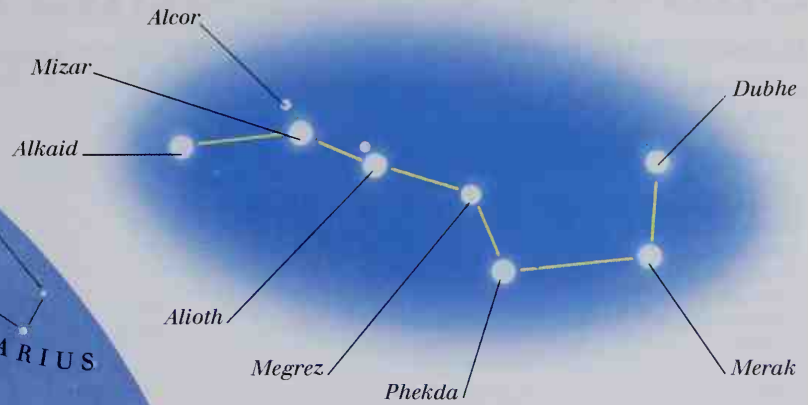

THE BIG DIPPER, PART OF URSA MAJOR (GREAT BEAR)

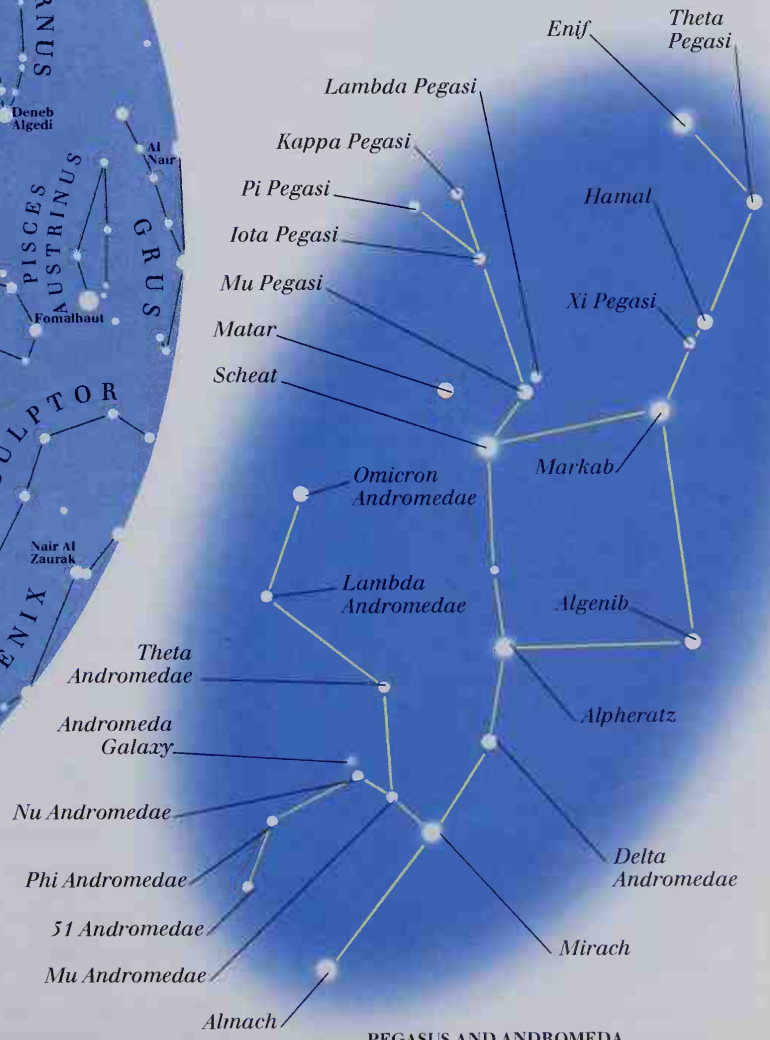

PEGASUS AND ANDROMEDA

Stars of the southern skies

MAJOR SOUTHERN CONSTELLATIONS

Latin name	Alternative name
Apus	Bird of Paradise
Aquarius	Water Bearer
*Aquila	Eagle
Canis Major	Great Dog
Capricornus	Sea Goat
Centaurus	Centaur
Chamaeleon	Chameleon
Columba	Dove
Corona Australis	Southern Crown
Corvus	Crow
Crater	Cup
Crux	Southern Cross
Dorado	Swordfish
Eridanus	River Eridanus
Fornax	Furnace
Grus	Crane
*Hydra	Water Snake
Lepus	Hare
Libra	Scales
Lupus	Wolf
Mensa	Table Mountain
Microscopium	Microscope
Pavo	Peacock
Phoenix	Phoenix
Pisces Austrinus	Southern Fish
Sagittarius	Archer
Scorpius	Scorpion
Sculptor	Sculptor
*Serpens	Serpent
*Sextans	Sextant
Triangulum Australe	Southern Triangle
Tucana	Toucan
Vela	Sail
*Virgo	Virgin
Volans	Flying Fish

VISIBLE STARS IN THE SOUTHERN SKY

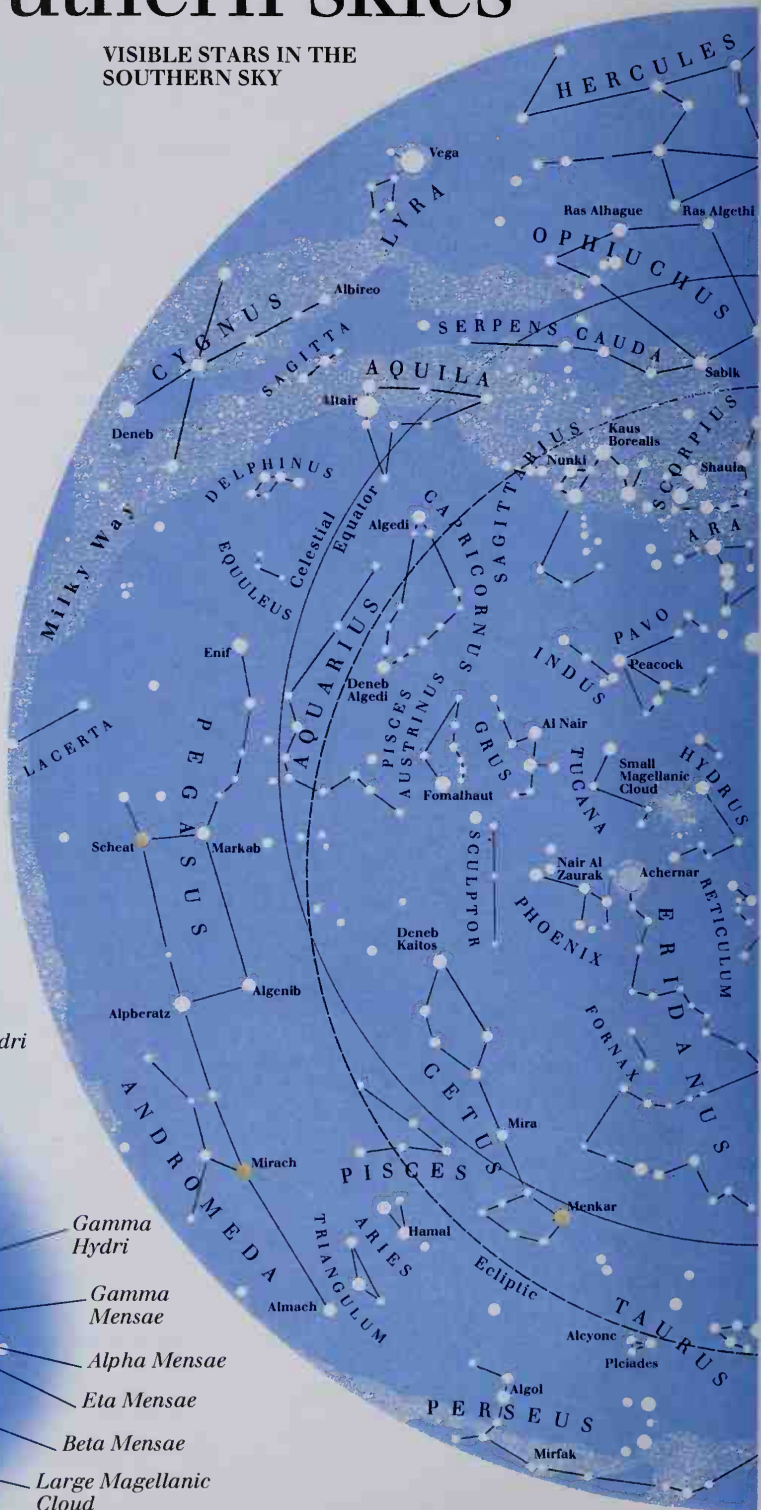

Constellations in this table are found in the southern celestial hemisphere. Those marked * lie on or near the celestial equator.

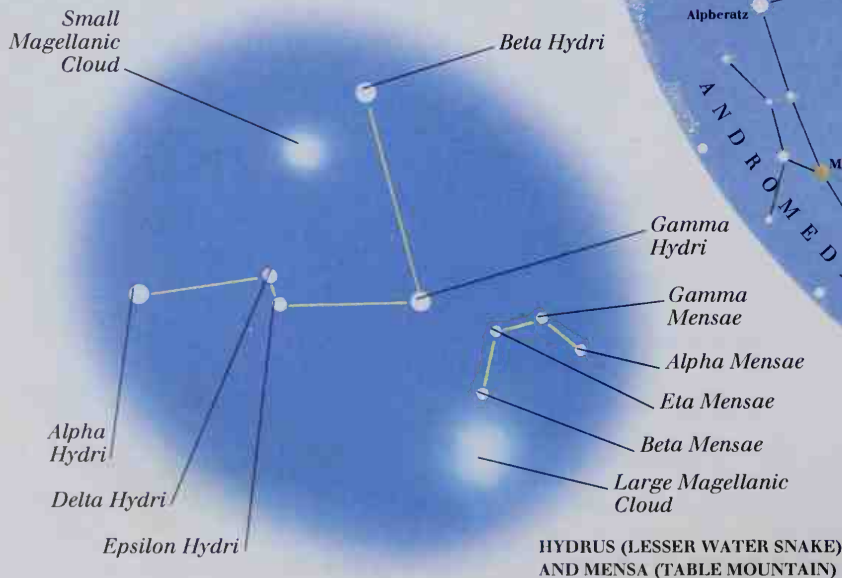



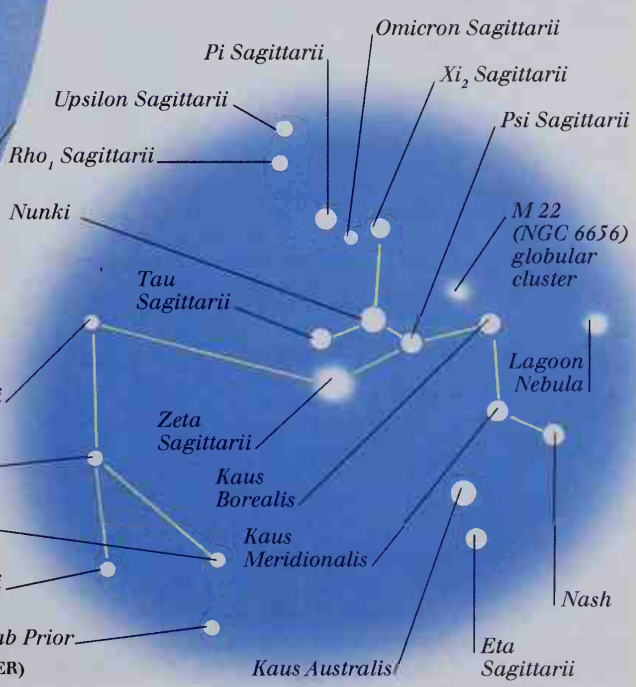
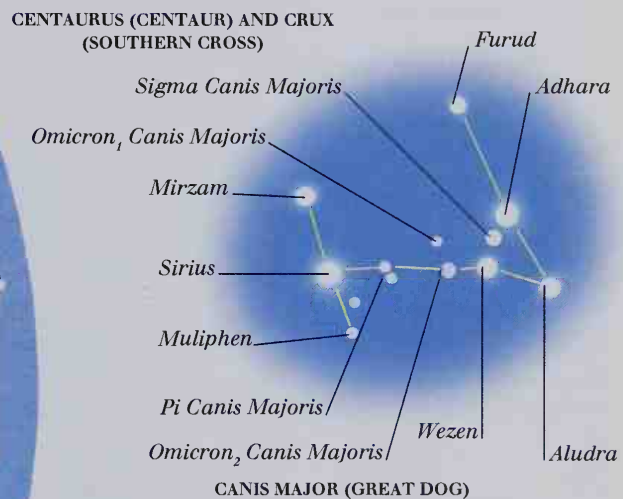
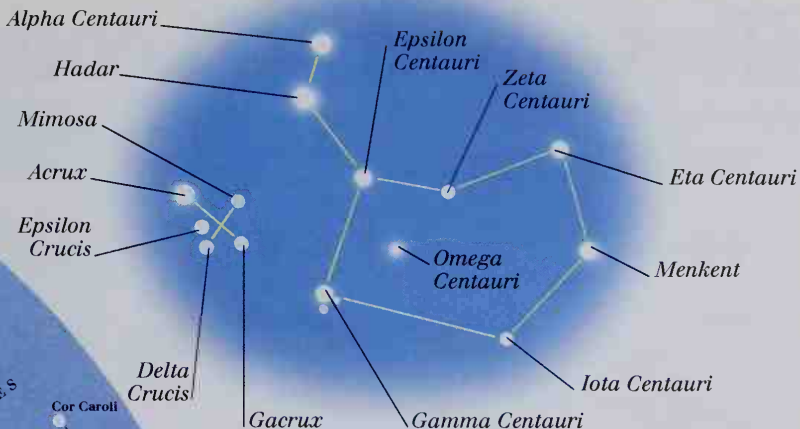
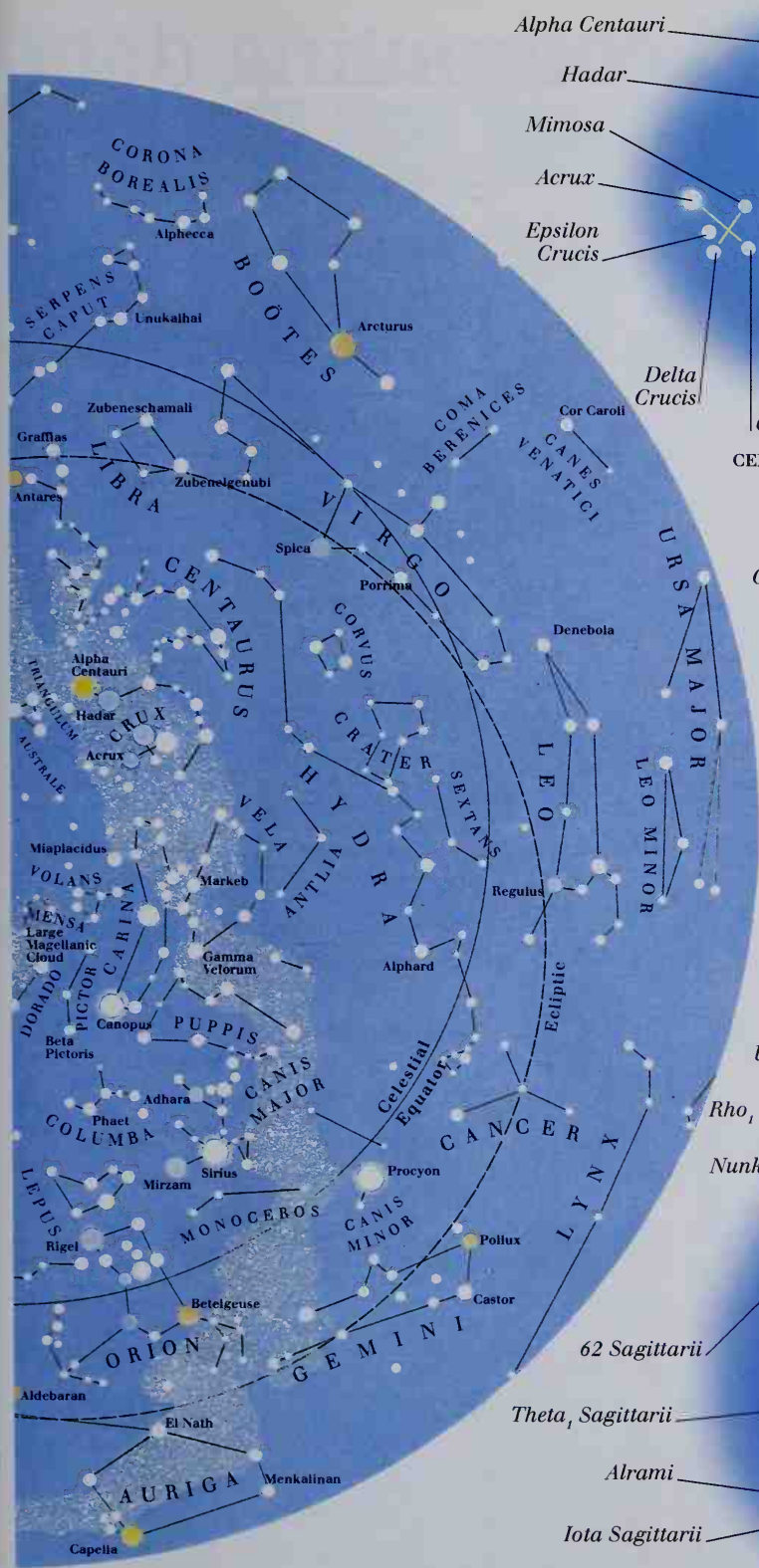









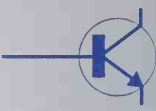







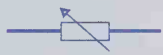

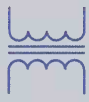

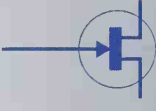



HYDRUS (LESSER WATER SNAKE) AND MENSA (TABLE MOUNTAIN)



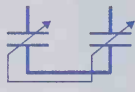





Electronics and computing data

ELECTRONIC CIRCUIT SYMBOLS

General	Resistors and transformers	Capacitors	Inductors	Diodes	Transistors
					
Battery	Resistor	Capacitor	Inductor	Diode	NPN transistor
					
Switch	Thermistor	Electrolytic capacitor	Inductor with core	LED (light-emitting diode)	PNP transistor
					
Junction	Variable resistor	Variable capacitor	Transformer	Photodiode	JFET transistor
					
Wires crossing	Potential divider	Preset capacitor	Three-winding transformer	Esaki diode	Mosfet transistor
					
Bulb	Light-dependent resistor	2-gang variable capacitor	Variable inductor	Zener diode	Unijunction transistor

EXAMPLES OF LOGIC GATES

OR gate	NAND gate	NOR gate	XOR gate	XNOR gate	NOT gate																																																																																	
																																																																																						
The OR gate gives an output of logic 1 when any or all of its inputs are at logic 1.	This is the inverse of an AND gate. Output Q is zero only if both inputs, A and B, are 1.	This is the inverse of the OR gate. Output Q is 1 only if neither input A nor B is 1.	XOR stands for exclusive OR. Output Q is 1 only if either, but not both, inputs are 1.	XNOR stands for exclusive NOR. Output Q is zero if either, but not both, inputs are 1.	Also known as an inverter, this gate has one input. Output Q is the inverse of input A.																																																																																	
<table border="1"> <thead> <tr><th>A</th><th>B</th><th>Q</th></tr> </thead> <tbody> <tr><td>0</td><td>0</td><td>0</td></tr> <tr><td>0</td><td>1</td><td>1</td></tr> <tr><td>1</td><td>0</td><td>1</td></tr> <tr><td>1</td><td>1</td><td>1</td></tr> </tbody> </table>	A	B	Q	0	0	0	0	1	1	1	0	1	1	1	1	<table border="1"> <thead> <tr><th>A</th><th>B</th><th>Q</th></tr> </thead> <tbody> <tr><td>0</td><td>0</td><td>1</td></tr> <tr><td>0</td><td>1</td><td>1</td></tr> <tr><td>1</td><td>0</td><td>1</td></tr> <tr><td>1</td><td>1</td><td>0</td></tr> </tbody> </table>	A	B	Q	0	0	1	0	1	1	1	0	1	1	1	0	<table border="1"> <thead> <tr><th>A</th><th>B</th><th>Q</th></tr> </thead> <tbody> <tr><td>0</td><td>0</td><td>1</td></tr> <tr><td>0</td><td>1</td><td>0</td></tr> <tr><td>1</td><td>0</td><td>0</td></tr> <tr><td>1</td><td>1</td><td>0</td></tr> </tbody> </table>	A	B	Q	0	0	1	0	1	0	1	0	0	1	1	0	<table border="1"> <thead> <tr><th>A</th><th>B</th><th>Q</th></tr> </thead> <tbody> <tr><td>0</td><td>0</td><td>0</td></tr> <tr><td>0</td><td>1</td><td>1</td></tr> <tr><td>1</td><td>0</td><td>1</td></tr> <tr><td>1</td><td>1</td><td>0</td></tr> </tbody> </table>	A	B	Q	0	0	0	0	1	1	1	0	1	1	1	0	<table border="1"> <thead> <tr><th>A</th><th>B</th><th>Q</th></tr> </thead> <tbody> <tr><td>0</td><td>0</td><td>1</td></tr> <tr><td>0</td><td>1</td><td>0</td></tr> <tr><td>1</td><td>0</td><td>0</td></tr> <tr><td>1</td><td>1</td><td>1</td></tr> </tbody> </table>	A	B	Q	0	0	1	0	1	0	1	0	0	1	1	1	<table border="1"> <thead> <tr><th>A</th><th>Q</th></tr> </thead> <tbody> <tr><td>0</td><td>1</td></tr> <tr><td>1</td><td>0</td></tr> </tbody> </table>	A	Q	0	1	1	0
A	B	Q																																																																																				
0	0	0																																																																																				
0	1	1																																																																																				
1	0	1																																																																																				
1	1	1																																																																																				
A	B	Q																																																																																				
0	0	1																																																																																				
0	1	1																																																																																				
1	0	1																																																																																				
1	1	0																																																																																				
A	B	Q																																																																																				
0	0	1																																																																																				
0	1	0																																																																																				
1	0	0																																																																																				
1	1	0																																																																																				
A	B	Q																																																																																				
0	0	0																																																																																				
0	1	1																																																																																				
1	0	1																																																																																				
1	1	0																																																																																				
A	B	Q																																																																																				
0	0	1																																																																																				
0	1	0																																																																																				
1	0	0																																																																																				
1	1	1																																																																																				
A	Q																																																																																					
0	1																																																																																					
1	0																																																																																					

RESISTOR COLOR CODES

1st digit	2nd digit	3rd digit	Multiplier	Tolerance
0	0	0	1	1%
1	1	1	10	2%
2	2	2	100	
3	3	3	1000	
4	4	4	10000	
5	5	5	100000	
6	6	6	1000000	
7	7	7		5%
8	8	8	0.1	10%
9	9	9	0.01	

RESISTOR VALUES

Code	Value
1R2	1.2 Ω
12R	12 Ω
120R	120 Ω
1K	12 kΩ
120K	120 kΩ
1M2	1.2 MΩ
12M	12 MΩ

CIRCUIT FORMULAS

Formulas	Comments
$R=R_1+R_2+\dots$	Resistors in series
$1/R=1/R_1+1/R_2+\dots$	Resistors in parallel
$C=C_1+C_2+\dots$	Capacitors in parallel
$1/C=1/C_1+1/C_2+\dots$	Capacitors in series

ELECTRONICS AND COMPUTER ABBREVIATIONS

Abbreviation	Meaning	Decimal number	Binary	Hexa-decimal	ASCII code	ASCII character
A	Ampere	0	00000000	00	00000000	NUL*
A.C.	Alternating current	1	10000001	01	10000001	SOH*
AF	Audio frequency	2	10000010	02	10000010	Start of text*
AM	Amplitude modulation	9	00001001	09	00001001	HT*
CD-ROM	Compact-disc read-only memory	10	00001010	0A	00001010	Line feed*
CPU	Central processing unit	11	00001011	0B	10001011	VT*
CRT	Cathode ray tube	12	00001100	0C	00001100	Form feed*
dB	Decibel	13	00001101	0D	10001101	Carriage return*
D.C.	Direct current	14	00001110	0E	10001110	SO*
DOS	Disk-operating system	15	00001111	0F	00001111	SI*
DRAM	Dynamic random-access memory	16	00010000	10	10010000	DLE*
e-mail	Electronic mail	17	00010001	11	00010001	DC1*
e.m.f.	Electromotive force	18	00010010	12	00010010	DC2*
EPROM	Erasable programmable read-only memory	32	00100000	20	10100000	SPACE
F	Farad	33	00100001	21	00100001	!
FM	Frequency modulation	34	00100010	22	00100010	"
GSM	Global system mobile	64	01000000	40	11000000	@
hi-fi	High fidelity	65	01000001	41	01000001	A
I	Current	66	01000010	42	01000010	B
IC	Integrated circuit	119	01110111	77	01110111	w
k (kb, kB)	Kilobyte (1024 bytes)	120	01111000	78	01111000	x
kbps	Kilobits per second	121	01111001	79	11111001	y
LCD	Liquid crystal display	122	01111010	7A	11111010	z
LED	Light-emitting diode	123	01111011	7B	01111011	{

* control characters (nonprinting)

GENERATIONS OF COMPUTER

Generation	Dates	Characteristic
1st	1944-59	Used valves (vacuum tubes)
2nd	1959-64	Used transistors
3rd	1964-75	Large-scale Integrated Circuits (LSI)
4th	1975-	Very Large-scale Integrated Circuits (VLSI)
5th	Under development	Artificial intelligence

Mathematics data

SHAPES

Plane shapes

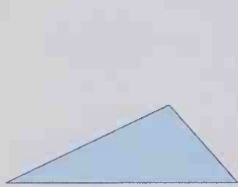

SCALED TRIANGLE
A triangle (three-sided polygon) with no equal sides or angles.



ISOCELES TRIANGLE
A triangle with only two sides and two angles equal.



RIGHT-ANGLED TRIANGLE
A triangle with one angle as a right angle (90°).

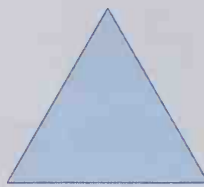

EQUILATERAL TRIANGLE
A regular triangle. All angles are 60° .

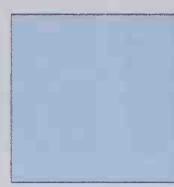

SQUARE
A regular quadrilateral. All angles are 90° .

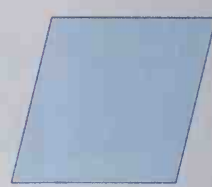

RHOMBUS
A quadrilateral with all sides equal and two pairs of equal angles.

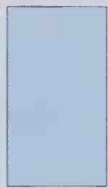

RECTANGLE
A quadrilateral with four right angles and opposite sides of equal length.

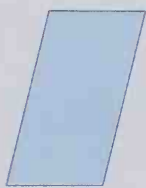

PARALLELOGRAM
A quadrilateral with two pairs of parallel sides.

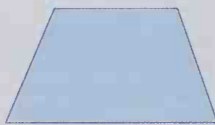

TRAPEZIUM
A quadrilateral with one pair of parallel sides.

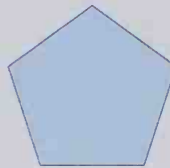

PENTAGON
A five-sided polygon. A regular pentagon is shown above.

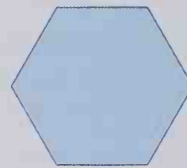

HEXAGON
A six-sided polygon. A regular hexagon is shown above.

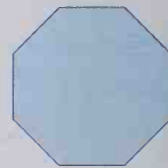

OCTAGON
An eight-sided polygon. A regular octagon is shown above.

Solid shapes

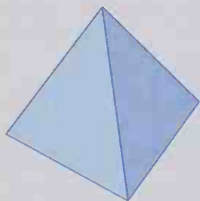

TETRAHEDRON
A four-sided polyhedron. A regular tetrahedron is shown.

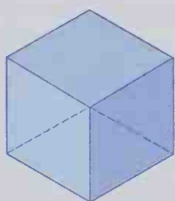

CUBE
A regular hexahedron. All sides are equal and all angles are 90° .



OCTAHEDRON
A polyhedron with eight sides.

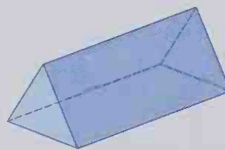

PRISM
A polyhedron of constant cross-section in planes perpendicular to its longitudinal axis.

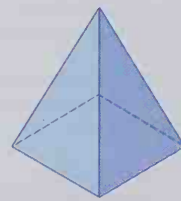

PYRAMID
A polygonal base and triangular sides that meet at a point.



TORUS
A doughnutlike, ring shape.

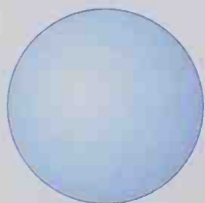

SPHERE
A round shape, as in a ball or an orange.

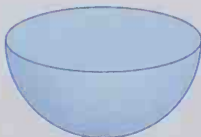

HEMISPHERE
Formed when a sphere is cut exactly in half.



SPHEROID
An egg-shaped object whose cross-section is a circle or an ellipse.

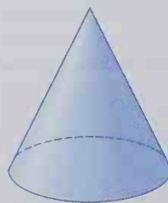

CONE
An elliptical or circular base with sides tapering to a single point.

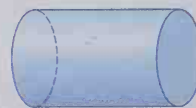

RIGHT CYLINDER
A tube-shaped, solid figure. A right cylinder has parallel faces.



HELIX
A twisted curve. The distance moved in one revolution is its pitch.

AREAS AND VOLUME

Plane shapes

Radius = r
Diameter = $d = 2 \times r$

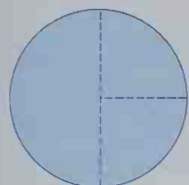

CIRCLE

Circumference = $2 \times \pi \times r$

Area = $\pi \times r^2$

Height = h , Base = b
Sides = a, b, c

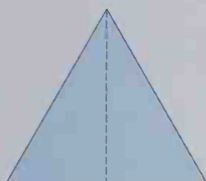

TRIANGLE

Perimeter = $a + b + c$

Area = $\frac{1}{2} \times b \times h$

Sides = a, b



RECTANGLE

Perimeter = $2 \times (a + b)$

Area = $a \times b$

Solid shapes

Height = h
Radius = r

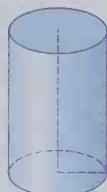

CYLINDER

Surface area = $2 \times \pi \times r \times h$ (excl. bases)

Volume = $\pi \times r^2 \times h$

Height = h
Radius = r , Side = l

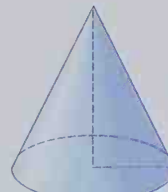

CONE

Surface area = $\pi \times r \times l + \pi r^2$

Volume = $\frac{1}{3} \times \pi \times r^2 \times h$

Sides = a, b, c

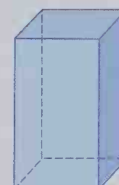

RECTANGULAR BLOCK

Surface area = $2(a \times b + b \times c + a \times c)$

Volume = $a \times b \times c$

MATHEMATICAL SYMBOLS

Symbol	Explanation
+	addition
-	subtraction
×	multiplication
÷	division
=	equals
≠	does not equal
>	greater than
<	less than
≥	greater than or equal to
≤	less than or equal to
∞	infinity
∑	summation
$\mathbf{u, \underline{u}}$	vectors
$\mathbf{f(x)}$	function
!	factorial
√	square root
∅	universal set
$\mathbf{A \cap B}$	intersection
$\mathbf{A \cup B}$	union
$\mathbf{A \subset B}$	subset
∅	null set

SCIENTIFIC NOTATION

Number	Number between 1 and 10	Power of ten	Scientific notation
10	1	10^1	1×10^1
150	1.5	$10^2 (= 100)$	1.5×10^2
274,000,000	2.74	$10^8 (= 100,000,000)$	2.74×10^8
0.0023	2.3	$10^{-5} (= 0.001)$	2.3×10^{-5}

TRIGONOMETRY

Angle A (degrees)	sin A	cos A	tan A
0	0	1	0
30	1/2	$\sqrt{3}/2$	$1/\sqrt{3}$
45	$1/\sqrt{2}$	$1/\sqrt{2}$	1
60	$\sqrt{3}/2$	1/2	$\sqrt{3}$
90	1	0	∞

RULES OF ALGEBRA

Expression	Comments	Expression becomes
$a + a$	Simple addition	$2a$
$a + b = c + d$	Subtract b from either side	$a = c + d - b$
$ab = cd$	Divide both sides by b	$a = cd/b$
$(a + b)(c + d)$	Multiplication of bracketed terms	$ac + ad + bc + bd$
$a^2 + ab$	Use parentheses	$a(a + b)$
$(a + b)^2$	Expand parentheses	$a^2 + 2ab + b^2$
$a^2 - b^2$	Difference of two squares	$(a + b)(a - b)$
$1/a + 1/b$	Find common denominator	$(a + b)/ab$
$a/b \div c/d$	Dividing by a fraction is the same as multiplying by its reciprocal	$a/b \times d/c$

Biographies

The names featured here relate directly to the scientists highlighted in bold in the historical sections of the book.

JEAN LOUIS AGASSIZ
(1807 - 1873)

Swiss geologist and zoologist who studied the effects of ice erosion and proved that glaciers move.

GEORGIUS AGRICOLA, ALSO KNOWN AS GEORG BAUER
(1494 - 1555)

German geologist and mining engineer who was the first person to study rocks and minerals in a scientific way.

ALCMAEON OF CROTON
(c. 520 BC)

Ancient Greek physician and philosopher, generally considered to be the first anatomist.

ANAXIMANDER OF MILETUS
(c. 611 - 546 BC)

Ancient Greek natural philosopher, among whose reputed contributions to science are an accurate sundial, the earliest map of the Earth, and a primitive theory of evolution.

APOLLONIUS OF PERGA
(3RD CENTURY BC)

Ancient Greek mathematician noted for his work on an important set of curves called conic sections. He also used mathematics in attempts to account for the motions of the known planets.

ARCHIMEDES
(c. 287 - 212 BC)

Greek mathematician and engineer. He derived mathematical formulas for various geometrical shapes and discovered the principle of upthrust on an object floating in water. He also studied simple machines, in particular the screw thread.

ARISTOTLE
(384 - 322 BC)

Influential Greek philosopher and naturalist. Wrote extensively on force and motion, plant and animal classification, and many other subjects. His ideas were believed to be fact by most religious thinkers, at least until the 17th century.

HEINRICH LOUIS D'ARREST
(1822 - 1875)

German astronomer involved in the discovery of Neptune and famous for his studies of asteroids and nebulae.

SVANTE ARRHENIUS
(1859 - 1927)

Swedish chemist who won the 1903 Nobel prize for his work on the dissociation (splitting) of molecules into ions in solution.

JOHN VINCENT ATANASOFF
(BORN 1903)

American physicist and computer pioneer who, with Clifford Berry, built one of the first electronic computers.

CHARLES BABBAGE
(1792 - 1871)

English mathematician who invented a sophisticated calculating machine (the Difference Engine) that eliminated errors from tables of mathematical figures.

THOMAS BARTHOLIN
(1616 - 1680)

Danish physician (doctor) and mathematician. The first person to produce a detailed description of the human lymphatic system.

WILLIAM MADDOCK BAYLISS
(1860 - 1924)

English physiologist who, with his colleague **Ernest Starling**, first used the word "hormone," after discovering secretin in 1902.

WILLIAM BEAUMONT
(1796 - 1853)

American army surgeon who was the first person to observe and study human digestion, after working on a patient with a shotgun wound.

CHARLES BELL
(1774 - 1842)

Scottish anatomist and surgeon who discovered the distinction between sensory and motor neurons (nerves).

JOCELYN BELL BURNELL
(BORN 1943)

English radio astronomer who detected regular pulses of radio waves from outer space. The source of the radio signal was later shown to be from the first-discovered pulsar.

CLAUDE BERNARD (1813 - 1878)

French physiologist who established the concept of homeostasis, whereby the internal chemical environment of the human body resists dramatic fluctuations of temperature or composition.

FRIEDRICH WILHELM BESSEL
(1784 - 1864)

German mathematician and astronomer whose calculation of the distance of the double star, 61 Cygni, was the first scientific reckoning of stellar distance.

HANS ALBRECHT BETHE
(BORN 1906)

German physicist who figured out the role of nuclear fusion in stars.

VILHELM BJERKNES
(1862 - 1951)

Norwegian meteorologist whose theory of weather fronts (boundaries between air masses) was the foundation of modern weather forecasting.

GEORGE BOOLE
(1815 - 1864)

English mathematician whose system of mathematical logic (Boolean algebra) has had a profound influence on the development of modern electronic computers.

HERBERT WAYNE BOYER
(BORN 1936)

American biochemist. In 1973, with **Stanley Cohen**, successfully spliced two sections of DNA from a bacterium, heralding the beginning of genetic engineering.

ROBERT BOYLE
(1627 - 1691)

Irish physicist who is famous for his work on gases. He was also the first to produce a modern definition of an element.

TYCHO BRAHE
(1546 - 1601)

Danish astronomer, famous for his accurate observations. These were utilized by **Copernicus** in his heliocentric (sun-centered) theory of the Solar System.

ROBERT WILHELM BUNSEN
(1811 - 1899)

German chemist and physicist whose name is given to the gas burner he invented. With **Gustav Kirchoff**, he was also a pioneer of spectroscopy.

GEORG FERDINAND LUDWIG PHILIP CANTOR
(1845 - 1918)

German mathematician who made important contributions to set theory.

HENRY CAVENDISH
(1731 - 1810)

English scientist, most famous for his work on gases. He was the first to isolate oxygen gas, and built sensitive apparatus for determining the density of the Earth.

CELSUS
(1ST CENTURY AD)

Roman scholar and writer who wrote extensively on medical topics. His ideas were rejected by **Paracelsus**, whose self-appointed name means "against Celsus."

JOHN DOUGLAS COCKCROFT
(1897 - 1967)

English nuclear physicist who in 1924, with **Ernest Walton**, succeeded in disintegrating lithium atoms by bombarding them with high-energy protons.

SEYMOUR STANLEY COHEN
(BORN 1917)

American biochemist who, with **Herbert Boyer**, pioneered genetic engineering in the 1970s.

NICOLAUS COPERNICUS
(1473 - 1543)

Polish astronomer who founded modern astronomy by being the first to suggest that the Earth is not at the center of the Universe. His suggestion that the Earth moves around the Sun inspired **Galileo**, **Newton**, and **Kepler**.

FRANCIS HARRY COMPTON CRICK
(BORN 1916)

English molecular biologist famous for figuring out the molecular structure of DNA with his colleague, **James Watson**.

WILLIAM CROOKES (1832 - 1919)

English chemist and physicist. The Crookes tube, important in the discovery of the electron, is named after him.

GEORGES CUVIER
(1769 - 1832)

French anatomist whose work on animal classification was based on the structure of animals' bodies. He also founded paleontology (the scientific study of fossils).

JOHN DALTON
(1766 - 1844)

English scientist and originator of modern atomic theory. He discovered the law of partial pressures, known as Dalton's Law.

CHARLES ROBERT DARWIN
(1809 - 1882)

English naturalist, geologist, and physician (doctor) who developed the theory of evolution, discussed in *The Origin of Species*, while on an expedition to the Galapagos Islands aboard the ship the *HMS Beagle*.

HUMPHREY DAVY
(1778 - 1829)

English chemist, most famous for his work on electrochemistry and his invention of the miner's safety lamp.

- DEMOCRITUS**
(c. 460 - 370 BC)
Greek philosopher and mathematician who was the first to construct a comprehensive atomic theory.
- RENE DESCARTES**
(1596 - 1650)
Prolific French natural philosopher who studied many branches of science and mathematics.
- THOMAS ALVA EDISON**
(1847 - 1931)
American inventor, one of those responsible for the development of electric lighting.
- PAUL EHRLICH**
(1854 - 1915)
German biologist, a pioneer of hematology (study of the blood), and immunology (study of the immune system). He coined the term "chemotherapy."
- ALBERT EINSTEIN**
(1879 - 1955)
German-born American physicist generally regarded as one of history's greatest scientists. He is most famous for his special and general theories of relativity, for which he won the Nobel Prize in 1921.
- WILLEM EINTHOVEN**
(1860 - 1927)
Dutch physiologist, inventor of the first electrocardiogram (ECG) machine in 1903.
- EMPEDOCLES**
(c. 450 BC)
Ancient Greek philosopher and poet who was one of the originators of the theory of the four elements.
- ERATOSTHANES**
(c. 275 - 192 BC)
Greek philosopher, mathematician, and astronomer who was the first to figure out scientifically a value for the size of the Earth.
- EUCLID**
(c. 300 BC)
Greek mathematician, best known for his comprehensive work on geometry.
- BARTOLOMMEO EUSTACHIO**
(1520 - 1574)
Italian pioneer of modern anatomy.
- HIERONYMUS FABRICIUS,**
ALSO KNOWN AS
GIROLAMO FABRICI
(1537 - 1619)
Italian anatomist who studied the valves in veins. He was a tutor of William Harvey.
- CHARLES FABRY**
(1867 - 1945)
French physicist and discoverer of the ozone layer. He was the co-inventor of the Fabry-Perot interferometer, a device that measures the wavelengths of light.
- MICHAEL FARADAY**
(1791 - 1867)
English experimental physicist and chemist who originated the idea of magnetic and electric fields. His work was put into mathematical form by Maxwell. Faraday also invented the dynamo and discovered electromagnetic induction.
- ENRICO FERMI**
(1901 - 1954)
Italian physicist who used the work of Lise Meitner and others to build the world's first nuclear reactor.
- ALEXANDER FLEMING**
(1881 - 1955)
Scottish biologist who conducted research into bacteria. He discovered the antibiotic penicillin in 1928.
- JOHN AMBROSE FLEMING**
(1849 - 1945)
English inventor who developed the thermionic valve, a forerunner of the modern semiconductor diode.
- GALEN**
(c. 129 - 199)
Greek anatomist, an expert at dissecting animals and working out muscle and bone structures.
- GALILEO GALILEI**
(1564 - 1642)
Italian astronomer and founder of classical physics, whose work on force and motion challenged that of Aristotle. In 1609, he became the first to use a telescope to observe craters on the Moon and four of the satellites of Jupiter.
- JOHANN GOTTFRIED GALLE**
(1812 - 1910)
German astronomer who was the first to observe the planet Neptune, working from calculations made by Heinrich D'Arrest.
- LUIGI GALVANI**
(1757 - 1798)
Italian physiologist whose studies of the relationship between nerves, muscles, and electricity were the beginning of the study of electrophysiology.
- MURRAY GELL-MANN**
(BORN 1929)
American theoretical physicist who was the first to hypothesize the existence of quarks.
- WILLIAM GILBERT**
(1540 - 1603)
English physician and experimenter who is known for his work on electricity and magnetism.
- FRANCIS GLISSON**
(c. 1597 - 1677)
English anatomist and physician who made a detailed study of the human liver.
- KURT GÖDEL**
(1906 - 1978)
Austrian-born American mathematician, famous for Gödel's theorem, which is an important part of the study of mathematical logic.
- CAMILLO GOLGI**
(1845 - 1926)
Italian cell biologist known for his study of the structure of the nervous system. He also discovered tiny structures within cells, called Golgi bodies.
- NEHEMIAH GREW**
(1641 - 1712)
English botanist and physician. He introduced the term "comparative anatomy," where the anatomy of a plant is compared with that of another plant or an animal.
- BENO GUTENBERG**
(1889 - 1960)
German-born American seismologist, among the first to suggest that the Earth's core is molten. Together with Charles Richter, he devised a scale for measuring the strength of earthquakes.
- GEORGE HADLEY**
(1685 - 1768)
English physicist and meteorologist who described global patterns of wind circulation, now called Hadley cells.
- ERNST HEINRICH PHILIPP AUGUST HAECKEL**
(1854 - 1919)
German biologist whose extensive zoological and botanical researches led him to coin the term "ecology."
- OTTO HAHN**
(1879 - 1968)
German physicist who, with Fritz Strassmann, was a co-discoverer of nuclear fission.
- EDMUND HALLEY**
(1656 - 1742)
English astronomer who was the first to discover the fact that some comets return on a regular basis. Halley's comet is named after him.
- WILLIAM HARVEY**
(1578 - 1657)
English anatomist who formulated the theory of blood circulation through arteries and veins.
- OLIVER HEAVISIDE**
(1850 - 1925)
English physicist who made important contributions to telegraphy and earth science. He suggested the existence of a layer of charged particles, now called the ionosphere.
- FRIEDRICH GUSTAV JAKOB HENLE**
(1809 - 1885)
German anatomist who discovered tubules in the kidney, named Henle's loops in his honor.
- JOSEPH HENRY**
(1797 - 1878)
American physicist who discovered electromagnetic induction independently of Michael Faraday. The unit of inductance is named after him.
- WILLIAM HERSCHEL**
(1758 - 1822)
German astronomer, best remembered for his discovery of the planet Uranus.
- HEINRICH RUDOLF HERTZ**
(1857 - 1894)
German experimental physicist. In 1888, he discovered radio waves, confirming Maxwell's theory of electromagnetic radiation.
- HARRY HAMMOND HESS**
(1906 - 1969)
American geophysicist who discovered seafloor spreading, an important factor in the theory of plate tectonics.
- HIPPARCHUS**
(2ND CENTURY BC)
Ancient Greek astronomer who made many important astronomical measurements, including a fairly accurate determination of the sizes of the Sun and the Moon.
- HIPPOCRATES**
(c. 460 - 370 BC)
Greek physician (doctor) who created the Hippocratic Oath - a code of conduct for doctors. A form of the oath is still used today.
- ROBERT HOOKE**
(1635 - 1705)
English physicist, chemist, and biologist who formulated Hooke's Law, relating to the extension or compression of a solid to the force applied to it. He also coined the term "cells," after observing plant cells under a microscope and likening them to rooms in a prison.

EDWIN POWELL HUBBLE
(1889 - 1955)

American astronomer who is remembered for his calculation of the immense distance of the Andromeda galaxy. The *Hubble Space Telescope* is named after him.

JOHN HUNTER
(1728 - 1793)

Scottish anatomist and biologist who founded experimental medicine. He pioneered the art of grafting tissue.

JAMES HUTTON
(1726 - 1797)

Scottish geologist who was the first to take a scientific approach to the subject.

JAN INGEN-HOUSZ
(1750 - 1799)

Dutch botanist who, inspired by Joseph Priestley's discovery that plants produce oxygen, demonstrated photosynthesis.

CHARLES JACKSON
(1805 - 1880)

American doctor, chemist, and earth scientist. He was one of the first to use ether as an anesthetic during surgical operations.

KARL JANSKY
(1905 - 1950)

American engineer and pioneer of radio astronomy.

EDWARD JENNER
(1749 - 1823)

English physician (doctor), and a pupil of **John Hunter**. Jenner was a pioneer of vaccination.

JAMES PRESCOTT JOULE
(1818 - 1889)

English physicist whose experiments with heat made it possible for others to construct the law of conservation of energy.

WILLIAM THOMSON KELVIN
(1824 - 1907)

Irish-born Scottish physicist whose many important contributions to physics included formulation of the law of conservation of energy. The Kelvin temperature scale is named after him.

JOHANNES KEPLER
(1571 - 1630)

German astronomer, physicist, and mathematician. He formulated three laws of planetary motion.

MUHAMMED IBN MUSA AL-KHWARIZMI
(c. 780 - 850)

Arab mathematician, geographer, and astronomer, influential in passing knowledge from Indian and Arab scholars to Europe.

GUSTAV ROBERT KIRCHHOFF
(1824 - 1887)

German physicist who, with **Robert Bunsen**, developed spectroscopy, which led to the discovery of several new elements.

ROBERT KOCH
(1843 - 1910)

German biologist who discovered the bacillus responsible for cholera and produced a vaccine against tuberculosis.

HANS ADOLF KREBS
(1900 - 1981)

German-born British biochemist, notable for working out the metabolic (energy) pathways in cells, known as the Krebs cycle.

JEAN-BAPTISTE LAMARCK
(1744 - 1829)

French evolutionary biologist whose work on the way species change over time paved the way for Darwin's theory of evolution.

PAUL LANGERHANS
(1847 - 1888)

German physician (doctor) remembered for his discovery of regions in the pancreas, called islets of Langerhans, which are now known to produce insulin.

ANTOINE LAVOISIER
(1743 - 1794)

French chemist often hailed as the father of chemistry. He discovered the role of oxygen in the process of combustion (burning) and the chemical composition of water.

KARL LANDSTEINER
(1868 - 1943)

Austrian-born American pathologist who discovered the four major blood groups (A, O, B, AB) in 1901 and the M and N blood groups in 1927.

LEE DE FOREST
(1873 - 1961)

American physicist and inventor, a pioneer of the technologies of radio and sound recording.

ANTONY VAN LEEUWENHOEK
(1632 - 1723)

Dutch microscopist who designed and used a powerful single-lens microscope. He was the first person to observe microorganisms, calling them animalcules.

GOTTFRIED WILHELM LEIBNIZ
(1646 - 1716)

German mathematician who was the first to publish work on a branch of algebra called calculus. He also originated the idea of a calculating machine.

GEORGES LEMAÎTRE
(1894 - 1966)

Belgian cosmologist and civil engineer who formulated the modern Big Bang theory of the origin of the universe.

LEONARDO DA VINCI
(1452 - 1519)

Italian artist, architect, engineer, and scientist. As an artist, he produced an impressive collection of anatomical studies.

CAROLUS LINNAEUS, ALSO KNOWN AS CARL VON LINNÉ
(1707 - 1778)

Swedish biologist who introduced the universal system of plant and animal classification, known as the binomial system.

HANS LIPPERSHEY
(1570 - 1619)

Dutch spectacle-maker credited with the invention of the telescope.

JOSEPH LISTER
(1827 - 1912)

English surgeon who improved the success rate in surgical operations by introducing antiseptics.

RICHARD LOWER
(1631 - 1691)

English physiologist who discovered, with **Robert Hooke**, that blood becomes bright red in the lungs - now known to be due to the oxygen that dissolves there.

MARCELLO MALPIGHI
(1628 - 1694)

Italian biologist and microscopist who discovered blood capillaries, giving weight to the system of blood circulation put forward by **William Harvey**.

BENOIT MANDELBROT
(BORN 1924)

Polish mathematician who is a central figure in the development of fractal geometry.

JAMES CLERK MAXWELL
(1831 - 1879)

Scottish mathematician whose most famous work was his theory of electromagnetic radiation, which he created by adapting **Faraday's** ideas of electric and magnetic fields.

GREGOR JOHANN MENDEL
(1822 - 1884)

Austrian monk and botanist, whose studies of the heredity patterns of plants laid foundations for the science of genetics. His work enabled a mechanism to be found for Darwin's evolution.

DMITRY MENDELEYEV
(1834 - 1907)

Russian chemist who constructed the first satisfactory periodic table of elements.

STANLEY LLOYD MILLER
(BORN 1930)

American chemist whose most famous work concerns the origin of life on Earth. In 1953, he produced some of the essential complex chemicals necessary for life.

JOHN MILNE
(1850 - 1915)

English seismologist who invented the modern seismograph and saw the importance of worldwide seismological stations.

FRIEDRICH MOHS
(1775 - 1859)

German geologist and mineralogist. The scale of mineral hardness that he devised bears his name.

MONDINO DE LUZZI
(c. 1270 - 1326)

Italian anatomist and physician who wrote the first book of anatomy since ancient times.

JOHN NAPIER
(1550 - 1617)

Scottish mathematician who was the inventor of logarithms, which allowed faster and more accurate calculation.

JOHN VON NEUMANN
(1903 - 1957)

Hungarian-born American mathematician, designer of some of the earliest electronic computers. His theoretical approach provided a model for the future development of electronic computers.

ISAAC NEWTON
(1642 - 1727)

English mathematician and physicist who is perhaps the most famous and influential scientist of all time. His achievements include a universal theory of gravitation, three laws of motion (called Newton's laws), and the first understanding that white light consists of a spectrum of colors.

HANS CHRISTIAN OERSTED
(1777 - 1851)

Danish physicist who discovered the magnetic effect of electric current. His discovery inspired the work of many experimenters, most notably **Michael Faraday**.

GEORG OHM
(1789 - 1854)

German physicist who developed a law (Ohm's Law) that relates flow of electric current to voltage. The unit of electrical resistance (the ohm) is named after him.

RICHARD DIXON OLDHAM
(1858 - 1836)

English geologist and seismologist whose studies of earthquake waves led him to realize the existence of the Earth's core.

PARACELSUS, ALSO KNOWN AS THEOPHRASTUS VON HOHENHEIM

(1493 - 1541)
German physician (doctor) who introduced the role of chemistry in medicine. He also made important discoveries about several diseases.

AMBROISE PARÉ

(c. 1510 - 1590)
French surgeon who is the father of modern surgery. He introduced ligatures (threads for binding blood vessels) into the treatment of surgical amputation.

BLAISE PASCAL

(1623 - 1662)
French mathematician and physicist who was the first to realize that the pressure in a fluid (liquid or gas) acts in all directions. This is known as Pascal's Principle.

LINUS CARL PAULING

(1901 - 1994)
American chemist who applied quantum theory to chemistry in order to understand bonding within molecules. He used X-ray diffraction techniques to figure out molecular structures. His belief in Vitamin C helped combat many non-nutritional diseases.

ARNO ALLAN PENZIAS

(BORN 1933)
American astrophysicist born in Germany who discovered, with Robert Wilson, the microwave cosmic background radiation by examining emissions from the Milky Way.

MAX KARL ERNST PLANCK

(1858 - 1947)
German theoretical physicist who was the first to suggest that energy is "quantized," which means it can only take certain values. This idea led to quantum theory that revolutionized science in the early 20th century.

JULES HENRI POINCARÉ

(1854 - 1912)
Prolific French mathematician whose important contributions to mathematics included the first steps in what is now called chaos theory. He also predicted some of the results of relativity a few years before Einstein.

JOSEPH PRIESTLEY

(1733 - 1804)
English experimental chemist who, in 1774, discovered oxygen (also discovered independently by Scheele). This discovery became known to Lavoisier, who then realized the importance of oxygen to burning.

JOSEPH LOUIS PROUST

(1754 - 1826)
French chemist who devised the law of constant proportions - Proust's Law. This states that the proportions of elements present in a compound is always the same.

PTOLEMY, ALSO KNOWN AS CLAUDIUS PTOLEMAEUS

(c. 150)
Alexandrian astronomer and geographer whose greatest work was *Almagest*, which consisted of thirteen books that listed constellations and presented the contemporary understanding of Greek astronomers. Ptolemy's idea that the Earth is at the center of the universe was challenged by Copernicus, Kepler, and Galileo.

PYTHAGORAS

(c. 580 - 500 BC)
Greek mathematician and philosopher who believed that everything is number. The theorem that bears his name was known long before his time.

CHARLES FRANCIS RICHTER

(1900 - 1985)
American seismologist who, together with Beno Gutenberg, devised the Richter scale for measuring the strength of earthquakes.

WILHELM KONRAD VON RÖNTGEN

(1845 - 1923)
German physicist who discovered X-rays in 1895. He also worked on the heat conductivity of crystals and the electromagnetic rotation of polarized light.

ERNEST RUTHERFORD

(1871 - 1937)
New Zealand-born British physicist who was the first person to identify the three types of radioactive emissions and to suggest the existence of the atomic nucleus.

JONAS SALK

(BORN 1914)
American microbiologist who developed the first effective vaccine for the disease poliomyelitis.

HORACE BÉNÉDICT DE SAUSSURE

(1740 - 1799)
Swiss physicist and geologist who coined the term "geology." Remembered for his invention of the first hygrometer.

CARL WILHELM SCHEELE

(1742 - 1786)
Swedish chemist who discovered oxygen independently of Joseph Priestley, and prepared several previously unknown acids.

EMILIO GINO SEGRÉ

(1905 - 1989)
Italian-born American physicist who found traces of the first artificial element (technetium) in a discarded cyclotron in 1937 and helped develop the atomic bomb.

CLAUDE ELWOOD SHANNON

(BORN 1916)
American mathematician who originated a branch of mathematics called information theory. He applied the logic theory of George Boole to electronic switches, aiding modern computer development.

ERNEST THOMAS SINTON WALTON

(1903 - 1995)
Irish nuclear physicist who built the first successful particle accelerator with John Cockcroft. They became the first scientists to "split the atom."

VESTO MELVIN SLIPHER

(1875 - 1969)
American astronomer whose observations of spiral galaxies gave the first evidence that the universe is expanding.

WILLIAM SMITH

(1769 - 1859)
English geologist who was the first person to make accurate geological maps.

SÖREN PETER SÖRENSEN

(1868 - 1959)
Danish chemist who invented the pH scale used for measuring the concentration of acids.

ERNEST HENRY STARLING

(1866 - 1927)
English physiologist who, with his colleague William Bayliss, identified the first known hormone, secretin, in 1902.

NIELS STENSEN, ALSO KNOWN AS NICOLAUS STENO

(1658 - 1686)
Danish scientist who carried out important work in a number of scientific fields. In geology, he is remembered for his ideas on sedimentary rocks.

FRITZ STRASSMAN

(1902 - 1980)
German physicist who, with Otto Hahn, discovered nuclear fission in 1938.

SUSHRUTA

(2ND CENTURY BC)
Indian surgeon who wrote extensively on all aspects of medicine known at the time.

THEOPHRASTUS

(c. 370 - 285 BC)
Greek philosopher, often called the father of botany, who was the first person to attempt a full classification of plants.

JOSEPH JOHN THOMSON

(1856 - 1940)
English physicist who discovered the electron in 1897 while investigating X-rays.

CLYDE WILLIAM TOMBAUGH

(BORN 1906)
American astronomer who discovered the planet Pluto in 1930. He also discovered several star clusters and galaxies.

EVANGELISTA TORRICELLI

(1608 - 1647)
Italian mathematician, physicist, and inventor of the mercury barometer. His most famous contribution, the idea of atmospheric pressure, was confirmed by Blaise Pascal.

ANDREAS VESALIUS

(1514 - 1564)
Italian founder of modern anatomy, one of the first to prove Galen's ideas wrong.

ALESSANDRO VOLTA

(1745 - 1827)
Italian physicist and inventor of the electric battery. His invention made possible the discoveries of Davy, Faraday, and many others.

JAMES DEWEY WATSON

(BORN 1928)
American molecular biologist who, with Francis Crick, figured out the molecular structure of DNA in 1953.

ALFRED WEGENER

(1880 - 1930)
German meteorologist and geophysicist, originator of the theory of continental drift (the Wegener hypothesis).

JOHN TUZO WILSON

(1908 - 1995)
Canadian geologist and geophysicist remembered for his work on plate tectonics.

FRIEDRICH WÖHLER

(1800 - 1882)
German chemist who transformed the study of organic chemistry in 1828 by producing an organic substance from inorganic reagents.

ROBERT WOODROW WILSON

(BORN 1936)
American astronomer who, with Arno Penzias, discovered cosmic background radiation - the best evidence yet for the Big Bang theory.

Glossary

A

ABDOMEN

The lower part of the trunk, which is separated from the chest by the **diaphragm**.

Contained in the abdomen are the organs of **digestion** and excretion and, in women, the uterus and **ovaries**.

ABSOLUTE MAGNITUDE

A measure of the **luminosity** of a celestial object. Absolute magnitude is taken to be the **apparent magnitude** an object would display if measured at a standard distance of 10 parsecs.

ABSOLUTE ZERO

The lowest possible **temperature**. Absolute zero is zero kelvin, -273.15° Celsius or -459.67° Fahrenheit.

ACCELERATION

A change in the **speed** of an object. A reduction in speed is a negative acceleration and is often called a deceleration. Acceleration is usually measured in ms^{-2} (meters per second per second, or meters per second squared).

ACCRETION DISK

A rotating, disk-shaped mass in space, which is formed by gravitational attraction.

ACHROMATIC DOUBLET

A system of two lenses that eliminates **chromatic aberration**. The two lenses are made of different types of glass.

ACID

A compound that contains hydrogen and can donate **protons** (hydrogen ions, H^+). In **aqueous solution**, the protons associate with water **molecules** to form hydronium ions, H_3O^+ .

ACTIVATION ENERGY

The least **energy** required for a particular **chemical reaction** to take place. Typically, it is supplied as heat energy; for

example striking a match produces heat to start the match **burning**.

ADDITIVE PROCESS

Combining light of different colors. When light of more than one color enters the eye, the resulting color is different from each of the initial colors.

ADHESIVE FORCES

The attractive **forces** between a liquid and its container, such as water and glass. The balance between adhesive and **cohesive forces** determines whether the **meniscus** of a liquid will be upward or downward.

AGAR

A seaweed extract that forms a gel on which liquid, bacteriological culture media can be solidified.

AIR RESISTANCE

A **force** acting on anything moving through the air, such as a falling object, which slows it down.

ALGAE

Unicellular or **multicellular**, chlorophyll-containing organisms that live in moist or aquatic **habitats**. Formerly thought to be plants, algae are now classified as members of the kingdom Protista.

ALKALI

A base that is soluble in water. When an alkali is dissolved, it produces hydroxide ions, OH^- .

ALKANE

A **hydrocarbon** in which the carbon **atoms** are joined only to each other or to atoms of other elements, with single bonds. An example is ethane.

ALKENE

A **hydrocarbon** that has one or more double bonds between its carbon **atoms**. An example is ethylene.

ALKYNE

A **hydrocarbon** that has one or more triple bonds between its carbon **atoms**. An example is ethylene.

ALLOTROPES

Forms of the same **element** with different crystalline structures. For example, diamond and graphite are allotropes of carbon.

ALLOY

A mixture of a metal with other metals or nonmetals, in specific proportions, prepared when they are molten. Bronze is an alloy of the metals copper and tin, while steel is an alloy of the metal iron and the nonmetal carbon.

ALPHA DECAY/ ALPHA PARTICLE

The breakup of an unstable atomic **nucleus**, resulting in the release of a **particle** consisting of two **protons** and two **neutrons** – an alpha particle. During alpha decay, the **atomic number** of the nucleus reduces by two and the **atomic mass** reduces by four. See **beta decay**.

ALTERNATING CURRENT (AC)

An **electric current** that reverses in magnitude and direction. Electricity power supply current is AC. Compare **direct current (DC)**.

ALTITUDE

Another word for height. In astronomy, it also refers to the angle of a celestial object above the horizon.

AMINO ACID

Any of a group of water-soluble **organic compounds** that have both a carboxyl ($-\text{COOH}$) and an amino ($-\text{NH}_2$) group joined to the same carbon **atom**. By forming peptide bonds, amino acids join together to form short

chains – peptides – or longer chains – polypeptides. One or more of these chains make up a **protein**. There are about 20 commonly occurring amino acids.

AMNIOCENTESIS

The withdrawal and sampling of the amniotic fluid, which surrounds the **embryo** in the **uterus**. The amniotic fluid contains **cells** from the embryo, which can be cultured and their chromosomal patterns studied in order to detect any chromosomal abnormalities, such as Down's syndrome.

AMORPHOUS SOLID

Any noncrystalline solid. The **particles** are not regularly arranged, so over time, they can flow. Amorphous solids are often called supercooled liquids or glass.

AMPLITUDE

The maximum value of a continuously varying quantity. For a water wave, the amplitude is the height of the wave – half the distance from peak to trough. For a sound wave, the amplitude determines how loud the sound will be.

ANABOLIC REACTION

Any **enzyme-mediated chemical reaction** that occurs inside a **cell** and results in the building of complex **compounds**, particularly **proteins**. Compare **catabolic reaction**.

ANAEROBICALLY

Without oxygen. Many animals respire anaerobically.

ANATOMICAL

Relating to anatomy, the study of the parts of a living **organism**.

ANGULAR MOMENTUM

The product of a spinning object's **speed** of rotation and its moment of inertia. An

object's moment of inertia is a measure of how hard it is to get the object spinning.

ANHYDROUS

Describing a substance that has lost its **water of crystallization**. Adding water rehydrates an anhydrous substance.

ANION

An **ion** with a negative **electric charge**, for example the fluoride ion, F^- , and the sulfate ion, SO_4^{2-} . Anions are attracted to the **anode** during **electrolysis**.

ANODE

The electrode in an **electrochemical cell** where **oxidation** occurs. The anode is the positive terminal in an electrolytic cell, but negative in a voltaic cell.

ANTENNA

(Life Sciences and Ecology) Long, jointed, paired appendages on the head of many **arthropods**. They usually facilitate smell or touch.

ANTENNA

(Electronics) Another word for an aerial, which receives or transmits **radio waves**.

ANTERIOR

Relating to the front of an **organism**. The opposite of posterior.

ANTHER

The upper, double-lobed part of a plant **stamen**. A **pollen** sac is contained in each lobe. Inside the pollen sacs are pollen grains, which are released when the anther ruptures.

ANTIBIOTIC

A substance obtained from **microorganisms** that destroys or inhibits the growth of certain other microorganisms, particularly **disease-producing bacteria** and fungi. Common antibiotics include penicillin and streptomycin.

ANTIBODY

A **protein** that is made by certain white blood cells (lymphocytes), in the body, in response to the invasion of a foreign substance (**antigen**) such as **bacteria**, inhaled pollen grains and dust, and foreign tissue grafts.

ANTIGEN

Any substance that the body considers to be foreign and which therefore triggers an immune response.

ANTIPARTICLE

A **particle** that has the same **mass** as another particle, but has an opposite **charge** or some other opposite property.

APHELION

The farthest point from the Sun in the **orbit** of any planet, comet, or artificial satellite.

APPARENT MAGNITUDE

A measure of how bright a celestial object appears in the sky. The brighter an object, the lower its magnitude. Compare **absolute magnitude**.

AQUEOUS SOLUTION

A solution in which the **solvent** is water.

ARTICULATED

Describing two bones connected by a **joint**.

ARTHROPOD

Any member of Arthropoda, the largest **phylum** in animal classification. All arthropods have jointed legs and segmented bodies. Spiders, crabs, and houseflies are all arthropods.

ASEXUAL REPRODUCTION

Production of offspring that are **genetically** identical to the parent. This form of reproduction takes place without the formation of **gametes**.

ASTRONOMICAL UNIT

The average distance between the Sun and the Earth. An astronomical unit equals 149,597,870 km (499 light seconds).

ATMOSPHERE

A layer of gases that surround a planet or moon. On some planets and most moons, the **gravitational** force is not strong enough to retain an atmosphere. The Earth's atmosphere supports life and protects it from certain **radiation**; it also prevents the planet from massive fluctuations in **temperature**. See **greenhouse effect**, **atmospheric pressure**.

ATMOSPHERIC PRESSURE

The standard **pressure** of the Earth's **atmosphere** at sea level, equal to about $101\,000\text{ Nm}^{-2}$ (101 000 pascals), or 760 mmHg (millimeters of mercury). This pressure is also equal to 1 atm (atmosphere).

ATOM

The smallest part of an **element** that retains its chemical identity. Atoms are electrically neutral. They consist of negatively charged **electrons** that surround a central, positively charged **nucleus**.

ATOMIC FORCE MICROSCOPE

A device used to produce images of **atoms**. A probe scans a solid surface, closely following the contours of its atoms. A computer converts the probe's motion into an image of the surface atoms.

ATOMIC MASS

The total **mass** of **protons** and **neutrons** in the **nucleus** of an **atom**, expressed in atomic mass units. Fluorine-19, with nine protons and ten neutrons, has an atomic mass of 19. Also known as relative atomic mass (**RAM**).

ATOMIC NUCLEUS

See **nucleus**.

ATOMIC NUMBER

The number of **protons** present in the **nucleus** of an **atom**.

ATP

Abbreviation for "adenosine triphosphate," the name of a chemical used as a carrier of **chemical energy** in the cells of all living things.

AUTOTROPH

Literally means "self-feeding." Any **organism** that produces food, normally by **photosynthesis**, is an autotroph. Compare heterotroph.

AXIAL TILT

The angle between the axis of a planet and the ecliptic plane.

AXIS

An imaginary line about which an object is symmetrical or about which it spins. In astronomy, axis is taken as axis of rotation, the line (north-south) about which plan a planet rotates.

B

BACTERIUM

Unicellular organism of the kingdom Protista. A bacterial cell lacks a membrane, but has a nucleus and a cell wall. Some bacteria are disease-causing parasites.

BASE

(Chemistry) A compound that can accept protons (hydrogen ions, H⁺) to neutralize acids and produce a salt and water.

BASE

(Life Sciences and Ecology) Any of the four nitrogen-containing organic compounds that link to the sugar phosphate chain in DNA. Bases are the fundamental units of the genetic code.

**BETA DECAY/
BETA PARTICLE**

The breakup of an unstable atomic nucleus, resulting in the release of a fast-moving electron. This electron is called a beta particle. During beta decay, the atomic number of the nucleus increases by one. This is because a neutron changes into a proton, releasing the electron, the atomic mass is unchanged. See alpha decay.

BILE

Also known as gall. A greenish, bitter-tasting fluid produced in the liver. It helps to digest fats.

BINARY

The number system based on the number two. It has only two digits (binary digits, or bits), "0" and "1". Binary is well suited to arithmetic and logical operations in computers. Inside a computer, binary digits are represented by electric pulses that may be "off" or "on". See binary addition.

BINARY ADDITION

Addition in base 2 (binary). The rules governing binary addition are the same as those for addition in base 10, except that the binary system uses only two digits, "0" and "1". In binary, $0 + 1 = 1$ and $1 + 1 = 10$ (number 2 in binary).

BIOCHEMICALS

A term generally used to encompass those organic compounds directly involved in vital processes within a living organism, such as DNA and enzymes.

BIODIVERSITY

A measure of the total number or variety of species, in a particular area. Rainforests, for example, have high biodiversity.

BIOSPHERE

The name given to the total area of the Earth's surface (including the seas) that is inhabited by living things.

BLOOD

A fluid tissue, which has many vital functions within animals, especially the transport of oxygen and food for respiration.

BLOOD CAPILLARY

The smallest type of blood vessel, which forms a link between arteries and veins.

BLOOD VESSEL

Any of the tubes of the vascular system in an animal. In humans, arteries carry blood from the heart, and veins carry blood to the heart.

BROWNIAN MOTION

The random motion of small solid objects, such as smoke particles, which can be observed under a microscope. It is caused by atoms and molecules of liquid or gas bombarding the solid objects.

BUBBLE CHAMBER

A device used to detect subatomic particles in collisions that take place in particle accelerators.

BURNING

The rapid combination of a substance with oxygen; it is an exothermic reaction. Also called combustion.

C

CESARIAN SECTION

A surgical operation which is carried out to remove a fetus (unborn young) from a uterus.

CALCAREOUS

Consisting of or containing calcium carbonate. In anatomy, the term is applied to any buildup of the compound in the body.

CALCIUM

A chemical element that is found in bones. It is a metallic element in group 2 of the periodic table.

CANOPY

The highest layer of a forest, formed by the branches of the tallest trees. Leaves in the canopy receive the most sunlight and are, therefore, the most successful photosynthesizers.

CAPACITANCE

A measure of the capability of an object to store electric charge. It is measured in farads (F).

CAPILLARY ACTION

The rising or falling of a liquid in a narrow tube, above or below the liquid surface, due to surface tension. The narrower the tube, the higher the liquid will rise or fall.

CARBOHYDRATE

An organic compound, such as a sugar, that only contains the elements carbon, hydrogen, and oxygen.

CARBON DIOXIDE

A compound with the formula CO₂ and a gas at room temperature. It is a waste product of respiration and one of the reactants of photosynthesis.

CARNIVOROUS

An animal that primarily eats meat. A few plants are described as carnivorous, although they only supplement their diet with insects. Compare omnivorous and herbivorous.

CARPEL

The female reproductive structure of a flower, typically consisting of stigma, style, and ovary.

CARTILAGINOUS

Fish of the class Elasmobranchii, whose skeleton is made from cartilage, a material common to all vertebrates. Cartilage forms the skeleton of vertebrate embryos and is replaced by bone as the young grow and mature.

CATABOLIC REACTION

Any enzyme-mediated reaction within a cell that results in the breakdown of complex compounds, with large molecules, into simpler chemicals, with smaller molecules. Compare anabolic reaction.

CATALYST

A substance that increases the rate of a chemical reaction but is itself unchanged at the end of the reaction. An enzyme is a biological catalyst.

CATARACT

A clouding of the lens of the eye, which usually occurs during old age.

CATHODE

The electrode in an electrochemical cell where reduction occurs. The cathode is the negative terminal in an electrolytic cell but the positive one in a voltaic cell.

CATHODE-RAY TUBE

A sealed glass tube used in the display of most televisions. Inside the tube, electrons leave a cathode and are attracted toward the high-voltage anode. The electrons form a beam, sometimes called a cathode ray.

CATION

An ion with a positive electric charge. Metals readily form cations, such as the copper(II) ion, Cu²⁺. Cations are attracted to the cathode during electrolysis.

CELL
(Life Sciences and Ecology)
The basic unit of all living things. Prokaryotic cells do not have a distinct **nucleus**, whereas eukaryotic cells do. All plants and animals consist of **tissues**, which consist of eukaryotic cells.

CELL
(Chemistry) See **electrochemical cell**.

CELSIUS
A **temperature** scale on which water freezes at zero degrees and boils at 100 degrees. Each degree Celsius is equal to one degree **kelvin**. The Celsius scale was once called the Centigrade scale but was renamed in 1948.

CENTRAL NERVOUS SYSTEM
See **nervous system**.

CENTER OF GRAVITY
The point of an object at which clockwise and counter clockwise moments are equal and the object is, therefore, balanced.

CENTRIPETAL FORCE
The **force** needed to keep an object moving in a circle or an **ellipse**. In the case of circular motion, the force is always directed to the center of the circle.

CERN (CONSEIL EUROPEEN POUR LA RECHERCHE NUCLEAIRE)
The European Laboratory for Nuclear Physics based near Geneva on the Swiss-French border and run by 19 European nations.

CFC
Abbreviation for chlorofluorocarbon. Any **compound** formed by replacing some or all of the **hydrogen atoms** of a **hydrocarbon** with chlorine and fluorine atoms. CFCs released in the **atmosphere** attack the ozone layer.

CHAIN REACTION
A process, such as nuclear **fission**, in which each reaction is, in turn, the stimulus for a further reaction.

CHARGE
See **electric charge**.

CHEMICAL REACTION
A process in which **elements** or **compounds** (the reactants) change to form different elements or compounds (the **products**). The change may be permanent or reversible. During a chemical reaction, **electrons** are transferred or shared between the reactants.

CHITIN
A complex **carbohydrate**, similar to cellulose, that strengthens the bodies of **invertebrates**.

CHLOROPLAST
An **organelle** found in plant cells that undergoes **photosynthesis**. Chloroplasts contain the pigment chlorophyll.

CHOLESTEROL PLAQUE
A thickening of the arteries, which is caused by a buildup of cholesterol; it is a major cause of heart disease. Cholesterol plaque is also called atherosclerotic plaque.

CHROMATIC ABERRATION
A defect in a lens, caused by different wavelengths of light being refracted by different amounts as they pass through glass. The image produced by the lens has colored fringes around it. The problem can be solved by using an **achromatic doublet**.

CHROMATOGRAPHY
A technique used to separate a mixture. The various types of chromatography all use a substance, called the stationary phase, that takes up different parts of the mixture at different rates.

CHROMOSOME
A structure found in plant and animal cells, consisting of chromatin, which in turn consists largely of **DNA**. All of the **genes** of an **organism** are found in its chromosomes. Humans have 23 pairs of chromosomes in each cell (except gametes).

CIRCULATORY SYSTEM
The heart, **blood vessels**, blood, lymph, and lymphatic vessels, which transport substances around the body.

CLINICAL
Relating to the direct observation and treatment of a patient.

CLOUD CHAMBER
A device used to detect and track **particles** resulting from **radioactive decay**. **Alpha** and **beta particles** cause a vapor in the chamber to condense around them, making their tracks visible.

COHESIVE FORCES
The attractive forces between **atoms** or **molecules** in a liquid, such as water. Cohesive forces are responsible for **surface tension**.

COLLOID
A type of mixture, similar to a **solution**, in which **particles** of one substance are distributed evenly throughout another. Colloidal particles are larger than those in a solution but smaller than those in a **suspension**.

COMPLEX ION
A type of **ion** in which a central metallic **cation** is combined with surrounding **anions** or **molecules**. Iron and other transition metals form complex ions with water molecules.

COMPLEX NUMBER
A type of number, generally $a + ib$, consisting of a real part (a) and an imaginary part (ib). The real part is a real number, while the imaginary part is a

multiple of the square root of -1 , written i . An example of a complex number is $7 + 4i$.

COMPONENT
The effect of a **force** in a particular direction. A force can be thought of as a combination of two or more components.

COMPOUND
A pure substance in which **elements** are chemically combined in a definite ratio. In the compound water, H_2O , **atoms** of hydrogen and oxygen are bound together in the ratio 2:1. Compounds with **covalent bonding** generally consist of **molecules**.

COMPOUND EYE
The eye of an insect, consisting of many, individual visual units.

COMPRESSION
The action of squashing a substance so that it takes up a smaller space. When a gas is compressed, its **pressure** increases. When a solid is compressed, **reaction forces** are produced. These forces are responsible for the strength of a solid.

CONCAVE
Shaped like the inside of a bowl. Concave mirrors make parallel light rays converge. Concave lenses make parallel light rays diverge.

CONCENTRATION
The amount of a dissolved substance (solute) present in unit volume of **solution**. Molar concentration has units of moles per liter (mol l^{-1} or mol dm^{-3}). The units of mass concentration are kilograms per liter (kg l^{-1} or kg dm^{-3}).

CONDUCTIVE
Describes a material that allows **electric current** to flow through it easily. A material with a high conductivity allows electricity to flow easily and is called a conductor. The term can be used to describe heat flow, as well as the flow of electricity.

CONE

(Human Anatomy) A type of cell at the back of the human eye (the retina), which is sensitive to light in a particular color range. The cones allow for color vision. There are three types of cone cells: red-, green-, and blue-sensitive.

CONE

(Life Sciences and Ecology) A reproductive structure that is common to all gymnosperms, such as pines and ferns.

CONE

(Mathematics) A solid (three-dimensional) figure with a circular or elliptical base and an apex (point).

CONSTANT

A term in an algebraic equation that does not change its value. Compare **variable**.

CONSTRUCTIVE INTERFERENCE:

The combination of two waves where the waves are "in step" – the peaks of one wave correspond to the peaks of the other.

CONVECTION

A process by which heat is transferred within a fluid (liquid or gas), by the movement of the fluid. For example, hot air rises and is replaced by cold air; this is an important factor in determining weather patterns.

CONVERGE

To come together. For example, parallel light rays come together when they come to a point of focus.

CONVEX

Shaped like the outside of a bowl, when it is turned upside down. Convex lenses make parallel light rays converge. Convex mirrors make parallel light rays diverge.

COSMIC BACKGROUND RADIATION (CBR)

Electromagnetic radiation in the microwave region of the spectrum that emanates from every region of space. Also known as **microwave background radiation**. It is the strongest evidence of the Big Bang.

COTYLEDON

Part of a plant embryo that either stores food or grows to become the first leaves to undergo photosynthesis. Flowering plants are classified as **monocotyledons** or **dicotyledons**, according to whether they possess one or two cotyledons.

COVALENT BONDING

A type of chemical bonding in which electrons are shared between the atoms involved. Compounds that exhibit this type of bonding are called covalent compounds.

CRITICAL ANGLE

The angle at or above which light, striking the boundary between two different materials, undergoes total internal reflection.

CRUSTACEAN

Any member of the class Crustacea. This class consists of mainly marine or freshwater **arthropods**, such as crabs.

CRYOGENIC UNIT

Device used to reduce the temperature of substances to very low values, often only a few degrees above absolute zero.

CRYSTAL

A regular arrangement of atoms, ions, or molecules in a solid. This regular internal structure leads to a geometrically regular external shape. Sodium chloride crystals, for example, are cubic.

CRYSTAL LATTICE

A regular, repeating arrangement of atoms or molecules in a solid. See **unit cell**.

CURRENT

See **electric current**.

CYTOPLASM

A jellylike material that surrounds the nucleus of a cell and contains most of the cell's organelles.

D**DECOMPOSITION**

Any chemical reaction in which a compound breaks down into simpler compounds or elements. Many compounds decompose upon heating or electrolysis.

DEEP MUSCLE

Any large muscle that is situated deep under the skin. Deep muscles in the back are responsible for rotation, extension, and flexion of the spine.

DEHYDRATING AGENT

Removes water from another substance in a chemical reaction called dehydration. Some dehydrating agents can remove hydrogen and oxygen in the ratio 2:1 to make water where there was none before.

DENSITY

A measure of the concentration of mass in a substance. The numerical value for density is calculated by dividing the mass of a given amount of the substance by its volume.

DENTITION

The type, number, and arrangement of teeth in an animal.

DESTRUCTIVE INTERFERENCE

The combination of two waves where the waves are "out of step." This means that the peaks of one wave correspond to the troughs of the other.

DIAGNOSIS

The act of identifying a disease or any other medical condition, by its symptoms.

DIAPHRAGM

A powerful muscle, which is essential to breathing, located in the abdomen of the mammal. When it contracts, the diaphragm causes the lungs to expand, drawing in air.

DIATOMIC

Relating to a molecule that is made up of two atoms, for example hydrogen.

DICOTYLEDON (DICOT)

See **cotyledon**.

DIELECTRIC

Any material between the plates of a capacitor (electronic component); normally chosen to increase the **capacitance** of the capacitor.

DIFFRACTION

The bending of waves around the edge of an object. When the rays pass through a narrow gap, they bend outward from the edges of the gap so that the light spreads out.

DIFFRACTION GRATING

A device for producing spectra, normally of visible light. The most common type of grating consists of a glass plate ruled with thousands of lines.

DIFFUSION

The mixing of substances, caused by the random motion of their particles. Diffusion is most noticeable in gases, because the movement of the particles is much faster than in liquids or solids.

DIGESTION

The process by which the large, complex molecules in food are broken down into simpler compounds that can be used by the body in activities such as **respiration**.

DIRECT CURRENT

An electric current that does not change direction, although its magnitude may vary. Compare **alternating current**.

DISEASE

Any impairment of the vital functions of an organism, often caused by a virus or a parasitic bacterium. Diseases can also be caused by a deficiency of substances, such as vitamins.

DISPLACEMENT

A movement away from, or the distance of an object from its normal position.

DISPLACEMENT REACTION

A chemical reaction in which one atom, ion, or molecule replaces another. Zinc displaces copper from a solution of copper(II) ions, Cu^{2+} .

DISTILLATION

Boiling a liquid to vaporize it and then condensing the vapor back into a liquid in a separate vessel. Distillation is used to separate the solute from the solvent in a solution. A mixture of liquids with different boiling points is separated out by fractional distillation.

DIVERGE

To move apart, as parallel light rays do when they pass through a concave lens.

DIVISION

The level below kingdom in the classification of plants. The names of all the divisions end in -phyta, for example Bryophyta.

DNA

Deoxyribonucleic acid. A complex molecule with the shape of a double-stranded helix. DNA is found in most living organisms and carries the hereditary information that is used in the synthesis (formation) of proteins. Compare RNA.

DOMAIN

Tiny magnetized regions, between 0.1 and 1 mm across, which occur within magnetic materials. In an unmagnetized state, the domains cancel each other out. When a material is magnetized, the domains are made to line up with each other.

DOUBLE DECOMPOSITION

A chemical reaction between two salts in which ions or radicals are exchanged, usually in solution.

E**ECCENTRIC**

Describing an orbit that is not circular. The difference between **aphelion** and **perihelion** is greater for planets with eccentric orbits.

ECHOLOCATION

A method used by some animals to locate objects. It involves the detection of echoes of pulsed sound that are produced by the animals themselves.

ECLIPTIC PLANE

The plane of the Earth's orbit. On the celestial sphere, the ecliptic plane appears as the path followed annually by the Sun in the sky.

ECTOTHERMIC

Relating to an animal that derives its body heat from external sources; reptiles are ectothermic.

ECOSYSTEM

A community of organisms and their physical surroundings.

EFFLORESCENT

Describing a substance that loses some or all of its water of crystallization to the air, forming a new, often powdery substance. If all the water is lost, the anhydrous form results.

ELASTICITY

The ability of a substance to regain its size and shape after being stretched by forces of tension. Forces of attraction between atoms within the substance are made stronger when the atoms are pulled apart. These forces are responsible for elasticity.

ELECTRIC CHARGE

A property of certain particles or substances that results in electrostatic forces. There are two types or signs of charges - positive and negative. The numbers of positive and negative charges in matter is normally balanced, giving no overall charge. See **ion**.

ELECTRIC CURRENT

The movement of particles with electric charge. Most electric currents are the result of moving electrons. The movement of electrons is caused by electrostatic or electromagnetic forces.

ELECTRIC FIELD

A region in which a particle with electric charge will experience an electrostatic force.

ELECTROCHEMICAL CELL

A system that consists of an electrolyte, two electrodes (a cathode and an anode), and an external electric circuit. There are two basic types of electrochemical cells: the electrolytic cell, used in electrolysis and electroplating, and the voltaic cell, found in household batteries.

ELECTRODE

A plate made from an electrical conductor, sometimes graphite but usually metal, that is used in electrochemical cells. In a cell, one electrode is the anode, the other is the cathode.

ELECTROLYSIS

A process in which a chemical reaction occurs as a result of an electric current being passed through an electrolyte. Decomposition of compounds can be achieved by electrolysis.

ELECTROLYTE

A paste, liquid, or solution containing ions that conducts an electric current. The current is carried by electrically charged ions, which move toward the oppositely charged electrode. Sodium chloride solution and molten sodium chloride are both electrolytes.

ELECTROMAGNET

A device made by winding a continuous coil of wire around an iron core. Electric current flowing through the wire creates magnetism that lines up the domains in the iron. This turns the iron into a temporary magnet.

ELECTROMAGNETIC FORCE

The forces on electric charges moving in a magnetic field. The size and direction of the force depends upon the speed, sign, and size of the charge, and on the strength and direction of the magnetic field.

ELECTROMAGNETIC RADIATION

A form of energy that travels through space and matter. It is associated with electric fields and magnetic fields, and behaves as a wave motion involving these fields. It also behaves as a stream of particles called photons. The many types of radiation include light waves, radio waves, and X rays.

ELECTROMAGNETIC SPECTRUM

The range of electromagnetic radiation. Each type of radiation is identical except for its wavelength and its energy. Radiation types with short wavelengths and high energy include X rays and gamma rays, while longer-wavelength and lower energy radiation includes infrared and radio waves.

ELECTROMOTIVE FORCE

The force on a particle with electric charge. In an electric circuit, the emf is supplied by a battery or by a power pack connected to mains electricity.

ELECTRON

A particle carrying a negative electric charge that is found in all atoms. In a neutral atom, there are equal numbers of protons and electrons.

ELECTRON SHELL

A set of orbitals in an atom, where electrons may be found. The first shell, closest to the nucleus, holds up to two electrons in an s-orbital. The second shell has one s- and three p-orbitals, holding up to eight electrons, while the third shell, which also has five d-orbitals, can hold up to 18.

Usually shells are filled progressively from the first shell outward. Across a period, from group 1 through group 18, empty orbitals up to the current shell are filled. Moving from a group 18 element to the next (group 1) element, a new shell is begun.

ELECTROPLATING

A process in which metal cations from an electrolyte are deposited as a thin layer onto the surface of a metal object that has been used as the cathode. Many items, from spoons to car bodies, are electroplated.

ELECTROSCOPE

An instrument for measuring the extent of imbalanced electric charge in an object. The most common example is a glass box with two pieces of gold foil that are pushed apart as they are charged by induction.

ELECTROSTATIC FORCE

The forces between electric charges. Two charges of the same sign will push apart, or repel. Charges of different signs pull together, or attract.

ELEMENT

A substance containing atoms with the same atomic number. Every element has characteristic chemical properties. There are 91 naturally occurring elements on Earth.

ELLIPSE

A shape that looks like a flattened circle. The orbits of the planets are ellipses.

EMBRYO

An animal before it has hatched or been born. A human embryo is called a fetus after eight weeks of pregnancy. An embryo is also the structure in many plants that develops from the zygote and becomes a new plant.

EMPIRICAL

Describing a result or formula that is gained directly from observation or experiment.

ENDOTHERMIC

Describing a chemical reaction during which heat energy is taken in from the surroundings and converted into chemical energy.

ENERGY

The ability to make something happen. Energy must be expended in order to do work. Although the total amount of energy in the universe is constant, it can take many interchangeable forms. The two basic forms of energy are potential energy and kinetic energy.

ENVIRONMENT

The surroundings in which an organism live, and its chemical, physical, and biological conditions.

ENZYME

A catalyst that is found in, or derived from, a living organism. Enzymes increase the rate of chemical reactions and are highly specific, usually catalyzing a particular step in a long and complex chain of reactions. Nearly all enzymes are proteins.

EQUATOR

An imaginary line around the middle of the Earth, at equal distances from the two (geographical) poles. Other planets and the Sun also have equators. The Earth's equator is at latitude 0°.

EQUILIBRIUM

A stable state in a reversible chemical reaction. Such a reaction can be thought of as two simultaneous reactions (the forward and reverse reactions). The reactions are in equilibrium when they proceed at the same rate, so there is no overall change.

ERECTILE

Biological tissue that has the ability to become rigid. The penis consists largely of erectile tissue, which stiffens when blood is temporarily trapped inside it.

ERROR BAR

A vertical or horizontal line drawn on a graph to indicate the margin of accuracy with which a particular measurement is taken.

EROSION

Any process by which landforms are worn away. Agents of erosion include rivers, ocean waves, and glaciers.

EUKARYOTE

Any organism with cells that have their genetic material contained within a nucleus.

EVAPORATION

The loss of atoms or molecules from a liquid as they break free of the liquid to become a vapor. Evaporation takes place below the boiling temperature of the liquid.

EVOLUTION

The gradual process that gives rise to new species through adaptation to the environment. The adaptation of species to their environment takes place by natural selection.

EXCITED

In possession of extra energy. Electrons in atoms can be excited by heat or light energy. When this is so, they occupy a new position in the atom, depending on their new energy.

EXOTHERMIC

A chemical reaction during which chemical energy of the reactants is converted to heat energy and given off to the surroundings. Exothermic reactions are generally accompanied by a rise in temperature.

EXTENSOR

Any muscle that straightens or extends a joint. Compare flexor.

EXTINCT

A species whose population has declined to zero.

F

FACIAL MUSCLE

Any of the **superficial muscles** of the face. Facial muscles are controlled by certain pairs of the cranial nerves.

FAHRENHEIT

Scale of **temperature** on which water freezes at 32 degrees and boils at 212 degrees.

FAST-ACTING DRUG

A drug that is administered directly into the bloodstream.

FERTILIZATION

The process by which the **nuclei** of male and female **gamete** cells join, or fuse.

FIBROBLAST

A cell that produces fibers in connective **tissue**.

FILAMENT

(Physics) The fine wire in an incandescent light bulb. The filament heats up when **electric current** flows through it and at high **temperatures** it glows.

FILAMENT

(Life Sciences and Ecology) The stalk of the **stamen** within a flower.

FILTRATION

A method for separating **suspensions**. The suspension is passed through a filter, often made of paper, which is perforated by tiny holes.

FIRST AID

Emergency medical care that is administered by the first person to arrive at the scene of an accident.

FISSION

(Physics) The splitting of unstable **nuclei** of **atoms**. It may result in a **chain reaction**.

FISSION

(Life Sciences and Ecology) **Asexual reproduction** of some single-celled **organisms**, during which the single parent cell splits to form two or more daughter cells.

FLEXOR

Any muscle that bends or flexes a **joint**. Compare **extensor**.

FLUID

Any substance that flows. Liquids and gases are both fluids.

FLUORESCENCE

A type of **luminescence** in which a substance glows with visible light immediately after being **excited** by invisible **ultraviolet radiation**.

FOCAL LENGTH

The distance from a lens or curved mirror at which a parallel beam of light becomes focused.

FOOD WEB

A set of interrelationships between **organisms** in an **ecosystem**.

FORCE

A push or a pull that can cause an object to speed up, slow down, or change direction.

FOSSIL

Traces of ancient plants or animals that are preserved in geological formations, in particular **sedimentary rocks**.

FOSSIL FUEL

Coal, oil, or natural gas. These substances were formed from the remains of ancient plants or animals. See **fossil**.

FRAME OF REFERENCE

In relativity theory, a particular set of Cartesian axes, with its origin centered about the observer. Observers moving relative to each other have different frames of reference.

FREQUENCY

The regularity with which something happens. It is most often applied to a wave or vibration. A wave's frequency is the number of times its complete cycle occurs each second. Frequency is measured in hertz (Hz).

Higher-frequency vibrations produce higher-pitched sounds.

FULCRUM

The point about which an object turns. For example, the fulcrum of a lever is its pivot.

FUNCTION

A mathematical relationship between two or more **variables**. It may be expressed by an algebraic equation. $y = 2x$ is an example of a function involving the variables y and x .

FUSION

A joining of small **nuclei** of **atoms** to form larger nuclei. In some cases there is a release of **energy** during the process.

G

GAMETE

A sex **cell**, which may be male or female, found in an animal or plant that reproduces sexually.

GAMMA RAYS

Electromagnetic radiation with a **wavelength** of 10^{-10} to 10^{-14} m. Gamma rays are normally released during a **nuclear reaction**.

GAS

One of the states of matter, in which the **particles** (**atoms** or **molecules**) are practically free from one another.

GAS GIANT

A planet that is composed mainly of gases (methane and ammonia are most common). Compare **terrestrial planet**.

GAUGE BOSON

A **particle** exchanged between two interacting **particles**. At the submicroscopic level of the tiniest particles, the exchange is responsible for producing forces.

GEIGER-MULLER TUBE

A device for detecting **radioactivity**. When **alpha** or **beta particles** enter, an **electric current** flows between the wall of the tube and a metal wire at its center.

GENE

The unit of inheritance. Genes are composed of lengths of **DNA** and each length holds the **genetic code** for a single **protein**.

GENERATOR

A machine that produces an electrical **voltage** whenever its rotor is turned. The **kinetic energy** of the rotor becomes electrical energy because of the presence of coils and magnets.

GENETIC CODE

The means by which genetic information is coded in **DNA**. The information is held as a sequence of **DNA bases**.

GENETIC DISORDER

A disease caused by a mutation (usually inherited) in the **genetic code**.

GENETIC VARIATION

The difference between individual **organisms** within a particular species. Genetic variation is normally inherited and is due to differences in the **genotype** between individuals of the same species, for example eye color in humans.

GENOME

All the **genes** held on a single set of **chromosomes**. In sexual reproduction, each parent gives its genome to the offspring.

GENOTYPE

The entire **genetic code** of an **organism**, which is held on all the **chromosomes**.

GERM

Any **microorganism** that causes **disease**.

GILL

The part of a fish (and certain amphibians) that is involved in **respiration**. Oxygen and carbon dioxide is exchanged (between the water and the animal's blood supply) in the gills.

GLAND

A group of cells, in plants or animals, that releases particular substances. An example is the thyroid gland, which releases two **hormones** into the **circulatory system**.

GLUON

According to modern scientific theory, gluons are the **particles** responsible for carrying the **strong nuclear force**. See **gauge boson**.

GRAPH

A visual representation showing a set of results of an experiment. A graph will highlight any relationships between the various types of data.

GRAVITATION

See **gravity**.

GRAVITY

A force of attraction between all objects with **mass**. The size of the force depends upon the masses of the two objects and the distance between the objects. Some modern theorists believe that **gravity** is carried by particles known as gravitons. See **gauge boson**.

GREENHOUSE EFFECT

The mechanism that results in global warming. **Ultraviolet** and visible light pass easily through the **atmosphere**, but are re-radiated as **infrared**, which is absorbed by "greenhouse gases," such as carbon dioxide. Because the radiation cannot pass through the **atmosphere**, the **temperature** of the Earth is gradually increasing.

GROUNDWATER

Any water below ground, either held in the soil or in underground lakes and caves.

GYROSCOPE

Usually a spinning metal disk supported in a metal cage, although it can also refer to any spinning object. Gyroscopes have stability because they spin.

H**HABITAT**

The place where an **organism** lives. An earthworm's habitat is the soil.

HADRON

Any **particle** that is composed of **quarks**. Examples are the **proton** and the **pi meson**.

HERBIVOROUS

Relating to animals that primarily eat vegetation. Compare **carnivorous** and **omnivorous**.

HETEROTROPH

Any **organism** that derives its energy from the intake and digestion of plants or animals. All animals are heterotrophs. Compare **autotroph**.

HIGGS BOSON

Hypothetical **particle** whose existence would link together the **electromagnetic force** and the weak interaction, explaining why particles have **mass**.

HIGH-FREQUENCY SOUND WAVE

See **Frequency**.

HOLE

A vacant **electron** position within the crystal lattice of a **semiconductor** that can be thought of as a positive **electric charge**.

HORMONE

A **chemical compound** secreted by a **gland** in the body that regulates growth or the function of an **organ**. Examples of this are insulin and follicle stimulating hormone. Hormones also promote growth in plants.

HOST

In a **parasitic** relationship between two species, the host is the **organism** that provides shelter or nutrition for another organism.

HUMAN CHORIONIC GONADOTROPHIN (HCG)

A **hormone** secreted by a human **embryo** and later by the

placenta. Urine-based pregnancy tests display a positive result if they detect hCG.

HYBRIDIZATION

The formation of new bonding **orbitals** from the combination of two others. For example, diamond consists of carbon **atoms** joined to four others by sp^3 hybrid orbitals, each one a combination of an s - and a p -orbital.

HYDROCARBON

A **compound** containing only the **elements** carbon and hydrogen. Hydrocarbons are classed as **organic compounds**.

HYDROGEN BONDING

Weak bonding between some **molecules** that contain hydrogen **atoms**. It is caused by the uneven distribution of **electric charge** within the molecules. Hydrogen bonding is found in water and is responsible for its relatively high boiling point.

HYDRONIUM ION

Also called a hydroxonium or oxonium ion. This is an **ion** with formula H_3O^+ , which consists of a **proton** or hydrogen ion, H^+ , associated with a water **molecule**, H_2O . Hydronium ions form in equal numbers with hydroxide ions, OH^- , when water splits into ions. In a **solution** of an **acid**, the concentration of H_3O^+ is higher than that of OH^- .

HYDROSTATIC SKELETON

The part of certain animals, such as earthworms, that is held rigid by fluid pressure.

HYGROSCOPIC

Describing a substance that absorbs water from the air.

HYPOTHALAMUS

A part of the brain (situated near the center, below the thalamus) that controls several basic body functions, including **temperature regulation**.

IJK

IGNEOUS ROCKS

One of the three main types of rocks, together with **sedimentary** and **metamorphic**. Igneous rocks form from **magma** that solidifies. Granite is an example of an igneous rock.

IMAGE

A picture formed by a lens or a curved mirror. Images cast on screens by **convex** lenses are called real images, while those seen through telescopes or microscopes, which cannot be directly projected, are called virtual images.

IMMUNOLOGICAL REACTION

The production of **antibodies** when the body is infected by foreign substances. During **vaccination**, foreign disease-causing substances, such as **antigens**, cause an immune response that protects the body from further, more virulent **infection**.

IMMUNOLOGY

The study of the immune system of humans and other animals.

IN PARALLEL

Describing part of an electric circuit that splits at one point and rejoins again. Two or more components in parallel receive the same **voltage**. Compare **in series**.

IN SERIES

Describing part of a circuit in which the components are connected one after the other. The electric **current** through each circuit component is the same, but the **voltage** across each component may be different. Compare **in parallel**.

INCISION

A cut made during a surgical operation.

INCUBATION

The process of keeping an unhatched egg warm before it hatches. Birds normally incubate their eggs by sitting on them to insulate them with their feathers.

INDICATOR

A substance, usually based on natural plant material, whose color changes according to the **acidity** or **alkalinity (pH)** of its environment. Indicators such as litmus solution and universal indicator are used in chemical analysis.

INDUCTION

The apparent charging of one object by an **electrically charged** object nearby. The charging is apparent, since it is only a shift of electric charge within the object. Induction is the magnetization of iron objects in the presence of a magnet. The **domains** inside the iron line up with the **magnetic field** of the magnet.

INERT

Relating to an unreactive chemical **compound**.

INERTIA

The resistance of an object to any change in its motion.

INFECTIOUS

The invasion of a host by a disease-causing **parasite** such as a **bacterium**. An infection can also be a name for an affected area.

INFRARED RADIATION

A type of **electromagnetic radiation**, with a **wavelength** that is longer than visible light.

INSULATION

The covering or wrapping up of an object with a material that does not conduct heat well. Some animals are covered with insulating fur.

INTERCOSTAL MUSCLE

Muscle that lies between the ribs.

INTERFERENCE

The combination of two or more **waves**.

INVERTEBRATE

An animal without a backbone.

ION

A **particle** with **electric charge**, formed when an **atom** gains or loses **electrons**. A positive ion is called a **cation**, and a negative ion is an **anion**. Groups of atoms with electric charge (sometimes called radicals) may also be called ions. An example is the carbonate ion, CO_3^{2-} .

IONIC BONDING

A type of bonding in which **cations** and **anions** are held together by forces due to their **electric charges**. The ions form a crystal structure called a **macromolecule**.

ISOTOPE

One of the possible forms of an **element** that differ in their nuclear structure. Although all atoms of a particular element have the same number of **protons** in the nucleus, there may be different numbers of **neutrons**. Different isotopes of an element have the same chemical properties but different **RAMs**.

JOINT

The point of contact between two bones. There are three main types of joints: immovable joints; slightly movable joints; and freely movable joints.

KL

KELVIN SCALE

The absolute scale of **temperature**. The Kelvin scale begins at **absolute zero** and, unlike the Celsius and **Fahrenheit** scales, does not rely on fixed points.

KINETIC ENERGY

The **energy** that a **particle** or an object possesses due to its motion or vibration. The more **mass** an object has and the faster it moves, the more kinetic energy it possesses. Heat energy is the kinetic energy of the random motion of the **atoms**, **ions**, and **molecules** that make up matter.

KREBS CYCLE

A series of **chemical reactions** in plants and animals that respire aerobically. The most important yield of the Krebs cycle is **ATP** (adenosine triphosphate), which is a source of **energy** for the cell's vital functions.

LATENT HEAT

Heat **energy** that melts a solid or vaporizes a liquid. Latent heat does not raise the **temperature** of the substance.

LATITUDE

With **longitude**, one of two coordinates that defines any position on the Earth's surface. Latitude ranges from 90° south (South Pole) through to 0° (**equator**), and up to 90° north (North Pole).

LENS

A curved piece of glass or other transparent material that refracts light and can form **images**.

LIGAMENT

A tough but flexible strand of **tissue** that holds two bones together at a movable joint.

LIGHT YEAR

The distance light travels in one year in free space, measuring approximately 9.465×10^{12} km (5.879×10^{12} miles).

M

LIMITING FRICTION

The force that must be overcome to start an object moving when it is in contact with a surface.

LITHOSPHERE

The Earth's outermost solid layer. Also referred to as the crust, although the liquid mantle and the core are sometimes included in the definition.

LONGITUDE

Along with **latitude**, longitude is one of two coordinates that defines any position on the Earth's surface. Longitude is an angular measure, with 0° passing through Greenwich, London.

LUMINESCENCE

The emission of light due to a decrease in the energy level of an **excited electron** within an **atom** or **molecule**. The two main types are **fluorescence** and **phosphorescence**.

LUMINOSITY

A measure of the total amount of energy radiated by a star. Luminosity is directly related to **absolute magnitude** and less directly related to **apparent magnitude**.

MACROMOLECULE

Any **molecule** with an **RMM** greater than about 10,000. The term is often used to refer to ionic crystals, such as those of sodium chloride.

MAGMA

Molten material found in the Earth's mantle that forms **igneous rocks** when it cools.

MAGNETIC FIELD

A field of **force** around a magnet's poles or around a wire carrying an **electric current**.

MAIN SEQUENCE

The main part of the evolution of a star. The Sun is a main sequence star. The term is related to the Hertzprung-Russell diagram.

MASS

The measure of an object's **inertia**. Mass is also defined in terms of **gravitation**. The gravitational force between two objects depends upon their masses.

MATTER

The matter that inhabits space. Matter has **mass** and therefore **inertia**.

MELTING POINT

The **temperature** at which a solid substance becomes a liquid. It is dependent upon **atmospheric pressure**.

MENISCUS

The curved surface of a liquid where it meets its container. It is caused by a combination of **adhesive** and **cohesive forces**.

MENSTRUAL CYCLE

The repeating period, of about one month, during which eggs (ova) are released from the ovaries of primates, including human females.

MESON

A **hadron** consisting of two **quarks**. An example is the pi meson, which carries the

strong nuclear force between **protons** and **neutrons** within the **nucleus**.

METABOLIC RATE

A measure of how quickly metabolic reactions occur within a human body. People with a high metabolic rate are more likely to be thin.

METAMORPHIC ROCK

Relating to rocks that are formed as **sedimentary** or **igneous rocks** and are subjected to **high pressures** or **temperature** in the Earth's crust. Metamorphic rocks consist of the same **minerals** but have different crystal structures.

METAMORPHOSIS

The transformation of the larval stage of certain **amphibians** and **invertebrates** into the adult stage. Metamorphosis often involves the growth of legs or wings.

MICROMETER

A device used to measure very small **displacements**.

MICROORGANISM

An **organism** that is too small to be seen without the aid of a microscope, such as a **bacterium**. Microorganisms are also known as **microbes**.

MICROWAVE RADIATION

Electromagnetic waves with a **short wavelength**. Microwaves are produced in a similar way to **radio waves**, but they have a **higher frequency**.

MINERAL

Any **element** or **compound**, normally occurring naturally as **crystals**. Rocks consist of two or more minerals.

MITOCHONDRION

A structure found in all plant and animal cells that is associated with the production of available **energy**. The **enzymes** that take place in the **Krebs cycle** are manufactured in the mitochondria.

MIXTURE

Two or more pure substances (**elements** or **compounds**) that are mixed but not chemically combined. The components of a mixture can be separated by methods such as **chromatography** and **filtration**. **Solutions** and **colloids** are two types of mixtures.

MOLE

A unit of the amount of a substance, defined in terms of the number of **particles** that are present. One mole of a substance contains 6.02×10^{23} particles and has a **mass** in grams equal to its **RAM** or **RMM** – so the mass of one mole of copper is 64.4 grams. The quantity $6.02 \times 10^{23} \text{ mol}^{-1}$ is Avogadro's number.

MOLECULAR

Pertaining to **molecules**.

MOLECULAR ORBITAL

A region within a **molecule** in which the **electrons** involved in **covalent bonding** are likely to be found. Molecular orbitals are formed by the overlap of the outer **orbitals** of the atoms that are bound together.

MOLECULE

The smallest unit of many **compounds**. It consists of two or more **atoms** held together by **covalent bonding**.

MOMENT

The turning effect of a **force**.

MONOCOTYLEDON

(**MONOCOT**)
See **cotyledon**.

MOTILE

Describing a **microorganism** that can move, often using a "tail," called a *flagellum* or oscillating "hairs," called *cilia*.

MOLT

The loss of hair, feathers, or fur from birds and mammals, or the integument (outer skin) from arthropods or reptiles.

MUCUS

A fluid mixture that is secreted by **cells** in the respiratory system and alimentary canal.

MULTICELLULAR

An **organism** that consists of more than one **cell**.

MYCORRHIZA

A **symbiotic** relationship between a fungus and the root of a plant.

N**NEBULA**

A hazy object that is observed, most of them only with a telescope, in the night sky. Most nebulae are the birthplaces of stars.

NERVOUS REFLEX

An involuntary muscular action brought about by a particular stimulus.

NERVOUS SYSTEM

The brain, spinal cord (nerve cord in **invertebrates**), and all other **neurons** that carry information between sensory neurons and motor neurons.

NEURON

A long single **cell** within the body of an animal. The brain and spinal cord consist of billions of neurons.

NEUTRON

One of the **particles** in the **nucleus** of an **atom**. It is a **hadron** and has zero **electric charge**.

NEWTON METER

A device used to measure **force**. A pointer moves along a scale as a spring inside the meter extends. The extension of the spring depends upon the force that has been applied.

NIPPLE

The raised center of a mammary gland, present in female mammals, through which lactated milk is made available to newborn young.

NOBLE GAS

Any of the elements of group 18 of the periodic table. These elements are all **gases** at room **temperature** and are very **unreactive** because their outer **electron shells** are filled.

NUCLEAR FISSION

See **fission**.

NUCLEAR REACTION

A change, such as **fission** and **fusion**, that involves the **nuclei** of **atoms**.

NUCLEOTIDE

The monomer from which the **polymers** **DNA** or **RNA** are formed.

NUCLEUS

(Life Sciences and Ecology) The part of a **cell** that holds genetic information as **DNA**. **Bacterial cells** have no nucleus.

NUCLEUS

(Physics) The central, positively charged part of an **atom**, made up of **protons** and **neutrons**. The common **isotope** of hydrogen is the only type of atom that does not have neutrons in its nucleus.

NUTRIENT

A substance that gives sustenance to an **organism**.

NUTRIENT MOLECULE

Any **molecule** of the groups of **compounds** essential to a balanced diet. In humans, these groups are **carbohydrates**, **proteins**, fats and vitamins, and **minerals**.

O**OMNIVOROUS**

Relating to animals that eat both meat and vegetation. Compare **carnivorous** and **herbivorous**.

ORBIT

The path of a planet around the Sun, or the path of a satellite around a planet. The orbit exhibits circular motion (or motion in an **ellipse**), with the **centripetal force** supplied by **gravity**.

ORBITAL

The region of space around an **atom**, an **ion**, or a **molecule** where **electrons** are likely to be found. In an atom, the simpler types of orbitals are called s-, p-, and d-orbitals. Atomic orbitals hold up to two electrons each.

ORE

A **mineral** containing metal **atoms**, normally combined with atoms of oxygen or other **elements**.

ORGAN

Any group of cells that carries out a specific task within the body of a plant or an animal (including humans).

ORGANELLE

A tiny object within a biological **cell** that carries out a specific function.

ORGANIC

Relating to a **compound** based on chains or rings that are formed by carbon atoms. These compounds are the basis of life as we know it. Organic chemistry is the study of such compounds.

ORGANIC MOLECULES

Molecules of **organic compounds**.

ORGANISM

Any living thing.

OSCILLATOR

An electric circuit that produces an alternating **electric current**, which repeatedly changes direction.

PQ

OVARY

The part of a female animal where eggs (ova) are produced. Also, the part of a **carpel** of a flower in which fertilization of the ovules takes place.

OVI PAROUS

An animal that lays eggs outside its body.

OXIDATION

The removal of **electrons** from, or the addition of oxygen to, an **atom**, an **ion**, or a **molecule**. An **element** that is oxidized increases its **oxidation number**.

OXIDATION NUMBER

A positive or negative number that indicates whether an **element** has lost or gained **electrons** during a **chemical reaction**. When copper atoms lose two electrons to form doubly charged copper(II) ions, Cu^{2+} , the oxidation number of copper (initially 0) becomes +2, also given by the Roman numeral II.

OXYGEN

A chemical **element** essential to most living **organisms**. It is produced by plants during **photosynthesis** but is used as a **reactant** during animal and plant **respiration**.

OXYGEN FREE RADICAL

A single, negatively charged oxygen **atom**. As with all free radicals, it is highly reactive.

PARABOLA

An important curve used as the basis of the shape of parabolic dishes. It is one of the conic sections.

PARAMEDIC

A medical professional who specializes in **first aid** and who is also trained to carry out certain other medical procedures.

PARASITE

An **organism** in a **symbiotic** relationship that lives on or in another organism (the **host**). This is a relationship that causes harm to the host.

PARENTAL CARE

The behavior of certain animals that increases the chances of survival of their young.

PARSEC

A standard unit of distance used by astronomers. It is equal to 3.26 **light years**.

PARTICLE

Any tiny, distinct object. The term is specifically applied to **molecules**, **atoms**, and subatomic particles.

PEDIPALP

A sensory appendage in the **anatomy** of spiders and scorpions. In some spiders, the pedipalp is involved in sexual activity, often to carry sperm.

PELVIC REGION

Part of the lower **abdomen** in human **anatomy**. The pelvic girdle is a bony structure, found in all **vertebrates**, to which the posterior (back) legs or dorsal fins are attached.

PELVIS

The lower part of the human **abdomen**, generally defined by the bones of the pelvic girdle.

PENTARADIATE SYMMETRY

Fivefold radial symmetry associated with, for example, starfish.

PERIHELION

The point in an object's **orbit** when it is closest to the body it is orbiting.

PERMANENT MAGNET

Objects with a fixed magnetism. The **domains** in a permanent magnet always align to produce a **magnetic field**. Compare **electromagnet**.

PERMEABILITY

The ability of some rocks (and other substances) to allow water to pass through them.

PH SCALE

A scale that indicates whether a solution is acidic or alkaline. The scale runs from 1 (strong acid), through 7 (neutral), to 14 (strong alkali). The pH value relates directly to the **concentration** of hydrogen ions in the **solution**.

PHARMACOLOGY

The study of the chemical treatment of **disease**.

PHASE

(Astronomy and Astrophysics)
The shape that the illuminated surface of an astronomical object (especially the Moon) appears from Earth. The Moon's phase changes gradually in a repeating monthly cycle.

PHASE

(Electronics)
The stage reached in the cycle of a **wave** or vibration.

PHOSPHORESCENCE

A type of **luminescence** in which a substance glows with visible light some time after being **excited**. A phosphor is any substance exhibiting phosphorescence. Compare **fluorescence**.

PHOTON

A **particle** of **electromagnetic radiation**. The energy of a photon depends only upon the **wavelength** of the radiation. A photon can be thought of as a packet of waves.

PHOTOSYNTHESIS

A **chemical reaction** that occurs in green plants, during which the green pigment chlorophyll uses light energy to make **carbohydrates**.

PHYLUM

A category in the classification of **organisms**, below kingdom. Human beings are in the phylum Chordata (animals with backbones).

PHYSIOLOGICAL

The study of the vital functions of **organisms**, such as nutrition.

PHYTOPLANKTON

Tiny **autotrophic** marine **organisms** that are fundamental in ocean food webs.

PLACENTA

The organ that attaches an **embryo** to the wall of the **uterus**.

PLANE WAVE

A wave motion in which the waves are parallel to one another and perpendicular to the direction of the wave's motion.

POLAR NUCLEUS

The **nucleus** of a **cell** during the metaphase stage of meiosis. The two nuclei for the new cells formed during the process occupy opposite ends of the dividing cell and are connected by a fibrous structure called the spindle.

POLLEN

The grains inside **seed-bearing** plants that contain the male **gametes**. They are produced inside the pollen sacs in the **anther**.

POLLINATION

The process by which **pollen** is transferred from the **anther** (male part) of one flower to the **stigma** (female part) of another flower.

POLYGON

A flat shape with straight sides. Examples of polygons are triangles, squares, and pentagons.

POLYHEDRON

A solid (three-dimensional) shape with a **polygon** as each face. The plural of *polyhedron* is *polyhedra* or *polyhedrons*.

POLYMER

A large molecule that is formed by the joining of smaller molecules – units called monomers – in a reaction called polymerization.

POSITRON

The **antiparticle** of the **electron**. It is identical to the electron in every way, except that it has a positive **electric charge**.

POTENTIAL ENERGY

Energy that is “stored” in some way. For example, an object held in the air has potential energy by virtue of its height and the **gravitational force** pulling it downward.

PRECIPITATE

A solid substance formed by a **chemical reaction** taking place in a **solution**. Precipitates often form during **double decomposition** reactions.

PREDATOR

A **carnivorous organism** that hunts and eats other animals.

PREHENSILE

Part of the anatomy of an animal that is specially adapted for gripping. Some monkeys have prehensile tails that help them to stay balanced on tree branches.

PRESSURE

A measure of the concentration of a **force**. The pressure exerted by a force is equal to the size of the force divided by the area over which it acts. Solids, liquids, and gases exert pressure.

PRIMARY COLOR

Any of a set of three colors, which, when combined in the correct proportion, can produce any other color. The set of primaries for the **additive process** is different from that for the **subtractive process**.

PRINCIPLE OF SUPERPOSITION

The rules governing the **interference** of waves.

PRINCIPLE OF THE CONSERVATION OF ENERGY

Energy can be neither created nor destroyed; it can only change or be transferred from one form to another.

PRODUCT

An **element** or **compound** that is formed in a **chemical reaction**.

PROTEIN

An **organic polymer** that contains carbon, hydrogen, oxygen, and nitrogen. Most proteins also contain sulfur.

PROTEIN SEQUENCE

The sequence of **amino acids** that make up a **protein**. Each protein has a unique sequence that is coded for in the **genes** of an **organism**. See **genetic code**.

PROTEIN STRUCTURE

The structure of a protein depends on the way in which its component polypeptides are arranged. **Proteins** may be described as globular or fibrous.

PROTON

A particle with a positive **electric charge**, which is found in the **nucleus** of every **atom**. The charge on a proton is exactly the opposite of that on an **electron**.

PROTRUSIBLE

A part of an **organism** that can be made to protrude (stick out).

PUPA

The third stage in the life cycle of some insects. It is during this stage that **metamorphosis** takes place, for example when a caterpillar becomes a butterfly.

PYRUVIC ACID

An important **carboxylic acid**, which is essential in **metabolism** as it takes part in the **Krebs cycle**.

QUARK

Particles, such as **protons** and **neutrons**, that combine together to form **hadrons**. No quark has ever been detected in isolation.

QUASAR

Quasars have huge **redshifts** and are the most distant objects known, being up to 10 billion **light years** away.

R**RADAR**

An acronym for *radio detection and ranging*. A technique for determining the distance and direction of an object (typically airplanes) by reflecting pulses of **radio waves** off them. It has been applied to mapping the surfaces of planets and their moons.

RADIAL SYMMETRY

A property of some shapes and some **organisms** whereby rotation through a certain angle results in the same appearance of the shape or organism. Starfish, for example, have radial symmetry.

RADIATION

In its most general sense, any transfer of **energy** that moves outward in all directions. The term is most often applied to **electromagnetic radiation** and can also be applied to the product of **radioactivity**.

RADICAL

An **ion**, normally consisting of two or more nonmetals, that generally remains unchanged during a **chemical reaction**. An example is the carbonate ion, CO_3^{2-} .

RADIOACTIVITY

The breakup (disintegration) of certain atomic nuclei, accompanied by the release of **alpha**, **beta**, or **gamma** radiation.

RADIO WAVES

Electromagnetic radiation, with a frequency of between 3 kHz (kilohertz) and 300 GHz (gigahertz). Radio waves are normally produced by an **antenna**.

RADIUS

Half the diameter of a circle or sphere.

RAINFALL PATTERN

The average or typical rainfall in a particular region or biome over a year. Often shown visually on a **graph**.

RAM

(Chemistry) Abbreviation for *relative atomic mass*. It is the mass of an **atom** of an **element** relative to $1/12$ of the atomic mass of the carbon isotope, carbon-12. RAMs are average values, weighted for the relative natural abundances of different isotopes of an element.

RAM

(Electronics) Abbreviation for *random-access memory*. The RAM is part of the computer's memory whose contents can be changed. It consists of integrated circuits, or microchips, that store the data and programs that are fed into the computer. This data can be retrieved from the RAM in any order and can be altered and added to.

RAREFACTION

The lowering of the **density** and **pressure** of a gas; the opposite of **compression**.

RATE OF REACTION

How quickly a **chemical reaction** proceeds. It depends upon various factors, including **temperature**, and may be increased by using a **catalyst**.

REACTANT

An **element** or **compound** that is the starting material of a **chemical reaction**.

REACTION

A **force** produced by an object that is equal and opposite to a force applied to the object.

REACTIVITY

A measure of the ease with which an **atom**, an **ion**, or a **molecule** reacts. Elements in groups 1 and 17 of the periodic table are generally the most reactive.

RECEPTOR SITE

The location of a nerve ending that is sensitive to a particular type of stimulus. For example, some painkilling drugs act by blocking pain receptors and

preventing the chemicals that stimulate those sites from acting.

REDSHIFT

The apparent shift of a **spectrum** of light, or other **electromagnetic radiation**, to longer **wavelengths**. This is due to the extreme **speed** at which the source of the light is receding from Earth. Galaxies in every direction have redshift, indicating that they are all receding, and suggesting that the universe is expanding.

REDOX REACTION

Any **chemical reaction** that involves the transfer of **electrons** (**reduction** and **oxidation**). Nearly all reactions can be seen as redox reactions.

REDUCTION

The addition of **electrons** to, or the removal of oxygen from, an **atom**, an **ion**, or a **molecule**. The **oxidation number** of an **element** that is reduced decreases.

REFRACTION

The bending of light, or other **electromagnetic radiation**, as it passes from one material to another.

RESISTANCE

A measure of the opposition to the flow of **electric current**. It is the ratio of **voltage** to current.

RESISTANT

A **parasitic**, **disease-causing organism** that has evolved a resilience to the drugs and other treatments that would otherwise destroy it.

RESISTOR

An electronic component that has a **resistance** that is determined precisely at the factory. Variable resistors have controllable resistance and may, for example, be used as volume controls in amplifier circuits.

RESPIRATION

The process in plants and animals in which nutrients are broken down, releasing **energy** and waste products. See **aerobic**, **anaerobic**, **Krebs cycle**.

RESULTANT

The combined effect of two or more **forces**.

RETROVIRUS

A **virus** whose RNA produces DNA inside the **host cell**. The viral DNA then becomes incorporated into the host's DNA. This is the mechanism for many **viral** diseases.

REVERSIBLE REACTION

A **chemical reaction** in which the **products** react to form the **reactants** once again.

RIBOSOME

A small body within a cell that is involved in the transcription (copying) of DNA. A ribosome consists of RNA and a **protein**.

RILL

A stream or brook.

RMM

Abbreviation for relative molecular mass. RMM is the sum of the RAMs of the **elements** that make up a **compound**. For example, the RMM of water, H₂O, is 18, this is because the RAM of hydrogen is 1 and the RAM of oxygen is 16.

RNA

Abbreviation for ribonucleic acid. RNA is a complex **chemical compound** that is found in all **viruses** and cells during transcription (copying) of DNA, when **proteins** are synthesized (made).

ROM

Abbreviation for read-only memory. The ROM is part of a computer's memory whose contents cannot be changed. Once data has been recorded into the ROM chip, it cannot be removed or altered; it can only be read.

S**SALIVA**

An alkaline fluid found in the mouth of humans and certain other animals.

SALT

An ionic **compound** that is formed whenever an **acid** and a **base** react together.

SANKEY DIAGRAM

An illustration of the **energy** changes in a process. The diagram consists of a large arrow that represents the input of energy to the process and that splits according to the **energy** changes that occur.

SCALES

The small horny plates that cover the bodies of reptiles. Scales are also the bony plates that cover the bodies of fish.

SCARP

A steep slope in a folded, or belted, landscape that is created by the fold and its subsequent erosion. Scarps are also known as escarpments.

SECONDARY SEXUAL CHARACTERISTIC

External features of animals that are found only in one sex. They affect reproductive behavior but are not directly involved in copulation, for example antlers on male deer.

SEDIMENTARY ROCKS

Rocks that have formed from the **compression** of sediment, such as soil, sand, and salt, over millions of years. Sandstone and limestone are examples of sedimentary rocks. See **igneous** and **metamorphic rocks**.

SEED

A structure found in certain classes of plants that contains the **embryo** and the nutritional substances required for germination. The seed develops from the ovule after **fertilization**.

SEISMIC

Concerning earthquakes. Seismology is the study of earthquakes.

SEMICONDUCTOR

A material in which the **electrons** are held only loosely to their **atoms**. Only a small input of energy is needed to free the electrons and therefore make the material **conductive**.

SEMIMETAL

An **element** that shows characteristics between those of metals and nonmetals. Semimetals are fairly good **conductors** of heat and electricity. They are also known as metalloids.

SENSE ORGAN

A part of the body of an animal that consists of a concentration of **receptor cells**. See **sensory receptor**.

SENSORY RECEPTOR

A **cell**, or group of cells, that produce nerve impulses under certain conditions. **Cone cells** are receptors that produce impulses when light of a particular range of colors falls on them.

SESSILE

Being attached to a surface. Limpets are sessile for much of their time, as they are connected to rocks.

SEX CELLS

See **gamete**.

SHELL

(Chemistry and Physics)
An energy level that is occupied by **electrons** within an **atom**. It is generally accepted that the lower the energy of electrons in the shell, the closer the shell is to the **nucleus**.

SI UNITS (SYSTEME INTERNATIONAL D'UNITES):

A system of units that is accepted by the worldwide scientific community as the standard system. Its seven base units include the kilogram and the second.

SINGULARITY

The central point of a black hole. Einstein's general relativity predicts that a singularity has infinite **density**.

SOLENOID

A long coil of wire that produces a **magnetic field** similar to that of a bar magnet. When an iron bar is inside the coil, a solenoid becomes an **electromagnet**.

SOLUBLE

A **compound** that will dissolve in another compound. Salt, for example, is soluble in water. See **solution**.

SOLUTE

The substance that dissolves in a **solvent** to form a **solution**.

SOLUTION

An even **mixture** of two or more substances in which the particles involved are **atoms**, **ions**, or **molecules**. The **solvent**, a solid, liquid, or gas, dissolves one or more other substances (the **solutes**) to form a solution.

SOLVENT

The substance that a **solute** dissolves into to form a **solution**.

SPACE-TIME

A concept that arose as a result of Einstein's special relativity theory, in which the three dimensions of space are combined with the one dimension of time.

SPECIES

The lowest level in the classification of living **organisms**. Humans are of the species *Homo sapiens*.

SPECTROGRAPH

A **spectrometer** that has a photographic plate or some other way of recording the observed **spectra**.

SPECTRAL TYPE

A classification system for stars, which is based on the **spectra** of the stars observed through a

spectrometer. Spectral type is also known as spectral class.

SPECTROMETER

Every **element** or **compound** produces a unique **spectrum**, which corresponds to **energy** levels in its **atoms**, **ions**, or **molecules**. A spectrometer is an instrument that is used to analyze a spectrum during chemical analysis. Spectroscopes are spectrometers that use light. Astronomers use spectroscopes to determine the compositions and spectral types of stars. See **spectrograph**.

SPECTRUM

A distribution of some property according to a continually changing quantity. The term usually refers to the white light spectrum, in which the colors that make up white light are arranged in order of their **wavelengths**.

SPEED

The rate at which an object moves, equal to the distance moved divided by the time taken.

SPINAL NERVES

Pairs of nerves that stem from the spinal cord. Each spinal nerve consists of a sensory and a motor **neuron**.

SPIRACLES

Small openings on either side of the head of a **cartilaginous** fish.

SPORE

A cell that is involved in **asexual** reproduction and which can develop into an individual without **fertilization**. Compare **gamete**.

STAMEN

One of the male parts of a flower. The fertile part – the **anther** – is held up by a stalk called a filament.

STATE

The form of a substance, which can be solid, liquid, or gas.

STIGMA

The sticky part of the **carpel** of a flower that receives **pollen**.

STP

Abbreviation for standard **temperature** and **pressure**. STP equals 0° C (32° F) and **atmospheric pressure** (101,325 Nm⁻²).

STRATUM

A distinct layer of **sedimentary** rock. Older strata are below younger ones because they were laid down first.

STREAMLINED

A shape that will pass through a **fluid** with little resistance. A car, for example, is designed with a shape that will reduce **air resistance**.

STRESS

Force per unit area on an object that is being **compressed** or stretched. Stress causes a deformation of the object, which is called strain.

STRONG NUCLEAR FORCE

The force between **hadrons**, which is carried by **gluons** or by combinations of **quarks** (see **gauge boson**). The strong nuclear force is responsible for holding the **nucleus** together.

STYLE

The stalk of a **carpel** that, in the female part of a flower, holds up the **stigma**.

SUBDUCTION ZONE

A region of the Earth's crust in which one **tectonic plate** is forced under another.

SUBLIMATION

The direct change from a solid to a gas.

SUBTRACTIVE PROCESS

The process by which pigments absorb parts of the visible **spectrum** of light but reflect others, making objects appear to have color.

T

SUPERCOOLED LIQUID

See **amorphous solid**.

SUPERFICIAL MUSCLE

A muscle found just under the skin. Compare **deep muscle**.

SUPERNOVA

The brightening of a star, which happens as **fusion** at the star's core. When activity in the core stops, the star collapses, and this leads to a massive explosion that throws the star's outer layer off into space.

SURFACE TENSION

The resultant **force** at the surface of a liquid that is due to the **cohesive forces** between the **particles** of the liquid.

SUSPENSION

A type of **mixture** in which **particles**, larger than those in a **colloid**, are unevenly distributed in a liquid or a **gas**. Suspensions can be separated by **filtration**. Muddy water, for example, contains soil particles in suspension.

SYMBIOSIS

A relationship between two **species**. Symbiotic relationships may have several different effects on the species involved: it may harm one of the species to the benefit of the other (parasitism); it may benefit both species (mutualism); it may not benefit either (commensalism).

SYMPTOM

Any number of physical signs that are used in the **diagnosis** of a **disease**. For example, increased body **temperature** is a symptom that is common to many diseases.

SYSTEM

A physical arrangement, used in formulating physical theories. A system is open if **energy** can enter or leave it but closed if it cannot.

TECTONIC PLATE

The large pieces of which the Earth's crust is made. Tectonic plates are constantly moving; where they meet, earthquakes and volcanoes are common. See **subduction zone**.

TEMPERATE

Describing a climate of the middle **latitudes** (30° to 40° north or south).

TEMPERATURE

A measure of how hot or cold a substance is. The temperature of a substance is directly related to the average **kinetic energy** of its **atoms**, **ions**, or **molecules**.

TENDON

A strand or sheet of **tissue** that connects muscles to bones.

TENSION

A reaction **force** in a solid that is stretched, which pulls the **atoms** of the solid together. It is the opposite of **compression**.

TERMINAL VELOCITY

The maximum **speed** attained by an object falling through a liquid or **gas**. A parachute falling through air has a relatively low terminal velocity, while that of a ball bearing will be much greater.

TERRESTRIAL

Anything that relates to the Earth.

TERRESTRIAL PLANET

Any of the rocky planets of the inner part of the solar system: Mercury, Venus, Earth, and Mars.

TESTA

The tough or fibrous outer covering around a seed.

THERMAL EXPANSION

The expansion of a solid as its **temperature** increases. It is due to the increased vibration of the atoms and molecules of the solid. This increased vibration occurs at higher temperatures,

due to the increased **kinetic energy** of the atoms and molecules.

THERMOCOUPLE

A pair of connected wires of different metals that produces a small **voltage**. The magnitude of the voltage depends upon **temperature**. Thermocouples are, therefore, used in thermometers, particularly at high temperatures.

THORAX

The front of the **trunk** of an animal. In **vertebrates** it contains the heart and lungs, in insects it is divided into a front prothorax, a middle mesothorax, and an anterior metathorax.

TISSUE

Any collection of **cells** of a particular type that forms a distinct part of a plant or animal. A lung, for example, is made up of different tissues from those of the heart.

TITRATION

A procedure in which a measured amount of one **solution** of known **concentration** is added to another solution, usually in order to determine the latter's concentration.

TOPOLOGICAL

Concerning topology, which is the study of the abstract properties of shape.

TOTAL INTERNAL REFLECTION

Light rays that pass through a dense substance (such as a glass block) and are reflected from its inner surface back into the substance.

TRANSDUCER

Any device that changes one form of **energy** into another. A microphone, for example, changes sound into electrical energy.

TRANSITION METAL

The elements that are found in the d- and f-blocks of the

periodic table. Most metals, including iron and copper, are transition metals.

TRANSPLANT SURGERY

Surgery in which **organs** or **tissues** are transferred from one person to another, or from one part of an individual to another part of the same individual.

TROPICAL

Describing a climate typical of the tropics, the regions 23½° north and south of the equator.

TRUNK

The central part of the body that contains the heart, lungs, and other vital **organs**.

TURBINE

A machine in which a liquid or a **gas** causes rotation. When attached to a **generator**, the turning of the turbine helps to generate electricity.

U

ULTRASOUND

A sound of frequency that is too high for the human ear to perceive. It is usually taken as above 20,000 Hz.

ULTRAVIOLET (UV)

Electromagnetic radiation of wavelength that is shorter than visible light, in the range 400 - 200 nm.

UNICELLULAR

An organism that consists of just one cell. Bacteria, for example, are unicellular.

UNIT CELL

The group of atoms or molecules in a crystal; when repeated, it forms the crystal lattice. There are seven naturally occurring unit-cell types.

UPTHRUST

An upward force on an object immersed in a liquid or a gas. Upthrust is the resultant of the liquid or gas pressure acting on the object. Upthrust supports ships in the ocean and hot-air balloons in the air.

URINE

A water-based fluid that is excreted by animals. In most reptiles and mammals urine is excreted from an organ called the bladder.

UTERUS

The organ in a female mammal in which the embryo develops. The uterus is also known as the womb.

V

VACCINE

A liquid that contains disease-producing microorganisms, which, when introduced to the body, trigger the production of antibodies. These antibodies protect the body against the full onset of the disease.

VACUUM EXTRACTION

A method of assisted childbirth in which a suction cap is fitted onto the baby's head to enable the midwife or doctor to pull the baby through the birth canal.

VARIABLE

A term in an algebraic equation that can take a number of different values. Compare constant.

VASCULAR SYSTEM

The part of the circulatory system in animals that is involved with blood circulation in animals. It is also a system that enables the circulation of fluids around plants.

VECTOR

A quantity, often represented visually as an arrow, that has both magnitude and direction. Displacement and velocity are vectors.

VELOCITY

The speed and direction of an object's motion.

VERNIER SCALE

A scale, which is attached to an instrument such as callipers, to allow very accurate measurements to be taken.

VERTEBRATE

An animal with a backbone.

VIRUS

A tiny object that is composed of RNA or DNA and is surrounded by a protein coat or capsid. A virus is not capable of independent reproduction and relies on a host cell from a living organism to enable it to reproduce.

VISCERAL

Relating to the viscera, or internal organs that are present in the thorax and abdomen of mammals.

VOLTAGE

A measure of the electromotive force on particles with electric charge. The voltage in an electric circuit pushes electrons around the circuit.

VOLUME

The amount of space an object takes up. This is measured in cubic meters (m³).

WXZ

WATER OF CRYSTALLIZATION

Water that is held in crystals of a compound.

WAVE

A transfer of energy that is caused by a vibration. For example, the vibrations that cause sound travel as waves.

WAVELENGTH

The distance from one wave peak to another. The wavelength of electromagnetic radiation determines the type of radiation. For example, X rays have a shorter wavelength than light. Light of different wavelengths causes the sensation of color.

WEAK INTERACTION

A force between some types of particle, including electrons. Weak interaction is also involved in the decay of hadrons, such as the beta decay of neutrons in the nucleus. The force is carried by *W* and *Z* particles. See gauge boson.

WEIGHT

The force of gravity on an object. It is dependent on the mass of the object. Weight is therefore variable under different gravitational conditions, such as on other planets.

WHOLE NUMBER

Any of the numbers ...-3, -2, -1, 0, 1, 2, 3...

WORK

The amount of energy involved in a particular task. For example, work is said to be done when a pulley lifts a load. The amount of work done is equal to the force acting multiplied by the distance moved.

X RAYS

Electromagnetic radiation of wavelength between 10⁻¹¹ to 10⁻¹⁰ m.

ZYGOTE

A fertilized female gamete.

Index

- A**
- Abacuses 560
- Abbreviations
electronics and computers 391
- "ABC," emergency care 244
- Abdomen 398
crustaceans 154
human anatomy 180, 208, 212, 216-21
mammals 166
- Absolute magnitude, stars 501, 524, 525, 598
- Absolute zero 52, 398
- Absorption
color 50
light 52
- AC see Alternating current
- Acamar 587
- Acanthocephala 135
- Acceleration 398
formula 578
measurement 22, 25
Newton's Laws 22, 25
terminal velocity 24
theory of relativity 62, 65
- Accessory organs,
digestive system 196
- Accessory pancreatic duct 197
- Accretion disks, black holes 550, 551, 598
- Acetabulum 183
- Acetylsalicylic acid 579
- Achernar 588
- Achromatic doublets 398
- Acid-base reactions 67
- Acid rain 174
- Acid salts 86, 87
- Acidic lava 275
- Acids 84-5, 398
and alkali metals 98
ammonia fountain 95
fatty acids 99
neutralization 85
pH scale 84
reaction rates 80, 81
reactive metals 94, 95
salts 86
voltaic cells 97
- Aconagua 582
- Acorn worms 135
- Acquired Immune Deficiency Syndrome (AIDS) 258
- Acrasiomycota 131
- Acres 376, 377
- Acromion 227
- Acrux 389
- Acrylic, structure 379
- Actinia equina 150
- Actinides 102
periodic table 74-
Actinium 74
- Actinotroch
sphyrodeta 150
- Activation energy 90, 398
- Activity series 94-5
- Acupuncture 256
- Acute angles 366
- Adam's apple 194, 205
- Adaptive radiation,
evolution 128
- Adders, logic gates 370
- Addition, computers 370
- Additive process, color 50, 51, 398
- Address lines,
computers 552
- Aden, Gulf of 275
- Adenine 115
- Adenohypophysis 188
- Adenosine triphosphate (ATP) 598
photosynthesis 148
respiration 124
- Adhara 586, 589
- Adhesive forces 598
capillary action 56
liquids 56
- Adipose tissue 181
- Adrenal glands 188, 189, 220
- Adrenaline 188, 189
discovery of 179
- Advanced life support 398
- Adventitious buds 126
- Adventitious roots
ferns 159
flowering plants 145
- Aeration zone, rocks 284
- Aerial roots 145
- Aerobic respiration
energy yield 124, 195
mitochondria 122, 125
oxygen cycle 175
- Aerosols, CFCs 111
- Afferent lymphatic vessels 195
- Africa
data 382
formation of 275
Great Rift Valley 275, 276
- African plate 272
- Agar 398
culture plates 258
- Agassiz, Jean Louis 267, 394
- Agnatha 135
- Agricola, Georgius 66, 266, 394
- Agriculture 120
human impact on environment 174
- AIDS see Acquired Immune Deficiency Syndrome
- Air
diatomic molecules 77
diffusion 58
four-elements theory 66
gases 106
liquefaction 32
mixture 70
nitrogen 106
noble gases 106
oxygen 108
respiratory system 194, 195
soap bubbles 56
sound waves 50, 51
total internal reflection 52
upthrust 37
see also Atmosphere
- Airfoils, birds' wings 165
- Air masks 244
- Air masses, fronts 295
- Air molecules
Brownian motion 16
evaporation 16
sound waves 50, 51
- Air pressure
discovery of 15
increasing pressure with depth 37
isobars 295
sound waves 51
- Air pumps 66
- Air resistance 24, 398
- Air sacs, birds' eggs 164
- Airway, emergency care 244
- Al' Aziziyah 382
- Al Nair 587, 588
- Ala 211
- Alarm clocks, LEDs 347
- Alba Patera, Mars 315
- Albireo 588
- Alchemy 66
- Alcmaeon of Croton 179, 394
- Alcohol
cloud chambers 58
fermentation 88, 89, 156
formula 379
paper chromatography 70
- Alcor 387
- Alcyone 388
- Aldebaran 586, 589
- Alderamin 587
- Algae 134, 398
blue-green 154
classification 150, 151
diatoms 155
evolution 268
green 155
lichens 157
pollution 174
- Algebra 362-5
Boolean 557, 559, 371
calculus 359
history 358
probability and statistics 568
rules of 593
- Algedi 588
- Algenib 387, 588
- Algieba 586
- Algol 587, 388
- Alhena 586
- Aliens, space probes 502
- Alimentary canal 196, 197
- Alioth 386, 587
- Alkaid 586, 587
- Alkali metals 98-9
periodic table 74-5
- Alkaline dry cells 96
- Alkaline earth metals 100-1
periodic table 74-5
- Alkalis 84, 598
ammonia fountain 95
ammonia production 106
neutralization of acids 85
pH scale 84
preparation of acid salts 87
solutions 98
- Alkanes 598
combustion 85
fractional distillation 115
hydrocarbons 112
- Alkenes 598
- Alkynes 398
- Allantois, birds' eggs 164
- Alleles 126, 127
- Allergic rhinitis 581
- Allergies 260
mast cells 261
- Alligators 162
- Allotropes 398
carbon 104
phosphorus 106
sulfur 108, 109
- Alloys 598
artificial body parts 252, 255
iron 102
tin 104, 105
- Alluvial deposits 285
- Almach 587, 588
- Alnilam 524, 586
- Alnitak 524, 526, 586
- Alpha Centauri 389
- Alpha decay 58, 598
- Alpha (α) sulfur 109
- Alphard 586, 589
- Alphecca 586, 589
- Alpheratz 587, 588
- Alps 276
- Alrami 589
- Altair 387, 588
- Alternating current (AC) 358, 598
capacitors 542
diodes 546, 547
inductors 544
multimeters 359
- Altitude 598
- Alto clouds 292
- Altostratus clouds 292
- Aludra 589
- Aluminum
in Earth's crust 579
element 68
formula 379
integrated circuit manufacture 351
periodic table 75
powder 76
reactivity 94
thermite reaction 90, 91
- Aluminum oxide 68, 76
- Electrolytic capacitors 543
reactivity 94
thermite reaction 91
- Alveoli 194, 195
- Alzheimer's disease 381
- Amanita 157
- Amateur scientists 10
- Amazon River 585
- Ambulances 244
- Ambystoma
mexicanum 161
- American National Science Foundation 357
- Americium 75
- Amino acids 217, 398
enzymes 124
prion proteins 259
protein synthesis 124-5
- Ammeters
electric circuits 45
measuring electric current 44
measuring resistance 42
- Ammonia
in comets 322
dissolution in water 92
fountain experiment 95
Haber process 106, 107
ions 106
on Jupiter 517
laboratory production 106, 107
molecules 68
on Neptune 520
nitrogen compound 106
pH scale 84
on Saturn 518
on Uranus 519
- Ammonites 269
- Ammonium, formula 579
- Ammonium chloride 96, 107
- Ammonium
hydrosulfide, on Jupiter 517
- Ammonium hydroxide 116, 117
- Ammonium ion 106
- Ammonium nitrate 90
- Anniocentesis 256 398
- Amnion
birds' eggs 164
reptiles' eggs 162
- Amniotic fluid
birds' eggs 164
human pregnancy 199
- Amoebas 134
structure 155
- Amoebic dysentery 259
- Amoeboids,
classification 151
- Amorphous solids 54
- Amount of substance, SI units 577
- Amperes, SI units 377
- Amphibia 135
- Amphibians 160-1
classification 155
endangered species 175
evolution 269
- Amplifiers
capacitors 542
integrated circuits 350
invention of 536
mixing desks 341
transistors 549
- Amplitude 50, 398
- Amps 42
- Ampula, echinoderms 151
- Amur, River 585
- Amylases 89
- Anabolic reactions (anabolism) 398
metabolism 124
- Anaerobic respiration,
yeasts 156
- Anaerobically 398
- Anal canal 225, 224
- Anal fins, fish 158, 159
- Anal sphincter
female pelvic region 224, 225
male pelvic region 222, 225
- Analgesics 581
- Analog integrated circuits 350
- Analog multimeters 559
- Analog signals,
computer networks 554, 555
- Analog-to-digital converters 554
- Analysis 70, 116-17
- Analytical geometry 359
- Anaphase, mitosis 126
- Anatomical 398
- Anatomy, human 176-235
history 120, 178-9
- Anaximander of Miletus 120, 121, 267, 394
- Anconeus 229
- AND gates 370
- Andes 276, 277
- Androecium, flowers 145
- Andromeda constellation 586, 587, 588
- Andromeda galaxy 528, 587
- Andromeda Nebula 297
- Anemia 260, 381
- Anemones (cnidarians) 150
- Anemonia viridis 150
- Anesthetics 247
discovery of 257

- Anesthetists 246, 247
 Aneurysm 581
 Angel Falls 585
 Angina 381
 Angiography 241
 Angles
 circumference 267
 cones 365
 crystal systems 54-5
 elliptic geometry 565
 geometry 564
 hyperbolic geometry 365
 light reflection 52
 light refraction 52
 molecular models 68
 SI units 377
 sp³ orbital 105
 total internal reflection 52
 trigonometry 366-7, 595
 Anguis fragilis 163
 Angular momentum
 29, 398
 Anhydrous compounds
 92, 399
 Anhydrous copper
 sulfate 85, 92
 Animalia 150
 Animals
 carbon cycle 175
 cells 122
 classification 120, 121,
 150, 152-5
 ecology 121
 endangered species 175
 energy requirements 580
 evolution 128-9
 extinction 175
 food chains 170
 gestation periods 580
 homes 580
 lifespan 580
 natural cycles 172-5
 nitrogen cycle 172
 oxygen cycle 173
 pollination 142, 144
 seed dispersal 147
 speed 580
 transplants 250
 vivisection 178
 Anions 399
 chemical reactions 80
 halogens 110
 nonmetals 76
 salts 86
 testing for 117
 Ankle 180, 255
 Annapurna 585
 Annelid worms 152
 Annelida 152, 152
 Anne's spot, Saturn 318
 Annual flowering
 plants 142
 Annulus, gilled
 mushrooms 137
 Anococcygeal ligament
 222, 225
 Anodes 547, 599
 cathode-ray tubes 57, 336
 Downs Process 77
 electrodes 97
 electrolytic cells 96
 electroplating 97
 Antacids 581
 Antarctic plate 272
 Antarctica
 data 382
 ice sheet 282, 285
 ozone layer 174, 374-5
 Antares 586, 589
 Anteaters, energy
 requirements 580
 Antennae 399
 butterflies and moths 157
 centipedes and
 millipedes 157
 crustaceans 154
 water fleas 154
 Antennae, radio waves
 48, 599
 Anterior 599
 Anterior lobe, pituitary
 gland 188
 Anterior median fissure,
 spinal cord 186
 Anterior sacral
 foramen 211
 Anterior superior iliac
 spine 217
 Anterior tubercle 211
 Anters 145, 144, 399
 insect-pollinated
 plants 146
 pollination 146
 succulent fruit 147
 wind-pollinated
 plants 146
 Anthocerophyta 151
 Anthophyta 151, 142
 Anthozoa 152
 Anti-suck-back device
 85, 110
 Antibiotics 258, 259,
 581, 599
 discovery of 237
 topical drugs 255
 Antibodies 193, 260, 599
 B cells 250, 260
 in blood 191
 immunization 261
 lymphatic system 192
 transplant and graft
 rejection 250
 Anticline, folds 277
 Anticlockwise moment 21
 Anticyclones 291
 Antidiuretic hormone 188
 Antifungals, topical
 drugs 255
 Antigens 195, 260, 599
 immunization 261
 transplant and graft
 rejection 250
 Antihistamine 581
 Antimony 75
 Antiparticles 599
 particle accelerators 60
 Antipyretics 581
 Antiseptics, discovery
 of 237
 Antlia constellation 386
 Anus
 annelid worms 152
 crustaceans 154
 echinoderms 151
 female pelvic region 225
 fish 158
 gastropods 155
 human anatomy 196,
 197, 218
 male pelvic region 222
 mammals 166
 Aorta
 human anatomy 190, 191
 insects 156
 vascular grafts 252
 Aortic hiatus 221
 Aortic lymph nodes 192
 Aortic semilunar valve 191
 Apatite 279
 Apes 166, 167
 Aphelion 505, 508, 599
 Apical buds
 conifers 141
 flowering plants 142
 Apollo crater 311
 Apollonius of Perga
 359, 394
 Aponeuroses 184
 abdominal muscles 209
 external oblique
 muscle 185, 208, 209
 Apparent magnitude,
 stars 501, 524, 525, 599
 Appendicular skeleton 182
 Appendix 197, 216, 218, 219
 Appendix epiploica 217,
 218, 219
 Apple Macintosh
 computers 337
 Applied mathematics 558
 Apus constellation 588
 Aquarius constellation
 387, 388
 Aqueous solutions 599
 acids and bases 84
 chemical analysis 116
 nickel nitrate 70
 sucrose 114
 Aquila constellation
 386, 388
 Arabian Desert 585
 Arabian plate 272
 Arabic numbers 560, 576
 Arabs 8
 life sciences 120
 mathematics 558, 559
 physics 14
 Arachnida 155
 Arachnids 154, 155
 Arachnoid 186
 Aral Sea 585
 Archaeobacteria 151
 Archaeopteryx 128, 269
 Archegoniophores,
 liverworts 158
 Archer constellation
 588, 589
 Arches
 coastlines 286, 287
 erosion 280
 Archimedes 15, 394
 Arctic Institute Ice
 Passage 585
 Arctic jet stream 291
 Arctic Ocean
 size 582
 Arcturus 586, 589
 Arcuate deltas 285
 Arcuate ligament 221
 Area 593
 circles 562
 conversion tables 377
 measurements 576
 Areola 208
 Arâtes 285
 Argon
 in air 70, 106
 periodic table 75
 Arguments, logical 370, 371
 Aries constellation 586, 588
 Aril, yew 140
 Aristotle 594
 animal classification
 120, 121
 astronomy 9, 296, 297
 deduction 8
 physics 8, 14
 water cycle 267
 Arithmetic 558
 Arkab Prior 589
 Armpit 181
 Arms
 bones 182
 forearm 180
 joints 185
 mammals 166
 muscles 185, 226-7
 posterior back
 muscles 210
 prostheses 255
 upper arm 180, 226-7
 ARPANET (Advanced
 Research Projects
 Agency Network) 337
 Arrest, Heinrich Louis d'
 297, 394
 Arrhenius, Svante 67, 594
 Arrow worms,
 classification 135
 Arsenic 75
 Arteries 190, 193
 angular 202
 aorta 190, 191
 in abdomen 218,
 220, 221
 ascending aorta
 212, 214
 descending aorta
 215, 215
 dorsal aorta 216
 aortic arch 214
 arcuate 198
 axillary 190, 205, 226
 brachial 190, 226,
 227, 228
 brachiocephalic 191,
 202, 205, 215
 brain 241
 carotid 200
 common carotid 190,
 191, 202, 205, 212, 215,
 214, 215
 external carotid 202
 cerebral 207
 cervical 202
 circumflex 215
 coronary 213, 214
 crustaceans 154
 digital 190
 dorsal metatarsal 190
 dorsalis pedis 255
 facial 202, 205
 femoral 190, 250
 gastric 190, 218
 gastroduodenal 219
 genicular arterial
 network 252
 gluteal 251
 gonadal 220
 grafts 252, 255
 hepatic 217, 218
 humeral circumflex 227
 iliac
 common iliac 190,
 216, 220, 250
 external iliac 220, 221,
 224, 250
 internal iliac 225, 224
 intercostal 215, 215
 lateral malleolar 235
 lingual 202
 measuring blood
 pressure 259
 mesenteric 218
 inferior mesenteric 220
 superior mesenteric
 190, 219, 220, 221
 occipital 202
 ovarian 224
 palmar digital 228
 perforating 251
 peroneal 190, 235
 phrenic 213, 218, 220
 popliteal 190, 251, 235
 profunda brachii 227
 proper hepatic 218
 pulmonary 190, 191,
 213, 214
 pulmonary trunk 212,
 213, 214
 radial 228, 229
 renal 190, 198, 220
 splenic 193, 218, 219
 subclavian 190, 191,
 202, 205, 213, 214, 215
 superficial temporal 202
 superior temporal 202
 temporal 202
 thyroid 202
 tibial 190, 235
 tibial recurrent 232
 transverse cervical 202
 ulnar 190, 228
 Arterioles 188
 Artery forceps 246
 Arthropoda 152, 153, 154
 Arthropods 154-7, 599
 classification 152
 evolution 269
 Articular membrane,
 arthropods 154
 Articulated 599
 Artificial body parts 252-5
 Artificial elements,
 periodic table 75
 Arytenoid cartilage 194
 Ascending colon 196,
 197, 216, 217, 218, 219
 Ascomycota 151
 Ascorbic acid 379
 Asexual reproduction
 126, 399
 liverworts 158
 yeasts 156
 Ash, magnesium oxide 77
 Ash-cinder volcanoes 275
 Asia
 data 582
 formation of 275
 mountain building 277
 Aspergillus,
 classification 151
 Aspirators 244
 Aspirin, formula 379
 Assal, Lac 582
 Association neurons
 186, 187
 Astatine 75, 110
 Asteroid belt 304, 314,
 322, 325
 Asteroidea 155
 Asteroids 322-5
 observational
 techniques 500, 501
 solar system 504
 space probes 502
 Asthenosphere 275
 Asthma 255, 261, 581
 Astronomical units 599
 Astronomy 7, 294-535
 amateur scientists 10
 comets, asteroids and
 meteoroids 322-5
 cosmology 352-5
 data 584-5
 galaxies 528-9
 history 296-7
 Moon 310-11
 neutron stars and black
 holes 350-1
 observational
 techniques 500-1
 planets 508-9, 512-21
 solar system 504-5
 space probes 502-5
 stars 324-7
 Sun 306-7
 telescopes 298-9

- Astrophysics 7, 296
 Asymmetrical folds 277
 Atanasoff, John Vincent 357, 394
 Atlantic Ocean
 formation 269, 275
 Mid-Atlantic Ridge 275
 plate tectonics 272
 size 582
 Atlas vertebra 183, 211
 Atmosphere 290-1, 399
 acid rain 174
 carbon cycle 173
 formation of 268
 global warming 174
 historical theories 266
 ionosphere 267
 Jupiter 316, 317
 Mars 314, 315
 meteoroids 322
 Neptune 320
 nitrogen cycle 172
 ozone layer 110, 111, 174, 267
 Pluto 321
 Saturn 318
 sunlight 306
 Uranus 318, 319
 Venus 312, 315
 water cycle 172
 weather 292
 see also Air
 Atmospheric pressure 37, 399
 sound waves 31
 Atolls 289
 Atomic force
 microscopes 78, 399
 Atomic mass 399
 Atomic number 72, 399
 nuclear physics 58
 periodic table 74
 Atomic orbitals 368
 Atomic weight, periodic table 67
 Atoms 72-3, 399
 absolute zero 32
 activity series 94-5
 alkali metals 98
 alkaline earth metals 100
 atomic diameter 98
 Avogadro's constant 73
 bonds 67, 78-9
 boron 72
 Brownian motion 16
 buckminsterfullerene 104
 carbon 104, 114
 chemical reactions 80
 compounds 68
 crystal systems 34
 discovery of 67
 displacement reactions 94-5
 doping a semiconductor 346
 electric charges 40
 electric circuits 42
 electric current 42
 electrochemistry 96
 electromagnetic radiation 49
 electron shells 72
 electrons 56-7, 72
 elements 58, 68
 energy levels 56
 equalization of temperature 55
 evaporation 16
 friction 24
 gas molar volume 73
 gases 58
 graphite 104
 halogens 110
 heat 90
 heat energy 52
 historical theories 66
 ions 40, 67
 matter 16
 metals 76
 modern chemistry 67
 mole 72
 molecular orbitals 78, 79
 neutrons 72
 nonmetals 76
 nuclear physics 58-9
 nucleus 72
 orbitals 72
 organic chemistry 112, 114
 oxidation 82, 83
 oxidation number 82
 particle physics 60
 precipitation reaction 8
 probability theory 368
 protons 72
 quantum theory 15, 62
 reduction 82
 relative atomic mass (RAM) 72
 relative molecular mass (RMM) 72
 solar cells 47
 solids 34
 solids under tension 35
 solutions 16
 spectral absorption lines 501
 thermal expansion 34
 water 92
 ATP see Adenosine triphosphate
 Atrial systole 191
 Atrium, heart 190, 191, 212, 213, 214
 echocardiography 240
 Atrium, sponges 150
 Attractors, chaos theory 372
 Audio transformers 345
 Auditory meatus (canal) 203, 204, 206
 Auricle, atrium of heart 213, 214
 Auricle, ear 203
 Auriculotemporal nerve 202
 Auriga constellation 586, 589
 Aurora 290
 Auscultation 258
 Australasia, data 382
 Australian Desert 383
 Autoimmune disorders 260
 Autografts 250, 251
 Autotrophs 399
 algae 134
 energy flows 170
 plants 148
 Autumn 271
 Autumn equinox 271, 500
 Aves 133
 Avocet 165
 Avogadro's number 73
 Axe, wedge 26
 Axes
 algebra 362
 Cartesian coordinates 366
 Axial plane, folds 277
 Axial skeleton 182
 Axial tilt 399
 Axilla 181
 Axillary fat pad 208
 Axillary lymph nodes 192
 Axillary nerve 186, 227
 Axioms, mathematics 558
 Axis 399
 gyroscopes 29
 Axis vertebra 183, 211
 Axles
 ball bearings 25
 wheels 27
 Axolotls 160, 161
 Axonal terminal 184, 187
 Axons
 association neuron 187
 motor neuron 184
 sensory neuron 187
 Ayurveda 237
- B**
 B cells, immune system 250, 260
 Babbage, Charles 337, 394
 Babies, pregnancy and childbirth 256-7
 Baboons 166
 energy requirements 580
 Babylonians
 astronomy 296, 297
 numbers 360
 Bacillariophyta 131
 Bacillus 134, 237
 Back 180
 muscles 210
 Backbone see Spine; Vertebral column
 Backwash, waves 287
 Bacteria 134, 400
 antibiotics 237
 antibodies 193
 carbon cycle 173
 chlorination of water 110
 classification 130, 131
 culture plates 258
 decomposition 173
 genetic engineering 262
 germ theory 237
 infections 258, 259
 lymphatic system 192
 nitrogen cycle 172
 prokaryotic cells 122
 structure 134
 Badgers, homes 380
 Baffin Island 382
 Bahada 281
 Baikal, Lake 383
 Baking powder 98
 Balard, Antoine-Jérôme 379
 Ball-and-socket joints 185
 Ball and stick models 68
 Ball bearings 25
 Balloons
 hot air 39
 weather 290
 Bandages 244
 Bank vole 170
 Bar charts 368, 369
 Barbs, cnidocytes 150
 Barium
 contrast X rays 100, 101, 241
 flame tests 116
 periodic table 74, 100
 Barium carbonate 105
 Barium sulfate 101
 Bark 142
 Barnacles 154
 classification 133
 Barnard, Christiana 237
 Barnard's Star 325
 Barometric pressure 293
 Barrages, tidal power 47
 Barred spiral galaxies 328
 Bartholin, Thomas 179, 394
 Basal disks, anemones 150
 Basal layer, epidermis 78
 Basaltic lava 275
 Bases 84, 400
 alkalis 84
 numbers 360
 salts 86
 sodium hydroxide 98
 Bases, genetics 400
 DNA 114, 115
 protein synthesis 124
 transcription 125
 translation 125
 Basic oxygen process, manufacture of steel 102, 105
 Basidiomycota 131, 137
 Basioccipital bone 206
 Bats 166, 167
 wings 129
 Batteries
 alkaline dry cells 96
 cars 17
 circuit symbol 339
 direct current 338
 electric circuit 43
 electric current 42
 history 336
 invention of 15, 66
 voltaic cells 96, 97
 Bayliss, William Maddock 179, 394
 Bays, coastlines 286, 287
 Beaches 286, 287
 Beadlet anemone 150
 Beaks
 birds 164
 evolution 128
 octopuses 153
 tortoises 162
 wading birds 165
 Beardmore Glacier 383
 Bearings
 ball bearings 25
 gyroscopes 29
 Bears, energy requirements 380
 Beaufort scale, winds 383
 Beaumont, William 179, 394
 Bedbugs, lifespan 380
 Bedding plane 286, 287
 Bedload, rivers 285
 Bees, pollination 146
 Beetles
 metamorphosis 156, 157
 wings 156
 Bell, Charles 179, 394
 Bell Laboratories 336, 337
 Bellatrix 324, 386
 Bently Trench 382
 Bering Sea, size 582
 Berkelium 75
 Bernard, Claude 121, 179, 394
 Berries, food chains 170
 Berry, Clifford 337
 Beryllium 100
 neutron detectors 15
 periodic table 74
 Bessel, Friedrich Wilhelm 296, 394
 Beta decay 58, 400
 Beta Pictoris 389
 Betelgeuse 324, 325, 386, 389
 Bethe, Hans Albrecht 297, 394
 Big Dipper constellation 385
 Bicipital aponeurosis 226, 228
 Bicuspid valve 191
 Bicycles 27
 Big Bang 297, 332-3
 Big Crunch 332, 333
 Big toe 232
 Bile 400
 digestion 196, 216, 217
 "humors" 256
 Bile duct 197, 216, 217
 Billion 377
 Bills
 duck-billed platypus 167
 see also Beaks
 Binary 400
 Binary addition 400
 Binary numbers 360, 376
 computer networks 354
 computers 337, 352
 logic gates 370
 Binary stars 324, 325
 Binding agents, tablets 254
 Binoculars
 lenses 52
 total internal reflection 52
 Binomial classification 11
 Biochemicals 400
 genetic engineering 262
 research 258
 Biochemistry 115
 history 67, 120, 121
 Biodiversity 174, 400
 Bioengineering 252-3
 biology 120-67
 history 120-1
 Biomass 170
 Biomes 168
 Bionic body parts 252-5
 Biopsy forceps 248
 Biosphere 168, 400
 natural cycles 172-3
 Bipolar transistors 348, 349
 Biquadratic curves 363
 Bird of Paradise constellation 388
 Birds 164-5
 birds of prey 165
 cladistics 133
 classification 133
 endangered species 175
 evolution 128, 269
 food webs 171
 tagging 175
 Bird's foot deltas 285
 Birth 257
 Bishop pine 141
 Bismuth 75
 Bison 175
 Bits
 computer networks 354
 computers 352
 Bitumen 113
 Bivalves 153
 Bivalvia 132, 152
 Bjerknes, Vilhelm 267, 394
 Black bile, "humors" 236
 Black bread mold, classification 131
 Black holes 350-1
 Big Crunch 333
 formation 326, 327, 330
 telescopes 299
 wormholes 331
 Black Sea 382
 Blackberries 147
 Bladder
 amphibians 160
 female 199, 224
 human body 198, 217, 220, 221
 lizards 162
 male 199, 222, 223

- mammals 166
 Blast furnaces 105
 Bleach
 formula 379
 sodium chlorate 110, 111
 Blind spot, eyes 205
 Blink comparators 300, 301
 Block and tackle 26
 Blood 400
 amphibians 160
 annelid worms 152
 blood groups 237
 cross-matching 251
 crustaceans 154
 DNA fingerprinting 265
 functions 191
 hemoglobin 115
 hemophilia 263
 heart-lung machines 247
 "humors" 256
 immunization 261
 insects 156
 liver and 217
 lizards 162
 malaria 259
 mammals 166
 manufacture of blood cells 182
 red blood cells 114, 191
 structure 191
 transfusions 257, 251
 white blood cells 191, 250
 see also Circulatory system
 Blood pressure,
 measuring 259, 244
 Blood tests, pregnancy 256
 Blood vessels 190-1, 400
 magnetic resonance imaging (MRI) 242
 mast cells 261
 microsurgery 248
 vascular grafts 252, 253
 Blue-green algae 134
 Blue light
 additive process 51
 color vision 50
 photons 48
 subtractive process 51
 white light spectrum 49
 Blue pigments, paper chromatography 70
 Blueshift, Dippler 501
 Boa constrictors 163
 lifespan 380
 Body fluids, diagnosis 259
 Body parts, artificial 252-3
 Body temperature
 amphibians 160
 birds 164
 mammals 166
 measuring 259
 reptiles 162
 Bohr, Niels 15
 Boiling point 52, 379
 Boj Bulok 383
 Bolus of food 196, 197
 Bomb calorimeters 170
 Bonds
 angles 68
 atoms 67, 78-9
 carbon atoms 114
 covalent 78-9
 hydrocarbons 112
 hydrogen bonding 78, 79
 ionic 78
 molecular models 68
 organic chemistry 112
 surface catalysis 88
 Bone marrow 182
 transplants 250, 251
 Bone saws 246
 bonesetting 178
 Bones 49, 182-5
 ear 205
 emergency care 245
 female pelvic region 224, 225
 foot 252
 fossils 128, 129
 grafts 251
 hand 228, 229
 joints 185
 lower leg 252, 253
 male pelvic region 222, 223
 muscles 184
 neck 204
 nose 205
 pectoral girdle 227
 pinning 253
 shoulder 226, 227
 skull 204, 206
 spine 211
 structure 182
 surgery 247
 thigh 230
 thorax 212, 215
 see also Skeleton
 Bony fish 159
 anatomy 158
 classification 153
 sharks 159
 Book lungs, arachnids 155
 Boole, George 357, 394
 Boolean algebra 357, 359, 371
 Boites constellation 386, 389
 Boreal forest, life zones 168
 Borneo 382
 Boron
 atoms 72
 doping a semiconductor 346
 periodic table 75
 Bosons, particle physics 60
 Botany, history 120
 Bottlenose dolphin 167
 Boulder beaches 287
 Bourdon gauge 39
 Bowman's capsule 198
 Box jellies,
 classification 132
 Boyer, Herbert Wayne 121, 394
 Boyle, Robert 67, 394
The Sceptical Chymist 66
 Boyle's Law 58
 formula 378
 Boyoma Falls 385
 Braces, immobilizing joints 245
 Brachial plexus 186, 202, 205, 226
 Brachiopoda 153
 Bracts, flowers 144
 Brahe, Tycho 296, 297, 394
 Braiding, rivers 285
 Brain
 amphibians 160
 angiography 241
 arachnids 155
 birds 164
 coronal section 207
 Creutzfeld-Jacob disease 259, 262
 crustaceans 154
 fetal tissue transplants 251
 fish 158
 human body 186-7, 200
 inferior view 207
 insects 156
 lateral view 206
 lizards 162
 magnetic resonance imaging (MRI) 242
 mammals 166
 microsurgery 249
 positron emission tomography (PET) 242, 243
 research 179
 sagittal section 207
 superior view 207
 trepanning 236
 Brain stem 187, 188, 207
 Brakes
 cars 17
 friction 25
 Branchiopoda 153
 Brandt, Georg 379
 Brass, electroplating 97
Brassavola nodosa 145
 Bread
 raising agents 99
 yeasts 156
 Bread molds 136
 Breadboards, printed circuit boards 358
 Breakers, waves 287
 Breastbone see Sternum
 Breasts 180
 breast-feeding 208
 implants 253
 mammograms 241
 Breathalyzers 70
 Breathing
 amphibians 160
 crocodilians 163
 emergency care 245
 fish 158
 mammals 166
 medical diagnosis 238
 respiratory organs 194-5
 Bridge rectifiers 547
 Bright filament lamps 50
 Brine 98, 99
 Brittle stars 151
 classification 153
 Bromide, formula 379
 Bromine 110
 diffusion 58
 discovery of 379
 mass spectrometry 117
 melting and boiling points 379
 periodic table 75, 110
 photocatalysis 88
 Bronchi 194, 212
 left lower lobar (secondary) bronchus 213
 left principal (primary) bronchus 213, 215
 left upper lobar (secondary) bronchus 213
 right principal (primary) bronchus 213, 215
 segmental (tertiary) bronchus 195, 213
 Bronchial tree 213
 Bronchioles 194, 195, 213
 Bronchitis 381
 Bronchodilators 581
 Bronchomediastinal lymphatic trunk 192
 Bronchus see Bronchi
 Bronze 104, 105
 Brown algae,
 classification 150
 Brown seaweeds 138
 Brownian motion 16, 400
 Bryophyta 150, 138
 Bryozoa 153
 classification 153
 Bubble chambers 400
 cosmic rays 58
 particle accelerators 60
 Bubbles
 colors 54, 55
 surface tension 36
 Buccal cavity, birds 164
 Buccinum undatum 171
 Buckminsterfullerene 68, 104
 Budding, asexual reproduction 126
 Buds
 adventitious 126
 apical 141, 142
 flowering plants 142, 145
Bufo marinus 175
 Buildings 21
 Bulb of penis 223
 Bulbourethral gland 199, 222
 Bulking agents, tablets 254
 Bull constellation 386
 Bunsen, Robert Wilhelm 67, 394
 Bunsen burners, flame tests 116
 Burnell, Jocelyn Bell 297, 394
 Burning 52, 400
 activation energy 90
 chemical reaction 85
 hydrocarbons 112
 magnesium 77
 oxidation 82
 oxygen 66, 67, 108
 Buses, computers 353
 Bushels 376
 But-1-ene 112
 But-1-yne 112
 But-2-ene 112
 But-2-yne 112
 Butane
 atoms 112
 fractional distillation 115
 Butene, isomers 112
 Butterflies 157
 Buttes 280
 Butyne, isomers 112
 Bytes, computers 352
 Cables, computer networks 354
 Cacti 145
 Cadmium 75
Caecilia tentaculata 161
 Caecilians 160, 161
 Caelum constellation 386
 Cecum 196, 197, 216, 217, 218
 ileocecal junction 219
 Cesarean section 256, 400
 Cesium 98
 discovery of 67
 periodic table 74
 Caiman crocodilus 163
 Caimans 162
 spectacled 163
 Calcaneal tuberosity 232
 Calcareous 400
 Calcareous ossicles,
 echinoderms 150
 Calcareous shells,
 mollusks 152
 Calcite 279
 Calcitonin 189
 Calcium 400
 compounds 100
 in Earth's crust 379
 flame tests 116
 formula 379
 glass 105
 hard water 100
 ions 100
 mortar 101
 periodic table 74, 100
 reactivity 94
 sea water 288
 spectral absorption lines 301
 Calcium carbide 112
 Calcium carbonate
 formula 379
 glass 105
 hard water 100
 limestone 87
 manufacture of steel 105
 marble 81
 mortar 101
 Calcium chloride 77, 90
 Calcium
 hydrogencarbonate 100
 Calcium hydroxide
 ammonia production 106, 107
 mortar 101
 preparation of ethyne 112
 testing for carbon dioxide 85
 testing for carbonates 116
 calcium oxide 107
 Calcium sulfate
 hemihydrate 379
 Calculators
 invention of 357, 358
 LEDs 347
 Calculus 359
 Caldera volcanoes 275
 Calf muscles 180
 California, San Andreas Fault 276
 Californium 75
 Caliper units 25
 Callisto 316
 Caloric 14
 Calorimeters 170
 Caloris basin, Mercury 312
 Calyx, flowers 143
 Cambrian layer 149
 Cambrian period 268, 269
 Camcorders 357
 Camouflage
 birds 165
 peppered moth evolution 128
 rays (fish) 159
 snakes 163
 toads 161
 Canada, ice sheets 285
 Cancellous bone 182
 Cancer
 computerized tomography 241
 magnetic resonance imaging (MRI) 242
 T cells and 250
 Cancer constellation 386, 389
 Cancer pagurus 171
 Candela, SI units 377
 Candida fungi 136
 classification 151
 infections 259
 Candle wax
 combustion 83
 fractional distillation 113
 melting point 78
 Cane beetle 175
 Cane toad 175

- Canes Venatici constellation 386, 389
- Canine teeth
carnivores 166
herbivores 166
human 196
- Canis Major constellation 388, 389
- Canis Minor constellation 386, 389
- Canopus 329, 389
- Canopy 400
- Cantor, Georg Ferdinand Ludwig Philip 359, 394
- Canyons 281
on Mars 314, 315
submarine 288
- Capacitance 400
capacitors 342
multimeters 359
- Capacitors 342-3
computers 352
electronic circuits 358
integrated circuits 350
rectifiers 347
tuned circuits 345
- Capacity
conversion tables 377
measurements 376
- Capella 386, 389
- Capillaries 190, 400
bone 182
discovery of 179
lungs 194, 195
lymphatic 192, 193
pulmonary circulation 191
small intestine 197
systemic circulation 191
- Capillary action 36, 400
- Capitulum flowers 144
- Capricorn constellation 387
- Capricornus constellation 388
- Caps, gilled mushrooms 137
- Capsid, viruses 134
- Capsules
drugs 255
kidney 198
lymph nodes 193
mosses 138
spleen 195
- Caput constellation 386
- Carapace
crustaceans 154
tortoises 162
- Carbohydrates 400
carbon cycle 173
organic chemistry 114
oxygen cycle 173
photosynthesis 148
- Carbolic acid 257
- Carbon 104
allotropes 104
alloys 102
atoms 114
carbon cycle 173
- catalytic cracking of oil 113
- combustion 83
- compounds 68
- decomposition 134
- dehydration of sucrose 92
- discovery of 379
- DNA 115
- ethanol 68
- extraction of iron 77
- fatty acids 99
- fractional distillation 115
- fullerenes 104
- hydrocarbons 112
- melting and boiling points 379
- molecular structure of diamond 104
- organic chemistry 104, 112, 114
- periodic table 75, 104
- photosynthesis 148
- radiocarbon dating 268
- stellar life cycles 327
- Carbon dioxide 400
acid on a hydrogencarbonate 85
acid on limestone 87
atmosphere 290
carbon cycle 173
carbonated drinks 89
catalytic converters 89
chemical reactions 81 and combustion 83
in comets 322
decomposition 173
dry ice 90
extraction of iron 77
fermentation 89, 136
gills 158
global warming 174
on Mars 315
and mortar 101
photosynthesis 100, 148
respiration 124
respiratory system 194, 195
sodium hydrogencarbonate 99
testing for carbonates 116
on Venus 315
- Carbon granules, resistors 340
- Carbon monoxide 89
- Carbonated drinks 89
- Carbonates 85
formula 379
rocks 87
salts 86
testing for 116
- Carboniferous period 269
- Carcharinus melanopterus* 159
- Cardia of stomach 220
- Cardiac notch 194
- Cardiac sphincter 197
- Cardiologists 240
- Cardiology 381
- Cardiovascular system 190-1
- Cards, computers 353
- Caribbean plate 272
- Caribbean Sea, size 382
- Caries 381
- Carina 215
- Carnivora 130
- Carnivorous 400
amphibians 160
classification 130
crocodilians 163
energy flow 170
food chains 170
plants 145
snakes 163
teeth 166
- Carpals 182, 228
joints 183
- Carpels 400
flowers 143
succulent fruits 147
- Carpus 228
- Carrying capacity, ecosystems 168, 169
- Cars
brakes 17
catalytic converters 88, 89
energy transfer 17
engines 22
- Cartesian coordinates 366
- Cartilage
fish 158
hands 229
human skeleton 182
intervertebral discs 183
larynx 194, 215
nose 203
ribs 215
surgery 247
trachea 204, 213, 215
X-ray imaging 241
- Cartilaginous fish 158, 159, 400
classification 133
- Caspian Sea 382, 383
- Cassini division 308
- Cassiopeia constellation 386
- Castanea sativa 146
- Castor 386, 389
- Casualties, emergency care 244-5
- Cat fleas 157
- Cat reactions (catabolism) 124, 400
- Catalysts 88-9, 400
catalytic cracking of oil 113
- cell functions 124
- CFCs 111
- copper oxide 102
- decomposition of hydrogen peroxide 108
- Haber process 107
- hydrocarbons 112
- Catalytic converters 88, 89
- Cataphyll 147
- Cataracts, eyes 257, 252, 381, 400
- Cataras del Iguazu Falls 383
- Caterpillars 157
- Catheters, aspirators 244
- Cathode-ray tubes (CRTs) 400
electrons 56, 57
history 336
oscillographs 31
oscilloscopes 339
television 56, 57
- Cathodes 400
Downs Process 77
electrolytic cells 96
electroplating 97
- Cathodic protection 95
- Cations 400
acid salts 87
activity series 94
alkali metals 98
alkaline earth metals 100
ammonium ion 106
chemical reactions 80
electrodes 97
flame tests 116
metals 76
salts 86
testing for 117
- Catkins 146
- Cats
classification 130
energy requirements 380
Cattle, gestation period 380
- Caudal fins, fish 158, 159
- Caudal vertebrae, mammals 166
- Caudate nucleus 207
- Cautery loops, endoscopes 248
- Cavendish, Henry 67, 379, 394
- Caverns 281
- Caves
ice 282
limestone 281
sea 286, 287
sizes 383
- CBR see Cosmic background radiation
- Cedars 140
- Celcus 257
- Celestial sphere 300
- Celiac trunk 218, 220, 221
- Cell, unit (crystals) 34
- Cell membrane
blood cells 191
receptor sites 254
- Cells 401
animal 122
biochemistry 121
blood 191
chromosome abnormalities 263
- cnidocytes 150
discovery of 120, 179
division 126-7, 263
energy 122
epidermis 181
eukaryotic 122, 134
functions 124-5
fungi 136
genetic cloning 263
immune system 260-1
Krebs cycle 121
meiosis 127
microorganisms 134-5
mitosis 126
organelles 123
plant 122, 123
prokaryotic 122, 134
red blood cells 114
respiratory system 195
sex 126, 199
structure 122-3
viral infections 258
walls 123, 134
see also Electrochemical cells
- Cellulose, plant cells 123
- Celsius scale 32, 376, 401
- Celsius 394
- Cement
mixture 70
mortar 100
teeth 197
- Cenozoic era 269
- Centaur constellation 388, 389
- Centaurus constellation 386, 388, 389
- Centigrade scale see Celsius scale
- Centiliters 376
- Centimeters 376, 377
- Centipedes 154, 156, 157
classification 132
speed 380
- Central nervous system 184, 186-7, 401
anesthetics 247
magnetic resonance imaging (MRI) 242
- Central processing units (CPUs), 352, 353
logic gates 370
- Center of gravity 401
point of suspension 21
- Centripetal force 28-9, 401
formula 378
particle accelerators 61
- Centrum, vertebrae 211
- Cephalochordata 133
- Cephalopoda 132, 152
- Cephalopods 153
- Cephalothorax
arachnids 155
chelicerates 154
crustaceans 154
- Cepheid variable stars 325
- Cepheus constellation 386
- Cerata, lettuce slugs 153
- Cerebellum 187, 188, 207
magnetic resonance imaging (MRI) 242
- Cerebral cortex 187, 207
- Cerebral ganglion
annelid worms 152
gastropods 153
- Cerebral hemispheres 187, 206, 207
- Cerebrospinal fluid 186, 207
- Cerebrum 186, 187, 188, 206
magnetic resonance imaging (MRI) 242
- Cerium 74
- CERN (Conseil Européen pour la Recherche Nucléaire) 401
- Large Hadron Collider 60, 61
- Cervical canal 199, 224
- Cervical lymph nodes 192
- Cervical nerves 186
- Cervical plexus 186, 202
- Cervical vertebrae
human anatomy 182, 183, 200, 211
mammals 166
- Cervix 199, 224, 225
diagnosis 239
- Cestoda 132
- Cetacea 167
- Cetus constellation 387, 388
- CFCs (chlorofluorocarbons) 401
and ozone layer 110, 111, 174
- Chaetognatha 133
- Chain reactions 59, 401
- Chainwheel 27
- Chalk, formula 379
- Challenger Deep 382
- Chamaeleon constellation 388
- Chameleons 163
- Chang Heng 266, 267
- Chang Jiang River 383
- Chaos theory 15, 358, 359, 372-3
- Charcoal 104
- Charge see Electric charge
- Charged atoms 40
- Charged particles
current 96
lightning 292
magnetosphere 271
pulsars 330
- Charging capacitors 342
- Charioteer constellation 386
- Charles' Law 38
experiment 39
formula 378
- Charon 321

- Charts, statistics 368, 369
- Cheetahs 167
- Chela, arachnids 155
- Chelicera, spiders 155
- Chelicerae
- arachnids 155
 - chelicerates 154
- Chelicerata 133, 154
- Chelicerates 154, 156
- classification 133
- Chelon labrosus 171
- Chemical analysis
- 70, 116-17
- Chemical balances 73
- Chemical energy 17
- Chemical reactions
- 80-1, 401
 - acid-base 84
 - atoms 68
 - catalysts 88-9
 - combustion 83, 108
 - conservation of mass 81
 - decomposition 69, 80
 - displacement 94-5
 - electrochemistry 96
 - endothermic 90
 - energy changes 90
 - exothermic 76, 77, 85, 90
 - extraction of metals 77
 - iron sulfide 69
 - metabolism 124
 - oxidation 82-3
 - phlogiston theory 66, 67
 - reaction rates 80, 81
 - redox 77, 82-3
 - reduction 82-3
 - reversible 103, 107
 - thermite 91
 - titration 85
- Chemical weathering
- 280, 281
- Chemicals
- pollution 174
 - symbols 75
- Chemistry 6, 64-117
- acids and bases 84-5
 - activity series 94-5
 - alkali metals 98-9
 - alkaline earth metals 100-1
 - atoms and molecules 72-3
 - bonds between
 - atoms 78-9
 - carbon, silicon
 - and tin 104-5
 - catalysts 88-9
 - chemical analysis 116-17
 - data 379
 - electrochemistry 96-7
 - elements and
 - compounds 68-9
 - halogens 110-11
 - heat 90-1
 - history 66-7
 - laboratories 10
 - metals and nonmetals 76-7
 - mixtures 70-1
 - nitrogen and
 - phosphorus 106-7
 - organic chemistry 112-15
 - oxidation and
 - reduction 82-3
 - oxygen and sulfur 108-9
 - periodic table 74-5
 - reactions 80-1
 - salts 86-7
 - transition metals 102-3
 - water 92-3
- Chemotherapy 237
- Cherrapunji 382
- Chest see Thorax
- Chestnut, sweet 144, 146
- Chickens, eggs 164
- Chicks 164
- Chihuahuan Desert 383
- Childbirth 257
- Chilopoda 132
- Chimpanzees, limbs 129
- China
- astronomy 296, 297
 - chemistry 67
 - mathematics 358, 359
 - medicine 236
 - rivers 285
 - seismology 266
- Chips see Integrated circuits
- Chiropody 381
- Chiroptera 167
- Chitin 136, 401
- Chitons, classification 132
- Chloride
- chemical reactions 81
 - formation of sodium chloride 79
 - formula 379
 - salts 86
 - sea water 288
- Chlorine
- bleaching 111
 - CFCs 111
 - characteristics 76
 - chloroethene 115
 - compounds 110
 - concentrations 110
 - discovery of 379
 - Downs Process 77
 - gas 90, 110
 - halogen 110
 - macromolecules 76
 - mass spectrometry 117
 - periodic table 75, 110
 - preparation 110
 - sodium hydroxide 99
 - in water 110, 111
- Chlorine monoxide 111
- Chlorofluorocarbons see CFCs
- Chlorophyll 100
- chloroplasts 123
 - photosynthesis 148
- Chlorophyta 130, 135
- Chloroplasts 123, 401
- euglenoids 135
 - lettuce slugs 153
 - photosynthesis 122, 148
 - structure 148
- Cho Oyu 383
- Choanocytes, sponges 150
- Cholesterol plaque 252, 401
- Chondrichthyes 133, 158
- Chondrites 270
- Chordata 130, 133
- Chorion, birds' eggs 164
- Chorionic villus sampling 256
- Chromate ion 103
- Chromatic aberration 401
- Chromatids 126, 127
- Chromatography 116, 401
- gas chromatography 70
 - paper chromatography 70
 - separating mixtures 70
- Chromium
- alloys 102
 - discovery of 379
 - oxidation number 102, 103
 - oxides 102
 - periodic table 74
- Chromosomes 401
- abnormalities 263
 - antenatal screening 256
 - cell functions 124
 - genetic engineering 262
 - meiosis 127
 - mitosis 126
- Chromosphere, Sun 307
- Chrysaora quinquecirrha* 150
- Chrysophyta 131
- Cilia
- ciliates 135
 - fan worms 152
- Ciliates 134, 135
- classification 131
- Ciliophora 131
- Cinder cones, volcanoes 275
- Circles
- algebra 362
 - area and volume 393
 - cones 365
 - geometry 364
 - hemispheres 365
 - set theory 370
- Circuit boards 338
- Circuit breakers 46
- Circuit diagrams 338
- Circuits
- electronic 338-9
 - integrated 350-1
 - logic gates 370
 - see also Electric circuits
- Circular motion 28-9
- Circular waves 54
- Circulatory system 401
- human body 190-1
 - mammals 166
 - research 179
- Circumference, circles 364
- Circumferentor 267
- Circumvallate papilla 205
- Cirques 282, 283
- Cirripedia 133
- Cirrocumulus clouds 292
- Cirrostratus clouds 292
- Cirrus clouds 292
- Cisterna chyli 192
- CJD see Creutzfeldt-Jacob disease
- Clades, classification 133
- Cladistics 132, 133
- Cladograms 133
- Clams
- classification 132
 - lifespan 380
- Classes, classification 130, 133
- Classical physics 62
- Classification 130-3
- history of 120
 - scientific names 11
 - species 130-3
- Clavicle
- birds 164
 - human body 180, 182, 205, 209, 214, 226
 - joints 183
 - mammals 166
 - pectoral girdle 227
- Clavus, Moon 311
- Clawed toad 160
- Claws
- birds 164
 - cheetahs 167
 - crocodilians 163
 - lizards 163
 - spiders 155
- Cleaner wrasse 169
- Cleft palate 263
- Cliffs 286, 287
- Climate
- atmospheric science 266
 - geological time 269
 - global warming 174
 - ocean currents 288, 289
- Clinical 401
- Clinical thermometers 239
- Clitoris 224, 225
- Cloaca
- amphibians 160
 - birds 164
 - fish 158
 - lizards 162
- Clocks
- LEDs 347
 - pendulums 14
- Clockwise moment 21
- Clones, genes 262
- Cloning 263
- Cloud chambers 58, 401
- Clouds
- hurricanes 293
 - on Jupiter 316, 317
 - on Mars 315
 - precipitation 292
 - solar energy reflection 290
 - types of 292
 - water cycle 172, 267
- Clownfish 169
- Club mosses, classification 131
- Clusters
- galaxies 328
 - stars 324
- CMS detectors 61
- Cnidaria 132
- Cnidarians 150
- classification 132
 - reproduction 126
- Cnidocil 150
- Cnidocytes 150
- Coal
- formation of 269
 - power stations 46
- Coastal food webs 171
- Coastlines 286-7
- Coatings, tablets 254
- Coaxial cables 354
- Cobalt
- chemical reactions 81
 - discovery of 379
 - periodic table 74
- Cobalt chloride 73
- COBE (Cosmic Microwave Background Explorer) 297
- Cobras 163
- Cocaine 254
- Coccus bacteria 134
- Coccygeal nerve 186
- Coccygeal vertebrae 211
- Coccyx 182, 183
- female pelvic region 224, 225
 - male pelvic region 222, 223
 - vertebrae 211
- Cochlea 179, 203
- Cockcroft, John Douglas 15, 394
- Cocoons, spiders 155
- Cocos plate 272
- Cod, Atlantic 158
- Codons, genes 124, 125
- Coelom, worms 152
- Cohen, Seymour Stanley 121, 394
- Cohesive forces 36, 401
- Coils
- electric motors 45
 - electromagnets 44, 45
 - generators 46
 - inductors 344
 - solenoids 45
 - televisions 57
- Coitus 199
- Cold 32
- four-elements theory 66
 - receptors 181
- Cold fronts 293
- Colic flexure 218
- Colima 383
- Collagen, tendons 184
- Collar bone see Clavicle
- Collectors, transistors 348
- Collisions 60
- Colloids 70, 401
- Colon
- ascending colon 196, 197, 216, 217, 218, 219
 - descending colon 196, 197, 216, 217, 218, 219
 - function 197
 - mammals 166
 - sigmoid colon 197, 218, 219, 220, 225, 224
 - transverse colon 196, 197, 216, 217, 218, 219
- Colonies, tree wasps 157
- Color 50-1
- additive process 50, 51
 - alkaline earth metals 101
 - bleaching 111
 - chemical analysis 117
 - chlorine test kit 111
 - destructive interference 55
 - fireworks 101
 - flame tests 116
 - fluorescence 56
 - glass 105
 - insect wings 156
 - metals 76
 - paper chromatography 70
 - primary colors 50
 - secondary colors 51
 - soap bubbles 54, 55
 - stars 325
 - subtractive process 51
 - transition metals 102
- Color blindness 263
- tests 239
- Columba constellation 386, 388, 389
- Coma Berenices constellation 386, 389
- Comb jellies, classification 133
- Combustion reaction 83
- hydrocarbons 112
 - oxygen 108
- Comet Shoemaker-Levy 303, 316, 317
- Comets 322-3
- data 385
 - impact craters 308, 309
 - solar system 304
 - space probes 302
- Commensalism 16
- Common fractions 360, 361
- Common peroneal nerve 186
- Commonwealth Bay 382
- Communication, scientific ideas 11
- Communities, ecology 168
- Commutator 45
- Compact bone 182
- Compact discs (CDs) 337
- Comparitors 111
- Compasses
- electromagnetism

- affecting needle 44
magnetism 41
Complex ions 401
chlorine in water 111
reactions 81
Complex numbers 401
Component, weight 20
Components 401
Composite flowers 144
Composite volcanoes 275
Compound eyes 156, 401
Compound leaves 144
Compounds 68-9, 70, 401
anhydrous 92
bonds 78
calcium 100
chemical analysis 116
chlorine 110
copper 102
decomposition 69
dehydrating agents 92
efflorescent 92, 95
exothermic reactions 90
formulae 379
hygroscopic 92, 95
macromolecules 76
metals 76
minerals 278
nitrogen 106
organic chemistry 112
oxidation number 82
relative molecular mass (RMM) 72
salts 86
sodium 98
sp³ hybrid orbitals 104
sulfur 108
transition metals 102
water and 92
Compression 401
solids 34
sound waves 31
springs 30
Computer-assisted tomography (CAT) 179, 237, 240, 241
Computers 7, 352-5
data 390-1
drug development 254
fractals 372
generations 391
history 356-7
integrated circuits 350
logic theory 370
medical imaging 240, 242
microsurgery 249
networks 354-5
printed circuit boards 358
supercomputers 8
virtual-reality surgery 249
Concave 401
lenses 53
mirrors 53
Concentrations 72, 401
chemical reactions 80, 81
chlorine 110
solutions 73
titration 85
Concha 205
Conclusions, logic 371
Condensation 32
clouds 292
fractional distillation 113
Condenser jackets 71
Conduction 32
Conductive 401
Conductors
electric circuits 42
electrochemistry 96
metal 76
Condylactis 150
Cones (botany) 402
conifers 140, 141
cycads 140
gnetophytes 140
gymnosperms 140
Cones (eyes) 402
color vision 50
Cones (mathematics) 402
area and volume 393
geometry 365, 392
Cones, volcanoes 275
Congo, River 383
Coniferophyta 151
Conifers 140, 269
acid rain 174
classification 151
Conjunctiva 205
Conjunctivitis 381
Connections, circuit symbol 359
Connective tissue
mast cells 261
tendons 184
trachea 215
Conservation, endangered animals 175
Conservation of energy 17
Conservation of mass 81
Constants 402
algebra 362
Constellations 524
history of astronomy 296
Northern sky 586-7
Southern sky 588-9
Constrictors 163
Constructive breakers 287
Constructive
interference 54, 402
Constructive margins, plate tectonics 273
Contact lenses 239
Contact potential, diodes 347
Continental crust 288
fold mountains 277
Continental drift 267
Continental glaciers 282
Continental shelf 279, 288
Continental slope 288
Continents
data 382
formation of 268, 273
ice ages 283
plate tectonics 267, 272-3
Contour feathers 164
Contractile vacuoles
amoebas 135
euglenoids 135
Contractions, childbirth 256, 257
Contrast X rays 241
Convection 402
atmosphere 290
Convection currents, plate tectonics 272
Convective zone, Sun 307
Conventional current 42
Converge 402
light rays 52
Convex 402
lenses 52
mirrors 53
Cooksonia 268
Cooling towers 59
Coordinate geometry 358-9, 364, 366-7
Coordinates, astronomy 300
Copernicus, Nicolaus 9, 296, 297, 394
Copernicus crater, Moon 311
Copper 76
bronze 105
compounds 102
discovery of 67
displacement reactions 94-5
electrodes 97
electroplating 97
formula 379
molar mass 73
oxidation 82
periodic table 75
preparation of nitrogen 106
printed circuit boards 358
reactivity 94
transition metals 102
Copper carbonate 102
Copper chloride 102
Copper hydroxide 102
Copper nitrate 95, 102
Copper oxide 86, 102
Copper sulfate
anhydrous 83
displacement reactions 94
formation 86
water of crystallization 92
Coprates Chasma, Mars 315
Cor Caroli 586, 589
Coracoid process 227
Coral reefs
atolls 289
primary production 580
Corals 150
classification 132
Core
Earth 270, 271
Mars 314
Moon 311
Neptune 320
Sun 307
Venus 313
Coriolis, Gaspard 289
Coriolis effect 289, 291
Corkscrews 26
Cornea 203, 205
transplants 250, 251
Corners 29
Corniculate cartilage 194, 215
Cornified layer 181
Corolla, flowers 143
Corona, penicillin 223
Corona, Sun 307
Corona Australis constellation 587, 588
Corona Borealis constellation 589
Coronary ligament of liver 217
Coronary sinus 213
Coronoid process 206
Corpus callosum 187, 207
Corpus cavernosum 223
Corpus spongiosum 222, 223
Corries 282
Corrosion 94, 95
Cortex
adrenal glands 189
cerebral 187, 207
herbaceous shoots 149
kidneys 198
roots 149
woody flowering plants 142
Cortical sinus, lymph nodes 193
Corundum 279
Corvus constellation 386, 388
Cosine, trigonometry 367
Cosmic background radiation (CBR) 402
Big Bang 297, 332, 333
ripples 333
Cosmic rays 58
Cosmology 332-3
Big Bang theory 297
Costadiaphragmatic recess 220
Costal cartilage 215
Costs of science 10-11
Cotopaxi 383
Cotyledons 147, 402
conifers 141
Coulombs 377
Counting numbers 360
Courtship, newts 161
Covalent bonds 78-9, 402
discovery of 67
ethyne 112
Coxa 182, 183
Crab constellation 386
Crabs 154
classification 132, 133
food webs 171
Cracking, hydrocarbons 112, 115
Crane constellation 388
Cranial bones 206
Cranial nerves 186, 207
Cranium
fish 158
human skeleton 200, 206
Crater constellation 386, 388
Craters
on asteroids 323
on Mars 315
on Mercury 312
on Moon 310, 311, 323
planets 308, 309
Creams, drugs 255
Creation myths 8
Creationism 128
Cremasteric fascia 222
Crest, folds 277
Cretaceous period 269
Creutzfeldt-Jacob disease (CJD) 259, 262
Crevasses 282
Crick, Francis 121, 394
Cricoid cartilage 194, 204
Cricothyroid ligament 194
Cricotracheal ligament 194
Crinoid 268
Crinoidea 133
Critical angle, total internal reflection 52, 402
Crocodile clips 19
Crocodiles 162
cladistics 133
Crocodilians 162, 163
Crookes, William 337, 394
"Crookes tube" 337
Crop
annelid worms 152
birds 164
gastropods 153
Cross-sectional area 35
Crow constellation 388
Crown, teeth 197
Crown wheels 17
Crude oil 112, 115
Crust
Mars 314
Moon 311
Venus 313
Crust (Earth's) 270
earthquakes and volcanoes 274-5
elements 379
faults and folds 276-7
plate tectonics 272-3
Crustacea 133, 154
Crustaceans 154, 156, 402
classification 133
evolution 268
Crux-Centaurus Arm, Milky Way Galaxy 329
Crux constellation 388, 389
Cryogenic units 402
Crystal lattices 34, 402
Crystallization, states of matter 16, 32
Crystals 402
cubic system 34
external features 34
hexagonal system 35
identification 266
macromolecules 79
minerals 278
monoclinic system 35
orthorhombic system 34
particles 16
rhombic sulfur 109
semiconductors 346
silicon 104
solids 34
sucrose 114
tetragonal system 34
triclinic system 35
trigonal system 35
unit cells 34
water of crystallization 92, 93
X-ray crystallography 67
CT scanning see Computerized tomography scanning
Ctenocephalides felis 157
Ctenophora 133
Cubes, geometry 364, 392
Cubic curves 363
Cubic numbers 360, 361
algebra 362
Cubic system, solids 34
Cubical fossa 180
Cubozoa 132
Cuesta 280
Cultivated land, primary production 380
Culture plates 258
Cumulonimbus clouds 292
Cumulus clouds 292
Cuneiform cartilage 215
Cup constellation 388
Cuquenén Falls 383
Curium 75
Current see Electric current
Currents, ocean 289
coastlines 286
plate tectonics 272
Curves
distribution 368, 369
elliptic geometry 365
geometry 364
hyperbolic geometry 365
polynomial functions 363
Cuscuta europaea 169

- Cuspede deltas 285
 Cuticle
 arthropods 154, 156
 insect wings 156
 leaves 149
 nails 181
 pine needles 141
 Cuttlefish 155
 Cuvier, Georges 120, 121, 594
 Cwms 282
 Cyan 51
 Cyanobacteria 134
 lichens 157
 Cycadophyta 151
 Cycads 140
 classification 151
Cycas revoluta 140
 Cyclones 291
 tropical 295
 Cyclosporin 250, 254
 Cyclostomata 158
 Cygnus constellation 386, 388
 Cylinders
 area and volume 393
 geometry 392
 Cypresses 140
 Cystic duct 216
 Cystic fibrosis 257
 Cysts, ovarian 248
 Cytology brushes 259
 endoscopes 248
 Cytoplasm 402
 amoebas 155
 animal cells 122
 mast cells 261
 mitosis 126
 phagocytes 260
 plant cells 125
 protein synthesis 124
 Cytosine 115
 Cytosome 155
- D**
 D-block, periodic table 102
 D-orbitals 72
 Dalton, John 15, 67, 594
 Dark nebulae 526
 Darwin, Charles 120-1, 128, 266, 289, 594
 Data 374-95
 graphs 18
 interpreting 19
 Dating, radiocarbon 268
 Daughter cells
 asexual reproduction 136
 meiosis 127
 mitosis 126
 Daughter nucleus,
 nuclear fission 59
 Davy, Humphrey 67, 394
 DC see Direct current
 De Forest, Lee 336, 337, 396
 Dead Sea 382
 Death Valley 382
 Decaliters 376
 Decay
 alpha decay 58
 beta decay 58
 December solstice 271
 Deciliters 376
 Decimal fractions 360
 Decimal numbers 361
 mathematics 358, 359
 Declination, astronomy 300
 Decomposition 402
 carbon cycle 175
 catalytic cracking
 of oil 113
 chemical reaction 80
 double decomposition
 reaction 117
 electrolytic 96
 fermentation 89
 flame tests 116
 mercury oxide 69
 natural cycles 175
 natural cycle 172
 preparation of oxygen 108
 sodium
 hydrogencarbonate 99
 soil bacteria 154
 Decongestants 381
 Deduction 8
 Deep muscles 184, 402
 forearm and hand 229
 head and neck 200, 203
 shoulder and upper
 arm 226, 227
 thighs 231
 trunk 209, 210
 Defibrillators 244
 Deflation hollows,
 erosion 280
 Deflection 57
 Degree Celsius 32
 Degree Fahrenheit 32
 Degree Kelvin 32
 Degrees, angles 366
 Dehydrating agents 92, 402
 Demos 314
 Delphinus constellation 387, 388
 Deltas 279, 284, 285
 Democritus 15, 67, 395
 Denali 382
 Denary system,
 numbers 360
 Dendrites 187
 Deneb 325, 387, 388
 Deneb Algedi 387, 388
 Deneb Kaitos 387, 388
 Denebola 386, 389
 Denitrifying bacteria 172
 Denman Glacier 385
 Denominator 361
 Density 402
 neutron stars 330
 solids 34
 universe 332, 333
 Dentine 197
 Dentition 402
 see also Teeth
 Deoxyribonucleic acid
 (DNA) 114, 115
 Depletion layer,
 semiconductors
 346, 347
 Deposition
 glacial 283
 reactivity 94
 Depot implants,
 drugs 255
 Depressions, weather 295
 Depth 37
 Depth of field 53
 Derived SI units 377
 Dermal denticles, fish 159
 Dermatology 381
 Dermis 181
 Descartes, René 14, 359, 395
 Descending colon 196, 197, 216, 217, 218, 219
 Deserts
 erosion 280
 life zones 168
 primary production 380
 sizes 385
 Desiccators 92, 95
 Desmid 135
 Destructive breakers 287
 Destructive interference
 54, 402
 Destructive margins,
 plate tectonics 275
 Detritivores 173
 Deuteromycota 151
 Devonian period 269
 Dhaulagiri 385
 Diabetes 260
 Diagnosis 258-9, 402
 endoscopes 248
 medical imaging 240-5
 Diagrams
 circuit 358
 scatter 368, 369
 Venn 370, 371
 Dialysis, kidney 251
 Diameter
 circles 364
 spheres 365
 1,6-diaminohexane 114
 Diamond
 carbon atoms 104
 hardness 279
 Diaphragm 212, 214, 215, 216, 217, 218, 220, 402
 breathing 194, 195
 central tendon 221
 costal portion 221
 left crus 221
 mammals 166
 right crus 221
 stethoscopes 238
 Diaphragm, pelvic 222
 Diaphragm, urogenital
 222, 225
 Diaphysis
- bone 182
 metacarpals 229
 Diastole 191
 Diastolic pressure, blood
 pressure 239
 Diatomic molecules 402
 electrolytic
 decomposition of
 water 96
 gases 110
 nitrogen monoxide 80
 oxygen 77, 80
 surface catalysis 88
 Diatoms 155
 classification 131
 Dichasial cyme flowers 144
 Dicotyledonous plants
 (dicots) 142
 classification 131
 leaves 145, 144
 Didinium 155
 Dielectric, capacitors
 342, 345, 403
 Diffraction 403
 electromagnetic
 radiation 48
 waves 54
 Diffraction gratings
 301, 405
 Diffusion 405
 gases 58
 Digestion 405
 amoebas 155
 annelid worms 152
 arachnids 155
 birds 164
 carnivorous plants 145
 crustaceans 154
 echinoderms 151
 enzymes 189
 gastropods 155
 insects 156
 lizards 162
 organs 196-7, 216
 starch 89
 X rays 100, 101
 Digital integrated
 circuits 350
 Digital multimeters 340
 Digital signals, computer
 networks 354, 355
 Digital thermometers 19
 Digitalis 254
Digitalis purpurea 254
Dilsea carnosa 158
 Dim filament lamp 50
 Dinoflagellates,
 classification 131
 Dinosaurs 269
 evolution of birds 128
 extinction 269
 Diodes 346-7
 integrated circuits 350
 semiconductors 336
Dionaea muscipula 145
 Dioxides, silicon 68
 Dip, folds 277
 Dip-slip faults 276
- Diplopoda 152
 Direct current (DC)
 338, 405
 capacitors 342
 diodes 346, 347
 inductors 344
 multimeters 339
 Disaccharides 114
 Disk brakes 25
 Discharging capacitors 342
 Disks, intervertebral
 182, 185
 Diseases 258-9, 381, 405
 autoimmune
 disorders 260
 germ theory 237
 immunization 261
 Disintegrating agents,
 tablets 254
 Displacement 405
 oscillation 30
 Displacement reactions
 94-5, 403
 Dissection, anatomical
 178
 Dissociation theory 67
 Dissolving 16
 Distal convoluted
 tubule 198
 Distal phalanx 228, 232
 Distance
 measurement 18
 speed 23
 theory of relativity 62, 65
 Distillation 403
 fractional 113
 solutions 70, 71
 Distilled water 84
 Distributaries, rivers 285
 Distribution curves
 368, 369
 Diverge 405
 light rays 52
 Division, computers 370
 Division, classification 405
 DNA (deoxyribonucleic
 acid) 121, 405
 bacteria 134
 bases 114
 cell nucleus 122
 cloning 265
 DNA fingerprinting
 121, 265
 genetic engineering 262
 human genome 265
 protein synthesis 124
 structure 115
 transcription 125
 viruses 134, 258
 Dobson Units 111
 Doctors
 diagnosis 238
 emergency care 244
 history 236
 Dodder 169
 Dodecahedrons 364
 Dog whelk 171
 Dogfish 159
- Dogs 166
 Doldrums 291
Dolichospula sylvestris
 157
 Dolphins 167
 flippers 129
 gestation period 380
 Domains, magnetism 40,
 41, 403
 Dome volcanoes 275
 Dominant alleles 126, 127
 Doping
 integrated circuit
 manufacture 351
 semiconductors 346
 Döppler blueshift 301, 308
 Döppler redshift 301, 308
 Dorado constellation
 388, 389
 Dorsal fins
 dolphins 167
 fish 158, 159
 Dorsal root, spinal
 cord 186
 Dorsal tarsometatarsal
 ligament 253
 Double bonds, organic
 chemistry 112
 Double decomposition
 80, 117, 405
 Double-planet systems
 321
 Double pulleys 27
 Double-star systems 325
 Dove constellation 388
 Down feathers 164
 Down quarks 60
 Downs process, sodium
 production 77
 Down's syndrome 265
 Downward meniscus 36
 Draco constellation 586
 Dragon constellation 586
 Dragonflies
 speed 380
 wings 156
 Drawing pins 21
 Dreschel bottles 110
 Drugs 254-5, 381
 discovery of 257
 emergency care 244
 fertility treatment 256
 genetic engineering 262
 infection and disease 258
 and transplant
 surgery 250
 Drumlins 285
 Drupelets 147
 Dry, four-elements
 theory 66
 Dry cells 96
 Dry ice 90
 Drying agents 95, 110
 Drying towers 107
 Dryland plants 145
Dryopteris filix-mas 139
 Dubhe 386, 387
 Duchenne muscular

- dystrophy 265
 Ductility, metals 76
 Ductless glands see Endocrine system
 Ductus deferens see Vas deferens
 Dugongs 167
 Dunes 279, 280
 Dung fungi, classification 131
 Duodenum
 birds 164
 human anatomy 217, 218
 Dura mater 186
 Dust, Moon 510
 Dust lanes, planetary rings 308
 Dwarf stars 525
 Dyes, tissue staining 237
 Dysentery 259
 Dysprosium 75
- E**
 E-mail (electronic mail)
 11, 354, 355
 Eagle constellation 386, 388
 Eagles 165
 homes 380
 Eardrum 203
 Ears 180, 203
 diagnosis 238
 ear drops 255
 implants 255
 mammals 166
 microsurgery 249
 Earth metals
 alkaline 100-1
 periodic table 74-5
 Earth sciences 7, 264-95
 age of Earth 267
 in ancient cosmology 9
 atmosphere 290-1, 306
 axial tilt 283
 biosphere 168
 celestial sphere 300
 centripetal force 28
 circumference 267
 coastlines 286-7
 Copernicus's theory 9
 cosmic rays 58
 crust 379
 data 382-3, 384
 diameter 296, 358
 earthquakes and volcanoes 274-5
 faults and folds 276-7
 formation of 268
 four-elements theory 66
 geological time 268-9
 geothermal power 47
 glaciers and ice sheets 282-3
 global warming 174
 global wind circulation 291
 gravity 18, 22, 23
 history of Earth sciences 266-7
 life zones 168
 magnetic field 41, 271
 Moon 310
 oceans 288-9
 orbit 270, 271, 304
 ozone layer 110, 111
 plate tectonics 272-3
 rivers 284-5
 rocks and minerals 278-9
 rocky landscapes 280-1
 seasonal change 271
 size 305
 structure 270
 temperature 32
 weather 292-5
 Earthquakes 274
 faults and folds 276
 historical theories 266
 measurement 385
 on the Moon 311
 plate tectonics 272
 Richter scale 267
 Earthworms 152
 classification 132
 and decomposition 173
 East China Sea 382
 Easterly winds 291
 Eccentric 403
 Eccentric orbits, planets 308
 Echidnas 167
 Echinodermata 135
 Echinoderms 150, 151
 classification 135
 Echinoidea 135
Echinus esculentus
 151, 171
 Echocardiography 240
 Echolocation 403
 bats 167
 Eclipses
 lunar 296, 310, 311, 385
 solar 306, 311, 385
 Eclipsing-binary stars
 324, 325
 Ecliptic plane 403
 celestial sphere 300
 Mercury's orbit 312
 Moon's orbit 311
 planetary orbits 304, 308
 solar eclipses 306
 Ecology 6, 168-75
 energy flow and food webs 170-1
 history 121
 human impact on environment 174-5
 natural cycles 172-3
 primary production 380
 Ecosystems 168, 403
 food chains 170
 human impact on environment 174
 ocean currents 288
 Ectoplasm, amoebas 135
 Ectothermic 403
 amphibians 160
 reptiles 162
 Eczema 581
 Edible crab 171
 Edible sea urchin 151
 Edison, Thomas Alva 395
 Edison effect 337
 light bulbs 336
 Edward's syndrome 263
 Efflorescent 92, 93, 403
 Effort 26
 levers 27
 EFM see Electronic fetal monitoring
 "Egg tooth," snakes 165
 Eggs (ovum) 198
 amphibians 160
 birds 164
 chromosomes 263
 earthworms 152
 fertility treatment 256
 fertilization 127, 199
 flowers 146
 frog spawn 161
 gastropods 153
 genetic cloning 265
 human 198
 insects 157
 lizards 162
 meiosis 127
 menstrual cycle 225
 monotremes 166
 reptiles 162
 snakes 163
 Egypt
 alchemy 66
 astronomy 297
 chemistry 67
 jet streams 291
 mathematics 358
 medicine 237
 Ehrlich, Paul 237, 395
 Eichhornia crassipes 145
 Einstein, Albert 11, 395
 theories of relativity 15, 297
 Einsteinium 75
 Einthoven, Willem 237, 395
 Ejaculation 198, 199
 Ejaculatory duct 223
 El Nath 386, 389
 Elasticity 403
 formula 378
 solids 34
 solids under tension 35
 Elbows 180
 artificial joints 253
 joint 183, 226
 El'brus 382
 Elder, European 144
 Electric charge 40, 403
 atoms 72, 96
 electromagnetic radiation 48
 ionic bonding 78
 mass spectrometry 116
 nuclear physics 58
 SI units 377
 Electric circuits 42-3
 formula 378
 resistance 42
 solder 105
 Electric current 96, 97,
 338, 403
 cathode-ray tubes 57
 circuits 42-3
 diodes 346-7
 electromagnetism 44
 electronic circuits 338
 formula 378
 inductors 344
 Ohm's Law 42
 potentiometers 341
 resistors 340
 SI units 377
 solar cells 47
 transistors 348, 349
 Van de Graaff generators 345
 Electric fields 403
 capacitors 342
 cathode-ray tubes 56, 57
 electrostatic forces 40
 radio waves 48
 Electric motors
 electromagnetism 44, 45
 energy transfer 17
 kinetic energy 17
 Electric resistance, SI units 377
 Electricity 40-1
 batteries 66
 car batteries 17
 chemical reactions 90
 conductors 76
 energy 15, 16
 history 336
 lightning 292
 loudspeakers 31
 nuclear physics 58
 oscilloscopes 31
 photovoltaic cells 17
 static 40
 superconductors 15
 Van de Graaff generators 41
 Electricity generation 46-7
 geothermal power 47, 446
 nuclear power stations 59
 renewable sources 46-7
 solar energy 47
 water power 46
 wind power 47
 Electrochemical cells
 96-7, 405
 Electrochemistry 67, 96-7
 Electrodes 403
 batteries 42
 cathode-ray tubes 336
 electrolytic cells 96
 electronic fetal monitoring 257
 voltaic cells 97
 Electrolysis 67, 96, 403
 Downs Process 77
 sodium hydroxide 98, 99
 Electrolytes 96, 403
 electroplating 97
 ions 67
 Electrolytic capacitors 343
 Electrolytic cells 96
 Electromagnetic force
 20, 404
 particle physics 60
 Electromagnetic
 radiation 48-9, 404
 black holes 330, 331
 discovery of 15
 Döppler shift 301
 light 52
 quantum physics 15
 quantum theory 62
 Sun 17
 Electromagnetic spectrum 48-9,
 299, 404
 telescopes 298
 visible light 50
 Electromagnetism
 44-5, 404
 compass needles 44
 discovery of 15
 electric motors 45
 electricity generation 46
 electromagnets 45
 freefall experiment 19
 history 15
 loudspeakers 31
 magnetic resonance imaging (MRI) 242
 particle accelerators 61
 particle physics 60
 solenoids 45
 Electromotive force (emf) 96, 404
 self inductance 344
 Electron guns 57
 Electron microscopes
 120, 121
 Electron shells 72, 404
 alkali metals 98
 covalent bonding 78
 discovery of 15
 halogens 110
 periodic table 74
 Electron microsopes
 120, 121
 Electron shells 72, 404
 alkali metals 98
 covalent bonding 78
 discovery of 15
 halogens 110
 periodic table 74
 Electronic circuits 338-9
 capacitors 342-3
 formula 391
 resistors 340
 symbols 390
 Electronic fetal monitoring (EFM) 257
 Electronic mail (e-mail)
 11, 354, 355
 Electronic thermometers 239
 Electronics 7, 335-55
 capacitors 342-3
 computers 352-3
 data 390-1
 diodes and semiconductors 346
 history 336-7
 inductors and transformers 344-5
 integrated circuits 350-1
 resistors 340-1
 silicon 104
 and society 10
 transistors 348-9
 Electrons 56-7, 404
 activity series 94
 alkali metals 98
 alkaline earth metals 100, 101
 atoms 72
 batteries 42
 capacitors 342
 cathode-ray tubes 57, 336
 current 96
 discovery of 15, 67
 doping a semiconductor 346
 electric circuits 42
 electric current 42
 electromagnetic radiation 48, 49
 excitation 56
 fluorescence 56
 halogens 110
 interference pattern 62
 ionic bonding 78
 isotopes 72
 light bulbs 43
 metals 76
 negative electric charge 40
 nuclear physics 58
 orbitals 56, 72
 oxidation 82, 83
 particle physics 60
 periodic table 74
 positron emission tomography (PET) 243
 probability theory 368
 quantum physics 15
 quantum theory 9, 62
 reduction 82
 sodium lamps 50
 solar cells 47
 in stars 330
 static electricity 40
 Van de Graaff generators 41
 X rays 49
 Electrophysiology 179
 Electroplating 97, 404
 Electroscopes 40, 404
 Electrostatic force 404
 attraction 78
 electric charges 40
 electric circuits 42
 Elements 68-9, 404
 alkali metals 98
 alkaline earth metals 100
 ancient medicine 236
 atomic number 72
 atoms 56
 boiling points 379
 compounds 68

- discovery of 67, 379
 Earth's crust 379
 flame tests 116
 halogens 110
 historical theories 66
 isotopes 72
 melting points 379
 metals 76-7
 minerals 278
 mixtures 70
 nitrogen 106
 nonmetals 76
 organic chemistry 112
 oxidation number 82
 oxygen 108
 periodic table 67, 74-5
 phosphorus 106
 protons 58
 Proust's Law 67
 spectral absorption
 lines 501
 in stars 300
 sulfur 108
 transition metals 102
 water and 92
- Elements, set theory 370
 Elephants 166
 energy requirements 580
 gestation period 380
 lifespan 380
 reproductive strategy 169
- Elhuyar, Fausto 379
 Elhuyar, Juan José 379
 Elixirs, drugs 255
 Ellesmere Island 382
 Ellipses 404
 cones 365
 planetary orbits 29
 Ellipsographs 359
 Elliptic geometry 365
 Elliptical galaxies
 328, 353
- Eltanin 387
 Elytrons 156
 Embalming 178
 Embryology 121
 Embryos (animals) 404
 birds 164
 human 199
 in-vitro fertilization 256
 reptiles 162, 163
- Embryos (plants) 404
 flowering plants 146
 seed fertilization 147
- Emergency medical
 care 244-5
- emf see
 Electromotive force
- Emission nebulae 326
 Emitters, transistors 548
 Empedocles 179, 395
 Empirical 404
 Empirical data,
 charts 369
 Empiricism 9
 Emu 165
 Enamel, teeth 197
 Endangered species 175
- Endocarditis 381
 Endocarp, succulent
 fruit 147
 Endocrine system
 179, 188-9
 Endocrinology 381
 Endodermis, roots 149
 Endometrium 199, 225
 Endoplasm, amoebas 135
 Endoplasmic reticulum
 122, 123
 Endoscopes 248
 Endoskeleton
 mammals 166
 tortoises 162
 Endosperm 147
 Endothelium 190
 Endothermic animals
 birds 164
 mammals 166
 Endothermic reactions
 90, 404
- Energy 16-17, 404
 activation energy 90
 acupuncture 256
 animal requirements 380
 Big Bang 332
 biochemistry 121
 catabolic reactions 124
 cathode-ray tubes 57
 cells 122
 conduction 32
 decomposition 69
 ecology 168
 electricity generation 46-7
 electromagnetic
 radiation 48
 electrons 56
 energy flow and food
 webs 170-1
 extracting metals from
 ores 76
 fireworks 101
 food webs 171
 heat 32-3, 90-1
 human impact on
 environment 174
 kinetic 16, 90
 Krebs cycle 121, 124
 latent heat 33
 melting points 78
 nuclear fission 58, 59
 nuclear fusion 58, 59
 nuclear power
 stations 59
 ocean waves 287
 oxygen cycle 175
 particle physics 60
 phosphorescence 57
 photosynthesis 100,
 123, 148
 Principle of the
 Conservation of
 Energy 17
 quantum theory 62
 respiration 124
 scientific history 15
 SI units 377
- Sun 17, 290, 306, 307
 theory of relativity 63
 transfers 17
 waves 30
 work 26
- Engineering,
 bioengineering 252-3
- ENIAC (Electronic
 Numerical Integrator
 and Calculator) 337
- Enif 387, 388
Enteromorpha linza 138
 Environment 404
 ecology 168-9
 energy flows and food
 webs 170-1
 human impact 174-5
 natural cycles 172-3
 natural selection 128
- Enzyme-linked
 immunosorbent assay
 (ELISA test) 261
- Enzymes 404
 arachnids 155
 biological washing
 powder 89
 carnivorous plants 145
 catalysts 88
 cell functions 124, 125
 crustaceans 154
 digestion of starch 89
 digestive system 189,
 196, 197, 219
 DNA fingerprinting 265
 fermentation 89
 genetic engineering 262
 genetic mutations 263
 Golgi body 122
- Epicenter, earthquakes 274
 Epicotyl 147
 Epidermal cells
 plants 123
 skin 181
- Epidermis
 plant anatomy 149
 skin 181
- Epididymis 199, 222
 Epiglottis 204, 205, 215
 swallowing 194, 196
- Epimysium 184
 Epineurium 187
- Epiphysis
 bone 182
 phalanx 229
- Epiphytic orchids 145
 Epiploic vessels 216
 Epithelial cells 122
- Equalization of
 temperature 33
- Equations
 algebra 362
 fractals 372
 logic 371
- Equator 270, 404
 celestial 300
 global wind
 circulation 291
- Equilateral triangles 392
- fractals 372
- Equilibrium 20, 404
 chemical reactions
 80, 81
 oscillation 30
- Equinoxes 271, 300
Equisetum arvense 139
- Equuleus constellation
 387, 388
- Equus 129
- Eras, geological 267
- Eratosthenes 267, 296,
 297, 395
- Erbium 75
- Erectile 404
- Eridanus constellation
 387, 388
- Erosion 404
 coastlines 286
 glacial 285
 rivers 284
 rock cycle 278
 rocky landscapes 280-1
- Error bar 404
- Erythrocytes 191
- Escape velocity, black
 holes 330
- Eskers 283
- Esophagus
 annelid worms 152
 arachnids 155
 birds 164
 hiatus 220
 human anatomy 200,
 204, 212, 215, 218
 insects 156
 lizards 162
 mammals 166
 peristalsis 197
 swallowing 196
- Estrogen 189
- Estuaries 284, 286
- Ethane 112, 113
- Ethanoic acid 379
- Ethanol 379
 fermentation 156
- Ether 237
- Ethmoid bone 183, 206
- Ethyne 112, 113
- Eubacteria 151
- Euclid 359, 364, 395
 Elements 358, 359
- Euglenoid flagellates 135
 classification 131
- Euglenophyta 131
- Eukaryotes 122, 404
 fungi 136
 protists 134
- Eurasian plate 272
- Europa 316
- Europe
 data 382
 formation of 273
 glass 253
 human 181
 octopuses 153
 optic nerve 207
 research 179
 seeing by reflected
- Evaporation 404
 states of matter 16, 32
- Evening Star 312
- Event horizon, black
 holes 330, 331
- Everest, Mount 382, 383
- Evolution 128-9, 404
 discovery of 120-1
 fossils and 266
 microorganisms 258
 phylogeny 132
- Excited 56, 404
- Exhalation 194, 195
- Exine, pollen grains 146
- Exocarp, succulent
 fruit 147
- Exoskeleton, arthropods
 154, 156
- Exosphere 290
- Exothermic reactions 404
 burning 77, 83, 90
 formation of sodium
 chloride 76
 preparation of ethyne 112
- Expansion
 solids 35
 thermal 34
- Expansion joints 34
- Experiments 9, 14, 18-19
- Explosives 106
- Extensors 404
 arthropods 154
- External auditory
 meatus (canal) 205,
 204, 206
- Extinction 128, 404
 human impact on
 environment 174, 175
 mass 269
- Extraction, metals 76, 77
- Extraterrestrial life,
 space probes 302
- "Eye," hurricanes 293
- Eye spot, euglenoids 135
- Eyeball 203, 204
- Eyes
 anatomy 203
 arachnids 155
 artificial lenses 252, 253
 birds 165
 cataracts 237, 252
 color blindness 263
 color vision 50
 compound 156
 corneal transplants 251
 crocodilians 163
 crustaceans 154
 diagnosis 258
 eye drops 255
 fish 158, 159
 gastropods 153
 genetic mutations 265
 glass 253
 human 181
 octopuses 153
 optic nerve 207
 research 179
 seeing by reflected
- light 52
 spiders 155
 virtual-reality
 surgery 249
 vision 205
 vision tests 239
- Eyots 285
- Eyre, Lake 382
- ## F
- F see Farads
- F-block, periodic table 102
- Fabircius, Hieronymus
 179, 395
- Fabrics, bleaching 111
- Fabry, Charles 267, 395
- Face 181
 bones 200, 206
 muscles 200, 405
- Facial nerve 202
- Fahrenheit scale 32,
 376, 405
- Fairy shrimps,
 classification 135
- Falcato tinunculus* 165
- Falciform ligament 196,
 216, 217, 219
- Falcons 164, 165
- Falling 19
- Fallopian tubes 198, 224
 fertilization of ovum 199
 menstrual cycle 225
- False vocal cords 194
- Family, classification 130
- Fan worms 152
- Fangs, snakes 163
- Faraday, Michael 15, 395
- Farads (F) 342
- Farey, John 359
- Fascia, transplants 251
- Fascicle 187
- Fast-acting drugs 405
- Fats
 adipose tissue 181
 digestion 196, 216, 217
 production of soap 99
- Fatty acids 98, 99
- Fault plane 276
- Faults, plate tectonics 276
- Fava beans 147
- Fax machines 337, 354
- Feather stars,
 classification 133
- Feathers 164
 flight 165
 fossil 128
- Feces 196, 197, 222, 225
- Feet
 amphibians 160
 birds 164, 165
 bones 232
 crocodilians 163
 duck-billed platypus 167
 gastropods 153
 human anatomy 180
 mammals 166
 muscles 232-3

- tendons 255
toenails 181
Feet, unit of
 measurement 376, 377
Felidae 150
Femoral cutaneous
 nerve 221, 231
Femoral nerve 186,
 221, 250
Femur
 birds 164
 dynamic hip screws 253
 human anatomy 182
 joints 185
 mammals 166
 spiders 155
Fennec fox, energy
 requirements 380
Fermat, Pierre de 359
Fermentation
 enzymes 88, 89
 yeasts 136
Fermi, Enrico 15, 395
Fermium 75
Ferns 158, 159
 classification 131
 fractals 372
Ferrite, inductors 344
Fertility treatments 256
Fertilization 127, 405
 amphibians 160
 conifers 141
 flowering plants 144, 146
 gymnosperms 140
 human body 199, 225
 seeds 147
Fertilizers
 nitrogen 106
 pollution 174
Fetus
 blood sampling 256
 ultrasound scanning 240
FEV meters see
 Forced Expiratory
 Volume meters
Feynman diagram 60
Fiber-optic cables 357
 computer networks 354
 endoscopes 248
 laser surgery 249
Fibroblasts 405
 vascular grafts 252
Fibula
 human anatomy 182,
 185, 250, 255
 joint 185
 mammals 166
Field-effect transistors
 (FET) 348
 integrated circuits
 350, 351
Field laboratories 10
Field of vision 53
Filaments (life
 sciences) 405
 flowers 143, 144
 succulent fruit 147
Filaments (physics) 405
 cathode-ray tubes 57
 light bulbs 43, 50
 Sun 307
Film, thin film
 interference 55
Films, photographic 109
Filter paper 70, 71
Filters
 color 51
 polarizing 54, 55
Filtration 405
 mixtures 70
 muddy water 71
Fimbriae 199, 224
Finches, evolution 128
Fingers 180
 bones 228
 muscles 185, 229
 myoelectric arms 255
 nails 181
Fins
 dolphins 167
 fish 158, 159
Fire, four-elements
 theory 66
Fire bricks 77
Firewalls, computer
 networks 355
Fireworks 100, 101
Firm 282
First aid 405
 ambulances 244
Fish 158-9
 acid rain 174
 classification 133
 endangered species 175
 evolution 269
 food webs 171
 species interactions 169
 tagging 175
Fish-skin disease 265
Fishes constellation 386
Fission (life sciences) 405
Fission, nuclear physics
 15, 58, 59, 405
Fissure volcanoes 275
Fissures, lungs 194
Fixed resistors 340
Fixer, sodium
 thiosulfate 109
Flagella
 bacteria 134
 euglenoids 155
Flagellates 134
 classification 131
Flame tests 116
Fleming 164
Flares, Sun 307
Flat shapes, geometry 364
Flatworms 152
 classification 132
Fleas 157
Fleming, Alexander
 257, 395
Fleming, John Ambrose
 336, 337, 395
Flexors 405
Flexorps 154
Flies
 and decomposition 175
 lifespan 380
Flight
 bats 167
 birds 164, 165
Flight feathers 164
Flightless birds 165
Flippers
 evolution 129
 seals 166
Floating 36, 37
Floodplains 285
Florets, flowers 144
Flotation principle 15
Flowering plants 142-7
 classification 131
 reproduction 146-7
Flowers 142
 pollination 144
 structure 143
 types 144
 wind-pollinated
 plants 146
Fluid ounces 376
Fluidram 376
Fluids 405
 lubrication 24, 25
Flukes 152
 classification 132
Fluorescence 56, 405
 nebulae 327
Fluorescent lamps 50
Fluoride, ions 110
Fluorine
 atomic number 58
 CFCs 111
 covalent bonding 79
 ionic bonding 78
 periodic table 75, 110
Fluorite 279
Fluted bird's nest fungi 136
Flying Fish
 constellation 388
Flying mammals 167
Focal length 405
 concave mirrors 53
 convex lenses 53
 telescopes 298
Focusing an image 53
Folds, plate
 tectonics 276-7
Foliose lichen 137
Folk medicine 256
Follicles, hair 181
Fomalhaut 387, 388
Food chains 170
 food webs 171
Food webs 168, 170,
 171, 405
Fool's gold 68
Foot see Feet
Foramen magnum 206
Foramina, perineal 222
Force 20-3, 405
 adhesive 36
 atomic 72
 centripetal 28-9
cohesive 36
 compression 34
 electric fields 40
 electromagnetism 10
 electrostatic 40
 equilibrium 20
 formula 378
 friction 24-5
 gravity 20, 25
 magnetism 41
 Newton's Laws 14, 22-3
 oscillation 30
 particle physics 60-1
 pressure 21
 reaction 20
 resultant 20
 SI units 377
 simple machines 26
 tension 34, 35
 turning 21
 upthrust 37
 work 26
Force lines 44
Forced Expiratory
 Volume (FEV)
 meters 261
Forceps
 artery 246
 biopsy 248
 childbirth 256, 257
Forearm 180
 joint 185
 muscles 185, 228-9
Forecasts, weather 292
Foregut
 arachnids 155
 insects 156
Forehead 181
Forensic medicine, DNA
 fingerprinting 265
Forests, life zones 168
Forewings, insects 156
Fork lightning 292
Formulas
 algebra 362, 365
 chemical 379
 circuits 391
 physics 378
Fornax constellation
 387, 388
Fornix 187, 207
Fossa navicularis 225
Fossil fuels 405
 acid rain 174
 global warming 174
Fossils 266, 405
 and evolution 128-9
 evolution of
 the Earth 268
 formation 269
 geological eras 267
 palaontology 120
 plate tectonics 267
Foundations 21
Fountain experiment,
 ammonia 93
Four-elements theory 66
Fovea 205
cells 122
 classification 130, 131
 decomposition 173
 infections 258, 259
 microorganisms 134
 symbiosis 137
Fungiform papilla 205
Fur, mammals 166
Furnace constellation 388
Furnaces
 fractional distillation 113
 manufacture of steel 105
Furud 589
Fusion, nuclear physics
 58, 59, 326, 405

G

- Gacrux 389
Gadolinium 75
Gadus morhua 158
Gagarin crater, Moon 311
Galapagos Islands 128
Galathea Deep 382
Galaxies 328-9
 Big Bang 332-3
 black holes 330
 centers 299
 data 384
 Döppler shift 301
 history of astronomy 297
 Hubble's Law 333
 images of 299
 radio telescopes 299
Galen 178, 179, 237, 395
Galena 68
Galeras 385
Galilean moons, Jupiter
 316
Galileo Galilei 15, 395
 clocks 14
 Galilean moons 316
 telescopes 297
Galileo space probe 302,
 303, 316
Gall bladder
 bile 196
 human anatomy 216,
 217, 219
 mammals 166
Galle, Johann Gottfried
 297, 395
Gallium 75
Gallons 376, 377
Galvani, Luigi 179, 395
Gametes 405
 conifers 141
 fertilization 147
 meiosis 127
 nonflowering plants 138
 pollination 146
Gametophyte
 generation 138
Gamma rays 405
 astronomy 299
 discovery of 15
 electromagnetic
 spectrum 48, 49, 299

- positron emission tomography (PET) 245
radioactivity 58
Sun 307
- Gamma Velorum 386, 389
- Ganymede 316
- Gas chromatography 70
- Gas exchange, alveoli 195
- Gas giants 304, 405
Neptune and Pluto 320-1
rings 308, 309
Saturn and Uranus 318-19
- Gas laws, formulas 378
- Gas loops, Sun 307
- Gas mantles 78
- Gases 38-9, 405
air 70, 106
atmosphere 290-1
Boyle's Law 58
Charles' Law 59
chlorine 76, 110
diffusion 58
evaporation 16
as liquids 90
mixtures 70
molar volume 75
natural gas 32, 269
nitrogen 106
nonmetals 76
oxygen 108
particles 32
periodic table 74
pressure 38-9
Pressure Law 39
temperature 32, 38-9
water and 92
- Gasherbrum 385
- Gasoline
car engines 17
fractional distillation 115
- Gastroenterology 381
- Gastropneumatic fold 219
- Gastropoda 132, 152
- Gastropods 155
- Gastrotricha 135
- Gastrovascular cavity, anemones 150
- Gauge bosons 60, 405
- Gaussian distribution
curves 368, 369
- Gavarnie 385
- Gears
electric motors 17
wind turbines 47
- Geckos 165
- Geiger-Muller tubes 58, 405
- Gell-Mann, Murray 15, 395
- Gemini constellation 323, 386, 389
- Geminids meteor shower 323
- Gemmae, liverworts 138
- Genera see Genus
- General anaesthetics 247
- General practitioners 238
- Generating angle, cones 365
- Generators 405
alternating current 358
electricity generation 46-7
hydroelectricity 46
nuclear power stations 59
Van de Graaff 41, 343
wind power 47
- Genes and genetics 262-3, 405
analysis 265
cloning 265
gene therapy 257
heredity 126, 127
history 121
human genome project 10, 121
mitosis 126
mutations 265
pollination 146
prenatal screening 256
protein synthesis 124
viruses 134
- Genetic code 405
DNA 114, 115
genetic engineering 262
- Genetic disorders 262, 406
- Genetic engineering 262
- Genetic variation 406
- Genitofemoral nerve 220, 221
- Genome 406
human genome project 10, 121, 262, 265
viruses 258
- Genotypes 406
asexual reproduction 126
Genus, classification 130
- Geocentric model, universe 314
- Geological column 268
- Geological eras 267
- Geological time 268-9
- Geology 266
coastlines 286-7
earthquakes and volcanoes 274-5
Earth's structure 270
faults and folds 276-7
glaciers and ice sheets 282-3
plate tectonics 272-3
rivers 284-5
rocks and minerals 278-9
- Geometry 364-5
coordinate 358-9, 364, 366-7
data 392-3
fractals 359, 372
history 358, 359
non-Euclidean 358, 359, 364
- Geothermal power 46, 47
- Geriatrics 381
- Germ theory 257
- Germanium 75, 104
- Germany, mathematics 358
- Germinal center, lymph nodes 195
- Germination
conifers 141
seeds 147
- Germis 406
- immune system 260
infection and disease 258-9
- Gestation periods 380
- Geysers 275
- Gharia 162
- Ghost anemone 150
- Gilbert, William 15, 395
- Gill, unit of
measurement 376
- Gill slits, fish 159
- Gills 406
axolotls 161
crustaceans 154
fish 158, 159
fungi 136
gilled mushrooms 137
tadpoles 161
- Ginkgo 140
classification 131
Ginkgo biloba 140
- Ginkgophyta 131, 140
- Giotto space probe 297
- Giraffes 120
- energy requirements 380
- Gizzard
annelid worms 152
birds 164
Glabella 206
- Glaciers 282-3
erosion 278
hydrological science 266
sizes 385
- Glands 406
adrenal 188, 189, 220
bulbourethral 199, 222
endocrine system 188-9
lacrimal 200
mammary 208
ovaries 188, 189, 198, 199
pancreas 188, 189
parathyroid 188, 189
parotid 196, 200, 201, 205
pineal 187, 188, 189
pituitary 187, 188, 189, 207
prostate 198, 199, 225
salivary 189, 196, 201, 205
sebaceous 181
testes 188, 189, 198, 199
thymus 192
thyroid 188, 189, 204, 205, 214
- Glans
clitoris 225
penis 225
- Glass 105
capillary action 36
discovery of 67
flow 32
prisms 49
quartz 104, 105
refraction 52
- total internal reflection 52
- Glasses, vision tests 259
- Glaucoma 381
- Glenoid cavity 227
- Glisson, Francis 179, 395
- Global warming 174
- Globular clusters, stars 324
- Glucagon 189
- Glucose
fermentation 89, 136
glycolysis 124
liver and 179
organic chemistry 114
photosynthesis 148
positron emission tomography (PET) 245
- Glucos 60, 406
- Gluteal fascia 222, 225, 231
- Gluteal fold 180
- Glycerol, fatty acids 99
- Glycogen
in cells 122
liver and 179
- Glycolysis, respiration 124
- Gneiss 279
- Gnetophyta 131
- Gnetophytes 140
classification 131
- Goats, gestation period 380
- Gobi Desert 385
- Gödel, Kurt 359, 395
- Gold
alchemy 66
atoms 78
discovery of 379
element 68
melting and boiling points 379
periodic table 75
reactivity 94
transition metals 102
- Gold algae, classification 131
- Gold leaf
electroscopes 40
- Golden ratio 361
- Golden rectangle 361
- Golgi, Camillo 179, 395
- Golgi body
animal cells 122
euglenoids 135
plant cells 125
- Gonads
anemones 150
echinoderms 151
- Gondwana 269, 275
- Goniometers 266
- Gonopores
echinoderms 151
gastropods 153
- Gorges 281
- Gorilla gorilla* 167
- Gorillas 167
energy requirements 380
- Graben, rift valleys 276
- Grades, classification 133
- Graffias 389
- Grafts, surgery 250, 251, 252
- Grain, unit of
measurement 376
- Grams 376, 377
- Grana, chloroplasts 148
- Grand Canyon 314
- Grand unified theory (GUT) 15
- Granite
formation 279
inselbergs 280
tors 281
- Grants, scientific
funding 11
- Granulating agents, tablets 254
- Graphite 68
atoms 78, 104
- Graphs 18, 406
algebra 362
chaos theory 372
freefall experiment 19
statistics 368, 369
- Grasses 170
- Grasshoppers, metamorphosis 156
- Grasslands
geological time 269
life zones 168
- Graunt, John 359
- Gravity 406
asteroid belt 323
Big Crunch 332, 333
centripetal force 28
force 20
formula 378
freefall experiment 19
galaxies 528
globular clusters 324
gyroscopes 29
neutron stars and black holes 350, 351
Newton's theory of 14
oscillation 30
particle physics 60
planetary rings 309
planets 29, 308
solar system 22, 23, 304
stars 326, 327
theory of relativity 62, 63
tidal power 47
turning force 21
universe 333
weight 18
wormholes 331
- Gray matter 186, 187, 207
- Gray mullet, thick lipped 171
- Great alar cartilage, nose 205
- Great Bear constellation 386, 387
- Great Bear Lake 385
- Great Britain, size 382
- Great Dog constellation 388, 389
- Great Red Spot, Jupiter 316, 317
- Great Rift Valley 273, 276
- Greater auricular nerve 202
- Greater omentum 216, 217, 219
- Greece, ancient 8, 9
anatomical research 178
astronomy 296
life sciences 120
mathematics 358
medicine 236
physics 14
theories of matter 66
- Green algae 135
classification 130
symbiosis 137
- Green light
additive process 51
color vision 50
destructive interference 55
LEDs (light-emitting diodes) 50
subtractive process 51
white light spectrum 49
- Green seaweeds 138
- Greenhouse effect 174, 290, 406
on Venus 313
- Greenland
ice sheet 282, 285
size 382
- Grew, Nehemiah 121, 395
- Groundwater 406
limestone caves 281
rivers 284
water table 284
weathering 280
- Growth hormone 188, 262
- Grus constellation 387, 388
- Guaira Falls 385
- Gualltiri 385
- Guanine 115
- Guinea pigs, lifespan 380
- Gums 196, 197
- Gunpowder
discovery of 67
fireworks 101
- Gutenberg, Beno 267, 395
- Guyots 288
- Gynecology 381
- Gynoeceum, flowers 143
- Gypsum 279
- Gyroscopes 406
angular momentum 29
centripetal force 28
- Gyrus 187, 206

H

Haber, Fritz 107

Haber process, ammonia production 106, 107

Habitats 406
amphibians 160
ecology 168
flowering plants 144

- human impact on environment 174
 lladar 389
 llade, faults 276
 lladley, George 267, 395
 lladrons 60, 406
 particle accelerators 61
 Haeckel, Ernst Heinrich Philipp August 121, 395
 Hafnium 74
 Hagfish 159
 classification 133
 Hahn, Otto 15, 395
 Hail 292
 Hair, mammals 166
 Hair follicles 181
 Halide ions 110, 117
 Halley, Edmond 297, 395
 Halley's comet 297
 Hallux 232
 Halogens 110-11
 chemical analysis 117
 Hamal 387, 388
 Hammer thrower 28
 Hamsters, gestation period 380
 Hands 180
 artificial 253
 bones 228, 229
 joints 183
 mammals 166
 muscles 228-9
 myoelectric arms 253
 Hanging valleys 282, 283
 Haploid cells, meiosis 127
 Harbey, William 179
 Hard disks, computers 353
 Hard palate 196, 205
 Hard water 86, 100
 Hardness
 minerals 278
 Mohs' scale 279
 Hare constellation 388
 Hares, speed 380
 Harriers (birds) 165
 Harvard Observatory 297
 Harvestmen 154, 155
 classification 133
 Harvey, William 236, 237, 395
 Hatching, snake eggs 163
 Haustoria 169
 Haustrium 197, 217, 218, 219
 Havers, Clopton 179
 Haworthia truncata 145
 Hay fever 381
 hCG see Human chorionic gonadotrophin
 Head, human 176, 180, 200-7
 anterior view 205
 blood vessels 202
 bones 206
 brain 207
 ears 203
 eyes 203, 205
 facial muscles 200
 lateral view 204
 magnetic resonance imaging 234-5
 muscles 200-3
 nerves 202
 nose 203, 205
 skull 206
 Headlamps 17
 Headlands 286
 Heart
 amphibians 160
 birds 164
 cardiac muscle 184
 crustaceans 154
 echocardiography 240
 fish 158
 gastropods 153
 human anatomy 182, 190-1, 214
 insects 156
 lizards 162
 mammals 166
 measuring blood pressure 239
 monitoring heart rate 244
 open-heart surgery 246, 247
 pacemakers 252, 253
 posterior view 213
 research 179
 transplants 237, 246, 251
 Heart-lung machines 246, 247
 Heart urchins, classification 133
 Heart valves
 mechanical 252, 253
 transplants 251
 Heartbeat 238
 Heat 90-1
 cars 17
 conductivity 32
 conductors 76
 decomposition 69
 electromagnetic radiation 49
 endothermic reactions 90
 energy 15, 16, 32-3
 equalization of temperature 33
 exothermic reactions 90
 extraction of metals 77
 fireworks 101
 four-elements theory 66
 global warming 174
 greenhouse effect 174, 290
 heating 33
 historical theories 14-15
 latent 32
 nuclear power stations 59
 radiation 32
 receptors 181
 thermite reaction 91
 see also Temperature
 Heaviside, Oliver 267, 395
 Hectares 376, 377
 Hectoliters 376
 Heels 180
 Heka 324, 386
 Heliostats 306
 Helium
 atmosphere 290
 Big Bang 332
 discovery of 379
 gas chromatography 70
 on Jupiter 316, 317
 melting and boiling points 379
 on Neptune 320
 nuclear fusion 59
 particle accelerators 61
 periodic table 75
 on Saturn 318
 spectral absorption lines 301
 in stars 326
 Sun 306, 307
 on Uranus 318, 319
 Helix, geometry 392
 Hemichordata 133
 Hemal spines, fish 158
 Hematology 381
 Hemocoel, insects 156
 Hemodialysis 251
 Hemoglobin 114, 115, 191
 Hemophilia 263
 Hemispheres
 cerebral 187, 206, 207
 geometry 365, 392
 Henle, Friedrich Gustav Jakob 237, 395
 Henle, loop of 198
 Henry, Joseph 337, 395
 Heparin 261
 Hepatic duct 216
 Hepatic flexure 218
 Hepatic portal system 219
 Hepatitis 261, 381
 Hepatoduodenal ligament 217
 Hepatogastric ligament 217
 Hepatophyta 130, 138
 Herbaceous flowering plants 142
 Herbaceous shoots 149
 Herbal remedies 236
 Herbivores 406
 energy flow 170
 lizards 163
 teeth 166
 Hercules constellation 386, 388
 Herdsman constellation 386
 Heredity 121, 126-7
 Hermaphrodites
 earthworms 152
 gastropods 153
 Hernias 251
 Herons 165
 Herring gull 171
 Herschel, William 15, 297, 395
 Hertz 31, 377
 Hertz, Heinrich Rudolf 15, 395
 Hertzprung-Russell diagram, stars 324, 325
 Hess, Harry Hammond 267, 395
 Heterotrophs 406
 fungi 136
 and photosynthesis 148
 protists 134
 Hexagonal system, crystals 33
 Hexagons, geometry 392
 Hexane 114
 Hexanedioic acid 114
 Hiatus
 aortic 221
 esophagus 220
 Hierarchy of complexity, ecology 168
 Higgs bosons 60, 406
 High frequency sound waves, ultrasound scanning 240
 High pressure compression 31
 weather 292
 Hilum 147
 Hilus 193
 Himalayas 276, 277
 Hindgut
 arachnids 155
 insects 156
 Hindu medicine 236, 237
 Hindwings, insects 156
 Hinge joints 183
 Hinge line, folds 277
 Hipparchus 296, 395
 Hippocrates 237, 395
 Hippocratic Method 236
 Hippopotamuses, lifespan 380
 Hips 181, 182, 183
 artificial joints 253
 dynamic hip screws 253
 hip girdle 222
 joint 183
 muscles 221
 Hirudinea 132
 Histamine 261
 Histograms 372
 Histology 179
 History of science 8-9
 astronomy and astrophysics 296-7
 chemistry 66-7
 earth sciences 266-7
 electronics and computer science 336-7
 human anatomy 178-9
 mathematics 358-9
 medical science 236-7
 physics 14-15
 HIV see Human Immunodeficiency Virus (HIV)
 Hog's-back, rocky landscapes 280
 Holdfast, seaweeds 138
 Hole (electronics) 406
 Hölloch 383
 Holmium 75
 Holothuroidea 133
 Homarus gammarus 171
 Homeostasis, human body 179
Homo sapiens 269
 Homologous chromosomes 127
 Honey guide, flowers 143
 Honshu 382
 Hooke, Robert 120, 395
 Hooves, horses 129, 166
 Horizontal fissure, lungs 194
 Hormones 188-9, 406
 genetic engineering 262
 research 179
 topical drugs 255
 Horn peaks 285
 Hornworts, classification 131
 Horsehair worms, classification 133
 Horsehead Nebula 326
 Horses 166
 evolution 129
 speed 380
 Horseshoe crabs, classification 133
 Horsetails 138, 139
 classification 131
 Horst, faults 276
 Hospitals
 emergency care 244-5
 history 236
 surgery 246-7
 Hosts 406
 viruses 134
 Hot, four-elements theory 66
 Hot-air balloons 39
 Hot objects 49
 Hot springs 275
 Hourglass Nebula 327
 House mice
 energy requirements 380
 gestation period 380
 lifespan 380
 Houseflies, lifespan 380
HST see *Hubble Space Telescope*
 Hubble, Edwin Powell 297, 328, 396
Hubble Space Telescope (HST) 10, 297, 298
 Hubble's Law 332, 333
 Hudson Bay 382
 Human body 6, 176-235
 abdomen 216-21
 brain, spinal cord and nerves 186-7
 digestive organs 196-7
 endocrine system 188-9
 energy requirements 380
 forearm and hand 228-9
 gestation period 380
 head and neck 200-7
 heart and blood vessels 190-1
 history 178-9
 human genome project 10, 121, 262, 263
 immune system 260-1
 lifespan 380
 lower leg and foot 232-3
 lymphatic system 192-3
 muscles 184-5
 pelvic region 222-5
 pregnancy and childbirth 256-7
 reproductive system 198-9
 respiratory organs 194-5
 shoulder and upper arm 226-7
 skeleton 182-3
 skin, hair and nails 181
 speed 380
 thigh 230-1
 thorax 212-15
 trunk 208-11
 urinary system 198
 Human chorionic gonadotrophin (hCG) 256, 406
 Human
 Immunodeficiency Virus (HIV) 258
 ELISA test 261
 Human impact, environment 174-5
 Humerus
 birds 164
 human anatomy 182, 226, 227
 joint 183
 mammals 166
 Humors, ancient medicine 236
 Hundred 377
 Hundredweights 376
 Hunter, John 237, 396
 Hunter constellation 386
 Huron, Lake 383
 Hurricanes 292, 293
 Hutton, James 267, 396
 Hyaline cartilage 215
 Hybrid orbitals 79, 104, 105
 Hybridization 120, 406
 Hydra constellation 386, 388
 Hydras 150
 classification 132
 reproduction 126
 Hydrated cobalt chloride 75
 Hydrated crystals 92
 Hydrated iron oxide 379
 Hydrocarbons 406
 bonds 112
 catalytic converters 89
 combustion 83
 cracking 112, 113

- fractional distillation 115
 organic chemistry 112
 Hydrochloric acid
 chemical reactions 81
 pH scale 84
 preparation of 85
 preparation of
 chlorine 110
 preparation of
 hydrogen sulphide 109
 Hydroelectric power 46
 Hydrogen
 acid salts 86, 87
 acids 84
 ammonia 68, 106, 107
 atmosphere 290
 Big Bang 332
 bonding 78, 79, 406
 and combustion 83
 cosmic rays 58
 covalent bonding 79
 dehydrating agents 92
 discovery of 67, 379
 DNA 115
 in Earth's crust 379
 electrolytic
 decomposition of
 water 96
 ethanol 68
 fatty acids 99
 formula 379
 hydrocarbons 112
 on Jupiter 316, 317
 magnetic resonance
 imaging (MRI) 242
 on Neptune 320
 nuclear fusion 59
 periodic table 74
 pH scale 84
 photosynthesis 148
 reaction of sodium with
 water 98
 reactivity of metals 95
 on Saturn 318
 spectral absorption
 lines 301
 in stars 326, 327
 Sun 306, 307
 on Uranus 318, 319
 voltaic cells 97
 water 68, 92
 Hydrogen chloride 84, 85
 Hydrogen fluoride 79
 Hydrogen oxide,
 formula 379
 Hydrogen peroxide 108
 Hydrogen sulfide 108
 on Neptune 320
 preparation of 109
 Hydrogencarbonates
 acid on 85
 formula 379
 testing for 116
 Hydrographs, storm 284
 Hydroids, classification 132
 Hydrological science 266
 Hydronium
 formula 379
 ions 84, 95, 406
 Hydrostatic skeletons 406
 sea anemones 150
 Hydroxide
 anions 98
 bases 84
 ions 84
 salts 86
 Hydrozoa 132
 Hydrus constellation 388
 Hygiene, operating
 rooms 246
 Hygroscopic 406
 compounds 92, 93
 Hymenium, fungi 136
 Hyoid bone 194, 201,
 204, 205
 Hyperbolas, cones 365
 Hyperbolic geometry 365
 Hyperphae
 fungi 156
 lichens 137
 mushrooms 137
 Hypo 109
 Hypocenters,
 earthquakes 274
 Hypogeal germination 147
 Hypogymnia physodes 137
 Hypopharyngeal gland,
 insects 156
 Hypotenuse 366-7
 Hypothalamic
 hypophyseal tract 188
 Hypothalamus 187,
 207, 406
 endocrine system
 188, 189
 Hypotheses 9
 Hyracotherium 129
- I**
 Iatrochemistry 66,
 120, 237
 Iatrophysics 237
 Ibises 165
 Ice
 caves 282
 clouds 292
 comets 322
 erosion 280
 glaciers 282
 on Mars 315
 on Neptune 320
 planetary rings 308, 309
 on Pluto 321
 rock cycle 278
 Ice ages 267
 coastlines 286
 polar ice sheets 283
 Ice sheets 282-3
 continental shelf 288
 Icebergs 282
 Icefalls 282
 Iceland
 plate tectonics 273
 volcanoes 275
 Icosahedrons 364
 Ichthyosis 263
 Ichtyostega 268
 Ideal-Gas Equation 378
 Igneous rocks 407
 formation 278-9
 historical theories 266-7
 Moon 310
 Iguanas 163
 Ileocecal junction 219
 Ileocecal valve 197, 219
 Ileum 196, 197, 216, 217,
 218, 219
 Iliac crest 183, 208, 209,
 210, 221, 230, 231
 bone marrow 250
 Iliac lymph nodes 192
 Iliac spine 217
 Iliohypogastric nerve 221
 Ilioinguinal nerve 221
 Iliotibial tract 230, 231
 Ilium 182, 183, 223, 224
 Images 407
 convex lenses 53
 formula 378
 Imaging, medical 240-3
 Immersed objects 37
 Immune system 260-1
 Acquired Immune
 Deficiency Syndrome
 (AIDS) 258
 and artificial body
 parts 253
 lymphocytes 250
 research 179
 transplant and graft
 rejection 250
 Immunization 261
 allergies 260
 Immunological
 reactions 407
 transplants 250
 Immunosuppressant
 drugs 254
 Impedance, inductors 344
 Imperial units 376-7
 "Impetus" theory 14
 Implants
 artificial body
 parts 252-3
 drugs 255
 In parallel 407
 In series 407
 In vitro fertilization
 (IVF) 256
 Incandescence, Sun 307
 Inches 376, 377
 Incisions, surgery 248, 407
 Incisor teeth
 carnivores 166
 herbivores 166
 human anatomy 196, 204
 Inclined plane 26
 Incomplete
 metamorphosis 156
 Incompleteness
 theorems 359
 Incubation, eggs 164, 407
 Incubators, babies 256, 257
 Incus 203
 Index finger 228, 229
 Index fossils 269
 India
 astronomy 296, 297
 continental formation 275
 mathematics 358
 medicine 236
 Indian Ocean, size 382
 Indicators, pH scale 84, 407
 Indium 75
 Indo-Australian plate
 272, 277
 Induction 407
 charged atoms 40
 Inductors 338, 344-5
 Indus constellation 388
 Inert 74, 407
 Inertia 22, 407
 Infection 258-9, 407
 antiseptics 237
 body temperature 239
 diagnosis 238
 transplant surgery 250
 Inferior tarsus
 ligament 200
 Infinity 360
 Inflammation, mast
 cells 261
 Inflorescences,
 flowers 144
 Influenza vaccine 261
 Information, computer
 networks 354-5
 Infraorbital foramen 206
 Infrared Astronomical
 Telescope (IRAS) 299
 Infrared radiation 407
 astronomy 299
 computer networks 354
 discovery of 15
 electromagnetic
 spectrum 48, 299
 hot objects 49
 Hubble Space
 Telescope 298
 light-emitting diodes
 (LEDs) 347
 Sun 307
 transfer of heat 33
 Infratrochlear nerve 202
 Infundibulum 188
 Ingen-Housz, Jan 121, 396
 Inguinal ligament
 217, 230
 Inguinal lymph nodes 192
 Inhalers, drugs 255
 Injections
 drugs 255
 vaccines 261
 Injuries
 emergency care 244
 surgery 246
 Ink, paper
 chromatography 70
 Inlets, coastlines 287
 Input signal, amplifiers 349
 Insect-eating bats 167
 Insecta 132
 Insectivores, lizards 163
 Insects 154
 anatomy 156
 carnivorous plants 145
 classification 132
 endangered species 175
 pollination 146
 types 157
 Inselbergs 280
 Instep 181
 Instruments, surgical 246
 Insulation 407
 birds 164
 mammals 166
 Insulin
 diabetes 260
 discovery of 179
 genetic engineering 262
 pancreas 189
 Integers 360
 Integrated circuits
 337, 350-1
 computers 353
 diodes 346
 electronic circuits 338
 silicon 104
 Integument 147
 Intensive care,
 hospitals 245
 Intercostal lymph
 nodes 192
 Intercostal muscles 407
 Intercostal nerves 215
 Intercourse, sexual
 198, 199
 Interference 407
 constructive 54
 destructive 54
 electromagnetic
 radiation 48
 interference pattern 62
 wave behaviour 54-5
 International Union for
 the Conservation of
 Nature (IUCN) 175
 Internet 337, 354, 355
 Internodes, flowering
 plants 142
 Interphase, mitosis 126
 Interpreting data 19
 Intersections, set theory
 370, 371
 Intervertebral disks
 182, 183, 247
 Intestines
 amphibians 160
 annelid worms 152
 arachnids 155
 cells 122
 crustaceans 154
 digestion 199
 echinoderms 151
 fish 158
 gastropods 153
 human anatomy 196,
 197, 216, 219, 222
 ileocecal junction 219
 lizards 162
 parasites 152
 transplants 251
 Intine, pollen grains 146
 Intramuscular
 injections, drugs 255
 Intranets, computer
 networks 355
 Intravenous injections,
 drugs 255
 Introduced species 175
 Invertebrates 407
 arthropods 154-7
 classification 133
 endangered species 175
 evolution 268
 worms and
 mollusks 152-3
 Inverted images 53
 Io 316
 Iodide, formula 379
 Iodine 68, 110
 contrast X rays 241
 mass spectrometry 117
 molar mass 73
 periodic table 75, 110
 positron emission
 tomography (PET) 243
 starch indicator 89
 Ionic bonding 67, 78, 407
 lithium fluoride 78
 metals 76
 Ionosphere 267, 290
 Ions 40, 67, 407
 acids 84
 activity series 94
 alkali metals 98
 alkaline earth
 metals 100
 ammonia 106
 chemical analysis 116
 chemical reactions 80
 chlorine in water 111
 complex ions 81
 displacement
 reactions 94-5
 electrochemistry 96
 formula 379
 halogens 110
 heat 90
 hydronium 84
 ionic diameter 98
 macromolecules 76, 79
 mass spectrometry
 116, 117
 mole 72
 oxidation 82
 reduction 82
 salts 86, 87
 solutions 70
 transition metals 102
 Van de Graaff
 generators 41, 343
 Iridium 74
 Iris 144, 205
 Iron
 alloys 102
 catalysts 88, 107

- chemical reactions 69
 Earth's composition 270, 379
 Earth's magnetic field 41
 electromagnetism 44, 45
 extraction 76, 77
 formula 379
 hemoglobin 115
 inductors 544
 iron and sulphur mixture 69
 iron sulfide 68
 magnetism 40, 41
 on Mars 315
 melting and boiling points 32, 379
 meteorites 270
 ores 77
 oxidation number 82
 periodic table 74
 pyrites 68
 reactivity 68, 94
 rusting 82
 steel manufacture 105
 thermite reaction 91
 transition metals 102
 Iron oxide
 extraction of iron 76, 77
 glass 105
 on Mars 314
 thermite reaction 91
 Iron sulfide 69, 109
 Irrational numbers 360, 361
 Irregular bones 182
 Irregular galaxies 528
 Isahara test, color blindness 239
 Ischial tuberosity 222, 225
 Ischiorectal fossa 225
 Ischium 182, 183
 Islands
 atolls 289
 eyots 285
 island arcs 288
 sizes 382
 volcanic 275, 288
 Islets of Langerhans 179
 Isobars 293
 Isoceles triangles 392
 Isoclinal folds 277
 Isomers, carbon compounds 112
 Isotopes 407
 atomic number 72
 Italy, mathematics 358
 Iteration, fractals 372, 373
 IVF see In-vitro fertilization
 Ixodes ricinus 155
- JK**
 Jackson, Charles 257, 396
 Jacobson's organ,
- reptiles 162
 Jansky, Karl 297, 396
 Janssen, Pierre 379
 Japan
 mathematics 358
 plate tectonics 273
 Japan, Sea of 382
 Japan Trench 382
 Jaundice 257
 Jawless fish 158, 159
 classification 133
 Jaws
 human anatomy 185, 196, 206
 prostheses 255
 snakes 163
 Jeffreys, Alec 121
 Jejunum 196, 197, 217, 218, 219
 Jelly fungi, classification 131
 Jellyfish 150
 classification 132
 Jenner, Edward 257, 396
 Jet streams 291
 Jewel Cave 383
 Joints 182, 407
 arthropods 154
 ball-and-socket 183
 cartilage 182
 emergency care 245
 hinge 183
 pivot 183
 saddle 183
 skull 183
 X-ray imaging 241
 Joux, James Prescott 15, 396
 Joules 16, 377
 Journals, scientific 10, 11
 Junction field-effect transistors (JFET) 348
 Junctions, circuit symbol 339
 June solstice 271
 Jupiter 316-17
 asteroid belt 304, 314, 325
 data 384
 moons 385
 rings 308
 size 304, 305
 space probes 302, 303, 312
 Jurassic period 269
 K strategy, reproduction 169
 K2 385
 Kalahari Desert 383
Kalanchoe daigremontiana 126
 Kangaroos 167
 gestation period 380
 Kangchenjunga 383
 Kara Kum Desert 383
 Karyotype, human 263
 Kaus Anstralis 387, 389
 Kaus Borcalis 388, 389
 Kaus Meridionalis 389
 Keel, birds 164
 Kelvin, SI units 377
 Kelvin, William Thomson 15, 396
 Kelvin scale 32, 376, 407
 Kepler, Johannes 296-7, 396
 Kepler crater, Moon 311
 Keratin
 beaks 164
 nails 181
 Kerosine, fractional distillation 113
 Kestrel 165
 Kettle holes 285
 Keyboards, computers 352, 353
 Keyhole surgery 248
 Khone Falls 383
 al-Khwarizmi, Muhammed ibn Musa 358, 359, 396
The Book of Restoring and Balancing 358
 Kidneys
 amphibians 160
 birds 164
 dialysis 251
 fish 158
 gastropods 155
 human anatomy 216, 220
 lizards 162
 mammals 166
 transplants 250, 251
 urinary system 198
 Kilby, Jack 337
 Kilimanjaro 382
 Killer cells, immune system 260
 Kilogram meters per second 23
 Kilograms 18, 376, 377
 Kilohms, resistors 340
 Kiloliters 376
 Kilometers 376, 377
 Kinetic energy 16, 407
 brakes 25
 energy transfer 17
 generators 46
 heat 32, 90
 heat transfer 33
 solids 34
 X rays 49
 Kirckhoff, Gustav Robert 67, 396
 Kites (birds) 165
 Kitt Peak National Observatory 306
 Kiwi 165
 Klystrons 336
 Klyuchevskaya Sopka 383
 Knees 181
 artificial joints 253
 joint 183
 Knuckles 228, 229
 artificial joints 253
- Koalas 167
 Koch, Helge von 372
 Koch, Robert 257, 396
 Koch curves 372
 Kochab 386
 Korea, mathematics 358
 Krebs, Hans Adolf 121, 396
 Krebs cycle 121, 124, 407
 Krypton 75
 Kuiper Belt 304, 320, 321
 Kuril-Kamchatka Trench 382
- L**
 Labium majus 224
 Labium minus 224, 225
 Laboratories 10, 11
 chemical analysis 116
 medical diagnosis 259
 Labor, childbirth 237
 Lacerta constellation 387, 388
 Lacrimal bone 206
 Lacrimal glands 200
 Lacrimal sac 200
 Lacrimomaxillary suture 206
 Lactation 208
 Lacteal 197
 Lactic acid 124
 Lactiferous ducts 208
 Lactiferous sinuses 208
 Ladybugs, metamorphosis 157
 Lagoon Nebula 389
 Lagoons
 atolls 289
 coastlines 286
 Lakes 280-1
 acid rain 174
 glacial erosion 285
 pollution 174
 sizes 385
 water cycle 172
 Lamarck, Jean-Baptiste de 120, 396
 Lambdoidal suture 206
 Lambert-Fisher Ice Passage 383
 Lamellae
 chloroplasts 148
 fish 158
 Lamina
 leaves 144, 145, 148
 seaweeds 138
 Lamina of vertebral arch 211
 Lampetra fluviatilis 159
 Lampreys 159
 classification 133
 Lamps 50
 circuit symbol 339
 Lampshells, classification 133
 Lamrechtsofen 383
 Lancelets, classification 133
 Landers, space probes 302, 303
 Landforms, geological science 266
 Landscapes, rocky 280-1
 Landslides 276
 Landsteiner, Karl 237, 396
 Langerhans, Paul 179, 396
 LANs (Local Area Networks) 335
 Lanthanides, periodic table 74-5, 102
 Lanthanum 74
 Laparoscopes 248
 Laptop computers 354
 Larches 140
 Large Electron Positron (LEP) collider 61
 Large Hadron Collider (LHC) 60, 61
 Large intestine 196, 197, 216, 219, 222
 Large Magellanic Cloud 329, 388, 389
 Large-scale integration (LSI) 337
 Larkspur 143
Larus argentatus 171
 Larvae
 amphibians 160
 metamorphosis 156, 157
 Laryngeal prominence 194, 205
 Laryngitis 381
 Laryngopharynx 204
 Laryngoscopes 238
 Larynx (voice box)
 amphibians 160
 artificial 253
 cartilage 204, 205
 human anatomy 194, 215
 Lascar 385
 Lasers 56
 surgery 248, 249
 Lasing medium 56
 Latent heat 407
 melting a substance 32, 33
 Lateral buds, flowering plants 142
 Lateral cartilage, nose 205
 Lateral epicondyle 229
 Lateral line, fish 159
 Lateral malleolar network 232, 233
 Lateral moraine 282, 283
 Lateral plantar nerve 186
 Lateral roots 149
 Lateral sulcus 206, 207
 Lateral ventricle, brain 207
 Lather, soap 100
 Latin names 150
 Latitude 407
 Laurasia 269, 275
 Lava
 igneous rocks 278
 Moon 310, 311
 oceanic crust 288
 volcanoes 275
Lavatera arborea 142
 Lavoisier, Antoine 67, 396
 Lawrencium 75
 Laws
 natural 9
 scientific 9
 LCDs see Liquid crystal displays
 LDRs see Light-dependent resistors
 Lead 32
 flame tests 116
 lead shot 68
 periodic table 75, 104
 reactivity 94
 solder 105
 Lead iodide 80
 precipitation reaction 8
 Lead nitrate 80
 precipitation reaction 8
 Lead oxide 81, 102
 Lead pencils 104
 Lead sulfide 68
 Leaf succulents 145
 Leafy liverworts 138
 Leaves
 carnivorous plants 145
 conifers 140
 cotyledons 147
 cycads 140
 dicots 143
 ferns 159
 flowering plants 142, 144
 ginkgo 140
 gymetophytes 140
 herbaceous flowering plants 142
 horsetails 139
 internal anatomy 149
 monocots 143
 photosynthesis 100, 148
 pine trees 141
 plant-transport systems 148, 149
 succulents 145
 types 144
 LEDs see Light-emitting diodes
 Leeches 152
 classification 132
 Leeuwenhoek, Antony van 120, 121, 396
 Legionella 259
 Legionnaire's disease 259
 Legs
 arachnids 155
 arthropods 154
 birds 164, 165
 bones 182
 cheetahs 167
 crocodilians 163
 human anatomy 180
 joints 183
 lower leg 252-5
 mammals 166
 muscles 185, 230-3
 prostheses 253

- tadpoles 161
 thighs 181, 250-1
 Leibniz, Gottfried
 Wilhelm 337, 359, 396
 Lemaître, Georges
 297, 396
 Lemurs 167
 Lena, River 383
 Length
 conversion tables 377
 measurements 18, 376
 SI units 377
 Lens-cornea, compound
 eyes 156
 Lenses 52-3, 407
 artificial eye lenses
 252, 253
 binoculars 52
 endoscopes 248
 eyes 52, 205
 telescopes 298
 Lenticels, flowering
 plants 142
 Leo constellation 386, 389
 Leonardo da Vinci 178, 396
 Lepas 154
 Lepus constellation 386,
 388, 389
 Lesser occipital
 nerve 202
 Lesser omentum 217
 Lesser Water Snake
 constellation 388
 Lettuce slug 153
 Levées 285
 Levers, three classes 27
 Libra constellation 386,
 388, 389
 Lichens
 classification 131
 structure 137
 symbiosis 136, 137
 Lienorenal ligament 219
 Life 270
 creation of 268
 creationism 128
 evolution 128-9
 on Mars 303, 314, 323
 Miller-Urey experiment
 121
 origins of 121
 polymers 114
 Life science 6, 118-67
 amphibians 160-1
 arthropods 154-7
 birds 164-5
 cell functions 124-5
 cells and cell structure
 122-3
 classification 130-3
 data 380
 evolution 128-9
 fish 158-9
 flowering plants 142-7
 fungi 136-7
 history 120-1
 mammals 166-7
 microorganisms 134-5
 nonflowering plants
 138-41
 photosynthesis and
 plant-transport
 systems 148-9
 reproduction and
 heredity 126-7
 reptiles 162-3
 sponges, cnidarians
 and echinoderms 150-1
 worms and
 mollusks 152-3
 Life support systems,
 ambulances 244
 Life zones 168
 Lifespan, animals 380
 Lift, birds' flight 165
 Ligament of vena
 cava 217
 Ligaments 182, 407
 Ligamentum
 arteriosum 214
 Ligamentum venosum 217
 Ligase enzymes 262
 Light
 additive process 51
 as a catalyst 88
 color 50
 constructive
 interference 55
 destructive
 interference 54, 55
 Doppler shift 301
 electromagnetic
 radiation 48
 electromagnetic
 spectrum 49, 299
 electrons 56
 energy 15, 16, 90
 fireworks 101
 fluorescence 56
 laser surgery 249
 lasers 56
 lenses 55
 mirrors 55
 Newton's theories 14
 photons 62
 photosynthesis 100
 phototherapy 257
 polarized 54, 55
 quantum physics 15, 62
 radiation from hot
 objects 49
 reflection 52-3
 refraction 52
 space-time distortions 63
 spectrometers 297
 speed of 52
 subtractive process 51
 Sun 307
 telescopes 298
 theory of relativity 63
 wave theory 14
 see also Sunlight
 Light bulbs 43
 color 50
 electric circuits 43
 Light curve, variable
 stars 325
 Light-dependent resistors
 (LDRs) 340, 341
 Light-emitting diodes
 (LEDs)
 color 50
 digital thermometer 19
 diodes 346, 347
 light-dependent
 resistors 341
 Light years 407
 Lightning 292
 lightning conductors 47
 nitrogen cycle 172
 temperature 32
 Lignin, woody flowering
 plants 142
 Lilies 145
 glory lily 144
 Liliopsis 151, 142
 Limbs
 arthropods 154
 evolution 129
 mammals 166
 Limbs (geological), folds
 277
 Lime, slaked 101
 Lime tree, common 144
 Limestone
 acid on 87
 caves 281
 formation 279
 formula 379
 gorges 281
 mineral water 86
 steel manufacture 103
 weathering 280
 Limewater 83, 116
 Limiting friction 24, 408
 Limpets 171
 Line graphs 368
 Linea alba 209, 223, 224
 Linea arcuata 209
 Linear integrated
 circuits 350
 Lines, geometry 364-5
 Lingual tonsils 204, 205,
 215
 Linnaeus, Carolus 396
 classification 120, 121,
 130
 Lintels, coastlines 287
 Lion constellation 386
 Lions, gestation period
 380
 Lippershey, Hans 297, 396
 Lips 181, 196
 Liquid crystal displays
 (LCDs) 54, 55
 Liquid pressure, formula
 378
 Liquids 36-7
 capillary action 36
 crystallization 16
 dissolving 16
 distillation 70, 71
 drops and bubbles 36
 evaporation 16
 gases as 90
 meniscus 36
 mixtures 70
 particles 32
 pressure 36, 37
 supercooled 32
 temperature 32
 upthrust 37
 Liquefaction 32
 Lister, Joseph 237, 396
 Litharge 102
 Lithification 278
 Lithium
 atomic diameter 98
 cation 98
 ionic bonding 78
 ionic diameter 98
 periodic table 74, 98
 Lithium fluoride 78
 Lithosphere 272-3, 408
 Litmus paper
 ammonia fountain 95
 reaction of sodium with
 water 98
 Liters 376, 377
 Little Bear constellation
 386
 Little Dog constellation
 386
 Little finger 228
 Liver
 amphibians 160
 bile 196, 216, 217
 birds 164
 coronary ligament 217
 fish 158, 159
 functions 217
 hepatic portal system
 219
 human anatomy 216, 217
 lizards 162
 malaria 259
 mammals 166
 research 179
 structure 217
 transplants 251
 Liverworts 158
 classification 130
 Lizards 163
 anatomy 162
 cladistics 133
 Llamas, energy
 requirements 380
 Load 26
 levers 27
 Lobes, lungs 194, 215
 Lobster claws (flower)
 144
 Lobsters
 anatomy 154
 classification 132
 food webs 171
 Lobules
 breasts 208
 testes 222
 Local Group 328
 data 384
 Lockyer, Norman 379
 Locusts, black 144
 Logarithmic spirals,
 golden rectangle 361
 Logarithms 359
 Logic 370-1
 deduction 8
 mathematics 358, 359
 Logic gates 337, 370, 390
 Long bones 182
 Long-wave radio 48
 Longevity, animals 380
 Longitude 408
 Longitudinal fissure,
 brain 207
 Longitudinal waves 30
 Longshore drift 287
 Loop of Henle 198
 Lorenz, Edward 372
 Lorenz strange attractor
 372
 Loudspeakers 31
 transformers 345
 Low pressure
 rarefactions 31
 weather 292
 Lower, Richard 179, 396
 Lozenges, drugs 255
 Lubricants, tablets 254
 Lubrication 24, 25
 Lumbar nerves 186
 Lumbar plexus 186
 Lumbar vertebrae
 human anatomy 182,
 183, 211, 221
 mammals 166
 Lumbosacral joint 211
 Lumen
 blood vessels 190
 esophagus 215
 trachea 215
 uterus 199
 Luminescence 408
 comets 322
 electrons 56
 fluorescence 56
 phosphorescence 57
 Luminosity 408
 stars 300, 324, 325
 Luminous intensity, SI
 units 377
 Luna 1 297
 Lunar eclipses 296, 310,
 311, 385
 Lunar phases 310
 Lungs
 allergies 261
 amphibians 160
 arachnids 155
 birds 164
 computerized
 tomography 241
 cystic fibrosis 237
 drug inhalers 255
 gastropods 153
 heart-lung machines 247
 human anatomy 182,
 200, 213, 214
 lizards 212
 mammals 166
 measuring lung
 function 261
 pleurae 212
 pulmonary circulation
 190, 191
 respiratory system 194-5
 retractors 247
 thoracic cavity 212
 transplants 251
 Lupus constellation 386,
 388
 Luster, metals 76
 Lutetium 75
 Lycophyta 131
 Lymph 192, 193
 Lymph nodes 192
 B cells 250
 structure 193
 Lymphatic capillaries
 192, 193
 Lymphatic ducts 192
 Lymphatic system 192-3
 discovery of 179
 Lymphatic trunks 192
 Lymphatic vessels 192,
 193
 Lymphocytes
 antibodies 191, 193
 B cells 250
 Human
 Immunodeficiency
 Virus (HIV) 258
 immune system 193, 260
 lymphatic system 192
 T cells 250
 transplant and graft
 rejection 250
 Lynx constellation 386,
 389
 Lyra constellation 386,
 388
 Lyre constellation 386
 Lysosomes 122

M

- Macaca mulatta 166
 Machines 26-7
 Mackenzie-Peace River
 385
 Mackerel 159
 McKinley, Mount 382
 McNath-Pierce facility 306
 Macromolecules 408
 crystals 79
 ionic bonding 76, 78
 Macrophages
 immune system 193,
 260
 lymphatic system 192
Macropus rufogriseus 167
 Macroscopicules, Sun 307
 Madagascar 382
 Madrepores,
 echinoderms 151
 Magellan space probe
 312, 315

- Magellanic Clouds 329
 Magenta
 additive process 51
 subtractive process 51
 Maggots 175
 Magma 270, 408
 mid-oceanic ridges 288, 289
 rock cycle 278
 volcanic islands 275
 volcanoes 275
 Magnesite bricks 105
 Magnesium
 atoms 77
 burning 77
 in chlorophyll 100
 ductility 76
 in Earth's crust 579
 fireworks 101
 formula 379
 periodic table 74, 100
 reactivity 94
 reactivity with dilute acids 95
 sea water 288
 spectral absorption lines 301
 thermite reaction 91
 Magnesium oxide 77
 cathode-ray tubes 56, 57
 force lines 44
 mass spectrometry 117
 particle accelerators 60
 radio waves 48
 solenoids 45
 Magnetic fields 408
 cathode-ray tubes 56, 57
 Earth's 271
 force lines 44
 inductors 344
 mass spectrometry 117
 particle accelerators 60
 pulsars 330
 radio waves 48
 solenoids 45
 tuned circuits 345
 Magnetic resonance
 imaging (MRI) 242
 brain scans 234-5, 242
 invention of 179, 237
 Magnetism 40-1
 electromagnetic radiation 48-9
 electromagnetism 44-5
 energy 15
 Sun 307
 sunspots 306
 Magnetometers, space probes 302, 303
 Magnetopause 271
 Magnetosphere 271
 Magnetotail 271
 Magnets
 compasses 41, 44
 electricity generation 46
 electromagnets 45
 loudspeakers 31
 separating iron from sulfur 69
 Magnification
 magnifying glasses 55
 telescopes 298
 Magnitude, stars 300, 301, 324, 325
 Magnoliopsida 151, 142
 Maidenhair tree 140
 Main-sequence stars 325, 326, 327, 408
 Mains transformers 545
 Major alar cartilage, nose 203
 Makalu 385
 Malacostraca 132
 Malaria 259
 Mallard, speed 380
 Malleability, metals 76
 Malleus 203
 Mallow, tree 142
 Malpighi, Marcello 179, 396
 Malpighian tubules, insects 156
 Mammalia 150, 153
 Mammals 166-7
 cladistics 133
 classification 150, 153
 endangered species 175
 evolution 129, 269
 tagging 175
 Mammary glands 166, 208
 Mammograms 241
 Mammoth Cave System 385
 Manatees 167
 Mandelbrot, Benoit 359, 372, 396
 Mandelbrot set 356-7, 359, 372
 Mandibles 196
 human skeleton 182, 183, 206
 mammals 166
 muscles 201, 204, 205
 Mandibular angle 206
 Mandibular condyle 206
 Mandibular notch 206
 Manganese
 periodic table 74
 preparation of oxygen 108
 Manganese chloride 111
 Manganese oxide
 alkaline dry cells 96
 bleaching 111
 preparation of chlorine 110
 Manta rays 159
 Mantle
 earthquakes 274
 Earth 270
 Jupiter 317
 Mars 314
 Moon 311
 Neptune 320
 plate tectonics 272-3
 Venus 313
 Mantle cavity, gastropods 155
 Manubrium 182
 Maps
 radar mapping 513
 weather maps 295
 Marble 80, 81
 March equinox 271
Marchantia polymorpha 158
 Mardalsfossen 383
 Mare Frigoris 311
 Mare Humorum 311
 Mare Ibrum 311
 Mare Ingenii 311
 Mare Moscoviense 311
 Mare Nubium 311
 Mare Serenitatis 311
 Mare Smithii 311
 Mare Tranquillitatis 311
 Maria, Moon 310, 311
 Mariana Trench 382
 Marine worms 152
 classification 132
Mariner 10 space probe 312
 Markab 387, 388
 Markeb 389
 Marking animals, conservation 175
 Marrow see Bone marrow
 Mars 314-15
 data 384
 life on 315, 314, 323
 moons 385
 size 305
 space probes 10, 297, 302, 303
 Marsupial mole 167
 Marsupialia 167
 Marsupials 166, 167
 Mass 408
 Avogadro's number 73
 centripetal force 28
 chemical reactions 80, 81
 conservation of 81
 conversion tables 377
 lifting with pulleys 27
 measurement 18, 376
 molar mass 73
 momentum 25
 Newton's Laws 22
 oscillation 30
 particle physics 60
 relative atomic mass (RAM) 72
 relative molecular mass (RMM) 72
 SI units 377
 theory of relativity 63
 Universe 332, 333
 Mass spectrometry 116, 117
 Mast cells 260, 261
 Mastoid process 206
 Matar 387
 Matches, activation energy 90
 Mathematics 7, 356-73
 algebra 362-3
 chaos theory and fractals 372-5
 coordinates and triangles 366-7
 data 392-3
 geometry 364-5
 history 358-9
 history of astronomy 296
 logic and sets 370-1
 numbers 360-1
 probability and statistics 368-9
 symbols 393
 Matrix, nail 181
 Matter 16-17, 408
 atoms 56-7
 Big Bang 332
 Brownian motion 16
 crystallization 16
 dissolving 16
 evaporation 16
 heat energy 32
 historical theories 66
 mass 18
 particle physics 60-1
 phlogiston theory 66
 states of 32
 temperature 32
 Maxilla 183, 204, 206
 Maxwell, James Clerk 15, 396
 Maya, mathematics 358
 Mean, statistics 368, 369
 Meanders 284, 285
 Measurement 18-19, 376-7
 acceleration 22, 23
 distance 18
 electric current 42
 force 20
 frequency 31
 gas pressure 39
 heat 18
 length 18
 limiting friction 24
 liquid pressure 37
 mass 18
 momentum 25
 pressure 21
 radioactivity 58
 speed 22, 23
 temperature 32
 thermal expansion 34
 time 18
 turning force 21
 weight 18
 width 18
 Mechanical advantage 26
 Mechanical energy 17
 "Mechanical" ("mechanistic") philosophy 14
 Mechanics, history 14
 Medial arcuate ligament 221
 Medial epicondyle of humerus 226, 228
 Medial moraine 282, 283
 Medial plantar nerve 186
 Median nerve 186, 226, 228
 Medical imaging 240-3
 Medical photography 49
 Medical science 7, 178, 234-63
 data 381
 history 66, 236-7
 Mediterranean Sea, size 382
 Medium-voltage-control transistors 349
 Medium-wave radio 48
 Medulla
 adrenal glands 189
 kidneys 198
 Medulla oblongata 187, 207
 Medullary cavity, bone 182
 Medullary cord, lymph nodes 193
 Medullary sinus, lymph nodes 193
 Medusae 150
 Megrez 387
 Meiosis 127
 Meissner's corpuscle 181
 Melting
 states of matter 32
 melting points 33, 78, 379, 408
 Meltwater, ice caves 282
 Membrane, cell 122
 Membranous urethra 225
 Memory
 brain 187
 computers 352
 Mendel, Gregor Johann 121, 126, 396
 Mendelevium 75
 Mendeleyev, Dmitri 396
 Mendelian ratio 15, 67
 Mendelian table 127
 Meninges 186
 Meningitis 381
 Meniscus 36, 408
 downward 30
 upward 36
 Menkalinan 389
 Menkar 387, 388
 Menkent 389
 Mensa constellation 388, 389
 Menstrual cycle 225, 408
 Menstrual periods 256
 Menstrual phase 225
 Mental foramen 206
 Mental protuberance 206
 Merak 387
 Mercalli scale, earthquakes 383
 Mercury (element) 68
 melting and boiling points 379
 meniscus 36
 periodic table 75
 reactivity 94
 sphygmomanometer 239
 thermometers 19, 71, 239
 Mercury (planet) 312
 data 384
 orbit 304
 size 305
 space probes 312
 Mercury cathode process, sodium hydroxide 99
 Mercury oxide 68, 69
 Merganser 164
 Meridians, acupuncture 236
 Meristem tissue 126
 Merostomata 133
 Merozoites 259
 Merychippus 129
 Mesas 280, 281
 Mesentery 218, 219
 Mesocarp, succulent fruit 147
 Mesohippus 129
 Mesohyal, sponges 150
 Mesons 408
 particle physics 60
 theory of relativity 63
 Mesophyll 149
 Mesopotamia
 glassworks 67
 mathematics 358, 359
 Mesosphere 290
 Mesozoic era 269
 Messenger RNA (mRNA) 125
 Messier, Charles 328
 Metabolic rate 408
 birds 164
 Metabolism 124
 Metacarpals
 birds 164
 human skeleton 182, 228, 229
 joints 183
 Metacarpophalangeal joints 228
 Metacarpus 228
 Metal-oxide field-effect transistors (MOSFET) 348
 Metallized film capacitors 343
 Metallurgy, history 66
 Metals 76-7
 activity series 94-5
 alchemy 66
 alkali metals 98-9
 alkaline earth metals 100-1
 artificial body parts 252, 253
 atoms 76
 catalysts 88
 cations 76
 characteristics 76
 color 76
 compounds 76

- corrosion 94, 95
 electric circuits 42
 electrodes 97
 electrolysis 67
 electromagnetic radiation 49
 electrons 76
 electroplating 96, 97
 extraction 77
 flame tests 116
 macromolecules 76
 ores 76
 oxides 76
 and oxygen 77
 periodic table 74-5
 reactive metals 76
 salts 86
 thermite reaction 90, 91
 transition metals 102-5
 welding 52, 90, 91
- Metamorphic rocks 408
 formation 278-9
 fossils 269
- Metamorphosis 408
 amphibians 160
 frogs 161
 insects 156, 157
- Metaphase, mitosis 126
- Metatarsal bones 182, 232
- Metatarsus, spiders 155
- Meteor Deep 382
- Meteor showers 322, 325
- Meteorites 525
 atmosphere and 290
 impact craters 508, 509, 510, 511
 materials 270
- Meteoroids 504, 522-5
- Meteorology, history 267
- Meteors 290, 322, 325
- Methane
 atomic structure 112
 in comets 322
 fractional distillation 113
 on Jupiter 517
 on Neptune 320
 on Uranus 519
- Methanol 379
- Methyl orange
 indicators 85
- Meters 18, 376, 377
- Meters per second 22, 23
- Meters per second per second 22, 23
- Metric tons 376, 377
- Metric units 376-7
- Mexican hat plant 126
- Mexico, Gulf of 382
- mF see Microfarads
- Miaplacidus 389
- Mice
 energy requirements 580
 gestation period 580
 lifespan 580
 trophic pyramid 170
- Michelangelo crater, Mercury 312
- Michigan, Lake 385
- Microbody, plant cells 123
- Microchips see Integrated circuits
- Microfarads (mF) 342
- Micrometers 408
 measuring thermal expansion 34
- Microorganisms 134-5, 408
 discovery of 120
 genetic engineering 262
 germ theory 237
 infection and disease 258-9
- Microphones 51
 alternating current 358
 amplifiers 349
- Microphyle, conifers 141
- Microprocessors
 integrated circuits 350
 invention of 357
 myoelectric arms 253
 personal computers 352
- Micropyle 147
- Microscope constellation 388
- Microscopes
 atomic force 78
 electron 120, 121
 invention of 120, 121, 179
 traveling 18
- Microscopium
 constellation 388
- Microsoft 357
- Microsurgery 248, 249
- Microtubules,
 plant cells 123
- Microwave radiation
 48, 408
 computer networks 354
 electromagnetic spectrum 299
 klystrons 356
 radar mapping 315
- Mid-Atlantic Ridge 275
- Mid-ocean ridges 288, 289
- Midbrain 187
- Middle Ages 8-9
 life sciences 120
 mathematics 358
 medicine 256
 physics 14
- Middle finger 228
- Middle phalanx 228, 232
- Midgut
- Arachnids 155
 insects 156
- Mildews 156
- Miles 376, 377
- Milk
 colloid 70
 mammals 166
 milk-secreting glands 208
- Milky Way Galaxy 324
 center of 351
 images of 299, 329
- radio astronomy 297
 spiral galaxy 328
- Miller, Stanley Lloyd 121, 396
- Miller-Urey experiment 121
- Milliliters 376
- Millimeters 376
- Million 377
- Millipedes 154, 156, 157
 classification 132
- Milne, John 267, 396
- Milwaukee Deep 582
- Mimosa 389
- Mineral water 86, 87
- Minerals 278-9, 408
 Mohs' scale of hardness 267, 279
 sea water 288
- Miniaturization,
 electronics 357, 350
- Minimally invasive surgery 248-9
- Minims 376
- Mintaka 324, 386
- Mira 387, 388
- Mirach 387, 388
- Miranda 319
- Mirfak 387, 388
- Mirrors
 laryngoscopes 238
 reflection and refraction 52, 55
 telescopes 296, 298
- Mirzam 386, 389
- "Missing link", fossils 128
- Mississippi-Missouri River 285, 383
- Mites, classification 155
- Mitochondria 408
 animal cells 122
 euglenoids 135
 Krebs cycle 124
 plant cells 123
- Mitosis 126
- Mitral valves 191
- Mixing desks,
 potentiometers 341
- Mixtures 70-1, 408
 chemical analysis 116
 colloids 70
 decomposition 80
 dehydrating agents 92
 distillation 71
 filtration 70, 71
 hydrocarbons 112
 iron and sulfur 69
 solutions 70
 suspensions 70
- Mizar 387
- Möbius strip 365
- Models, molecular 68
- Modems, computer networks 354, 355
- Modern physics 15, 62-3
- Modus tollendus ponens 371
- Mohorovicic
- discontinuity 270
- Mohs, Friedrich 267, 396
- Mohs' scale of hardness 267, 279
- Molarity 75
- Molars
 carnivores 166
 herbivores 166
 human anatomy 196, 197
- Molecular 408
- Molecular orbitals 408
 covalent bonds 79
 electron shells 78
- Molecules 72-3, 408
 absolute zero 32
 acids 84
 anabolism 124
 bonding 78
 Brownian motion 16
 capillary action 36
 carbon 114
 chaos theory 372
 chloroethene 115
 chlorophyll 100
 compounds 68
 diatomic 77, 80
 drug development 254
 evaporation 16
 extraction of metals 77
 gas molar volume 73
 gases 38
 heat 32, 90
 induction 40
 macromolecules 76
 matter 16
 models 68
 moles 72
 polymerization 114
 precipitation reaction 8
 relative molecular mass (RMM) 72
 surface catalysis 88
 water 92
- Moles (animals) 166
- Moles (measurement) 408
- Avogadro's number 75
 gas molar volume 75
 molar mass 75
 molar solutions 75
 SI units 72, 377
- Mollusca 132, 152
- Mollusks 152-3
 classification 132
- Molten sulphur 109
- Molybdenum 74
- Moment, turning force 21, 408
- Momentum 14, 23
 angular 29
 formula 378
 oscillation 30
- Mondino de Luzzi 179, 396
- Monera 130
- Monerans, classification 131
- Mongefossen 383
- Monitoring childbirth 257
- Monitors, computers 352, 353
- Monkeys 166, 167
- Monoceros constellation 386, 389
- Monoclinical folds 277
- Monoclinic (α) sulphur 109
- Monoclinic system,
 crystals 35
- Monocotyledonous
 plants (monocots) 408
 classification 131
 flowers 143
 leaves 143, 144
- Monocytes 191
- Monogenea 132
- Monohydrates 95
- Monomers 115
- Monosaccharides 114
- Monotremata 167
- Monotremes 166, 167
- Monus pubis 224, 225
- Montes Apenninus, Moon 311
- Moon 310-11
 craters 310, 311, 325
 gravity 22, 25
 historical theories 266
 history of astronomy 296
 lunar eclipses 296, 385
 moonquakes 311
 solar eclipses 306
 space probes 302
 tidal power 47
- Moons 308
 data 385
 Jupiter 316
 Mars 514
 Neptune 320
 Pluto 320, 321
 Saturn 318
 Uranus 518, 319
- Moraine 282, 285
- Morels, classification 131
- Morning Star 312
- Mortar 100, 101
- Mosquitoes, malaria 259
- Mosses 158
 classification 130
- Motherboards,
 computers 353
- Moths 157
 natural selection 128
 wings 156
- Motile 408
- Motion
 amoebas 135
 Brownian 16
 circular 28-9
 energy 15, 17
 formula 378
 friction 24
 gas particles 38
 Laws of 14
 Newton's Laws 22-3
 oscillation 30
 precession 29
 swimming 159
- Motor neurons 184, 186, 187
- Motorcycles
 brakes 25
 centripetal force 28, 29
- Molds 134, 135
 classification 131
- Molting 408
 metamorphosis 156
- Mountains
 formation of 277
 glaciers 282
 highest 383
 historical theories 266
 life zones 168
 ocean floor 288
 plate tectonics 272, 276
- Mouse, computers 352
- Mouse (animal) see Mice
- Mouths
 annelid worms 152
 cells lining 122
 cnidarians 150
 diagnosis 238
 echinoderms 151
 fish 158, 159
 gastropods 155
 jawless fish 159
 mammals 166
- Movable joints 185
- Movement see Motion
- MRI see Magnetic resonance imaging
- Mucous membranes
 asthma 261
 suppositories 255
 trachea 215
- Mucus 409
 amphibians 160
 fish 158
- Mud flats 286
- Mud pools 275
- Muddy water, filtration 71
- Mudpuppies 160
- Muliphen 389
- Multicellular 409
- Multimeters 358, 359, 340
- Multiple sclerosis (MS)
 autoimmune disease 260
 magnetic resonance imaging (MRI)
 scanning 242
 symptoms 381
- Multiplication,
 computers 370
- Mummies 178
- Muscles 184-5
 abductor digiti minimi 228, 229, 252, 253
 abductor hallucis 232
 abductor pollicis brevis 228
 abductor pollicis longus 228, 229
 adductor longus 185, 230
 adductor magnus 185,

- 222, 225, 251
 adductor minimus 251
 adductor pollicis 228
 anastomosis, cardiac 184
 ansa cervicalis 202
 anterior scalene 201
 arrector pili 181
 arthropods 154
 biceps brachii 185, 208, 209, 228
 long head 226, 227
 short head 226
 biceps femoris 185, 230, 231, 253
 birds 164, 165
 brachialis 185, 226, 227
 brachioradialis 226, 227, 228
 buccinator 200, 201
 bulbospongiosus 222, 225
 cardiac 184, 191
 cells 122
 coracobrachialis 226
 cremasteric 222
 cricothyroid 205
 deltoid 185, 201, 202, 203, 205, 209, 210, 226, 227
 depressor anguli oris 200, 201
 depressor labii inferioris 200, 201
 depressor septi 200
 digastric 201, 202, 205
 dorsal interosseus foot 252, 253
 hand 229
 drug injections 255
 extensor 185
 extensor carpi ulnaris 228, 229
 extensor digiti minimi 229
 extensor digitorum brevis 252
 extensor digitorum longus 252, 253
 extensor hallucis brevis 252, 253
 extensor hallucis longus 252, 253
 extensor pollicis brevis 229
 extensor retinaculum ankle 252, 253
 wrist 228, 229
 external intercostal 208, 209, 210, 212, 215
 external oblique 185, 208, 209, 210, 212, 216, 220, 221, 223, 224, 250
 fish 158
 flexor 185
 flexor carpi radialis 228
 flexor carpi ulnaris 228, 229
 flexor digiti minimi brevis 252
 flexor digitorum brevis 252
 flexor digitorum longus 185, 235
 flexor digitorum superficialis 228
 flexor hallucis longus 253
 flexor pollicis brevis 228
 flexor retinaculum 228, 253
 frontalis 185, 200, 201, 204
 galea aponeurotica 200, 201, 203
 gastrocnemius 185, 230, 231, 252, 253
 gemellus 251
 genioglossus 204
 geniohyoid 204
 gluteus maximus 185, 222, 223, 224, 225, 250, 251
 gluteus medius 185, 223, 224, 251
 gracilis 185, 222, 225, 230, 231, 253
 iliacus 221, 250
 female pelvic region 224
 male pelvic region 222
 iliocostalis 210
 iliopsoas 185, 250
 inferior gemellus 251
 inferior oblique 203, 204
 inferior rectus 205
 infraspinalis 185, 210, 226, 227
 insects 156
 intercostal breathing 194, 195
 external intercostal 205, 208, 209, 210, 212, 215
 internal intercostal 209, 212, 215
 internal oblique 208, 209, 210, 216, 220, 221, 223, 224
 interosseus 184
 foot 252, 253
 hand 228, 229
 plantar 252
 involuntary 184
 ischiocavernosus 222, 225
 lateral malleolus 252, 253
 lateral rectus 203, 204
 latissimus dorsi 185, 208, 209, 210, 226, 227
 levator anguli oris 200
 levator ani 222, 225
 levator labii superioris 200, 201
 levator labii superioris alaeque nasi 200, 201
 levator palpebrae superioris 200
 levator scapulae 201, 203, 204, 210, 227
 longissimus 210
 masseter 185, 200, 201
 medial malleolus 252, 253
 mentalis 200, 201
 middle scalene 201
 mylohyoid 201, 204, 205
 nasalis 185, 200, 201
 obturator internus 251
 occipitalis 185, 201, 205
 omohyoid 201, 202, 205
 orbicularis oculi 185, 200, 201, 202, 205
 orbicularis oris 185, 200, 201, 202, 203, 204
 palmaris longus 228
 pectineus 185, 250
 pectoralis major 185, 201, 202, 205, 208, 209, 212, 226
 pectoralis minor 209, 212, 226
 perineus 225
 peroneus brevis 185, 252, 253
 peroneus longus 185, 252, 253
 piriformis 251
 plantar interosseus 252
 plantaris 185
 platysma 185, 200, 201, 202
 posterior auricular 205
 posterior scalene 201
 procerus 200
 pronator teres 228
 psoas major 221, 223, 224, 250
 pyramidalis 209
 quadratus femoris 251
 quadratus lumborum 221
 rectus abdominis 208, 209, 212, 216, 220, 221, 223, 224
 rectus femoris 185, 250
 research 179
 rhomboid major 205, 208, 210, 227
 rhomboid minor 205, 208, 210
 risorius 200, 202
 rotator cuff 226, 227
 sartorius 185, 250, 251
 scalene 201
 scalenus anterior 204
 scalenus medius 204
 scalenus posterior 204
 semimembranosus 185, 250, 251, 253
 semispinalis capitis 185, 201, 205, 204
 semitendinosus 185, 251, 253
 serratus anterior 185, 208, 209, 210, 212, 226
 serratus posterior inferior 210
 serratus posterior superior 210
 skeletal 184, 185
 smooth 184
 snakes 165
 soleus 185, 252, 253
 spinalis 210
 splenius capitis 185, 201, 205, 204
 splenius cervicis 205, 210
 sternocleidomastoid 185, 201, 202, 203, 204, 205
 sternohyoid 201, 202, 205
 sternothyroid 201, 202
 stylohyoid 201
 subclavius 209
 subcostales 221
 subscapularis 226
 superior gemellus 251
 superior longitudinal of the tongue 204
 superior oblique of the eye 205
 superior rectus 205, 204
 suprascapularis 226, 227
 temporalis 185, 200, 201, 205, 204
 tensor fasciae latae 250
 teres major 185, 208, 210, 226, 227
 teres minor 185, 208, 210, 226, 227
 thyrohyoid 201, 205
 tibialis anterior 185, 252, 253
 tibialis posterior 253
 trachealis 215
 transverse perineus 222, 225
 transversus abdominis 209, 216, 220, 221, 223, 224
 trapezius 185, 201, 202, 203, 204, 205, 208, 210, 226, 227
 triceps brachii 185, 208, 209, 229
 lateral head 210, 227
 long head 210, 226, 227
 medial head 226, 227
 vastus lateralis 185, 250, 251
 vastus medialis 185, 250
 voluntary 184
 zygomaticus major 200, 201, 202
 zygomaticus minor 200, 201, 202
 Muscular dystrophy 263, 381
 Musculocutaneous nerve 186
 Mushrooms 156
 classification 131
 life cycle 157
 structure 137
 Muslims 14
 Mussels 152
 food webs 171
 Mutations, genetic 263
 Mutualism 168, 169
 Mycelium fungi 156
 lichens 137
 mushrooms 157
 Mycorrhiza 409
 symbiosis 136
 Myelin sheath 187
 Myoelectric arms 253
 Myofibrils 184
 Myofilaments 184
 Myometrium 199
 Mythical world view 8
 Mytilus edulis 171
 Myxomycota 151
 N
 N-type semiconductors 346
 integrated circuits 350, 351
 transistors 348
 Nail bed 181
 Nail matrix 181
 Nails 181
 Nair Al Zaurak 587, 588
 Names, scientific 11, 150
 Namib Desert 385
 NAND gate 590
 Nanga Parbat 585
 Naphtha, fractional distillation 115
 Naphthalene 55
 Napier, John 559, 596
 Napier's Bones 559
 NASA, Pathfinder space probe 297
 Nasal bone 183, 201, 205, 206
 Nasal cartilage 204
 Nasal cavity human anatomy 194, 196, 204, 205
 mammals 166
 Nasal inhalers, drugs 255
 Nasal septum 204
 Nasal speculum 258
 Nash 589
 Nasomaxillary suture 206
 Nasopharynx 204
 Natal cocoons, star formation 527
 Natural cycles 172-5
 Natural drugs 254
 Natural forces 14-15
 Natural gas 52
 Natural laws 9
 Natural philosophy 14, 66
 Natural sciences 8
 Natural selection 121, 128
 Natural variation, heredity 127
 Nautilus 152
 Navel 180, 209
 Navigation 41
 Nazca plate 272, 277
 Nebulae 324, 326, 327, 409
 Neck, birds 164, 165
 Neck (human body) 176, 180
 anterior view 205
 lateral view 204
 muscles 201-5
 nape of 180
 Neck, teeth 197
 Nectar, insect-pollinated plants 146
 Nectaries, carnivorous plants 145
 Needle holders 246
 Needles, pine trees 141
 Needles, surgical 246
 Negative electric charge 40, 42
 Negative numbers 359, 360
 Nematocysts, cnidocytes 150
 Nematoda 152
 Nemertea 153
 Neodymium 74
 Neon 75
 Neon lamps 50
 Neonatal jaundice 257
 Neoteny, axolotls 161
 Nephridium, annelid worms 152
 Nephrology 581
 Nephrons 198
 Neptune 294-5, 520
 data 584
 discovery of 297
 moons 585
 rings 508, 520
 size 504
 space probes 502, 520
 Neptunium 74
 Nervous reflexes 409
 Nervous system 186-7, 409
 anesthetics 247
 annelid worms 152
 arachnids 155
 crustaceans 154
 emergency care 245
 endocrine system and 188
 head and neck 200
 insects 156
 magnetic resonance imaging (MRI) 242
 mammals 166
 microsurgery 248
 nerve endings 181
 nerve fibers 181, 187
 neuromuscular junction 184
 research 179
 teeth 197

- Nests
birds 164
crocodilians 162
spiders 155
- Networks
capacitors 345
computers 357, 354-5
fullerenes 104
- Neumann, John von
357, 396
- Neural spines, fish 158
- Neurohypophysis 188
- Neuromuscular
junction 184
- Neurons 186-7, 409
association 186, 187
motor 184, 186, 187
sensory 186, 187
- Neurosecretory cells,
hypothalamus 188
- Neutralization of acids 85
- Neutrinos, Sun 307
- Neutron stars 326, 327, 350
- Neutrons 72, 409
boron 72
isotopes 72
neutron detectors 15
nuclear fission 59
nuclear physics 58
particle physics 60
relative atomic mass
(RAM) 72
in stars 350
- Neutrophils 191
- New General Catalog,
galaxies 328
- New Guinea 382
- New moon 310
- Newton, Isaac 11, 396
calculus 359
Mathematical
Principles 15
Newton's Laws 14, 22-3
telescope 296, 297
Universal Theory of
Gravitation 297
on the universe 296
- Newton meters 9, 409
measuring force 20
measuring limiting
friction 24
measuring turning
force 21
measuring weight 18
- Newton metres 21
- Newtonian physics 14, 15
- Newtonian telescopes 298
- Newtons 377
measuring force 20
measuring weight 18
- Newtons per square
meter 21
- Newts 160, 161
great crested 161
Niacin 381
- Niagara Falls 385
- Nickel
catalysts 88
in Earth's core 270
element 68
periodic table 75
- Nickel nitrate 70
- Niger, River 285
- Nile, River 285, 383
- Nimbostratus clouds 292
- Nimbus clouds 292
- Nimrod-Lennox-King Ice
Passage 383
- Niobium 74
- Nipples 409
- North pole 180, 208
mammals 166
marsupials 166
- Nitrates
carnivorous plants 145
decomposition 173
formula 379
nitrogen cycle 172
- Nitric acid 82, 106
- Nitrites, nitrogen
cycle 172
- Nitrogen 106-7
acid rain 174
in air 70
ammonia 68, 106, 107
catalytic converters 89
chlorophyll 100
compounds 106
decomposition 154
DNA 115
melting and boiling
points 379
nitric acid 82
nitrogen cycle 172
periodic table 75, 106
preparation 106
radiocarbon dating 268
- Nitrogen dioxide
decomposition 80
oxidation number 82
preparation 82
- Nitrogen monoxide 80
- Nitrogen oxides 80, 82, 89
- Nitrous acid, nitrogen
cycle 172
- Nobel Prizes 11
- Nobelium 75
- Noble gases 409
in air 106
periodic table 74, 75
reactions with
halogens 110
- Nodes, flowering
plants 142
- Non-Euclidean geometry
358, 359, 364
- Nonflowering plants
138-41
- Nonmetals
atoms 76
carbon 104
characteristics 76
periodic table 74-5
salts 86
- Nonane, fractional
distillation 113
- NOR gate 390
- North America
data 382
formation of 273
- North American plate 272
- North Celestial Pole 300
- North Galactic Pole 329
- North Pole
ice sheet 283
magnetic pole 271
winds 291
- North Sea 382
- North seeking pole 41
- Nose
breathing 195
diagnosis 238
human anatomy 181,
203, 205
olfactory tract 207
respiratory system 194-5
- Nostrils
crocodilians 163
human anatomy 205
- NOT gate 390
- Notation, scientific 395
- Notochord 130
- Novaya Zemlya 383
- Nuchal ligament 203
- Nuclear fission see
Fission
- Nuclear fusion see Fusion
- Nuclear membrane 122
- Nuclear physics 58-9
Nuclear power stations 59
- Nuclear reactions 409
in Earth's core 270
in stars 326, 327
Sun 17, 304, 306, 307
- Nucleic acids 121
viruses 134
- Nucleoid, bacteria 134
- Nucleotides 409
RNA 125
- Nucleus (atoms) 56,
72, 409
atomic number 74
boron 72
discovery of 15
electron shells 72
particle physics 60
- Nucleus (life
sciences) 409
cells 122, 123
euglenoids 135
mushroom cells 137
prokaryotic
organisms 134
- Numbers 360-1, 376
algebra 362-3
calculators 358
computers 352
mathematics 358
- Numerator 361
- Nunki 387, 388, 389
- Nurses, operating
rooms 246
- Nutrient molecules 409
- Nutrients 409
decomposition 134
recycling 168
- Nyasa, Lake 385
- Nylon
formation of 114
polymers 114
- O**
- Oak trees 144
- Oases 280
- Ob-Irtysh, River 385
- Oberon 308
- Objective lenses,
binoculars 52
- Oblique fissure,
lungs 194
- Observation
astronomy 300-1
empiricism 9
- Obstetrics 381
- Obturator fascia 222, 225
- Obturator foramen 185
- Obturator nerve 221
- Obtuse angles 366
- Occipital bone 183, 206
- Occipital condyle 206
- Occipital lobe, brain 187,
206, 207
- Occipital nerve 202
- Occipitomastoid suture 206
- Occluded fronts 295
- Ocean-floor
spreading 267
- Oceanic crust, fold
mountains 277
- Oceans 270, 288-9
coastlines 286-7
food webs 171
formation of 268
hydrological science 266
plate tectonics 272-3
primary production 380
river deltas 285
sizes 382
tidal power 47
trenches 382
water cycle 172, 267
- Octagons, geometry 392
- Octahedrons 364, 392
- Octopus vulgaris* 153
- Octopuses 152, 153
classification 132
- Oersted, Hans Christian
15, 396
- Ohm, Georg 337, 396
- Ohms 377
electric circuits 42
resistors 340
- Ohm's Law 42, 337
- Oil
catalytic cracking 113
electricity generation 46
formation 269
fractional distillation 113
hydrocarbons 112
lubrication 25
- Oils, production
of soap 99
- Ointments 255
- Olbers, Wilhelm 332
- Olbers' Paradox 332
- Oldham, Richard Dixon
267, 396
- Olecranon 229
- Olfactory bulb 205
- Olfactory epithelium 205
- Olfactory nerve 205
- Olfactory tract 205, 207
- Oligochaeta 132
- Olympus Mons, Mars
314, 315
- Omentum
greater 216, 217, 219
lesser 217
- Ommatidia, compound
eyes 156
- Omnivorous 409
- Oncology 381
- Onions 123
- Oncophora 133
- Oncophorans,
classification 133
- Oomycota 131
- Ooze, ocean floor 288
- Open clusters, stars 324
- Open heart surgery
246, 247
- Operating theatres 246-7
- Operational amplifiers
(op-amps) 350
- Operculum
cnidocytes 150
fish 158, 159
- Ophiotrix fragilis 151
- Ophiuchus constellation
386, 388
- Ophiuroidea 133
- Ophthalmoscopes 258
- Opium 257, 254
- Opossums 167
gestation period 380
- Optic nerve
compound eyes 156
human anatomy 203,
205, 207, 251
- Optical brighteners 56
- Optical fibers
computer networks
337, 354
endoscopes 248
laser surgery 249
- Optics
binoculars 52
history 14
Newton's theories 14
telescopes 298
- Optimisticheskaya 383
- OR gate 370, 390
- Oral medicines 255
- Orangutans, gestation
period 380
- Orange light
neon lamps 50
sodium lamps 50
white light spectrum 49
- Orbital septum 200
- Orbitals 409
electrons 56, 72
hybrid 79, 104, 105
molecular 78, 79
periodic table 74
probability 368
- Orbits 409
centripetal force 28
comets 322
Earth 270, 271, 304
Jupiter 316
Mars 314
Mercury 312
Moon 311
Neptune 320
planets 29, 304-5, 308
Pluto 320, 321
Saturn 318
Uranus 319
Venus 29, 304, 313
- Orbits (skull)
birds 164
mammals 166
- Ordovician period 268
- Ores 76, 409
iron 77
- Organelles 123, 409
animal cells 122
chloroplasts 123, 148
prokaryotic
organisms 134
- Organic 409
- Organic chemistry
67, 112-15
carbon 104
- Organic molecules 409
- Organisms 409
cells 122
classification 130-3
evolution 128
microorganisms 134
- Organs 409
transplants 250-1
- Orion Arm, Milky Way
Galaxy 329
- Orion constellation 324,
386, 389
- Orion Nebula 324, 326,
329
- Orion's Belt 324,
326, 329
- Ornithoptera
alexandrae* 157
- Ornithorhynchus
anatinus* 167
- Oropharynx 204
- Orthoclase 279
- Orthopaedics 381
artificial parts 253
- Orthorhombic system,
crystals 34
- Oscillation 30-1
electromagnetic
radiation 48
wave behavior 54
- Oscillators 409
- Oscilloscopes 31, 339

- alternating current 358
 inductors 344
 tuned circuits 345
- Osculum, sponges 150
- Osmium 74
- Ossification, hand bones 229
- Osteichthyes 153, 158
- Osteopathy 381
- Osteoporosis 381
- Ostia, sponges 150
- Ostrich 165
- Othotsk, Sea of 382
- Otosopes 258
- Otters, homes 380
- Ounces 376, 377
- Output signal, amplifiers 549
- Ova see Eggs
- Ovarian ligament 199
- Ovaries 410
 annelid worms 152
 cysts 248
 endocrine system 188, 189
 fertility treatment 256
 fish 158
 flowers 145, 144
 human body 198, 224
 lizards 162
 menstrual cycle 225
 ovulation 199, 225
 seed fertilization 147
 succulent fruits 147
- Overturnd folds 277
- Oviducts, lizards 162
- Oviparous 410
 reptiles 162
- Ovotestis, gastropods 153
- Ovulation 199, 225
- Ovules
 conifers 141
 fertilization 146, 147
 flowers 145
- Ovuliferous scales 141
- Ovum see Eggs
- Owls, food chains 170
- Oxidation 67, 82-3, 410
 bleaching 111
 electrolytic cells 96
 preparation of chlorine 110
 transition metals 102
 voltaic cells 97
- Oxidation number 82, 410
- Oxides
 bases 84
 formula 379
 iron 77
 metals 76
 salts 86
 thermite reaction 90, 91
- Oxonium ions 84
- Oxygen 108, 410
 aerobic respiration 124
 in air 70, 106, 108
 carbon cycle 173
 combustion 77, 83, 108
- dehydrating agents 92
 diatomic molecules 77, 80
 discovery of 66, 67
 in Earth's crust 379
 electrolytic decomposition of water 96
 emergency care 245
 ethanol 68
 extraction of iron 77
 fatty acids 99
 formation of Earth's atmosphere 268
 free radical 410
 gills 158
 hemoglobin 114, 115
 hydrogen bonding 79
 laboratory preparation 108
 melting and boiling points 379
 mercury oxide 69
 metal oxides 76
 metals and 77
 monitoring heart rate 244
 nitrogen cycle 172
 nitrogen dioxide 80
 oxidation 82
 oxygen cycle 173
 ozone depletion reactions 111
 periodic table 75, 108
 photosynthesis 148
 reactivity 94
 rusting of iron 82
 test for 108
 therapy 244
 thermite reaction 91
 water 68, 92
- Oxytocin 188
- Oystercatchers 165
- Ozermaya 385
- Ozone layer 290
 CFCs and 110, 111
 discovery of 267
 over South Pole 374-5
 telescopes and 299
 thinning 111, 174
- P**
 P-n junctions, diodes 346
- P-orbitals 72
 covalent bonding 79
 hybrid orbitals 79, 105
 ionic bonding 78
- P-type semiconductors
 doping 346
 integrated circuits 350, 351
 transistors 348
- P waves, earthquakes 274
- Pacemakers, heart 252, 253
- Pacific Ocean
 earthquakes and volcanoes 274
 size 382
- Pacific plate 272
- Pacinian corpuscles 181
- Pain receptors 181
- Painter's palette 144
- Palaemon serratus* 171
- Palate 196, 204, 205
 cleft 263
- Palatine bone 206
- Palladium 75
- Paleontology 120
- Paleozoic era 268, 269
- Palisade mesophyll 149
- Palladium 75
- Palm, hand 180, 228
- Palmar arch 228
- Palmeate newt 160
- Pancreas
 birds 164
 endocrine system 188
 functions 189, 196, 219
 human body 216, 217
 structure 189
 transplants 251
- Pancreatic duct 196, 197, 216
- Pangaea 267, 268, 269, 272, 273
- Panthalassa 275
- Panthera* 150
- Panthera tigris* 150
- Paper
 burning 52
 filters 70, 71
 induction in 40
- Paper chromatography 70
- Papilla, flowers 145
- Papillae, tongue 205
- Parabolas 410
 algebra 363
 cones 365
- Parabolic dunes 280
- Paracelsus 66, 397
- Paraffin oil, fractional distillation 115
- Parallax shift 300
- Parallel circuits 359
 capacitors 345
 resistors 340
- Parallel postulate 359
- Parallelograms, geometry 392
- Paramecium 135
- Paramedics 244, 410
- Parasites 154, 410
 fleas 157
 fungi 156
 immune system 260
 lampreys 159
 malaria 259
 parasitism 168, 169
 tapeworms 152
 ticks 155
- Parathyroid gland 188, 189
- Parathyroid hormone 189
- Paré, Ambroise 237, 397
- Parent nucleus, nuclear fission 59
- Parental care 410
- crocodilians 162
 mammals 166
- Parietal bone 183, 206
- Parietal lobe 206, 207
- Parietal peritoneum 225, 224
- Parotid duct 196, 201
- Parotid glands 196, 200, 201, 205
- Parotid plexus 202
- Parrots 164
- Parsecs 410
- Particle accelerators 15, 60-1
- Particles 15, 60-1, 410
 atoms 56-7
 Brownian motion 16
 chaos theory 372
 colloids 70
 crystallization 16
 dissolving 16
 distillation 71
 electromagnetic radiation 48
 evaporation 16
 filtration 71
 gas molar volume 73
 gases 32, 38
 heat 90
 kinetic energy 33
 liquids 32, 36
 matter 16
 melting 33
 mixtures 70
 Newtonian physics 14
 nuclear physics 58
 quantum theory 62
 solids 32
 solutions 70
 supercooled liquid 52
 suspensions 70
 temperature 32
- Pascal, Blaise 337, 358, 397
- Pascals 377
- Passive immunization 261
- Patau's syndrome 263
- Patella
 blood vessels 230
 human skeleton 182, 250, 252
 joint 185
 mammals 166
 spiders 155
- Patella vulgata 171
- Patellar ligament 250, 252
- Paternity testing 263
- Pathfinder space probe 297
- Pathology 381
- Patients
 emergency care 244-5
 operating theatres 246-7
- Patina, bronze 105
- Patos-Maribondo Falls 383
- Pauling, Linus Carl 67, 397
- Paulo Afonso Falls 383
- Paupropoda 152
- Pavo constellation 388
- PCBs see Printed circuit boards
- Peacock constellation 388
- Peacock worms 152
- Peanut worms, classification 133
- Pebbles, beaches 287
- Pecks 376
- Pecten 153
- Pectoral fins, fish 158, 159
- Pectoral girdle
 human body 182, 227
 tortoises 162
- Pectoral muscles, birds 165
- Pedals 27
- Pediatrics 381
- Pedicels, flowers 143, 144, 145
- Pedicels, spiders 155
- Pedicle of vertebral arch 211
- Pedipalps 410
 arachnids 155
 chelicerates 154
 spiders 155
- Peduncles, flowers 144
- Pegasus constellation 386, 387, 388
- Pellicle, euglenoids 135
- Pelvic cavity 222
- Pelvic diaphragm (floor) 222
- Pelvic fins, fish 158, 159
- Pelvic girdle
 human skeleton 182, 183, 222
 tortoises 162
- Pelvic region 180, 410
 female 224-5
 male 222-5
- Pelvis 410
 birds 164
 bone marrow 250
 human body 183, 222
 mammals 166
 Pelvis minor 220
- Pencil "lead" 104
- Pendulums 30
 clocks 14
- Penguins 165
 speed 380
- Penicillin, discovery of 257
- Penicillium, classification 131
- Penile urethra 223
- Peninsular Valdez 382
- Penis 181, 198, 199, 222, 225
- Penstock 46
- Pentadactyl limbs 129
- Pentagons, geometry 392
- Pentaradial symmetry 410
 echinoderms 150
- Penumbra 306, 310
- Penzias, Arno Allan 297, 397
- Peppered moth, natural selection 128
- Percentages 360, 361
- Perching birds 164
- Peregrine falcons, energy requirements 380
- Perennial flowering plants 142
- Pericardium 212, 213, 214, 215
- Pericarp, succulent fruits 147
- Perihelion 308, 410
- Perimetrium 199
- Perineal blood vessels 222
- Perineal nerves 222
- Perineum
 female 225
 male 222
- Periodic table 67, 74-5
 alkali metals 98
 alkaline earth metals 100
 carbon 104
 halogens 110
 nitrogen 106
 oxygen 108
 phosphorus 106
 silicon 104
 sulfur 108
 tin 104
 transition metals 102
- Periodontal ligament 197
- Periods (menstruation) 225
- Periosteum 182, 184
- Peripheral nervous system 186-7
- Perirenal fat 220
- Peristalsis 197
- Peritoneum 216
- Permafrost, on Mars 315
- Permanent magnets 410
- loudspeakers 31
- Permeability 410
- Permian period 269
- Peroneal nerve 231, 233
- Perseid meteor shower 323
- Perseus Arm, Milky Way Galaxy 329
- Perseus constellation 387, 388
- Personal computers (PCs) 352-3
- Perspective 358
- Perspex 24
- Pesticides 174
- PET see Positron emission tomography
- Petals 142, 143, 144, 147
- Petermanns Glacier 383
- Petioles
 cycads 140
 flowering plants 142, 144, 145
 ginkgo 140
 herbaceous flowering

- plants 142
 Petiolules 144
 pF see Picofarads
 pH scale 84, 410
 acid rain 174
 discovery of 67
 Phaeophyta 130
 Phaet 389
 Phagocytes 195, 260
 Phalanges (phalanx)
 181, 182, 228, 232
 growth of 229
 Pharmacology 254-5,
 381, 410
 Pharyngeal tonsil 204
 Pharynx
 anemones 150
 annelid worms 152
 fish 158
 human anatomy 194,
 196, 200, 205
 insects 156
 Phase (astronomy) 410
 Mercury 312
 Moon 310
 Venus 312
 Phase (electronics) 410
 Phekda 387
 Phenotypes, heredity
 126, 127
 Philippine plate 272
 Philippine Trench 382
 Philosophers' stone 66
 Philosophy 14
 Phlegm, "humors" 236
 Phloem, plant-transport
 systems 148, 149
 Phlogiston theory 66, 67
 Phobos 314
Phoca vitulina 171
 Phoenix constellation
 387, 388
 Phoronida 133
 Phoronids,
 classification 133
 Phosphates
 decomposition 173
 DNA 115
 Phospholipids 124
 Phosphor
 fluorescent lamps 50
 television screens 57
 Phosphorescence 410
 cathode-ray tubes 57
 Phosphorus 106
 activation energy 90
 allotropes 106
 doping semiconductors
 346
 on Jupiter 317
 periodic table 75, 106
 Photo masks, integrated
 circuit manufacture 351
 Photocatalysis 88
 Photoelastic stress
 testing 55
 Photography
 catalysts 88
 sodium thiosulphate
 108, 109
 X rays 49
 Photons 410
 electromagnetic
 radiation 48
 lasers 56
 luminescence 56
 particle accelerators 60
 particle physics 60
 quantum theory 62
 Photosphere, Sun 307
 Photosynthesis 148, 410
 algae 135, 137
 carbon cycle 175
 catalysts 88
 chlorophyll 100
 chloroplasts 123
 cyanobacteria 134
 euglenoids 135
 food webs 171
 lettuce slugs 153
 oxygen cycle 175
 seaweeds 138
 sunlight 306
 Phototherapy 257
 Photovoltaic cells 17
 Phrenic nerve 213, 214
 Phyla, classification 133
 Phylloides, carnivorous
 plants 145
 Phylogeny 132
 Phylum 410
 classification 130
 Physical sciences 8
 Physical weathering 280
 Physicians, diagnosis 238
 Physics 6, 12-63
 astrophysics 296
 circular motion 28-9
 color 50-1
 electric circuits 42-3
 electricity and
 magnetism 40-1
 electromagnetic
 radiation 48-9
 electromagnetism 44-5
 electrons 56-7
 forces 20-5
 formulas 378
 friction 24-5
 gases 38-9
 generating electricity 46-7
 heat and
 temperature 32-3
 history 14-15
 liquids 36-7
 matter and energy 16-17
 measurement and
 experiment 18-19
 medical physics 237
 modern physics 15, 62-3
 Newtonian physics 14, 15
 nuclear physics 58-9
 particle physics 60-1
 reflection and
 refraction 52-3
 simple machines 26-7
 solids 34-5
 wave behavior 54-5
 waves and
 oscillations 30-1
 Physiological 410
 Physiology 178, 179
 Physiotherapy 381
 Phytol 100
 Phytoplankton 410
 diatoms 135
 food webs 171
 Pi, circles 364
 Pi mesons 60
 Pia mater 186
 Picofarads (pF) 342
 Picometers 98
 Picos de Vallibierna 277
 Pie charts 368, 369
 Pigments
 bleaching 111
 chlorophyll 148
 color 50
 paper chromatography 70
 pH scale 84
 subtractive process 51
 transition metals 102
 Pigs, heart-valve
 transplants 251
 Pileus, gilled
 mushrooms 137
 Pili, bacterium 134
 Pillow lava 288
 Pills, drugs 255
 Pinacocytes, sponges 150
 Pine trees 140, 141
 Pineal gland 187,
 188, 189
 Pinna
 human anatomy 205
 mammals 166
 Pinnae, ferns 139
 Pinnate leaves 144
 Pinnipedia 167
 Pinnules, ferns 139
 Pinocytic vesicles 122
 Pints 376, 377
Pinus sylvestris 141
Pioneer 10 space
 probe 302
Pioneer 11 space
 probe 302
 Pisces Austrinus
 constellation 388
 Pisces constellation
 386, 388
 Pistons
 air pumps 66
 motorcycle brakes 25
 Pith
 herbaceous shoots 149
 woody flowering
 plants 142
 Pituitary gland 187, 207
 functions 188, 189
 structure 188
 Pivot, turning forces 21
 Pivot joints 185
 Place-value systems,
 numbers 360
 Placenta 410
 chorionic villus
 sampling 256
 human body 199
 Placental mammals
 166, 167
 Plains 284, 285
 Planck, Max Karl Ernst
 15, 397
 Plane, inclined 26
 Plane angles, SI units 377
 Plane shapes,
 geometry 392
 Plane wave 410
 wave behaviour 54
 Planet X 320
 Planetary nebulae 326, 327
 Planetismals 268
 Planets 308-9
 asteroid belt 323
 centripetal force 28
 data 384
 gravity 29
 history of astronomy 296-7
 infrared astronomy 299
 Jupiter 316-17
 Mars 314-15
 Mercury 312
 Neptune 320
 orbits 29, 304-5, 308
 Pluto 320-1
 rings 309
 Saturn 318
 solar system 304-5
 space probes 297, 302-
 5, 308
 Uranus 318-19
 Venus 312-13
 Plankton
 food webs 171
 phytoplankton 135
 Plantae 130, 131
 Plantar aponeurosis 232
 Plants
 asexual reproduction 126
 carbon cycle 173
 cells 122, 123
 chlorophyll 100
 classification 120, 130-1
 drugs 254
 ecology 121
 evolution 128, 268, 269
 flowering 142-7
 food chains 170
 internal anatomy 149
 natural cycles 172-3
 nitrogen cycle 172
 nonflowering 138-41
 oxygen cycle 173
 parasitism 169
 photosynthesis 88, 100,
 121, 123, 148, 306
 transport systems 148, 149
 weathering and
 erosion 280
 Plasma (blood) 191
 antibodies 250
 Plasma membrane
 animal cells 122
 bacteria 134
 plant cells 123
 Plasmid, genetic
 engineering 262
 Plasmodesma 123
 Plasmodial slime mold,
 classification 131
 Plaster of Paris,
 formula 379
 Plastic sulfur 109
 Plastics 114
 artificial body parts
 252, 253
 discovery of 67
 structures 379
 thermoplastics 114
 thermosetting 114
 Plastron, tortoises 162
 Plate tectonics 267, 272-3
 earthquakes and
 volcanoes 274-5
 faults and folds 276-7
 on Mars 315
 metamorphic rocks 278
 mid-oceanic ridges 288
 on Miranda 319
 mountain building 277
 ocean currents 269
 Platelets 191
 Platinum
 catalytic converters 89
 discovery of 379
 flame tests 116
 periodic table 75
 reactivity 94
 reactivity with dilute
 acids 95
 transition metal 102
 Platonic solids,
 geometry 364
 Platyhelminthes 132, 152
 Platypus, duck-billed 167
 Playas 281
 Pleiades 324, 328,
 387, 388
 Pleura 205, 212, 214, 215
 Pliohippus 129
 Plugs, volcanoes 275
 Plumules
 conifers 141
 fava beans 147
 Plunge pools 284, 285
 Plutinos 320, 321
 Pluto 304, 320-1
 data 384
 discovery of 297
 moons 385
 orbit 305
 Plutonium 74
 Pneumonia 259, 381
 Poincaré, Jules Henri
 359, 397
 Point of suspension 21
 Poisons
 cnidocytes 150
 salamanders 161
 scorpions 155
 snakes 163
 spiders 155
 Polar-front jet
 stream 291
 Polar-night jet
 stream 291
 Polar nucleus 410
 seed fertilization 147
 Polaris (Pole Star) 328, 387
 Polarized light 54, 55
 Pole Star (Polaris) 328, 387
 Poles
 celestial 300
 Earth 270, 271
 magnets 41
 Poliomyelitis vaccine
 237, 261
 Pollachius pollachius 171
 Pollack 171
 Pollen 410
 conifers 141
 gymnosperms 140
 structure 146
 see also Pollination
 Pollen tubes
 conifers 141
 fertilization 147
 Pollex 228
 Pollination 410
 conifers 141
 flowering plants 142,
 144, 146, 147
 insect-pollinated
 plants 146
 wind-pollinated
 plants 146
 Pollution 174
 acid rain 174
 catalytic converters 88, 89
 electricity generation 46
 Pollux 386, 389
 Polonium 75
 Polychaeta 132
 Polychaetes 152
 Poly(chloroethene)
 (PVC) 114, 115
 structure 379
 Polygons 411
 geometry 364
 Polyhedrons
 (polyhedra) 411
 geometry 364
 Polymerization 114, 115
 Polymers 114, 411
 artificial body parts 252
 Polynomials, algebra
 362, 363
 Polyplacophora 132
 Polyps 150
 Polysaccharides 114
 Polystyrene, structure 379
 Polythene 114
 static electricity 40
 structure 379
 Polytrichum commune 138
 Polyvinylchloride (PVC),
 structure 379

- Ponds, pollution 174
 Pondweeds 144
 Pons 187, 207
 Pools, plunge 284, 285
 Poor metals, periodic table 74-5
 Pope, Alexander 296
 Popliteal fossa 180
 Popliteal lymph nodes 192
 Population growth, humans 174
 Populations, species 168
 Pores
 fungi 136
 sponges 150
 Porifera 152
 Porocytes, sponges 150
 Porphyrin ring, chlorophyll 100
 Porrima 589
 Ports, computers 355
 Positive electric charge 40, 42
 Positive ions 41
 Positive numbers 560
 Positron emission tomography (PET) 242, 245
 Positrons 411
 particle accelerators 60
 Post-central gyrus 206
 Posterior crural intermuscular septum 255
 Posterior lobe, pituitary gland 188
 Posterior tubercle, vertebrae 211
 Postulates, mathematics 558, 559
 Potassium
 atomic diameter 98
 discovery of 67
 in Earth's crust 379
 flame tests 116
 formula 379
 ionic diameter 98
 periodic table 74, 98
 reactivity 94
 sea water 288
 Potassium chromate 105
 Potassium dichromate 105
 Potassium iodide 80
 Potassium nitrate 80
 Potassium
 permanganate crystallization 16
 dissolving 16
 Potatoes, digestion of starch 89
 Potential energy 16, 17, 411
 cars 17
 hydroelectricity 46
 Potentiometers 340, 341
 Potholes 281
 Pouches, marsupials 167
 Pounds 376, 377
 Powdered laundry detergent 89
 Power
 formula 378
 SI units 577
 see also Energy
 Power stations
 generators 46
 history 536
 hydroelectricity 46
 nuclear power 58, 59
 Power transistors 549
 Powers of ten 577
 Praseoep 386
 Praseodymium 74
 Prawns 171
 Precambrian era 268
 Precambrian gyros 206
 Precession 29
 Precipitates 411
 chemical analysis 116
 chemical reactions 8, 80
 Precipitation, weather 292
 Predators 411
 birds of prey 165
 chaos theory 372
 ecosystems 168
 food chains 170
 sharks 159
 Pregnancy 225, 256-7
 hormones 189
 ultrasound scanning 240
 Prehensile 411
 Premature babies 256, 257
 Premises, logic 370, 371
 Premolars
 carnivores 166
 herbivores 166
 human 196
 Prenatal tests 256
 Prepuce
 clitoris 225
 penis 225
 Pressure 21, 411
 blood pressure 259
 Boyle's Law 58
 Charles Law 59
 formula 378
 gases 58-9
 liquids 36, 37
 SI units 577
 standard temperature and pressure (STP) 75
 Pressure Law 58, 59
 formula 378
 Pressure receptors 181
 Prevailing winds 291
 Priestley, Joseph 66, 67, 397
 Primary colors 411
 additive process 51
 vision 50
 Primary plexus, pituitary gland 188
 Primary response packs, paramedics 244
 Primates 167
 evolution 269
 Principle of Conservation of Energy 16, 411
 Principle of Superposition 54, 411
 Printed circuit boards (PCBs) 537, 538
 Printers, computers 553
 Prion proteins 258, 259
 Prisms
 binoculars 52
 geometry 392
 white light spectrum 49
 Prizes 11
 Probability 558, 568-9
 Procyon 386, 389
 Product, chemical reactions 80, 411
 Progesterone 189
 Proglottids, tapeworms 152
 Prokaryotic cells 122, 154
 Proliferative phase, menstrual cycle 225
 Promethium 74
 Prominences, Sun 507
 Proofs, logic 371
 Propane 112, 115
 Propene 112
 Properties, chemical reactions 68, 69, 80
 Prophase, mitosis 126
 Propyne 112
 Prostate gland 198, 199, 225
 Prostatic urethra 225
 Prostheses 253
 Protactinium 74
 Proteins 411
 enzymes 88, 124
 genetic mutations 265
 hemoglobin 115
 prions 258, 259
 sequence 411
 structure 411
 synthesis 124
 viruses 134
 Protista 150, 151
 Protists 134
 cells 122
 classification 150, 151
 structure 135
 Proton-proton chain, Sun 507
 Proton synchrotron (PS) ring 61
 Protons 72, 411
 acids 84
 atomic number 72, 74
 bases 84
 boron 72
 cosmic rays 58
 electromagnetic radiation 49
 isotopes 72
 neutron detectors 15
 nuclear physics 58
 particle accelerators 60, 61
 particle physics 60
 positive electric charge 40
 relative atomic mass (RAM) 72
 in stars 350
 Protoplanets 504
 Protostars 526, 527
 Protozoans 134
 amoebas 135
 infections 258, 259
 Protractor muscle, arthropods 154
 Protusible 411
 tube feet 150
 Proust, Joseph Louis 67, 597
 Proust's Law 67
 Proximal convoluted tubule 198
 Proximal phalanx 228, 232
 Pseudohearts, annelid worms 152
 Pseudopodia
 amoebae 155
 phagocytes 260
 Psilophyta 151
 Psoriasis 581
 Psychiatry 581
 Pterophyta 151, 158
 Pteropus 167
 PTFE, structure 379
 Ptolemy 296, 297, 397
 Almagest 296
 Ptolomaeus crater, Moon 511
 Ptyalin 88, 89
 Pubic symphysis 185
 Pubis 182, 183
 Public health 236
 Public understanding of science 11
 Puerto Rico Trench 382
 Puffballs 136
 Classification 151
 Pull 20
 Pulleys 26, 27
 Pulmonary capillaries 191
 Pulmonary circulation 190, 191
 Pulmonary semilunar valve 191
 Pulp cavity, teeth 197
 Pulsars 530
 discovery of 297
 Pulse
 measuring blood pressure 259
 medical diagnosis 258
 Pumps
 drugs 255
 nuclear power stations 59
 Pupae 411
 metamorphosis 156, 157
 Pupils, eyes 205
 Puppis constellation 386, 389
 Purace 383
 Pure mathematics 358
 Push 12
 PVC 114, 115
 structure 379
 Pycnogonida 135
 Pygostyles, birds 164
 Pylons, electricity 59
 Pyloric cecum, echinoderms 151
 Pyloric sphincter 197
 Pylorus 197
 Pyramids, geometry 364, 592
 Pyrenees 277
 Pyrenoid, euglenoids 155
 Pyridoxine 581
 Pyrites, iron 68
 Pyrrophyta 151
 Pyruvic acid 124, 411
 Pythagoras 397
 Pythagorean theorem 358, 359, 366, 367
 Pythons 165
 Pyxis constellation 586
- ## QR
- Quadrant lobe, liver 217
 Quadratic curves 365
 Quadrats 8, 175
 Quadrilaterals, geometry 364
 Quadrillion 377
 Quadruple pulleys 27
 Quantum theory 9, 15, 62
 Quarantid meteor shower 325
 Quarks 60, 411
 discovery of 15
 Quarts 376
 Quartz
 crystals 68
 formation 279
 glass 105
 silicon 104, 105
 Quasars 528, 535, 411
 Big Bang 532
 black holes 531
 Döppler shift 501, 535
 Quaternary period 269
 Queen Alexandra's birdwing butterfly 157
 Queens, tree wasps 157
 Quicklime 107
 Quinine 254
 Quintillion 377
 R strategy, reproduction 169
 RA see Right ascension
 Rabbits 166
 homes 380
 Rachis
 ferns 159
 leaves 144
 Radar 411
 mapping 315
 space probes 512, 513
 telescopes 299
 Radial nerve 186, 226, 227, 229
 Radial symmetry 411
 cnidarians 150
 Radian, SI units 377
 Radiated tortoise 162
 Radiation 411
 cosmic background radiation (CBR) 352, 353
 electromagnetic 17, 48-9
 heat transfer 32
 ozone layer 110, 111
 Sun 507
 X-ray imaging 240
 Radiative zone, Sun 507
 Radicals 411
 flame tests 116
 formula 379
 salts 86, 87
 Radicles, seeds 147
 Radio astronomy 297
 cosmic background radiation (CBR) 352
 space probes 502
 telescopes 299
 Radio waves 48, 411
 computer networks 554
 discovery of 15, 356
 electromagnetic spectrum 299
 magnetic resonance imaging (MRI) 242
 pulsars 350
 RF chokes 345
 tuned circuits 545
 variable capacitors 545
 Radioactivity 411
 analyzing 58
 geothermal power 47
 nuclear physics 58
 radionuclide scanning 242, 245
 Radiocarbon dating 268
 Radioisotopes, positron emission tomography (PET) 245
 Radiology 381
 Radionuclide scanning 242, 245
 Radiotherapy 381
 Radium 74, 100
 Radius
 circles 362, 364
 spheres 365
 Radius bone 411
 birds 164
 human skeleton 182, 226, 228, 229
 joint 183
 mammals 166
 Radon 75
 Radula, gastropods 152, 153
 Rails 34
 Rain 292
 acid rain 174
 hurricanes 293

- rainfall patterns 411
rainwater 86, 87
rivers 284
storm hydrographs 284
water cycle 172, 267
- Rainforests
life zones 168
primary production 380
- Raja clavata* 159
- RAM see Random access memory; Relative atomic mass
- Ram constellation 386
- Ramenta, ferns 159
- Random access memory (RAM), computers 352, 353, 412
- Rapids, rivers 284
- Rare earth metals, periodic table 74-5
- Rarefaction 412
sound waves 51
springs 50
- Ras Algethi 588
- Ras Alhague 387, 588
- Rat snake 165
- Rate of reaction 412
- Ratios
common fractions 361
golden ratio 561
mathematics 358
trigonometry 366-7
- Ratites 165
- Ray craters 308
- Rays (fish) 159
- R-C circuits 542
- Reactants 80, 412
conservation of mass 81
surface area 81
- Reaction 20, 412
Newton's Laws 22
see also Chemical reactions
- Reactivity 412
activity series 94-5
halogens 110
metals 76
- Reactors 59
- Read-only memory (ROM), computers 352, 353, 412
- Receptacles, flowers 145
- Receptor sites 412
viruses 258
- Receptors 187
cold 181
heat 181
pain 181
pressure 181
touch 181
- Recessive alleles 126, 127
- Recognition cells, immune system 260
- Recovery Glacier 383
- Rectangles
area and volume 395
geometry 392
- golden rectangle 361
- Rectification, diodes 346
- Rectifiers 346, 347
- Rectouterine pouch 224
- Rectovesical pouch 223
- Rectum
amphibians 160
birds 164
functions 197
human body 196, 217, 218, 219, 220, 221, 222, 225, 224
insects 156
lizards 162
suppositories 255
- Rectus sheath 208, 209
- Recumbent folds 277
- Recurvirostra avosetta* 165
- Recycling nutrients 168
- Red algae, classification 130
- Red blood cells
blood transfusions 251
discovery of 179
functions 191
hemoglobin 114
malaria 259
manufacture 182
stem cells 250
- Red dwarf stars 325
- Red giant stars 325, 327
- Red lead 81
- Red light
additive process 51
color vision 50
constructive interference 55
photons 48
subtractive process 51
white light spectrum 49
- Red phosphorus 106
- Red pigments, paper chromatography 70
- Red pulp, spleen 195
- Red Sea 275, 291, 582
- Red seaweeds 158
- Redox reactions 67, 82-5, 412
combustion 108
electrolytic cells 96
extraction of metals 77
reactivity 94
- Redshift 301, 412
quasars 353
- Reduction 82-5, 412
- Redwoods 140
- Reef shark, black tip 159
- Reefs, coral 289
- Refineries, oil 115
- Reflection
color 50
light 52-3
telescopes 298
total internal reflection 52
- Reflection nebulae 326
- Reflex angles 366
- Reflexes, medical
- diagnosis 258
- Refraction 412
telescopes 298
- Regoliths 310
- Regular polygons 364
- Regular polyhedra 364
- Regulus 386, 389
- Relative atomic mass (RAM) 72, 412
copper 75
iodine 75
periodic table 75
- Relative molecular mass (RMM) 72, 412
- Relativity 62, 297
Einstein's theories 15
General Theory of 62, 351
non-Euclidean geometry 364
Special Theory of 62, 65
- Relays, solenoids 344
- Remote controllers, infrared LEDs 347
- Renaissance 9
anatomical research 178-9
earth sciences 266
life sciences 120
medical science 236
physics 14
- Renal pelvis 198
- Reproduction 126-7
amphibians 160
conifers 141
earthworms 152
flowering plants 142, 146-7
fungi 156
gymnosperms 140
human body 198-9
liverworts 158
lizards 162
mammals 166
nonflowering plants 158
seaweeds 158
slime molds 155
snakes 165
strategies 169
- Reproductive system 198-9
female pelvic region 224-5
male pelvic region 222-5
- Reptiles 162-3
classification 133
endangered species 175
evolution 269
- Reptilia 133
- Research, costs 10-11
- Reseau Jean Bernard 385
- Reserves, wildlife 175
- Resistance, to antibiotics 258
- Resistance (electrical) 412
capacitors 342
formula 378
multimeters 339
- Resistant 412
- Resistor-capacitor circuits (R-C circuits) 342
- Resistors 340-1, 412
colour codes 391
electronic circuits 338
integrated circuits 350
transistors 348
values 391
- Resonant frequency, tuned circuits 345
- Respiration 412
carbon cycle 173
energy yield 124
fish 158
human body 194-5
oxygen cycle 173
and protein synthesis 124
- Respiratory bronchioles 195
- Restriction enzymes, genetic engineering 262
- Resultant 412
- Reticulum constellation 388
- Retina 205
ophthalmoscopic view 258
- Retractor muscles
anemones 150
arthropods 154
- Retractors, surgical 247
- Retrograde motion, Martian orbit 314
- Retroviruses 258, 412
- Reversible reactions
80, 412
ammonia production 107
chromate ions 103
- RF chokes 345
- Rhaddomes, compound eyes 156
- Rhea 165
Rhea americana 165
- Rhenium 74
- Rhesus monkey 166
- Rheumatoid arthritis 260
- Rhizine, lichens 137
- Rhizomes
ferns 139
flowering plants 145
horsetails 159
- Rhodium
catalytic converters 89
periodic table 74
- Rhodophyta 130
- Rhombic sulphur 108, 109
- Rhombus, geometry 392
- Rib spreaders 247
- Ribbon Falls 385
- Ribbon worms, classification 133
- Ribcage 209
exploded view 215
- Riboflavin 381
- Ribosomes 412
animal cells 122
bacteria 134
- protein synthesis 125
267, 278-9
strata 276
- Ribs
birds 164
breathing 195, 208
fish 158
human skeleton 182, 209, 212, 214, 215, 216, 220
mammals 166
tortoises 162
- Richter, Charles Francis 267, 397
- Richter scale, earthquakes 267, 385
- Rifles 285
- Rift valleys 276
- Rigel 324
magnitude 301
star maps 386, 389
- Right-angled triangles 392
- Right angles 566
- Right ascension (RA), astronomy 300
- Rills 284, 412
- Ring finger 228
- "Ring of fire" 274
- Rings
planets 308, 309, 318-19
sulphur 108, 109
- River Eridanus constellation 388
- River turtles 162
- Rivers 284-5
coastlines 286
deltas 279, 284, 285
hydrological science 266
longest 383
pollution 174
rock cycle 278-9
water cycle 172, 267
- RMM see Relative molecular mass
- RNA 412
protein synthesis 124
transcription 125
viruses 134, 258
- Robins, energy requirements 580
- Rockies 276
- Rocks 278-9
carbonate 87
evolution of the Earth 268
faults and folds 276-7
fossils 269
geological science 266
geothermal power 47
historical theories 266-7
igneous 266-7, 278-9
on Mars 303
metamorphic 269, 278-9
on Moon 310
planetary rings 308, 309
plate tectonics 272-3
quartz 104, 105
rock cycle 278
sedimentary 266,
- Rocky landscapes 280-1
- Rod, unit of measurement 376
- Rodents, food chains 170
- Rollers
ball bearings 25
reducing friction 24, 25
- ROM see Read-only memory
- Roman Catholic Church 14
- Roman Empire
earth sciences 266
medicine 236
- Roman numerals 360, 376
- Rongeurs 247
- Röntgen, Wilhelm Konrad von 15, 397
- Root succulents 145
- Roots
aerial 145
ferns 139
flowering plants 142, 145
internal anatomy 149
root cap 149
root hairs 149
root tip 149
weathering and erosion 280
- Roots, teeth 197
- Rossby, Carl-Gustaf 291
- Rossby waves 291
- Rotifera 133
- Rotiferans, classification 133
- Rotors
electric motors 45
generators 46
- Round ligament 217, 224
- Roundworms, classification 132
- Rubber 35
- Rubbing alcohol
formula 379
- Rubella vaccine 261
- Rubidium
atomic diameter 98
ionic diameter 98
periodic table 74, 98
- Rubus fruticosus* 147
- Ruby lasers 56
- Rudimentary transverse process 211
- Rugae
bladder 198
stomach 197, 219
- Ruiz 385
- Runners, herbaceous
flowering plants 142
- Rust 82
formula 379
- Rusts (fungi), classification 131
- Ruthenium 74
- Rutherford, Ernest 15, 379, 397
- Rutherfordium 379

- S**
- S-orbitals 72
- covalent bonding 79
- hybrid orbitals 79, 105
- ionic bonding 78
- S waves, earthquakes 274
- Sabella 152
- Sabik 388
- Saccharides 114
- Sacral canal 223, 224
- Sacral foramen 183
- Sacral nerves 186
- Sacral plexus 186
- Sacral promontory 185, 211
- Sacral vertebrae 211
- Sacroiliac joint 182
- Sacrolemma 184
- Sacroteruberous ligament 222, 225
- Sacrum 182, 183
- female pelvic region 224
- male pelvic region 222, 225
- mammals 166
- vertebrae 211
- Saddle joints 185
- Sagitta constellation 388
- Sagittal suture 206
- Sagittarius Arm, Milky Way Galaxy 529
- Sagittarius constellation 387, 388, 389
- Sago palm 140
- Sahara Desert 385
- Sail constellation 388
- Saiph 324, 386
- Salamanders 160
- European fire 161
- Salamandra
- salamandra 161
- Saliva 196, 412
- enzymes 88, 89
- Salivary glands
- human body 189, 196, 201, 205
- insects 156
- Salk, Jonas 237, 397
- Salmon, speed 380
- Salt (common) 86, 98
- erosion 280
- formation of 76
- formula 379
- hydrogen chloride gas 85
- ionic bonding 78
- production of soap 99
- sea water 288
- Saltation, rivers 285
- Salts 86-7, 412
- acid salts 84, 87
- ammonium ions 106
- hard water 100
- production of soap 99
- reactivity 94
- Salvarsan 237
- Samarium 74
- Sampling, computer networks 354
- San Andreas Fault 276
- Sand
- dunes 279, 280
- erosion 280
- glass 105
- mortar 101
- quartz 104
- in rivers 285
- sandy shores 286
- spits 286
- Sand dollars, classification 133
- Sandpaper 24
- Sandstone 280
- Sangay 385
- Sankey diagrams 17, 412
- Sap, plant cells 125
- Saphenous nerve 186
- Saprosbes 154, 156
- Sarcostigophora 151
- Satellites, artificial 290, 308
- Satellites, natural see Moons
- Saturn 318
- data 384
- moons 385
- rings 308, 318
- size 304
- space probes 302, 318
- Saussure, Horace
- Bénédict de 267, 397
- Sauveur, Joseph 15
- Savannah
- life zones 168
- primary production 380
- Saws, bone 246
- Scale, calcium salts 100
- Scale leaves 145
- Scalene triangles 392
- Scales 412
- crocodilians 163
- fish 158, 159
- Scales, weighing with 18
- Scales constellation 388
- Scallops 153
- classification 132
- Scalpels 246
- Scandium 74
- Scanning
- medical diagnosis 240-1
- pregnancy 256
- Scaphopoda 132
- Scapula (shoulder blade)
- human skeleton 180, 182, 226
- joint 185
- mammals 166
- pectoral girdle 227
- spine of 210
- Scarpa, Antonio 179
- Scarps 412
- rift valleys 276
- Scatter diagrams 368, 369
- Scheat 387, 388
- Schedar 387
- Scheele, Carl Wilhelm 67, 379, 397
- Schrödinger, Erwin 62
- Schrödinger's cat
- thought experiment 62
- Schwann cells 187
- Sciatic nerve 186, 231
- Science
- history 8-9
- the practice of
- science 10-11
- scientific laws 9
- and technology 8
- what is science 8-9
- Scientific Revolution 8-9
- Scientists 10, 11
- Scissors, surgical 246, 248
- Sclera 203, 205
- Scolex, tapeworms 152
- Scomber scombrus* 159
- Scorpion constellation 388
- Scorpions 154
- classification 133
- internal features 155
- Scorpius constellation 387, 388
- Scots pine 141
- Scrapyard
- electromagnets 45
- Scree slopes 280, 281
- Screening, pregnancy 256
- Screens
- cathode-ray tubes 57
- computers 352, 355
- projecting images onto 55
- television 57
- Screws 26
- Scrotal septum 225
- Scrotum 181, 199, 222, 223
- Scrubland, life zones 168
- Sculptor constellation 387, 388
- Scutes, tortoises 162
- Scyphozoa 132
- Sea anemones 169
- classification 132
- Mediterranean 150
- Sea caves 286, 287
- Sea cucumbers 151
- classification 133
- Sea-floor spreading 267
- Sea Goat constellation 388
- Sea lilies, classification 133
- Sea mammals 167
- Sea nettle jellyfish 150
- Sea slugs 155
- Sea spiders,
- classification 133
- Sea squirts,
- classification 133
- Sea urchins 151
- classification 133
- food webs 171
- Sea water 70
- mineral content 288
- Seals 166, 167
- food webs 171
- Seamounts 288, 289
- Seas see Oceans
- Seasons
- Earth's axis 271
- on Mars 314
- Seaweeds
- classification 138
- food chains 171
- food webs 171
- green seaweeds 135
- Sebaceous glands 181
- Second World War,
- computers 337
- Secondary colors 51
- Secondary plexus,
- pituitary gland 188
- Secondary sexual characteristics 412
- Seconds, SI units 18, 377
- Secretory cells, pituitary gland 188
- Secretory phase,
- menstrual cycle 225
- Secretory vesicles 122
- Sedimentary rocks 266, 267
- formation 278-9
- Sediments 412
- coastlines 286
- deltas 285
- fossil remains 268, 269
- glacial deposition 285
- moraine 282
- ocean deposits 288
- rivers 285
- waves 287
- Seed leaves 147
- Seeds 412
- conifers 141
- fertilization 147
- flowering plants 142, 146-7
- food chains 170
- germination 146, 147
- gymnosperms 140
- nonflowering plants 138
- succulent fruits 147
- Segmental bronchus 215
- Segmented worms,
- classification 132
- Segrà, Emilio Gino 67, 397
- Seif dunes 280
- Seismic 413
- Seismic waves 274
- Seismographs 266, 274
- Seismology 266
- Selenium 75
- Self inductance,
- inductors 344
- Self-similarity, fractals 372, 373
- Semen 198, 199
- DNA fingerprinting 263
- Semicircular canals,
- ears 179, 205
- Semiconductors 346, 413
- computers 337
- electronic circuits 338
- history 336
- integrated circuits 350
- LEDs (light-emitting diodes) 50
- Elwood 357, 397
- solar cells 46, 47
- thermistors 341
- transistors 348
- Semilunar fold 219
- Semilunar valve 191
- Semimetals 413
- periodic table 74-5
- Seminal vesicles 199, 223
- Seminiferous tubules 222
- Sense organs 413
- mammals 166
- smell 162, 205
- taste 162, 205
- touch 181, 187
- see also Ears; Eyes
- Sensory neurons 186, 187
- Sensory receptors 187, 413
- Sepals 142, 143, 147
- Septa, annelid worms 152
- Septal cartilage, nose 203
- September equinox 271
- Septum
- anemones 150
- heart 191
- Septum pellucidum 187
- Series circuits 339
- capacitors 343
- resistors 340
- Serotonin 261
- Serpens Caput constellation 389
- Serpens Cauda constellation 388
- Serpens constellation 386, 388
- Serpent constellation 386, 388
- Serpent Holder constellation 386
- Serum, immunization 261
- Servers, Internet 355
- Sessile 413
- sponges 150
- Seta, mosses 138
- Sets 358, 359, 370-1
- Seven Sisters 324, 328
- Sex cells 126
- fertilization 127
- human body 198, 199
- meiosis 127
- nonflowering plants 138
- Sex chromosomes,
- genetic mutations 263
- Sex hormones 188
- Sextans constellation 386, 388, 389
- Sextant constellation 386, 388
- Sexual intercourse 198, 199
- Sexual reproduction 126
- flowering plants 146-7
- humans 198-9
- liverworts 138
- seaweeds 138
- Shakta Pantjukkina 383
- Shampoo, medicated 255
- Shannon, Claude
- Shapes, geometry 364-5, 392
- Sharks 159
- Shaula 387, 388
- Sheep 166
- cloning 265
- lifespan 380
- Sheep ticks 155
- Sheet lightning 292
- Sheetwash 284
- Shellfish, fossils 269
- Shells
- birds' eggs 164
- bivalves 155
- diatoms 133
- mollusks 152
- reptile eggs 162, 163
- tortoises 162
- Shells, electrons 56, 413
- Shelly limestone 279
- Shield volcanoes 275, 315
- Ships 37
- Shoots
- horsetails 139
- internal anatomy 149
- Shores 286-7
- Short-wave radio 48
- Shoulder blade (scapula)
- human skeleton 180, 182, 226
- joint 185
- mammals 166
- pectoral girdle 227
- spine of 210
- Shoulders 180
- artificial joints 253
- bones 182
- joint 185
- muscles 185, 208, 226-7
- pectoral girdle 227
- Shrews 173
- Shrimps, classification 132
- Shrubs
- flowering plants 142
- gymnosperms 140
- SI (Système Internationale) units 11, 18, 377, 413
- Sight 205
- Sigmoid colon 197, 218, 219, 220, 223, 224
- Signals, amplifiers 349
- Silica, lava 275
- Silica gel, desiccators 93
- Silicates
- Earth's composition 270
- on Mars 315
- on Mercury 312
- meteorites 270
- Silicon
- crystals 104
- diodes 346
- in Earth's crust 379
- integrated circuits 350, 351
- periodic table 75, 104
- solar cells 47

- Silicon chips see
Integrated circuits
- Silicon dioxide 68
integrated circuit
manufacture 351
- Silicon oxide 104, 105
- Silicone rubber, artificial
body parts 252
- Silk, spiders 155
- Silt, rivers 284, 285
- Silurian period 268
- Silver
displacement reactions 95
formula 379
periodic table 75
reactivity 94
reactivity with dilute
acids 95
transition metals 102
- Silver bromide,
photographic films
88, 109
- Silver halides 117
photographic films
88, 109
- Silver nitrate
chemical analysis
116, 117
reactivity 95
- Simple attractors, chaos
theory 372
- Simple machines 26-7
- Simple pulleys 27
- Sine, trigonometry 367
- Single bonds, organic
chemistry 112
- Singularity, black holes
350, 351, 413
Big Crunch 353
- Sinkholes 281
- Siphonoglyph,
anemones 150
- Siphons, octopuses 155
- Sipuncula 135
- Sirenia 167
- Sirens (amphibians) 160
- Sirius 329
Hertzsprung-Russell
diagram 325
magnitude 301
spectral absorption
lines 301
star maps 386, 389
- Sistema del Trave 383
- Skeleton
birds 164
bony fish 158, 159
cartilaginous fish 159
mammals 166
tortoises 162
X-ray imaging 241
see also Bones;
Exoskeleton
- Skin
amphibians 160
dolphins 167
drug injections 255
grafts 251
human body 181
reptiles 162
salamanders 161
snakes 165
toads 161
topical drugs 255
- Skin patches, drugs 255
- Skull
birds 164
human skeleton 182,
183, 200, 206
mammals 166
titanium plates 255
trepanning 256, 257
- Sky, color 306
- Slaked lime 101
- Sleeping sickness 259
- Slessor Glacier 385
- Slime molds 134
classification 151
reproduction 135
- Slipher, Vesto Melvin
297, 397
- Slipped disks 247
- Slopes, forces 20
- Slow worm 163
- Slugs 152
classification 132
- Slugs, slime molds 135
- Slumped cliffs 287
- Small intestine 196, 197,
216, 219
- Small Magellanic Cloud
329, 388
- Small-signal diodes 347
- Smallpox vaccine 237, 261
- Smell, sense of 205
- Jacobson's organ 162
- Smith, William 267, 397
- Smoke particles 16
- Smooth muscle cells 122
- Smuts 136
classification 131
- Snails 152
classification 132
internal features 155
speed 380
- Snakelock anemone,
green 150
- Snakes 162, 165
cladistics 133
eggs 165
Jacobson's organ 162
venom 165
- Snellen chart, vision
tests 239
- Snipe 165
- "Snout", glacier 282, 283
- Snow 292
glaciers 282
water cycle 172
- Soap
hard water 100
lather 100
pH scale 84
production of 98, 99
- Soap bubbles
colours 54, 55
surface tension 56
- Societies, scientific 10
- Soda bread 99
- Sodalite 56
- Sodium
atomic diameter 98
characteristics 76
compounds 98
discovery of 67
Downs Process 76, 77
in Earth's crust 379
formation of sodium
chloride 79
formula 379
glass 105
ionic diameter 98
lamps 50
macromolecules 76
melting and boiling
points 379
periodic table 74, 98
reaction with water 98
reactivity 94
salts 86
sodium hydroxide 99
spectral absorption
lines 301
- Sodium bicarbonate
decomposition 99
formula 379
reactions 85
- Sodium carbonate 105
decahydrate 95, 379
- Sodium chlorate
bleaching 110, 111
formula 379
- Sodium chloride 86, 98
characteristics 76
Downs Process 77
formation of 76
formula 379
ionic bonding 78
macromolecules 79
sea water 288
- Sodium dichromate 71
- Sodium
hydrogencarbonate 98
decomposition 99
formula 379
reaction with acid 85
- Sodium
hydrogensulfate 87
- Sodium hydroxide
manufacture 98, 99
neutralization of acid
85, 87
preparation of
nitrogen 106
production of soap 99
- Sodium octadecanoate 99
- Sodium sulfite 109
- Sodium thiosulfate
108, 109
- Soft palate 196, 204
- Software, computers 352
- Soil
bacteria 134
erosion 280
filtering muddy
water 71
fungi 136
nitrogen cycle 172
water cycle 172
- Solar cells 17
electricity generation
46, 47
- Solar eclipses 306,
311, 385
- Solar energy 17, 46, 47
- Solar flares 307
- solar system 304-5
comets, asteroids, and
meteorites 322
data 384
gravity 29
history of
astronomy 296-7
planets 308-21
position in Milky Way
Galaxy 328, 329
space probes 302
Sun 306
- Solar wind
comets 322
magnetosphere 271
- Solder 104, 105
- Soldering irons 105
- Solenoids 45, 413
relays 344
- Solfatara 275
- Solid angles, SI units 377
- Solid shapes, geometry
364, 392
- Solids 34-5
amorphous 34
crystals 16, 34-5
dissolving 16
electromagnetic
radiation 49
melting 32
mixtures 70
particles 32
temperature 32
tension 34, 35
thermal expansion 34
- Solomon/New Britain
Trench 382
- Solstices 271
- Soluble 413'
- Solutes 413
distillation 70, 71
mixtures 70
- Solutions 413
acids and bases 84
alkaline 98
calcium salts 100
chemical analysis 116
chemical reactions 80
concentration 73
dissolving 16
distillation 70, 71
electric charge
carriers 96
filtration 71
mixtures 70
- molar 73
pH scale 84
reactivity 94
sucrose 114
titration 85
- Solvents 413
distillation 70, 71
mixtures 70
water 95
- Soot 85, 112
- Soredium, lichens 137
- Sørensen, Sören Peter
67, 397
- Sound waves
energy 15, 17
frequency 31
ultrasound scanning 240
vibrations 30, 31
wavelength 31
waves 30, 31
- Sounds (body), medical
diagnosis 238
- South America
data 382
formation of 273
mountain building 277
- South American plate 272
- South Celestial Pole 300
- South China Sea, size 382
- South Galactic Pole 329
- South Pole
ice sheet 283
magnetic pole 271
ozone layer 111, 374-5
winds 291
- South Sandwich
Trench 382
- South seeking pole 41
- Southern Cross
constellation 388, 389
- Southern Crown
constellation 388
- Southern Fish
constellation 388
- Southern Triangle
constellation 388
- Sp hybrid orbitals
104, 105
- Space
geometry 364, 365
see also universe
- Space-filling models 68
- Space probes 297,
302-3, 308
asteroids 302
comets 302
costs 10
Jupiter 302, 305, 312
Mars 10, 297, 302, 303
Mercury 312
Moon 302
Neptune 302, 320
Saturn 302, 318
Sun 302
Uranus 302, 318, 319
Venus 305, 312
- Space shuttle 313
- Space telescopes 298
- Space-time 413
black holes 350
geometry 365
theory of relativity
63, 351
wormholes 351
- Spadix flowers 144
- Spain, fold
mountains 277
- Sparrowhawk 165
- Spathes, flowers 144
- Spatulas, medical
diagnosis 239
- Spawn 161
- Special care baby units
256, 257
- Species 413
classification 120, 150-5
communities 168
ecosystems 168
endangered species 175
evolution 128
extinction 128, 174, 175
food chains 170
interactions 169
introduced species 175
natural selection 121
populations 168
- Specimen tubes 239
- Spectral absorption
lines, stars 301
- Spectral type, stars 413
- Spectrographs 413
Hubble Space Telescope
298
- Spectrometers 413
mass spectrometry
116, 117
observing the Sun 506
stars 297
- Spectrophotometers,
space probes 302
- Spectroscopy 67
- Spectrum 413
colors 50
electromagnetic 48-9
stars 300
white light 49
- Speculum, nasal 238
- Speech, brain 187
- Speed 23, 413
acceleration 22, 25
air resistance 24
animals 380
centripetal force 28
cheetahs 167
formula 378
of light 52
measurement 22, 23
velocity 22
winds 385
- Sperm
amphibians 160
chromosomes 265
earthworms 152
fertility treatment 256
fertilization 127
gastropods 155

- human body 189, 198, 199, 222, 225
meiosis 127
Sphenofrontal suture 206
Sphenoid bone 185, 204, 206
Sphenophyta 151, 158
Sphenosquamosal suture 206
Sphenozygomatic suture 206
Sphere, celestial 500
Spheres
elliptic geometry 565
geometry 564, 565, 592
Spheroids, geometry 592
Spherules 510
Sphincters
anal 222, 223, 224, 225
bladder 198
cardiac 197
pyloric 197
Sphygmomanometer 259
Spica 586, 589
Spicules, sponges 150
Spicules, Sun 507
Spiders 154, 155
classification 155
speed 380
Spike flowers 144
Spinal cord
amphibians 160
birds 164
foramen magnum 206
human body 182, 184, 186, 207
lizards 162
magnetic resonance imaging (MRI) 242
mammals 166
microsurgery 249
vertebrae 200, 208
Spinal nerves 208, 413
Spine
cheetahs 167
fish 158
human skeleton 183, 208
mammals 166
posterior view 211
slipped disks 247
snakes 163
see also Vertebrae;
Vertebral column
Spines
cacti 145
fungi 156
sea urchins 151
Spinnerets, spiders 155
Spinning objects,
gyroscopes 28, 29
Spinous process 183, 211
Spiny-headed worms,
classification 155
Spiracles 415
arachnids 155
fish 159
uniramians 156
Spiral bacteria 154
Spiral galaxies 528, 529, 535
Spits, coastlines 286
Spleen 216, 217, 218, 219
functions 195
lymphatic system 192
Splenic cord 195
Splenic flexure 218
Splints, emergency care 245
Sponges 150
classification 152
internal features 150
Spongy bone 182
Spongy mesophyll 149
Sporangia
ferns 159
fungi 156
horsetails 159
liverworts 158
mosses 158
nonflowering plants 158
Sporangiophores 156
Spores 415
ferns 159
fungi 156
gilled mushrooms 137
horsetails 159
liverworts 158
nonflowering plants 158
slime molds 155
Sporophyte generation 158
ferns 159
Sporozoa 151
Sporozoans,
classification 151
Sporozoites 259
Spring (season) 271
Spring equinox 271, 500
Springs, waves and oscillations 50
Springs (water) 284
hot springs 275
Squamosal suture 206
Squamous epithelial cells 122
Squared numbers 360, 361
algebra 562
Pythagorean theorem 566
Squares, geometry 564, 592
Squid 152, 155
classification 152
Squirrels
energy requirements 580
homes 580
Stability 29
Stacks, coastlines 286, 287
Stainless steel 102
Stamens 143, 144, 147, 415
Standard temperature and pressure (STP) 73, 415
Stapes 205
artificial 255
Starch
digestion of 89
molecules 114
photosynthesis 148
Starfish, classification 155
Starling, Ernest Henry 179, 397
Stars 324-5
constellations 524, 586-9
data 384
Döppler shift 501
galaxies 328-9
history of astronomy 296, 297
life cycles 526-7
magnitude 500, 501, 524, 525
neutron stars 550
observational techniques 500
planets 508
spectral absorption lines 501
spectrum 297
Sun 506-7
telescopes 298
Statements, logical 370
States of matter 415
gases 52
liquids 52
solids 52
supercooled liquids 52
and temperature 52
Static electricity 40
Statistics 568-9
history 558, 559
Stator 46
Steam
electricity generation 46
geothermal power 47
nuclear power stations 59
Steel
alloys 102
cathodic protection 95
expansion 54
manufacture 105
radiation from hot objects 49
Stele, roots 149
Stem cells 250
Stem succulents 145
Stems
gilled mushrooms 137
herbaceous flowering plants 142
woody flowering plants 142
Stensen, Niels 266, 267, 397
Step-down transformers 345
Step-up transformers 345
Steradian, SI units 377
Stereotactic microsurgical rig 249
Sternum
birds 164
bone marrow 250
human skeleton 182, 208, 209, 215
Stethoscopes 244
listening to body sounds 258
measuring blood pressure 259
Stickhorns,
classification 151
Stigma 143, 144 415
insect-pollinated plants 146
pollination 146, 147
wind-pollinated plants 146
Stimulated emission 56
Stings
insects 156
scorpions 155
Stinkhorn 156
Stipules 147
Stolons, herbaceous flowering plants 142
Stomach
amphibians 160
birds 164
cardia of 220
crustaceans 154
echinoderms 151
fish 158
functions 197
gastropods 155
human body 196, 197, 216, 217, 218, 219
lizards 162
mammals 166
Stomata
leaves 148, 149
pine needles 141
Storms
hurricanes 295
hydrographs 284
on Jupiter 516, 517
lightning 292
on Mars 514, 515
STP see Standard temperature and pressure
Strange attractors, chaos theory 572
Strassmann, Fritz 15, 597
Stratocumulus clouds 292
Stratosphere 290
Stratum, rocks 276, 415
Stratum basale 181
Stratum corneum 181
Stratum granulosum 181
Stratum lucidum 181
Stratum spinosum 181
Stratum clouds 292
Strawberries 142
Streamlined 415
birds 164
Streams 284
limestone caves 281
Stress 415
Stress analysis, polarized light 54, 55
Striations, muscle fibers 184
Strike, folds 277
Strobilus, horsetails 159
Stroma, chloroplasts 148
Strong nuclear force 415
grand unified theory 15
nuclear physics 58
particle physics 60
Strontium
fireworks 101
periodic table 74, 100
Structure, solids 16
Stump, coastlines 287
Styles 145, 144, 415
fertilization 147
insect-pollinated plants 146
Stylets, fleas 157
Styloid process 204, 206
Subarachnoid space 186
Subatomic particles
discovery of 15
particle physics 60-1
Subcapsular sinus, lymph nodes 193
Subcostal nerve 221
Subcutaneous injections, drugs 255
Subduction zone 275, 415
mid-oceanic ridges 288
Sublimation 52, 110, 415
Sublingual gland 196
Submandibular gland 196, 201, 205
Subphyla, classification 153
Subsets, set theory 571
Substances, state of matter 52
Substrates, enzymes 125
Subtraction, computers 570
Subtractive process, color 50, 415
filters 51
Subtropical jet streams 291
Succulents 145
Suckers, octopuses 155
Suckling, mammals 166
Sucrose
crystals 114
dehydration 92
formula 579
photosynthesis 148
Sugars
digestion of starch 89
DNA 115
fermentation 88, 89
formula 579
liver and 179
molecules 114
photosynthesis 100, 148
sucrose 114
sugar cane 175
surface catalysis 89
Sulcus 187, 206
Sulcus terminalis 205
Sulphates
formula 579
salts 86
sea water 288
Sulfides
formula 579
hydrogen sulfide 108
Sulfur 108-9
allotropes 108, 109
chemical reactions 69
compounds 108
discovery of 579
iron and sulfur mixture 69
iron sulfide 68
periodic table 75, 108
rings 108, 109
sodium thiosulphate 109
sulfataras 275
Sulfur oxides,
acid rain 174
Sulfuric acid
dehydrating agent 92
hydrogen chloride gas 85
neutralization 87
preparation of chlorine 110
preparation of nitrogen 106
rate of reaction 81
salts 86
on Venus 515
Sumatra 582
Sumerians,
mathematics 559
Summer 271
Sun 506-7, 525
celestial sphere 500
Copernicus's theory 9
data 585
and Earth's atmosphere 290
Earth's seasons 271
eclipses 506, 511, 585
energy flow 170
flares 507
global warming 174
gravity 22, 25
history of astronomy 296
infrared astronomy 299
and the Moon 510
natural cycles 172-5
nuclear physics 58
orbit of planets 29
radiation 110, 111
size 504, 505
solar power 17, 46, 47
solar system 504-5
solar wind 271
space probes 502
spectral absorption lines 501, 506
sunspots 506, 507
temperature 52
transits 512
water cycle 172
Sunflower 144
Sunlight 506
oxygen cycle 175

- photosynthesis 100, 125, 148
 Super proton synchrotron (SPS) ring 61
 Superclusters, galaxies 528
 Supercomputers 8
 Superconductors 15
 Supercooled liquids, particles 52
 Superficial muscles 184, 185, 414
 forearm and hand 228, 229
 head and neck 200, 202, 205
 lower leg and foot 252, 253
 shoulder and upper arm 226, 227
 thighs 250, 251
 trunk 209, 210
 Superficial palmar arch 228
 Supergiant stars 325, 327, 351
 Supergranules, Sun 507
 Superior, Lake 385
 Superior articular facet 211
 Superior articular process 211
 Superior sagittal sinus 207
 Superior tarsus ligament 200
 Supernovae 550, 414
 observational techniques 500
 remnants 526, 527
 stellar life cycles 526, 527
 Suppositories 255
 Supramarginal gyrus 206
 Supraorbital foramen 206
 Supraorbital nerve 202
 Suprasternal notch 181
 Sural nerve 235
 Surface catalysis 88-9
 Surface tension 414
 bubbles 56
 cohesive forces 56
 Surfaces 24
 Surgeons 246-7
 training 249
 Surgery 246-7
 anesthetics 257
 artificial body parts 252-5
 cesarian section 256
 history 178
 minimally invasive 248-9
 prehistoric 256, 257
 transplants 246, 250-1
 Sushruta 257, 397
 Suspended load, rivers 285
 Suspension, mixtures 70, 414
 filtration 70
 Suspension, turning forces 21
 Suspensory ligament of penis 225
 Sutures, skull 185, 206
 Sutherland Falls 585
 Swammerdam, Jan 179
 Swan constellation 386
 Swash, waves 287
 Sweetlip fish 169
 Swifts, speed 380
 Swim bladder, fish 158, 159
 Swimming
 birds 164
 fish 159
 Switch gear 46
 Switches
 circuit symbol 559
 computers 552
 electric circuits 45
 integrated circuits 550
 relays 344
 transistors 549
 Swordfish constellation 588
 Symbiosis 168, 414
 fungi 156
 lichens 156, 157
 parasitism 169
 Symbols
 electronic circuits 559, 541, 545, 545, 547, 590
 mathematics 595
 periodic table 75-6
 physics 578
 transistors 549
 Symmetry
 cnidarians 150
 echinoderms 150
 Sympathetic trunk 215, 221
 Sympathetic trunk ganglion 215
 Symphyla 152
 Symphysis pubis 225, 224
 Symptoms 258, 258, 414
 Synapses 184
 Syncline, folds 277
 Syringes, vaccines 261
 Systemic circulation 190, 191
 Systems 414
 Systolic pressure, blood pressure 259
- T**
 T cells
 Human
 Immunodeficiency Virus (HIV) 258
 immune system 260
 thymus gland 192
 and transplants 250
 Table Mountain constellation 588
 Tablets, drugs 254, 255
 Tadpoles 160, 161
 Taenia coli 197
 Taenia libera 217, 218, 219
 Taenia orientalis 217, 218
 Tagging animals, conservation 175
 Tailraces, hydroelectric power stations 46
 Tails
 amphibians 161
 birds 164
 cheetahs 167
 comets 522
 crocodilians 165
 dolphins 167
 fish 158, 159
 lizards 165
 tadpoles 161
 toiseis 162
 Takla Makan Desert 585
 Talc 279
 Talons, birds 165
 Talus 281
 Tanganyika, Lake 585
 Tangents, trigonometry 567
 Tantalum 74
 Tap roots 149
 Tapeworms 152
 classification 152
 Tarantula 155
 Tardigrada 155
 Tarsal bones 182, 252
 Tarsiers 167
 Tarsometatarsus, birds 164
 Tarsus, spiders 155
 Tasmanian devil 167
 Taste
 Jacobson's organ 162
 taste buds 205
 Taurus constellation 386, 588
 Tawny owl 170
 Taxonomy 150, 152
Taxus baccata 140
 Tear faults 276
 Technetium
 discovery of 67
 periodic table 74
 Technology 8
 Tectonic plates 267, 272-3, 414
 earthquakes and volcanoes 274-5
 faults and folds 276-7
 on Mars 515
 metamorphic rocks 278
 mid-oceanic ridges 288
 on Miranda 519
 mountain building 277
 ocean currents 269
 Teeth
 crocodilians 165
 false 255
 human body 196, 197, 200
 jawless fish 159
 mammals 166
 sharks 159
 snakes 165
 Teflon, structure 379
 Telegraph 267
 Telephones, computer networks 554, 555
 Telescopes 297, 298-9
 Galileo's 297
 history of astronomy 297
 Newton's 296, 297
 observing the Sun 506
 Television 57
 cathode-ray tubes 56, 57, 556
 Tellurium 75
 Telophase, mitosis 126
 Temperate 414
 forests 168
 grasslands 168
 rainforests 168, 580
 Temperature 32-5, 414
 atmosphere 290
 Boyle's Law 58
 Charles' Law 59
 chemical reactions 80
 decomposition 80
 electromagnetic radiation 49
 equalization of 55
 filament lamps 50
 gases 58-9
 heat 90
 historical theories 14-15
 measurement 52
 melting and boiling points 579
 Pressure Law 59
 scales 376
 SI units 577
 solids 54
 standard temperature and pressure (STP) 75
 stars 524, 525
 on Venus 515
 weather 292
 weather fronts 295
 see also Body temperature
 Temporal bone 185, 206
 Temporal lobe 206, 207
 Ten 577
 powers of 577
 Tendinous intersection 209
 Tendons 184, 414
 abductor pollicis longus 229
 achilles 185, 253
 biceps brachii 226, 228
 calcaneal 185, 253
 extensor carpi radialis brevis 229
 extensor carpi radialis longus 229
 extensor carpi ulnaris 229
 extensor digiti minimi 229
 extensor digitorum 229
 extensor digitorum brevis 235
 extensor digitorum longus 185, 252, 253
 extensor hallucis 235
 extensor hallucis longus 185, 252
 extensor indicis 229
 extensor pollicis brevis 229
 extensor pollicis longus 229
 flexor digitorum brevis 252
 flexor digitorum superficialis 228
 flexor hallucis brevis 252
 flexor hallucis longus 252
 lumbrical 229
 palmar interosseus 229
 palmaris longus 228
 peroneus tertius 252, 253
 surgery 247
 tibialis anterior 252, 253
 triceps brachii 227
 Tension 414
 centripetal force 28
 oscillation 50
 solids 54, 55
 surface 56
 Tension force, inclined planes 26
 Tentacles
 cnidarians 150
 octopuses 155
 Tepals, flowers 145, 144
 Terbium 75
 Terminal bronchioles 195
 Terminal moraine 282, 285
 Terminal velocity 24, 414
 Terraces, glacial erosion 285
 Terrapins 162
 Terrestrial 414
 Terrestrial planets
 504, 508
 Mars 514
 Mercury 512
 Venus 512-15
 Tertiary bronchus 215
 Tertiary period 269
 Testa, seeds 146, 147, 414
 Testes
 amphibians 160
 annelid worms 152
 functions 199
 human body 198, 222, 223
 sex hormones 188, 189
 Testosterone 189
 Tests
 chemical analysis 116
 chlorine in water 111
 flame tests 116
 gas chromatography 70
 medical diagnosis 258-9
 paper chromatography 70
 pregnancy 256
Testudo radiata 162
 Tetanus 581
 vaccine 261
 Tethys Ocean 275
 Tetragonal system, crystals 54
 Tetrahedrons 564, 592
 Tetrapods 166
 Thalamus 187, 207
 Thallium 75
 Thalloid liverworts 158
 Thallus
 lichens 157
 liverworts 158
 seaweeds 158
 Thar Desert 585
 Theophrastus 120, 597
 Theorems 558
 Pythagorean theorem 558, 559, 566, 567
 Theories 9, 18
 Thermal expansion 54, 414
 Thermionic emission, cathode-ray tubes 556
 Thermistors 74
 Thermite reaction 90, 91
 Thermocouples 414
 electronic thermometers 259
 Thermometers 71
 body temperature 259
 digital 19
 measuring heat 18
 mercury 19
 Thermoplastics 114
 Thermosetting plastics 114
 Thermosphere 290
 Theropods 128
 Thiamine 581
 Thighs 181
 muscles 250-1
 Thin film interference 55
 Thistle funnels 85
 Thomson, Joseph John 15, 357, 397
 Thoracic cavity 212, 215, 216
 Thoracic lymphatic duct 192
 Thoracic nerves 186
 Thoracic vertebrae
 human skeleton 182, 185, 211
 mammals 166
 Thoracolumbar fascia 208, 210
 Thorax 414
 crustaceans 154
 human body 180, 194-5, 208, 212-15
 mammals 166
 Thorium 74
 Thornback ray 159

- Thousand 377
 Thread, surgical 246
 Three-dimensional
 shapes, geometry 364
 Throat 200, 205
 diagnosis 238
 digestive system 196
 respiratory system 194
 Thulium 75
 Thumbs 180
 bones 228
 joint 185
 muscles 228
 myoelectric arms 253
 Thunderstorms 292, 295
 Thylakoids 148
 Thymine 115
 Thymus gland 192
 Thyristors 349
 Thyrocervical trunk 214
 Thyrohyoid ligament 194
 Thyroid cartilage 194,
 204, 205
 Thyroid gland 189, 204,
 205, 214
 functions 188, 189
 positron emission
 tomography (PET) 245
 Thyroid-stimulating
 hormone 188
 Thyroxine 189
 Tibia
 fractures 241
 human skeleton 182,
 232, 235
 joint 185
 mammals 166
 spiders 155
 Tibial nerve 186, 251, 253
 Tibiotarsus, birds 164
 Ticks 154, 155
 classification 135
 Tides
 coastlines 286
 estuaries 284
 historical theories 266
 tidal power 47
 Tiger salamander 160
 Tigers 166
 classification 130
 energy requirements 380
 Time
 Big Bang 332
 black holes 350, 351
 freefall experiment 19
 geological 268-9
 measurement 18
 SI units 377
 theory of relativity 62, 63
 Tin 104
 alloys 104, 105
 bronze 105
 element 68, 76
 periodic table 75, 104
 reactivity 94
 reactivity with dilute
 acids 95
 solder 105
- Tissue 414
 analysis 257, 259
 transplants 250-1
 Titania 308
 Titanium 74
 Titration 414
 acid salts 86
 hardness of water 100
 neutralization of an
 acid 85
 Toads 160, 161
 feet 160
 metamorphosis 161
 Toes
 birds 165
 bones 232
 human body 181
 nails 181
 Tombaugh, Clyde
 William 297, 397
 Tonga-Kermadec
 Trench 382
 Tongue
 human body 205, 215
 muscles 204
 reptiles 162
 swallowing 196
 Tonoplast membrane 125
 Tons 376, 377
 Tonsils 192
 lingual tonsil 204,
 205, 215
 palatine tonsil 204
 pharyngeal tonsil 204
 Topaz 279
 Topical skin
 preparations 255
 Topological 414
 Topology 365
 Toroidal transformers 345
 Torricelli, Evangelista
 15, 397
 Tors 281
 Torso see Trunk
 Tortoises
 lifespan 380
 skeleton 162
 speed 380
 Torus, geometry 392
 Total internal reflection
 52, 414
 binoculars 52
 Toucan constellation 398
 Touch 187
 receptors 181
 Tower of Hanoi 370
 Toxoplasmosis 259
 Trabecula
 lymph nodes 195
 spleen 195
 Trachea
 birds 164
 breathing 195
 cartilage 204, 215, 215
 cross section 215
 human body 194, 196,
 200, 204, 205, 212, 214
 larynx 194
- lizards 162
 lungs 215
 mammals 166
 Tracheal bifurcation 215
 "Trade" winds 291
 Traditional systematics,
 classification 132
 Transcription, protein
 synthesis 124, 125
 Transcurrent faults 276
 Transducers 414 -
 echocardiography 240
 myoelectric arms 253
 Transfer of energy 17
 Transformers 344-5
 hydroelectricity 46
 nuclear power stations 59
 Transfusions, blood 237
 Transistors 348-9
 computers 337, 352
 diodes 346
 electronic circuits 358
 history 337
 integrated circuits 550
 semiconductors 336
 Transition metals
 102-3, 414
 catalysts 88
 periodic table 74-5
 Transits, planetary 312
 Translation, protein
 synthesis 124, 125
 Transmission 52
 Transpiration, leaves 149
 Transplant surgery 246,
 250-1, 414
 heart 237, 246
 rejection 250
 Transuranic elements 75
 Transverse colon 196,
 197, 216, 217, 218, 219
 Transverse crevasses 282
 Transverse dunes 280
 Transverse fascia 209
 Transverse foramen 211
 Transverse line,
 sacrum 211
 Transverse process,
 vertebrae 183, 211
 Transverse waves 30
 Trapezium, geometry 392
 Traveling microscopes 18
 Tree ferns 268
 Tree frogs 160
 Tree wasps 157
 Trees
 acid rain 174
 epiphytes 145
 flowering 142
 gymnosperms 140
 weathering and
 erosion 280
 Trematoda 132
 Trenches, ocean 288,
 289, 382
 Trepanning 236, 237
 Triangles
 area and volume 393
- elliptic geometry 365
 fractals 372
 geometry 364
 hyperbolic geometry 365
 mathematics 366-7, 392
 Triangulum Australe
 constellation 388, 389
 Triangulum
 constellation 387, 388
 Triassic period 269
 Tributaries, rivers 284
 Triclinic system, crystals 35
 Tricuspid valves 191
 Trigger hairs,
 carnivorous plants 145
 Trigonal system, crystals 35
 Trigonometry 366-7, 393
 Trillion 377
 Trilobites 268, 269
 Triodes 356
 Triple bonds, organic
 chemistry 112
 Trisomy, chromosome
 abnormalities 263
 Triton 302
 Triturus cristatus 161
 Trolleys, emergency
 care 245
 Trophic levels, food
 chains 170
 Trophic pyramid, food
 chains 170
 Tropical 414
 Tropical cyclones 293
 Tropical rainforests
 life zones 168
 primary production 380
 Tropics 291
 Troposphere 290, 292
 Troughs, folds 277
 True vocal cords 194
 Truffles
 classification 131
 summer truffle 136
 Trunk 414
 human body 180, 208-11
 Tsiolkovsky crater,
 Moon 311
 Tuataras 162
 Tube feet,
 echinoderms 151
 Tubercle of rib 211
 Tubers, succulents 145
 Tubes, liquids in 36
 Tubules, kidneys 198
 Tucana constellation 388
 Tugela Falls 383
 Tumors
 positron emission
 tomography (PET) 243
 X-ray imaging 241
 Tundra, life zones 168
 Tuned circuits 345
 Tungsten
 discovery of 379
 melting and boiling
 points 379
 periodic table 74
- transition metals 102
 Tunica albuginea 222
 Tunica vaginalis 222
 Tuning fork 31
 Tupungatito 383
 Turbellaria 132
 Turbines 414
 geothermal power 47
 hydroelectricity 46
 nuclear power stations 59
 tidal power 47
 wind power 47
 Turbulence, chaos
 theory 372
 Turning forces 21
 formula 378
 rollers 24, 25
 screws 26
Turstopis truncatus 167
 Turtles 162
 cladistics 133
Turycecus lamellata 154
 Tusk shells,
 classification 132
 Tweezers 246
 Twins constellation 386
 Two-dimensional
 shapes, geometry 364
 Tycho crater, Moon 311
 Tympanic membrane 205
 Typhoons 293
- U**
 U-shaped valleys 283
 Ulna
 birds 164
 human skeleton 182,
 226, 228, 229
 joint 185
 Ulnar nerve 186, 226,
 227, 228, 229
 Ultrasound 415
 echocardiography 240
 medical imaging 237, 240
 Ultraviolet (UV) 415
 astronomy 299
 atmosphere 290
 electromagnetic
 spectrum 49, 299
 fluorescence 56-7
Hubble Space Telescope
 298
 integrated circuit
 manufacture 351
 nebulae 327
 ozone layer 174, 290
 Sun 307
 Umbel, flowers 144
 Umbilical cord 199
 Umbilicus 180, 209
 Umbra 306, 310
 Unconsciousness,
 general anaesthetics 247
 Unicellular 134, 415
 Union, set theory 371
 Uniramia 132, 154
 Uniramians 154, 156
- classification 132
 Unit cells 34, 415
 United States Defense
 Department 337
 Units of temperature 32
 Universal indicator
 paper 84
 Universal set, set
 theory 371
 Universe
 Big Bang theory
 297, 352
 cosmology 332-5
 creation myths 8
 galaxies 328-9
 geocentric model 314
 history of astronomy 296
 wormholes 331
 Universities 11, 14
 Unnilennium 74
 Unnilhexium 74
 Unniloctium 74
 Unnilpentium 74
 Unnilquadium 74
 Unnilseptium 74
 Unreactive elements 74
 Unukalhai 389
 Upquarks 60
 Upthrust 415
 hot-air balloons 39
 immersed objects 36, 37
 Upward meniscus 36
 Uranium
 instability 75
 nuclear power 59
 periodic table 74
 Uranus 318-19
 data 384
 discovery of 297
 moons 308, 385
 rings 308, 318, 319
 size 304
 space probes 302,
 318, 319
 Urea
 discovery of 67
 mammals 166
 Urea-methanal 114
 Ureters
 birds 164
 female 224
 human body 198, 217,
 220, 221
 lizards 162
 male 223
 mammals 166
 Urethras 198, 199, 222
 external orifice 223,
 224, 225
 membranous 223
 penile 223
 prostatic 223
 Urinary bladder see
 Bladder
 Urinary system 198
 Urine 415
 human body 188, 198,
 222, 225

- mammals 166
 pregnancy tests 256
 Urochordata 133
 Urogenital diaphragm 222, 225
 Ursa Major constellation 386, 387, 389
 Ursa Minor constellation 386
 Urubupunga Falls 383
 Uterus (womb) 166, 198, 415
 childbirth 257
 fundus 224
 in-vitro fertilization 256
 menstrual cycle 225
 pregnancy 199
 Utgaard 385
 Uvula 204
- V**
- Vaccines 261, 415
 development of 237
 genetic engineering 262
 Vaccuoles
 amoebas 135
 plant cells 123
 Vacuums
 air pumps 66
 ammonia fountain 95
 cathode-ray tubes 57, 336
 Ventouse extraction, childbirth 256, 257, 415
 Vagina 198, 224, 225
 birth 199
 sexual intercourse 199
 suppositories 255
 vaginal opening 224, 225
 Vagus nerve 207, 214
 Valles Marineris, Mars 315
 Valleys
 erosion 279, 285
 glaciers 282, 285
 hanging 282, 285
 rivers 284
 Valves, electronic 336
 Valves (heart) 191
 mechanical 252, 253
 transplants 251
 Valves, lymph nodes 193
 Van de Graaff generators 40-1, 343
 Vanadium 74
 Vaporization
 bromine 110
 fractional distillation 113
 gas chromatography 70
 iodine 110
 Variable capacitors 343
 Variable resistors 44, 341
 Variable stars 325
 Variables, algebra 362-3, 415
 Variation
 evolution 128
- heredity 127
 Varicose veins 381
 Vas deferens 198, 199, 222, 223
 Vascular grafts 252, 253
 Vascular system 415
 echinoderms 151
 ferns 139
 human body 190-1
 nonflowering plants 138
 plant-transport systems 148, 149
 Vauquelin, Nicolas-Louis 379
 Vectors 415
 Cartesian coordinates 366
 vector coordinates 367
 Vega 328, 387, 388
 Veins 190, 193, 202
 angular 202
 arcuate 198
 axillary 190, 205, 226
 azygos 213, 215
 basilic 226, 228, 229
 brachial 190, 226
 brachiocephalic 205, 212, 213, 214, 215
 cardiac 213
 cephalic 190, 205, 209, 226, 228, 229
 cerebral 207
 dorsal digital 190
 dorsal metatarsal 190
 facial 202, 205
 femoral 190, 250
 gonadal 220
 greater occipital 202
 hemiazygos 215
 hepatic 196, 217, 220, 221
 hepatic portal 190, 217, 219
 hypophyseal portal 188
 iliac
 common iliac 190, 216, 220, 230
 external iliac 220, 221, 224, 230
 internal iliac 223, 224
 inferior vena cava see vena cava
 insect wings 156
 intercostal 213, 215
 jugular 200
 external jugular 202, 205
 internal jugular 190, 192, 202, 205, 212, 213, 214, 215
 lymph nodes 193
 mesenteric 218
 inferior mesenteric 219
 superior mesenteric 219
 occipital 202
 ovarian 224
 popliteal 190, 231, 233
 portal 219
 pulmonary 190, 191, 212, 213
 radial 190
 renal 190, 198, 220
 retromandibular 202
 saphenous 190, 230, 233
 great saphenous 233
 small saphenous 231, 233
 splenic 193, 219
 subclavian 190, 192, 205, 213, 214, 215
 submental 205
 superficial temporal 202
 superior mesenteric 219
 superior temporal 202
 superior vena cava see vena cava
 thyroid 202, 205
 tibial 190, 233
 ulnar 190
 vena cava 191
 inferior vena cava 190, 215, 216, 217, 218, 220, 221, 230
 superior vena cava 190, 212, 213, 214, 215
 Veins, leaves 145, 149
 Vela constellation 386, 388
 Vela Supernova Remnant 327
 Velocity 22, 415
 momentum 25
 terminal 24
 theory of relativity 62
 Venn diagrams 359, 370, 371
 Venom
 insects 156
 scorpions 155
 snakes 163
 Venous sinus, spleen 193
 Ventilators, intensive care units 245
 Ventral nerve cord, insects 156
 Ventral root, spinal cord 186
 Ventricles
 brain 207
 echocardiography 240
 heart 190, 191, 212, 213, 214
 Ventricular systole 191
 Vents, volcanoes 275
 Venules, pituitary gland 188
 Venus 312-13
 data 384
 orbit 29, 304, 313
 size 305
 space probes 303, 312
 Venus flytrap 145
 Vernier callipers 18
 Vernier scale 415
 Vertebrae
 birds 164
 cervical 182, 183, 200, 211
 coccygeal 182, 183, 200, 211
 fish 158
 human skeleton 182, 183, 211
 lumbar 182, 183, 211, 221
 mammals 166
 sacral 182, 183, 200, 211
 thoracic 182, 183, 211
 tortoises 162
 Vertebral column 182, 183, 203, 208, 215
 see also Coccyx; Sacrum
 Vertebral foramen 211
 Vertebrata 133
 Vertebrates 415
 amphibians 160
 birds 164
 classification 133
 evolution 268
 fish 158
 mammals 166
 reptiles 162
 Vertex, geometry 364
 Very high frequency (VHF) radio 48
 Very large-scale integration (VLSI) 337, 351
 Vesalius, Andreas 178, 236, 397
 De Humani Corporis Fabrica 178-9
 Vestibulocochlear nerve 205
 Vibration
 electromagnetic radiation 49
 frequency 31
 oscillation 30
 sound 30, 31
 thermal expansion 34
 Vicia faba 147
 Victoria, Lake 383
 Victoria Falls 383
 Victoria Island 382
 Video cards, computers 333
 Viking landers, Mars 303
 Villi 197
 Vinegar
 formula 379
 reaction with sodium hydrogencarbonate 85
 Vinson Massif 382
 Violet light 49
 Vipers 163
 Virgin constellation 386, 388
 Virgo constellation 386, 388, 389
 Virtual reality surgery 248, 249
 Viruses 11, 134, 415
 discovery of 121
- diseases 258
 structure 134
 T cells and 250
 Visceral 415
 Vision
 color 50
 seeing by reflected light 52
 tests 259
 Vitamin A 381
 Vitamin B1 381
 Vitamin B2 381
 Vitamin B3 381
 Vitamin B6 381
 Vitamin C 381
 formula 379
 Vitamin D 381
 Vitamin E 381
 Vitreous humor 205
 Vityaz II 382
 Vivisection 178
 Vocal cords 194, 215
 Vocal sacs, frogs 160
 Voice box see Larynx
 Voice coil 31
 Volans constellation 388, 389
 Volcanoes 274-5
 active 385
 atolls 289
 formation of Earth 268
 historical theories 266
 igneous rocks 278
 on Io 316
 island arcs 273, 288
 on Mars 314, 315
 on Moon 311
 plate tectonics 272
 seamounts 288
 on Venus 313
 Voles 170
 Volkman spoons 246
 Volta, Alessandro 15, 66, 397
 Voltage 415
 capacitors 342, 343
 computers 352
 diodes 346, 347
 electric circuits 42
 electrochemistry 96, 97
 electronic circuits 338, 339
 formula 378
 generators 46
 Ohm's Law 42
 potentiometers 341
 resistors 340
 SI units 377
 transformers 344, 345
 transistors 348, 349
 wind power 47
 Voltage dividers 340
 Voltaic cells 96, 97
 Voltmeters, electric circuits 43
 Volts 42, 377
 Volume 415
 Charles' Law 39
- conversion tables 377
 data 393
 gas molar 73
 gases 38-9
 measurements 376
 Volume controls, potentiometers 341
 Volva, gilled mushrooms 137
 Vomer 206
 Vostok 382
 Voyager 2 space probe 302, 318, 319, 320
 Vulpecula constellation 387
 Vulva 180, 224
- W**
- W particles 60
 Wading birds 165
 Walking, arthropods 154
 Wallaby, red-necked 167
 Walrus 167
 energy requirements 380
 Walton, Ernest Thomas Sinton 15, 397
 WANs (Wide Area Networks) 355
 Warm fronts 293
 Washing soda efflorescence 93
 formula 379
 Washington, Mount 382
 Wasps 157
 speed 380
 Water
 as acid 84
 and alkali metals 98
 amphibians 160
 atmosphere 290
 as base 84
 boiling point 32
 capillary action 36
 catalytic converters 89
 in chemistry 92-3
 chlorination 110, 111
 clouds 292
 coastlines 286-7
 and combustion 83
 concentrations 81
 dehydrating agents 92
 digestive system 196, 197
 distillation 71
 electricity generation 46
 electrolytic decomposition 96
 endothermic reactions 90
 erosion 280
 evaporation 16
 exothermic reactions 90
 fish 158
 formation of Earth 268
 formula 379
 four-elements theory 66
 freezing point 32
 geothermal power 47

- hard water 86, 100
hurricanes 295
hydrogen bonding 78, 79
hydrological science 266
kidneys 220
limestone caves 281
magnetic resonance imaging (MRI) 242
meniscus 56
mineral water 86, 87
as mixture 70
molecular model 68
on Neptune 520
nuclear power stations 59
oceans 288-9
pH scale 84
photosynthesis 100, 148
pollution 174
preparation of
chlorine 110
preparation of
oxygen 108
pressure 37
reaction with sodium 98
reactivity 94
respiration 124
rivers 284-5
rock cycle 278-9
rusting of iron 82
salts 86, 87
sea water 288
solutions 16, 70
as a solvent 95
storm hydrographs 284
succulents 145
surface tension 36
tidal power 47
transpiration 149
upthrust 37
urinary system 198
vapor 106
water cycle 172, 267
water table 284
wave behaviour 54
waves 287
- Water bears,
classification 155
Water birds 164
Water Carrier
constellation 388
Water of crystallization
92, 415
copper chloride 102
efflorescence 95
hygroscopy 95
monohydrates 95
sodium thiosulfate 109
Water fleas 154
classification 155
reproductive strategy 169
Water hyacinth 145
Water molds 134
classification 131
Water Snake
constellation 586, 388
Water vascular system,
echinoderms 151
Waterfalls 284
formation of 285
hanging valleys 285
highest 385
rock cycle 278
Watersheds 284
Watson, James Dewey
121, 597
Watts 377
Wavelengths 50, 415
colours 50
electromagnetic
radiation 48-9
sound waves 51
white light spectrum 49
Waves 50-1, 415
behavior 54-5
electromagnetic
radiation 48
interference 54
light 55
oscilloscopes 339
plane 54
Principle of
Superposition 54
quantum theory 62
sound 50
in springs 50
Waves (water)
coastlines 286
oceans 287
Wax
candle wax 78, 85
fractional distillation 115
Weak interaction 15,
60, 415
Weasels 170
Weather 292-5
atmospheric science 266
balloons 290
chaos theory 372
historical theories 266
maps 295
meteorology 267
records 382
winds 291
Weathering
rock cycle 278
rocky landscapes 280-1
Web pages, computer
networks 355
Webbed feet
amphibians 160
duck-billed platypus 167
wading birds 165
water birds 164
Webs, spiders 155
Wedges 26
Wegener, Alfred 267, 397
Weight 415
air resistance 24
component 20
formula 378
lifting with pulleys 27
measurement 18
resultant force 20
upthrust 37
Weights and
measures 376-7
Welding metals
52, 90, 91
Welwitschia mirabilis 11,
140
Westerly winds 291
Wet, four-elements
theory 66
Wetland plants 145
Wezen 586, 589
Whales 166, 167
lifespan 380
Wheels
axles 27
ball bearings 25
Whelks 171
Whisk ferns,
classification 131
White blood cells
functions 191
lymphocytes 250
stem cells 250
White dwarf stars
325, 327
White light
additive process 51
color vision 50
destructive
interference 54-5
radiation from hot
objects 49
spectrum 49
White matter 186,
187, 207
White Oval, Jupiter
516, 517
White phosphorus 106
White pulp, spleen 195
Whole numbers 360, 415
Whooping cough
vaccine 261
Width 18
Wildlife reserves 175
Wilhelm, Mount 582
Wilson, John Tuzo
267, 397
Wilson, Robert Woodrow
297, 397
Wind pollination 146
flowering plants 144
pine trees 141
Windpipe see Trachea
Winds
erosion 280
global circulation 291
hurricanes 295
on Mars 514
ocean currents 288, 289
rock cycle 278
speed 385
water cycle 172
waves 287
wind farms 47
wind power 46-7
Winged seeds,
conifers 141
Wings
bats 167
birds 164, 165
butterflies and moths 157
evolution 129
insects 156
Winter 271
Wire
electricity generation 46
electromagnetism 44-5
Wishbone, birds 164
Wöhler, Friedrich 67,
397
Wolf constellation 588
Womb see Uterus
Wombats 167
Wood
burning 32
woody flowering
plants 142
Wood mouse, yellow-
necked 170
Woodlands, food
chains 170
Woodlice, classification 132
Work 415
formula 378
simple machines 26
Workers, tree wasps 157
World Conservation
Union 175
World Wide Web 354, 355
Worm gear 17
Wormholes 330, 331
Worms 152
classification 132, 135
infections 258
Wounds, emergency
care 244
Wrasses 169
Wrench faults 276
Wrist 180
artificial joints 253
bones 228, 229
muscles 185, 228
- ## XYZ
- X-plates,
oscilloscopes 339
X rays 49, 415
astronomy 299
barium meals 100, 101
black holes 330, 331
cathode-ray tubes 336
computerized
tomography 241
crystallography 67
discovery of 15
electromagnetic
radiation 48
electromagnetic
spectrum 49, 299
medical diagnosis 49,
237, 240, 241
Xenon 75
Xerophytes 145
gymnosperms 140
Xiphoid process 182
Xinor gate 390
XOR gate 370, 390
Xylem cells, plant-
transport systems 123,
148, 149
Y-plates,
oscilloscopes 339
Yangtze River 385
Yap Trench 382
Yard, unit of
measurement 376, 377
Yeasts 136
classification 151
fermentation 89
Yellow bile,
"humors" 236
Yellow-green algae,
classification 131
Yellow light
additive process 51
sodalite 56
subtractive process 51
white light spectrum 49
Yellow pigments 70
Yellow River 285, 385
Yellowstone Park 175
Yew 140
Yin and yang 236
Yolk sac, birds' eggs 164
Yosemite Falls 385
Ytterbium 75
Yttrium 74
Z particles 60
Zaire, River 385
Zero 358, 359, 360
Zinc
alkaline dry cells 96
displacement reactions 94
formula 379
periodic table 75
reactivity 94
reactivity with dilute
acids 95
voltaic cells 97
Zinc sulphate 94
Zirconium 74
Zona pellucida 127
Zoology, history 120
Zooplankton 171
Zubenelegubi 386, 389
Zubeneschamali 386, 389
Zygomatic arch 201, 206
Zygomatic bone 183,
204, 206
Zygomycota 131
Zygotes 415
fertilization 127
heredity 127
human reproduction 199
nonflowering plants 138
Zymase 89

Acknowledgments

DK Publishing would like to thank:

DK Publishing would like to say a special thank you to Lara Maiklem for efforts way above and beyond the call of duty: at times editor, project editor, and senior editor in one.

Physics

Griffin and George, Loughborough (scientific equipment); University College, London (glassware); Maplin electronics, Hammersmith; Kensington Park School, Kensington

Chemistry

The Hall School, South Hampstead and Imperial College, London for use of their laboratories; University College, London; Kensington Park School, Kensington

Life Sciences and Ecology

Philip Harris Education, Staffordshire (loan of models and advice); Diana Miller; Lawrie Springate; Karen Sidwell; Chris Thody; Michelle End; Susan Barnes and Chris Jones at the EMU Unit of the Natural History Museum, London; Jenny Evans at Kew Gardens, Surrey; Kate Biggs at the Royal Horticultural Gardens, Surrey; Spike Walker of Microworld Services; Neil Fletcher; John Bryant of Bedgebury Pinetum, Kent; Dean Franklin; Clare Roe; Roy Flooks; David Manning's Animal Ark; Intellectual Animals; Howletts Zoo, Canterbury; John Dunlop; Alexander O'Donnel; Sue Evans at the Royal Veterinary College, London; Dr Geoff Potts and Fred Frettsome at the Marine Biological Association of the United Kingdom, Plymouth; Jeremy Adams at the Booth Museum of Natural History, Brighton; Derek Telling at the Department of Anatomy, University of Bristol; the Natural History Museum, London; Andy Highfield at the Tortoise Trust; Brian Harris at the Aquarium, London Zoo; the Invertebrate Department, London Zoo; Dr. Harold McClure at the Yerkes Regional Primate Center, Emory University, Atlanta, Georgia; Neilson Lausen at

the Harvard Medical School; New England Regional Primates Research Center, Southborough, Massachusetts; Dr. Paul Hopwood at the Department of Veterinary Anatomy, University of Sydney

Human Anatomy

Richard Greenland, DK Multimedia

Medical Science

Dr. Sarah Metcalf (bone plate and hip bone replacement); Draeger Medical, Hertfordshire; Carl Zeiss Ltd., Hertfordshire; John Bell and Croyden, London (surgical and medical instruments); Porter Nash, London (bone marrow needle and syringe); Impra (UK) Ltd., Worcestershire (vascular grafts); Dan Humphreys and Richard Walker at the London Ambulance Service for advice and the loan of ambulance equipment

Earth Sciences

Dr. John Nudds, The Manchester Museum, Manchester; Dr. Alan Wooley and Dr. Andrew Clark, The Natural History Museum, London; Graham Bartlett, National Meteorological Library and Archive, Bracknell; Tony Drake, BP Exploration, Uxbridge; Jane Davies, Royal Society of Chemistry, Cambridge; Dr. Tony Waltham, Nottingham Trent University, Nottingham; Staff at the Smithsonian Institute, Washington, D.C.; June Duller; Staff at the United States Geological Survey, Washington, D.C.; Staff at the National Geographic Society, Washington, D.C.; Staff at Edward Lawrence Associates (Export Ltd.), Midhurst; David Lambert

Astronomy and Astrophysics

John Becklake; the Memorial Museum of Cosmonautics, Moscow; the Cosmos Pavilion, Moscow; the US Space and Rocket Center, Alabama; Broadhurst, Clarkson, and Fuller Ltd.; Susannah Massey; Tatyana Alekseyevna

PHOTOGRAPHY:

Dean Belcher, Peter Chadwick, Andy Crawford, Geoff Dann, Bob Gathany, Steve Gorton, Anna Hodgson, Dave King, Tim Ridley

ADDITIONAL PHOTOGRAPHY:

Jane Burton, Judith Harrington, Bob Langrish, Cyril Laubscher, Matthew Ward, Jerry Young

ILLUSTRATORS:

Julian Baum, Rick Blakely, Alison Brown, Joanna Cameron, Kuo Kang Chen, Simone End, Roy Flooks, Mark Franklin, Mick Gillah, Andrew Green, David Hopkins, Selwyn Hutchinson, Nick Loates, Chris Lyon, Janos Marffy, Charles Metz, Claire Naylor, Sandra Pond, Colin Rose, John Temperton, Richard Tibbits, Hali Verrinder, Gareth Wild, Philip Wilson, John Woodcock

MODEL MAKERS:

Simon Murrell, Claire Naylor, Bruce Streater

ADDITIONAL DESIGN ASSISTANCE:

Stephen Croucher

ADDITIONAL EDITORIAL ASSISTANCE:

Julie Oughton, Mukul Patel, Will Hodgkinson

PROOFREADERS:

Fred Gill, Will Hodgkinson

DK Publishing would like to say a special thank you in memory of Fred Gill for all the work he did for DK over the years

INDEX:

Hilary Bird

Some pages in this book previously appeared in the *Visual Dictionary* Series, published by DK Publishing.

Picture credits:

The publisher wishes to thank the following for their kind permission to reproduce their photograph:

c=center; b=bottom; l=left; r=right; t=top

Biofotos Associates: 258cr **British Geological Survey:** 274erb **British Petroleum Co. Plc:** 95tl **British Steel:** 103tl **Bruce Coleman Ltd:** Gerald Cubitt 286tr; Paul van Gaalen 282tr; Kim Taylor 154br; Bill Wood 152bl **Steven J. Cooling:** 277bl, 284br, 284br **Department of Clinical Radiology, Salisbury District Hospital:** 252cl **Galaxy Picture Library:** Michael Stecker 324cr, 326b **Robert Harding Picture Library:** C.Deli 47cr **Philip Harris:** 126clb **The Image Bank:** 292tr; Mel Digiacommo 55crb **Leonard Lessin/Peter Arnold Inc:** 115cl **Lund Observatory:** 328-9 **Microworld Services:** 135cl **NASA:** 264-5c, 291br, 294, 310tr, 313br, 315bl, 315br, 324tr, 326tr, 327tl, 333cr **Goddard Space Flight Centre:** 331br **H. Hammel/MIT:** 317br **JPL:** 308clb, 308bl, 316bl, 316cb, 316crb, 316bc, 316br, 319br, 322tr, 332cr, 355c **Raghvenda Sahai and John Trauger (JPL), the WFPC2 Science Team:** 327tr **Space Telescope Science Institute:** 317bc **National Maritime Museum:** 399bl **National Medical Slide Bank:** 258c **Natural History Museum:** 129bl

Downe House 120-1 NHPA: Stephen Dalton 171br; Jany Sauvanet 161era **Newage International Ltd:** 46tc **NOAO:** 328cb **Oxford Scientific Film:** Breck P. Kent 150cl **London Scientific Films:** 155tr **Oxford University Museum:** 129tl **Pictor International:** 101tl **Premaphotos Wildlife:** K.G. Preston-Mafham 152tr **Press Association, Roslin Institute, Edinburgh:** 263br **Des Reid:** 91cl **Marion Tully:** 34tr **Science Museum:** 14l, 15bl, 15tc, 66l, 66br, 67tc, 120l, 121tl, 178l, 178br, 179tl, 236l, 237bl, 237tc, 248bl, 252bl, 266tl, 267, 296-7bc, 297tc, 336tl, 336bl, 337tc, 339tl, 339tc, 351tr, 398l, 399tc **Science Photo Library:** 240bl, 241tl **Lawrence Berkeley Laboratory:** 60t **Biology Media:** 260tr **BMDO/NRL/LLNL:** 323bc **Dr. Jeremy Burgess:** 134br, 137tr **CERN:** 58bl, 60br, **Charing Cross Hospital, Department of Nuclear Medicine:** 243tl **Prof. S. Ciniti/CNRI:** 261bl **CNRI:** 101tr, 259bl **Custom Medical Stock Photo/ Z. Binor:** 248cb **Barry Dowsett:** 259tc **Malcom Fielding/The BOC Group:** 245br **Simon Fraser:** 47tr, 241bl **Department of Neuroradiology, Newcastle General Hospital:** 243tr **Carlos Goldin:** 240tr **Hale Observatories:** 306tr **George Haling:** 252tr **Dr. William C. Keel:** 328cb **King's College School of Medicine, Department of Surgery:** 241t **Prof. E. Lorentz/Peter Arnold Inc:** 372br, **Dennis Milton:**

323cla **Hank Morgan:** 249tr, 249ca, 256bl, 261cr, 262tr **NASA:** 111tr, 273br, 320crb, 320br, 323tl **NIBSC:** 258crb **Omikron:** 12-3c, 60cr **David Parker:** 49tc, 276tr, 345br, 351bl **Paul Parker:** 238cl **Alfred Pasieka:** 253br, 254cr, 350br **D. Phillips:** 127bl **Phillippe Plailly:** 78tr, 263bc **Chris Priest:** 247tr **Royal Observatory, Edinburgh:** 328clb **David Scharf:** 250tr **Dr. Rudolph Schild:** 328bl **Blair Seitz:** 258tr **Sinclair Stammers:** 134cr **Stammers/Thompson:** 49bc **Geoff Tomkinson:** 242br **Alexander Tsiaras:** 247tc **U.S. National Institute of Health:** 243bl **X-Ray Astronomy Group, Leicester University:** 333tr **The Stock Market Photo Agency:** 39bc, 45cl, 47c, 351tl **Simon Warner:** 369br **C. James Webb:** 259tr

Oxford University Museum: back cover cl. **Science Photo Library:** Dr Jeremy Burgess back cover c; David Parker back cover crb. **Southampton Oceanography Centre:** front cover cb.

Every effort has been made to trace the copyright holders. DK Publishing apologises for any unintentional omissions and would be pleased, in any such cases, to add an acknowledgment in future editions.

Contributors to this series include:

Project Art Editors:

Simon Murrell, Paul Greenleaf

Additional design assistance:

Carla De Abreu, Anthea Forle, Laura Owen

Project Editors:

Philippa Colvin, Kirstie Hills, Peter Jones, Mukul Patel

Editor:

Des Reid

Additional editorial assistance:

Jo Evans, Caroline Hunt, Leah Kennedy, Jane Mason, Jane Sarlius, Roger Tritton

Senior Art Editor:

Tracey Hambleton-Miles

Senior Editor:

Louise Candlish

Picture Researchers:

Anna Lord, Sharon Southren,

Production:

Meryl Silbert, Stephen Stuart

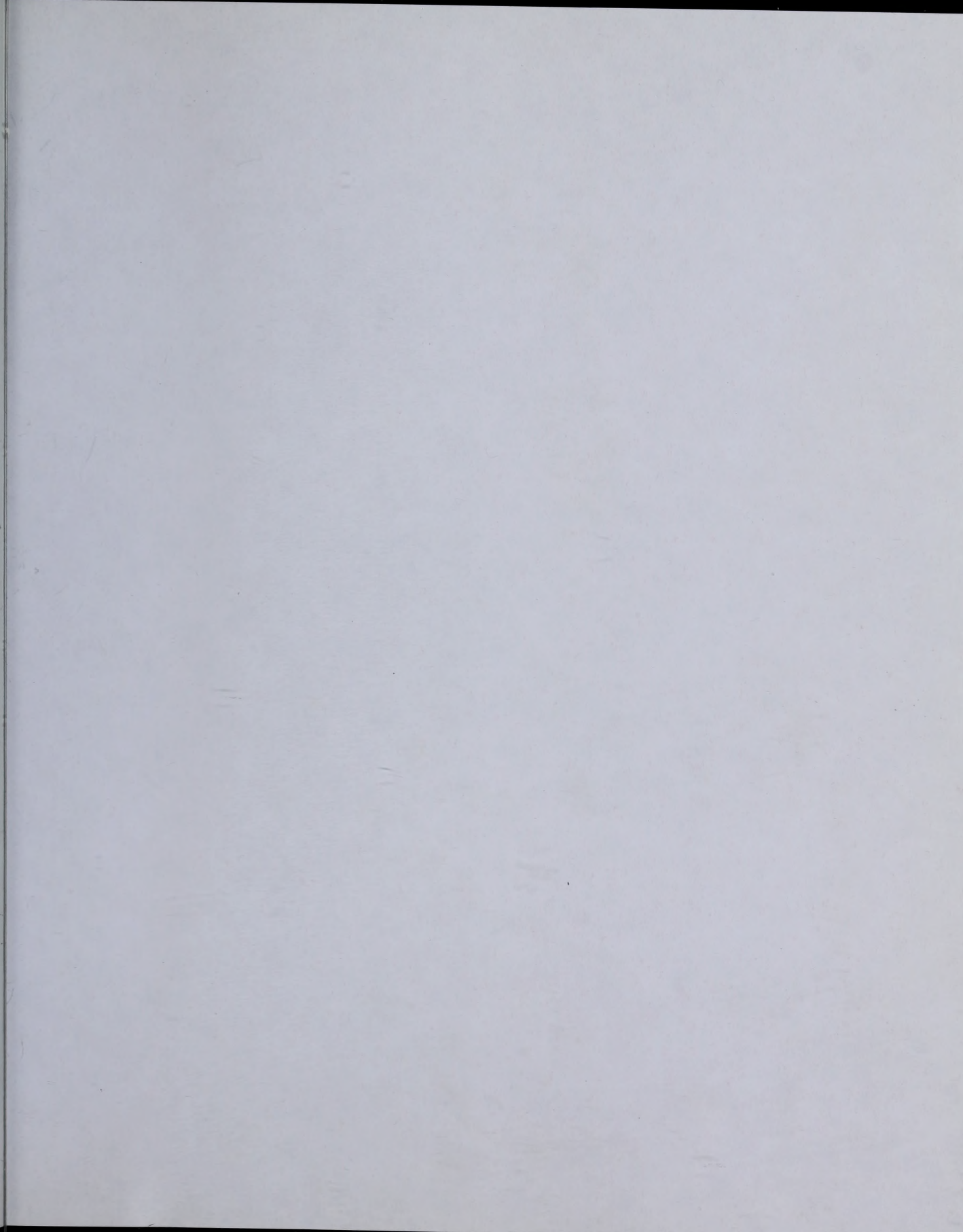

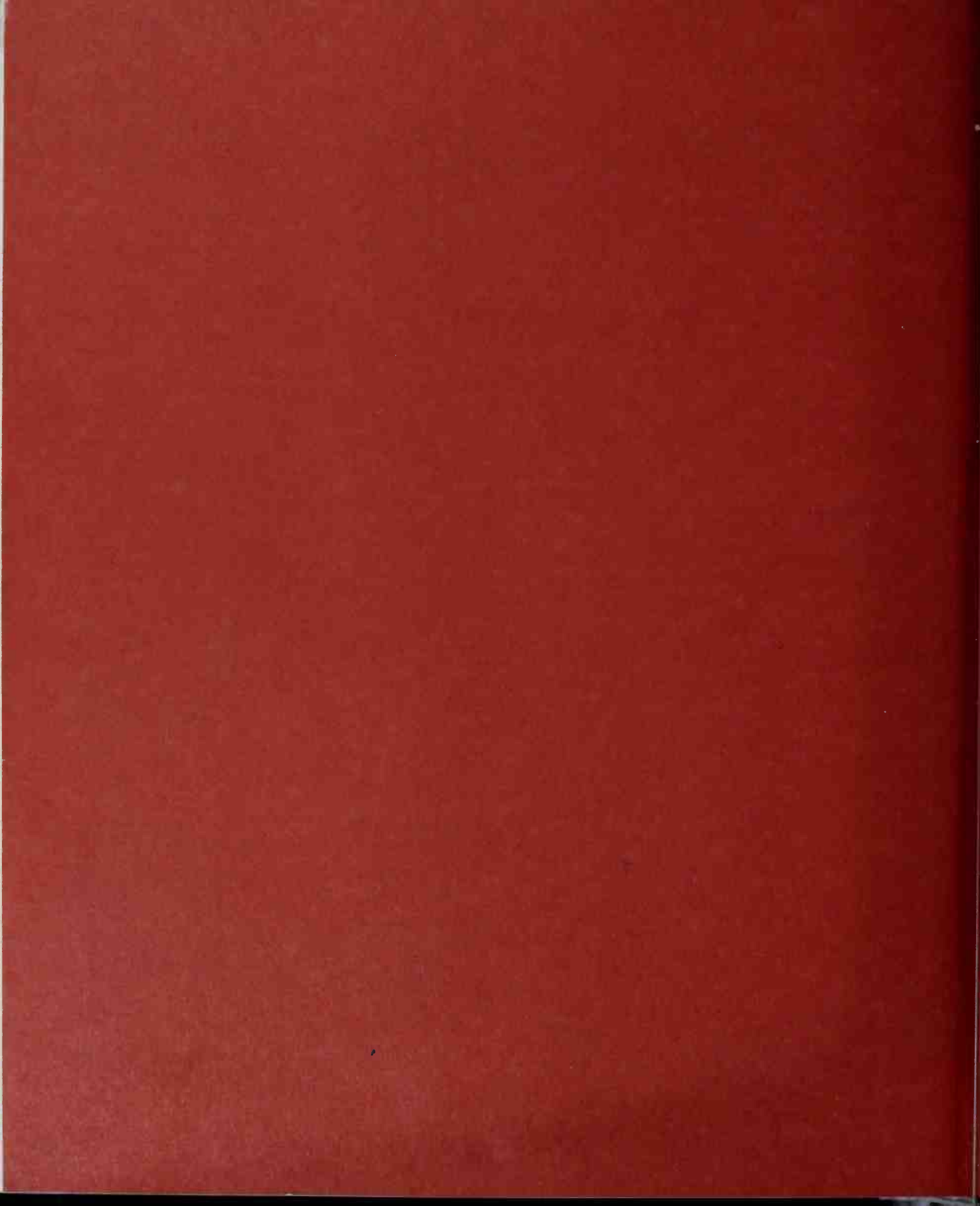

DK ULTIMATE VISUAL DICTIONARY OF SCIENCE

Subjects included in the
Ultimate Visual Dictionary of Science:

Physics • Chemistry • Life Sciences
Ecology • Human Anatomy
Medical Science • Earth Sciences
Astronomy • Astrophysics • Electronics
Computer Science • Mathematics



FERMENTATION

DK PUBLISHING, INC.
95 Madison Avenue
New York, NY 10016

Visit us on the World Wide Web at
<http://www.dk.com>

REFERENCE

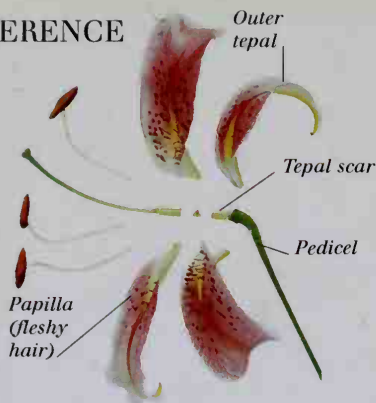

ULTIMATE VISUAL DICTIONARY OF SCIENCE



With over 15,000 terms and more than 1,600 color photographs and illustrations, this innovative scientific reference work is a must for everyone who has an interest in the world of science. The unique visual approach to the essential vocabulary of the main scientific disciplines makes the *Ultimate Visual Dictionary of Science* a first choice for home use and a necessity in the classroom.

From plant life to pollution, wormholes to black holes, and computers to cloning, the *Ultimate Visual Dictionary of Science* shows you what other books only tell you.



FOSSILIZED FROG

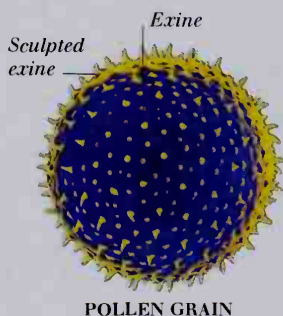

POLLEN GRAIN

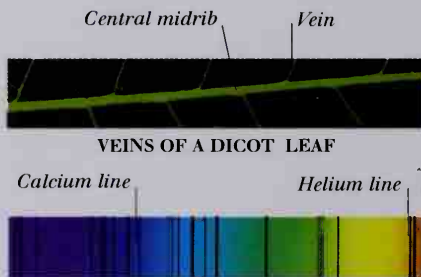

VEINS OF A DICOT LEAF

STELLAR SPECTRA



BONES OF THE BODY

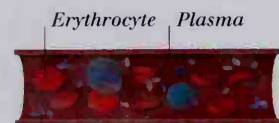

STRUCTURE OF BLOOD



SYRINGE

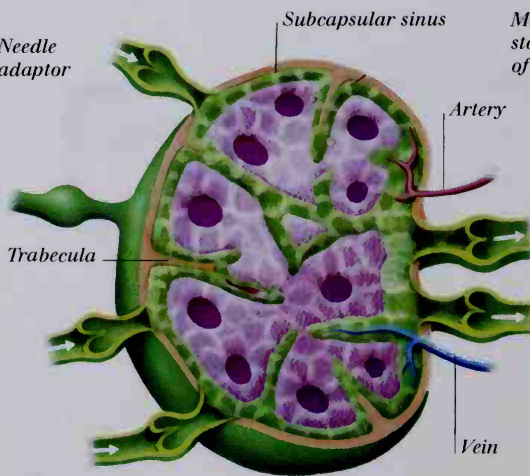

LYMPH NODE



STORING CHARGE

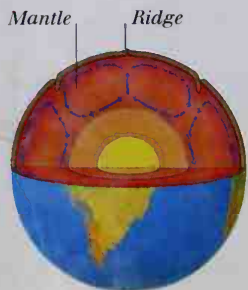

CONVECTION CURRENTS



DK PUBLISHING, INC.
www.dk.com

ISBN 0-7894-3512-8



9 780789 435125

90000

Printed in Italy